

MANUAL
OWNER'S

Instruction and recommendation booklet **IE**



INOXSTOR
200-300-500
V2
Storage tank



Dear Customer,

Our compliments for having chosen a top-quality Immergas product, able to assure well-being and safety for a long period of time. As an Immergas customer you can also count on a qualified after-sales service, prepared and updated to guarantee constant efficiency of your storage tank.

Read the following pages carefully: you will be able to draw useful suggestions regarding the correct use of the storage unit, the respect of which, will confirm your satisfaction for the Immergas product.

For any interventions or routine maintenance contact Authorised Centres: these have original spare parts and boast of specific preparation directly from the manufacturer.

General recommendations

All Immergas products are protected with suitable transport packaging.

The material must be stored in dry environments protected against bad weather.

The instruction book is an integral and essential part of the product and must be consigned to the new user also in the case of transfer or succession of ownership.

It must be stored with care and consulted carefully, as all of the warnings provide important safety indications for installation, use and maintenance stages.

This instructions manual provides technical information regarding installation of Immergas storage tank units. As for the other issues related to installation of the said storage tank units (e.g. safety in the work site, environment protection, injury prevention), it is necessary to comply with the provisions specified in the regulations in force and principles of good practice.

In compliance with legislation in force, the systems must be designed by qualified professionals, within the dimensional limits established by the Law. Installation and maintenance must be performed in compliance with the regulations in force, according to the manufacturer's instructions and by an authorised company, which has specific technical expertise in the system sector, as required by Law.

Improper installation or assembly of the Immergas appliance and/or components, accessories, kit and devices can cause unexpected problems to people, animals and objects. Read the instructions provided with the product carefully to ensure a proper installation.

Maintenance must be carried out by an authorised company. The Authorised After-sales Service represents a guarantee of qualification and professionalism.

The appliance must only be destined for the use for which it has been expressly declared. Any other use will be considered improper and therefore potentially dangerous.

If errors occur during installation, operation and maintenance, due to non compliance with technical laws in force, standards or instructions contained in this book (or however supplied by the manufacturer), the manufacturer is excluded from any contractual and extra-contractual liability for any damages and the appliance warranty is invalidated.

The manufacturer declines all liability due to printing or transcription errors, reserving the right to make any modifications to its technical and commercial documents without forewarning.

INDEX

1	Storage tank unit installation.....	5
1.1	Installation recommendations.....	5
1.2	Main dimensions.....	6
1.3	Hydraulic connection.....	7
1.4	System filling.....	7
1.5	Domestic hot water storage tank unit.....	7
1.6	Main components.....	8
1.7	Kit available on request.....	9
2	User and maintenance instructions	10
2.1	Cleaning and maintenance.....	10
2.2	Functioning.....	10
2.3	Emptying the storage tank unit.....	10
2.4	Case cleaning.....	10
2.5	Decommissioning.....	10
3	Control and maintenance.....	11
3.1	Functional diagrams.....	11
3.2	Yearly control and maintenance of the storage unit.....	13
4	Technical Data	14
4.1	Storage unit technical data.....	14
4.2	Product data sheet (in compliance with regulation 812/2013).....	15

1 STORAGE TANK UNIT INSTALLATION

1.1 INSTALLATION RECOMMENDATIONS.

The place of installation of the appliance and relative Immergas accessories must have suitable features (technical and structural) such to allow (always in safety, efficiency and comfortable conditions):

- installation (according to the provisions of the technical legislation and technical regulations);
- maintenance operations (including scheduled, periodic, routine and special maintenance);
- removal (to outdoors in the place for loading and transporting the appliances and components) as well as their eventual replacement with appliances and/or equivalent components.

Only professionally enabled companies are authorised to install Immergas appliances.

Installation must be carried out according to regulation standards, current legislation and in compliance with local technical regulations and the required technical procedures. Before installing the storage tank unit, ensure that it is delivered in perfect condition; if in doubt, contact the supplier immediately. Packing materials (staples, nails, plastic bags, polystyrene foam, etc.) constitute a hazard and must be kept out of the reach of children.

If the storage tank unit is installed inside or between cabinets, ensure there is sufficient space for normal servicing. It is advisable to leave an adequate gap between the storage tank casing and the sides of the cabinet.

A space of at least 650 mm is to be left in the upper part and 450 mm in the inspection and sacrificial anode connection areas.

In the event of a malfunction, fault or incorrect -operation, disable the storage tank unit and contact an authorised company (e.g. the Authorised Technical Assistance centre, which has specifically trained staff and original spare parts).

Do not attempt to modify or repair the appliance alone. Immergas is to comply with the conditions specified in the conventional warranty contract during the period of validity of the said warranty. Failure to comply with the above implies personal responsibility and invalidates the warranty.

- Installation regulations: previously check the features of the place of installation regarding clearance and total weight of the accumulation, if necessary placing a support surface under the storage tank in order to optimise distribution of the weight. These storage tanks have been designed only for floor installation; they must be used for the storage of domestic hot water for domestic and similar uses. They have not been designed for wall installation. Make sure that the volume and pre-charged pressure of the expansion tank of the secondary circuit are suitable for the system;

N.B.: It is mandatory to have a properly sized safety valve and expansion vessel to place on both hydraulic circuits.

Important: this storage unit is used to produce and store hot water; it must therefore be connected to a heating plant, to a domestic hot water distribution network and a water system, which are compatible with its performance and power. The materials used for the installation and connection must be completely compatible with the minimum features requested for solar use.

It must be installed in an environment where the temperature cannot fall below °C. It must not be exposed to atmospheric agents.

INSTALLER

USER

MAINTENANCE TECHNICIAN

TECHNICAL DATA

1.2 MAIN DIMENSIONS.

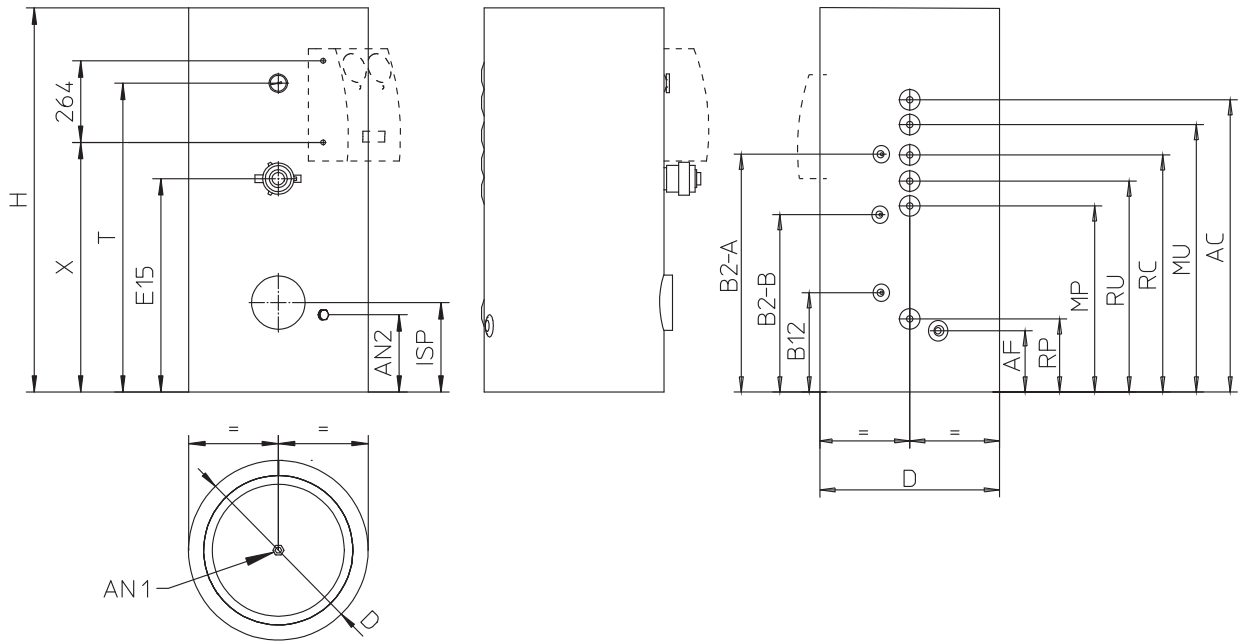

Key:

- D - Storage tank diameter
- H - Storage tank height
- AN - Sacrificial anode housing
- ISP - Inspection flange
- AF - Domestic cold water inlet
- RP - Return from solar panels
- MP - Solar panels flow
- RU - Return from storage tank
- RC - Pump (Optional)
- MU - Storage tank flow
- AC - Domestic hot water outlet
- B2-A - Domestic hot water probe
- B2-B - Heat pump probe (Only for 200 V2)
- B12 - Storage tank solar probe
- E15 - Storage tank integration resistance (optional)
- T - DHW thermometer
- X - Distance above ground to fix circulation unit

	INOXSTOR 200 V2 (mm)	Ø	INOXSTOR 300 V2 (mm)	Ø	INOXSTOR 500 V2 (mm)	Ø
D	Ø 620	--	Ø 620	--	Ø 810	--
H	1325	--	1715	--	1735	--
AN1		3/4"		3/4"		3/4"
AN2	259	3/4"	273	3/4"	289	3/4"
ISP	315	100x150	315	100x150	430	100x150
AF	222	3/4"	222	3/4"	215	1"
RP	265	3/4"	265	3/4"	305	1"
MP	675	3/4"	815	3/4"	860	1"
RU	765	3/4"	995	3/4"	960	1"
RC	860	3/4"	1130	3/4"	1200	3/4"
MU	970	3/4"	1345	3/4"	1310	1"
AC	1060	3/4"	1450	3/4"	1420	1"
B2-A	862	--	1237	--	1100	--
B2-B	640	--	--	--	--	--
B12	360	--	430	--	500	--
E15	715	1' 1/2	925	1' 1/2	910	1' 1/2
T	1035	--	1450	--	1350	--
X	805	--	1202	--	1180	--

1.3 HYDRAULIC CONNECTION.

Before making the connections, all of the system piping must be washed thoroughly to remove any residues that could compromise the good functioning of the storage tank. Water connections must be made in a rational way.

N.B.: while performing the connection, set up a drain fitting and an interception cock at the cold water inlet (AF) to facilitate maintenance operations. The storage tank safety valve outlet must be connected to a draining funnel. If this is not the case, the storage tank manufacturer declines any liability in the event of flooding if the drain valve cuts in.

Unused DHW side hydraulic connections are to be closed with hydraulic seal caps.

All connection fittings must be adequately insulated to minimise heat dispersion.

Insulated caps to be applied on unused fittings during installation are standard supplied.

Attention: to preserve the duration of the D.H.W. heat exchanger's efficiency features, we recommend the installation of a device to reduce the formation of lime scale in presence of water whose characteristics can lead to lime scale deposits.

1.4 SYSTEM FILLING.

On connection of the storage tank, fill the system. Filling is performed at low speed to ensure release of air bubbles in the water via the heating system vents.

The filling valve must be closed when the pointer on the boiler manometer indicates about 1.2 bar (see boiler instruction book).

1.5 DOMESTIC HOT WATER STORAGE TANK UNIT.

The storage tank unit must be connected to a boiler, solar panel system or heat pumps.

Storage tanks are insulated with high-performing insulating materials that can limit heat dispersion. The insulating material on Inoxstor 200 and 300 litre models is about 60 mm thick and about 80 mm thick on Inoxstor 500 litre model.

- Boiler protection: this storage tank is manufactured with a stainless steel casing and bottom, which guarantees a long life. The assembly concepts and welding (T.I.G.) are implemented to the minimum detail to ensure maximum reliability.
- Efficiency: the coiled heat exchange surface is sized to supply large quantities of hot water.
- The storage tank has two seats to include the sacrificial anode, which is supplied as standard to protect the inner part of the storage tank against corrosion; one is on the upper part and the other is on the side of the storage tank.

N.B.: annually check (e.g. the Authorised Technical Assistance centre) efficiency of the sacrificial anodes.

1.6 MAIN COMPONENTS.

INSTALLER

USER

MAINTENANCE TECHNICIAN

TECHNICAL DATA

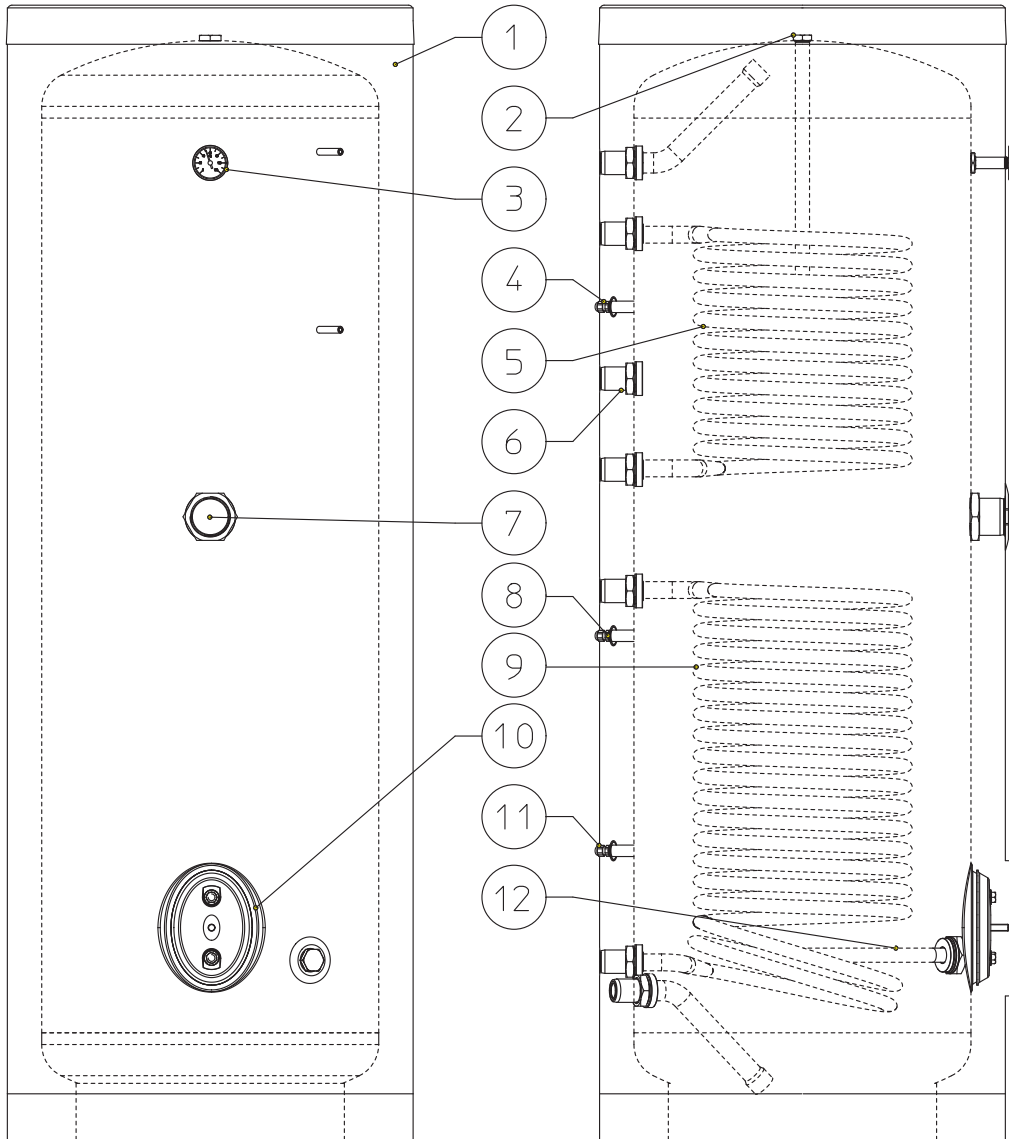

Key:

- | | |
|---|---|
| 1 - Insulating material | 7 - Storage tank integration resistance (optional) |
| 2 - Sacrificial anode L = 350 mm (L = 590 mm for Inoxstor 500) (optional seat for an electronic anode) | 8 - Heat pump probe (Only for 200 V2) |
| 3 - DHW thermometer | 9 - Solar panels coil |
| 4 - Domestic hot water probe | 10 - Inspection flange |
| 5 - Storage tank coil | 11 - Solar boiler probe |
| 6 - Recirculation fitting (Optional) | 12 - Sacrificial anode L = 350 mm (optional seat for an electronic anode) |

1.7 KIT AVAILABLE ON REQUEST.

- Pump kit (on request). The storage tank unit is prepared for application of the pump kit. Immergas supplies a series of fittings and attachments that allow connection between the storage tank unit and domestic hot water system. The pump kit attachment is also envisioned on the template.
- Solar panels kit (on request). The storage tank unit is set up to be coupled with solar panels. Immergas provides the various solar panel coupling kits on request.
- Storage tank integration resistance kit (on request). The storage tank unit is set up for application of an integration resistance to provide the anti-freeze function, which can be calibrated by a specific thermostat.
- Electronic anode kit. The storage tank is set up for the installation of the electronic anode. Direct current is made to circulate between the device and the tank to be protected via a special titanium anode screwed on and located inside storage tank itself. The capacity of the electronic anode for self learning and adjusting itself according to the actual conditions of the structure under protection make even the supply of the current dynamic and perfectly balanced with the requirements of the system to be protected.

The above kits are supplied complete with instructions for assembly and use.

INSTALLER

USER

MAINTENANCE TECHNICIAN

TECHNICAL DATA

2 USER AND MAINTENANCE INSTRUCTIONS

2.1 CLEANING AND MAINTENANCE.

Attention: to preserve integrity of the storage tank unit and keep the safety features, performance and reliability, which distinguish it, unchanged over time, you must at least execute maintenance operations on a yearly basis in compliance with what is stated in the relative point at “annual check and maintenance of the appliance”, in compliance with national, regional, or local standards in force. Annual maintenance is essential to validate the Immergas warranty. We recommend stipulating a yearly cleaning and maintenance contract with an authorised local firm.

2.2 FUNCTIONING.

This storage tank allows easy provisioning of water for domestic use and industrial use.

The storage tank is connected to the water distribution network via the cold water fitting and to the utilities via the hot water fitting. If a utility withdraws hot water, the cold water enters the tank where it is heated to the temperature set on the thermostat.

It is recommended to adjust the temperature between 60 and 65°C because this temperature guarantees the best performance of the storage tank unit and at the same time ensures:

- maximum hygiene
- maximum affordability
- delay in lime scale formation

The DHW in the storage tank is heated with the passage of CH/ solar water, which circulates inside the coils inside the storage tank unit itself.

In all cases the maximum temperature inside the storage tank unit must not exceed 99°C.

2.3 EMPTYING THE STORAGE TANK UNIT.

To drain the storage tank, use the special draining valve in the lower part of the storage tank.

Before draining, ensure that the DHW inlet valve is closed.

2.4 CASE CLEANING.

To clean the outer parts of the storage tank, just use a cloth dampened with product suitable for the purpose that can be found on the market. Abrasive, solvents, petrol and alcohol products are not recommended.

2.5 DECOMMISSIONING.

In the event of permanent shutdown of the storage tank, contact an authorised company for the relative operations, among other things making sure that water supply is disconnected.

At the end of its service life the appliance must not be disposed of like normal household waste nor abandoned in the environment, but must be removed by a professionally authorised company. Contact the manufacturer for disposal instructions.

3 CONTROL AND MAINTENANCE

3.1 FUNCTIONAL DIAGRAMS.

The following are two examples of the connection of the storage tank unit: one coupled with a solar panel central heating system (Fig. 3) and one coupled with Magis Pro 4-6-9 V2 (Fig. 4).

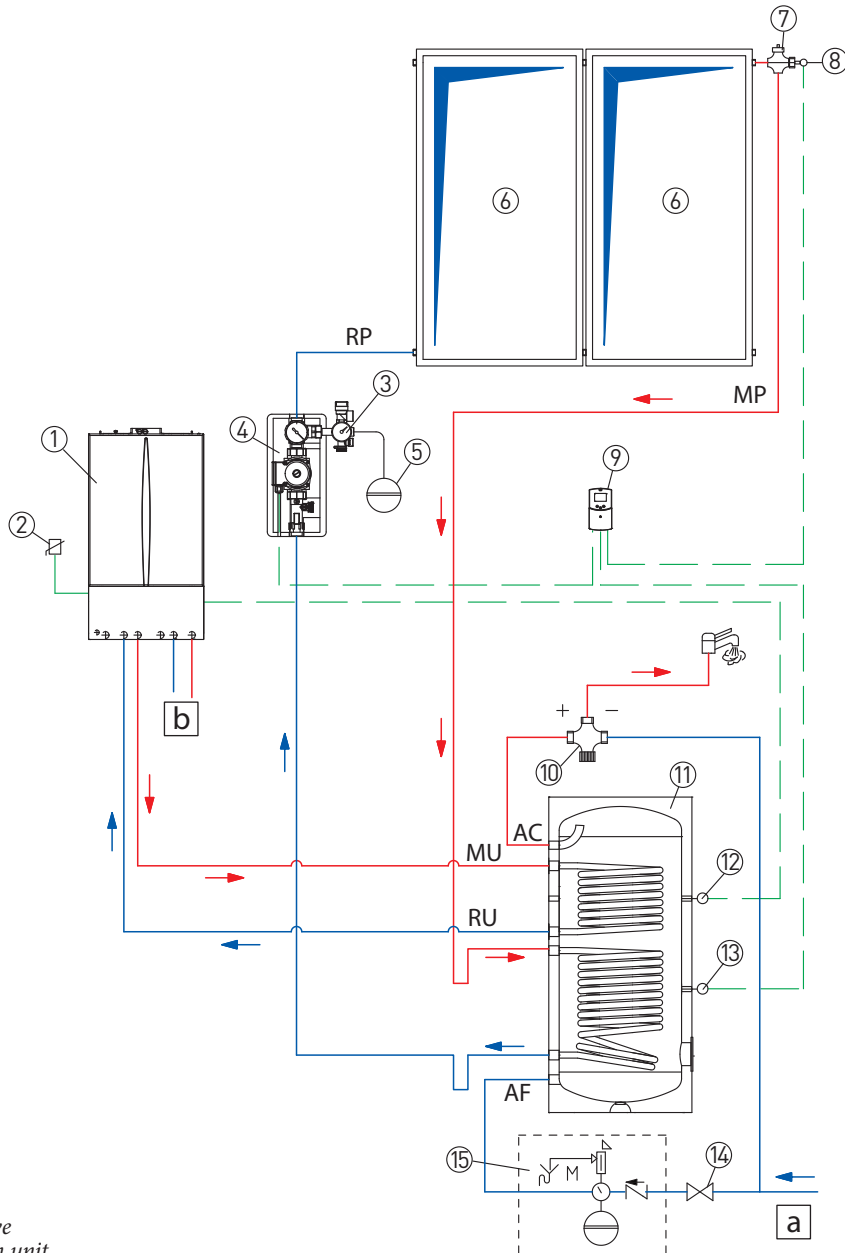

Key:

- 1 - Boiler
- 2 - External probe
- 3 - 6 bar safety valve
- 4 - Solar circulation unit
- 5 - Solar system expansion vessel
- 6 - Solar collectors
- 7 - System vent
- 8 - Probe unit
- 9 - Electronic control unit
- 10 - Mixing valve
- 11 - Inoxstor storage tank unit
- 12 - DHW probe fitting (NTC 10 k hom at 25°C supplied as per standard)
- 13 - Solar panel probe fitting
- 14 - Cold water inlet cock (Not supplied)
- 15 - DHW inlet safety unit (Not supplied)

a - Water-DHW network
b - To the heating system

AC - Domestic hot water outlet
AF - Domestic cold water inlet
MU - Storage tank unit flow
RU - Storage tank unit return
MP - Flow from solar panels
RP - Return to solar panels

INSTALLER

USER

MAINTENANCE TECHNICIAN

TECHNICAL DATA

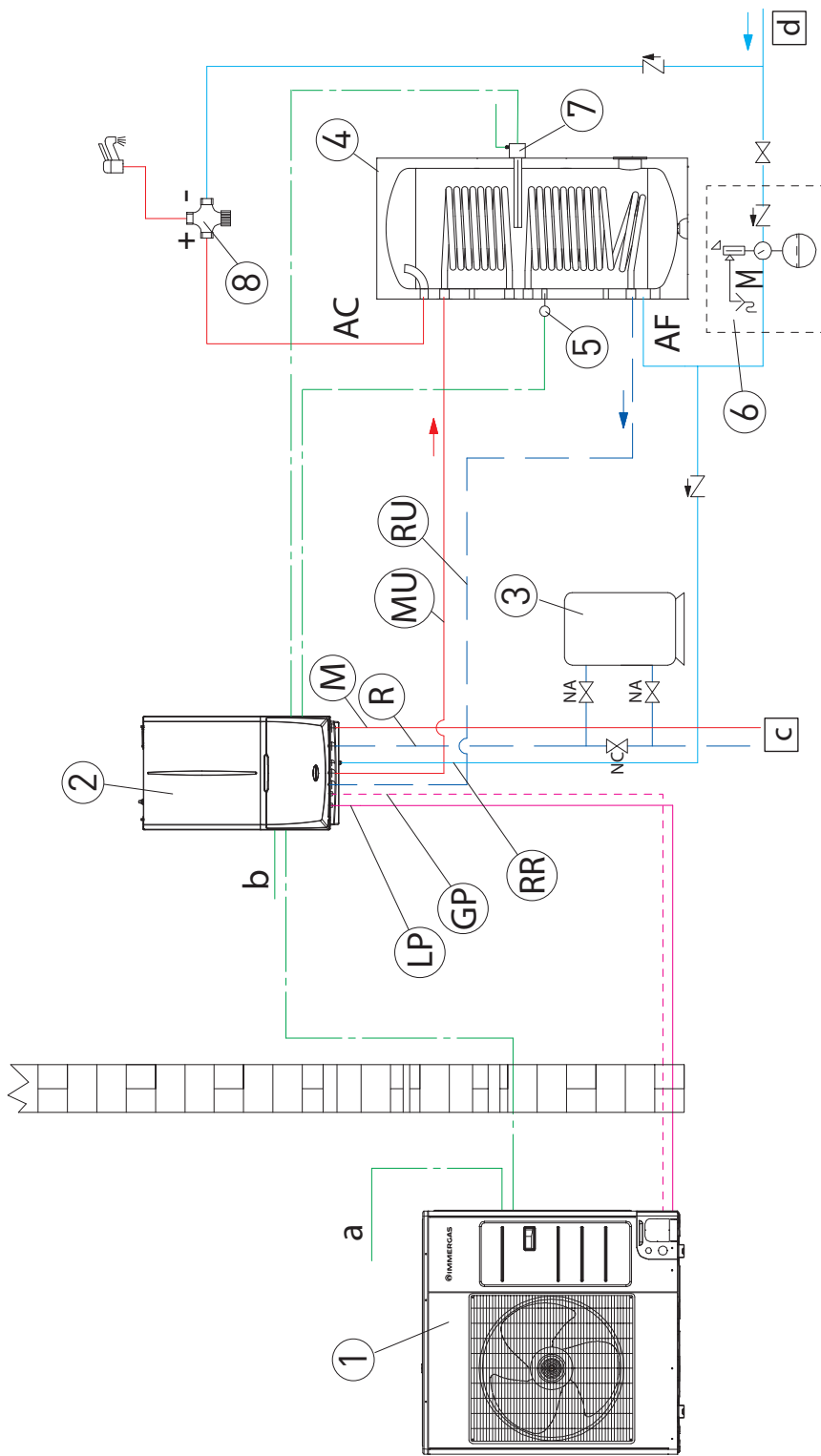

- Key:
- 1 - Audax Pro V2 outdoor condensing unit
 - 2 - Magis Pro V2 indoor unit
 - 3 - Thermal flywheel (to be sized)
 - 4 - Inoxstor storage tank unit
 - 5 - Storage tank unit probe
 - 6 - DHW inlet safety unit (Not supplied)
 - 7 - DHW integrative resistance
 - 8 - Mixing valve

- a - Audax Pro V2 outdoor condensing unit power supply
- b - Magis Pro V2 indoor unit power supply
- c - To the heating system
- d - Water-DHW network
- NC - Cock normally closed
- NA - Cock normally open
- AC - Domestic hot water outlet
- AF - Domestic cold water inlet
- MU - Storage tank unit flow
- RU - Storage tank unit return
- MP - Flow from solar panels
- RP - Return to solar panels
- RR - System filling
- M - System flow
- R - System return
- LP - Chiller line - liquid phase
- GP - Chiller line - gaseous phase

3.2 YEARLY CONTROL AND MAINTENANCE OF THE STORAGE UNIT.

The following checks and maintenance should be performed at least once a year.

- Visually check for water leaks or oxidation from/on connections;
- Check visually that the safety and control devices have not been tampered with and in particular:
 - adjustment probes;
 - expansion vessel;
 - domestic hot water side safety valve;
- Check integrity of the storage tank sacrificial anodes;
- In the case of particularly hard water, decalcification of the storage tank is recommended at least once a year. To perform this operation the tank must be emptied through the draining valve and then remove the flange in order to access the inside and use a plastic or wooden spatula to remove the most resistant deposits and then clean and rinse with a jet of water.
- During the cleaning phase pay particular attention not to damage the internal protection of the tank.
- On completion of the operation, re-mount the flange by applying the gasket (replace it with a new one if it is damaged), close the draining valve and fill the tank, checking that there are no leaks from the flange or the valve.

INSTALLER

USER

MAINTENANCE TECHNICIAN

TECHNICAL DATA

4 TECHNICAL DATA.

4.1 STORAGE UNIT TECHNICAL DATA.

		INOXSTOR 200	INOXSTOR 300	INOXSTOR 500
Hydraulic performances				
Storage tank unit capacity	l	202,6	279	480,3
Domestic hot water side maximum pressure	bar	8	8	8
DHW side maximum temperature	°C	99	99	99
Maximum coil pressure	bar	6	6	6
Central heating side maximum temperature	°C	90	90	90
Empty storage tank unit weight	kg	60,7	75,0	101,0
Full storage tank unit weight	kg	274,9	366,1	598,9
Heat dispersion	kW h / 24 h	1,95	2,18	2,41
Psbsol	W/K	1,81	2,02	2,23
Upper coil				
Exchange surface	m ²	0,72	0,8	1,23
Coil capacity	l	4,1	4,6	7,0
Exchange power	kW	32,0	32,0	32,0
Primary fluid flow rate	l/h	1630	1655	1845
Primary fluid T delta	°C	17	17	14,9
Useful reintegration power	kW	26,3	26,3	26,3
Lower coil				
Exchange surface	m ²	1,3	1,31	1,84
Coil capacity	l	7,5	7,5	10,6
Exchange power	kW	52,0	52,0	52,0
Primary fluid flow rate	l/h	2950	3080	3057
Primary fluid T delta	°C	15	14,5	14,6
Useful reintegration power	kW	34,3	34,3	34,3

INSTALLER

USER

MAINTENANCE TECHNICIAN

TECHNICAL DATA

4.2 PRODUCT DATA SHEET (IN COMPLIANCE WITH REGULATION 812/2013).

INOXSTOR 200 V2

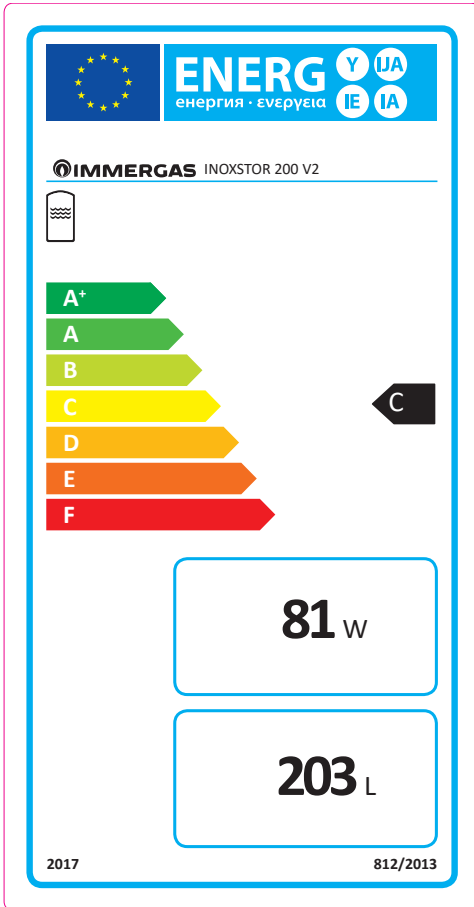

INOXSTOR 300 V2

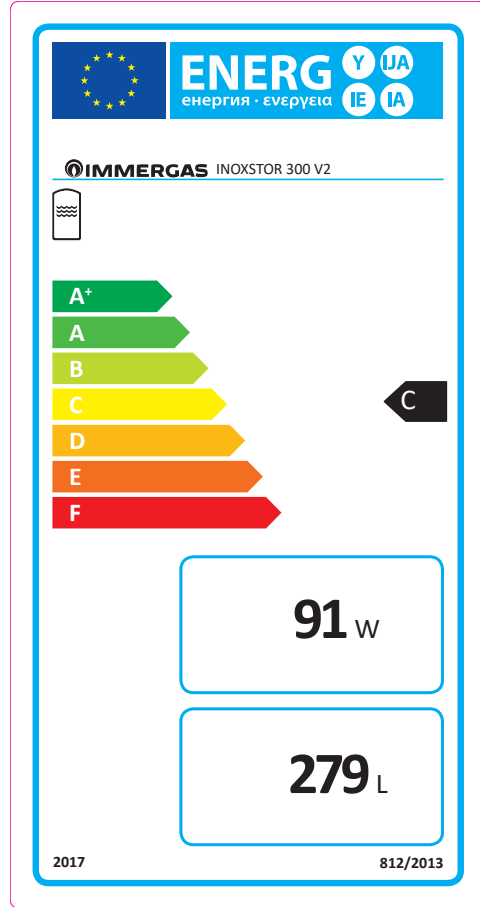

INOXSTOR 500 V2

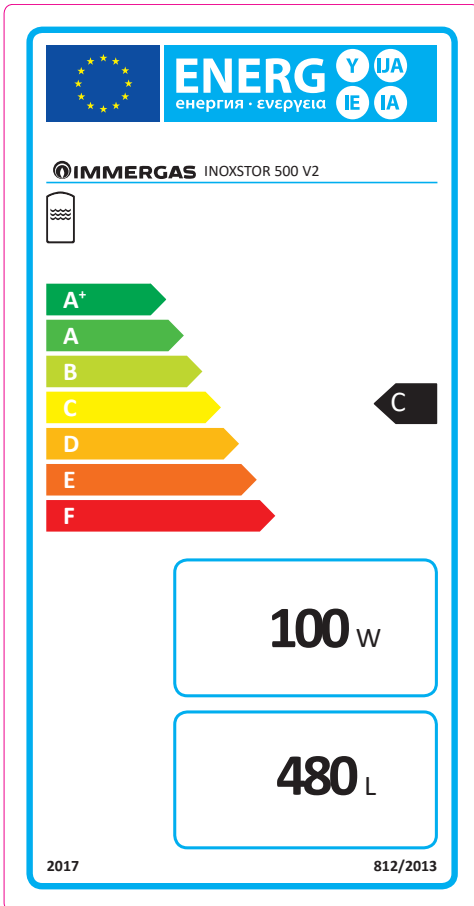

INSTALLER

USER

MAINTENANCE TECHNICIAN

TECHNICAL DATA



This instruction booklet
is made of ecological paper

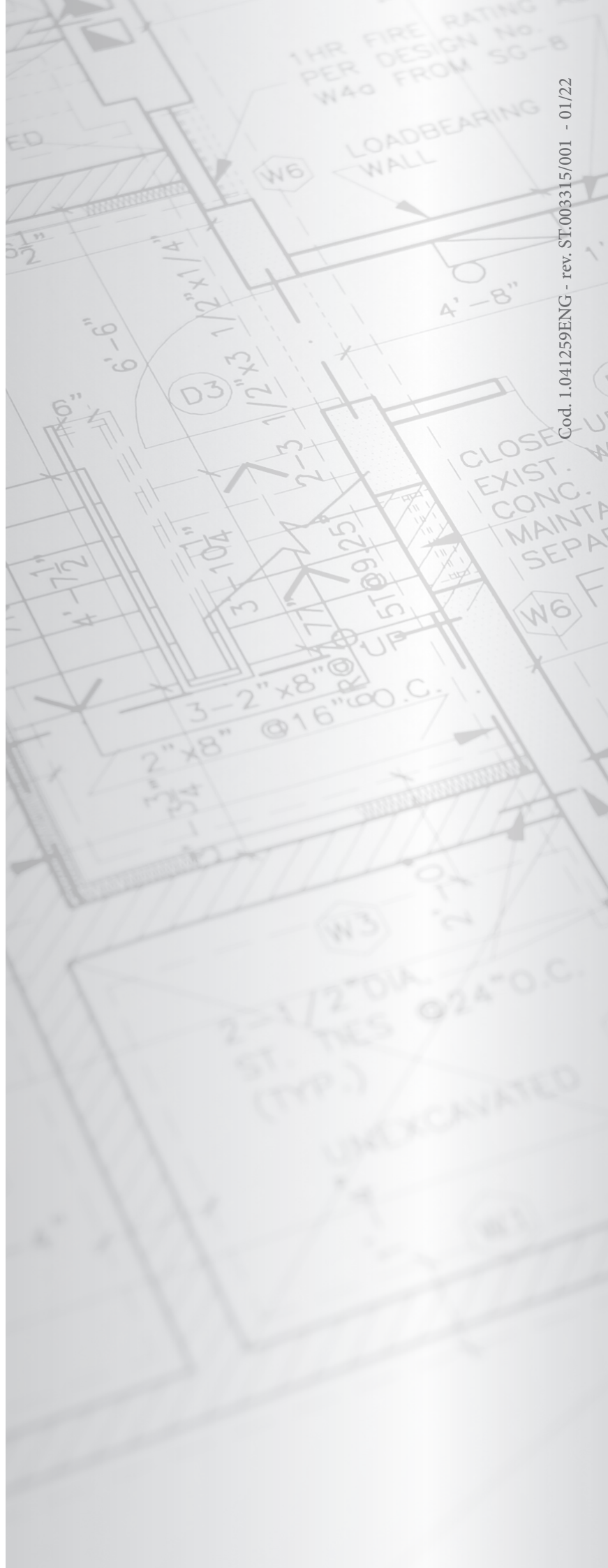

Cod. 1.041259ENG - rev. ST.003315/001 - 01/22



immergas.com

Immergas S.p.A.
42041 Brescello (RE) - Italy
Tel. 0522.689011
Fax 0522.680617