

# VICTRIX HYBRID VICTRIX HYBRID 32

**IE**

## Instructions and recommendations

Installer

User

Control Panel

Maintenance technician

Technical Data

\*1.046309ENG\*

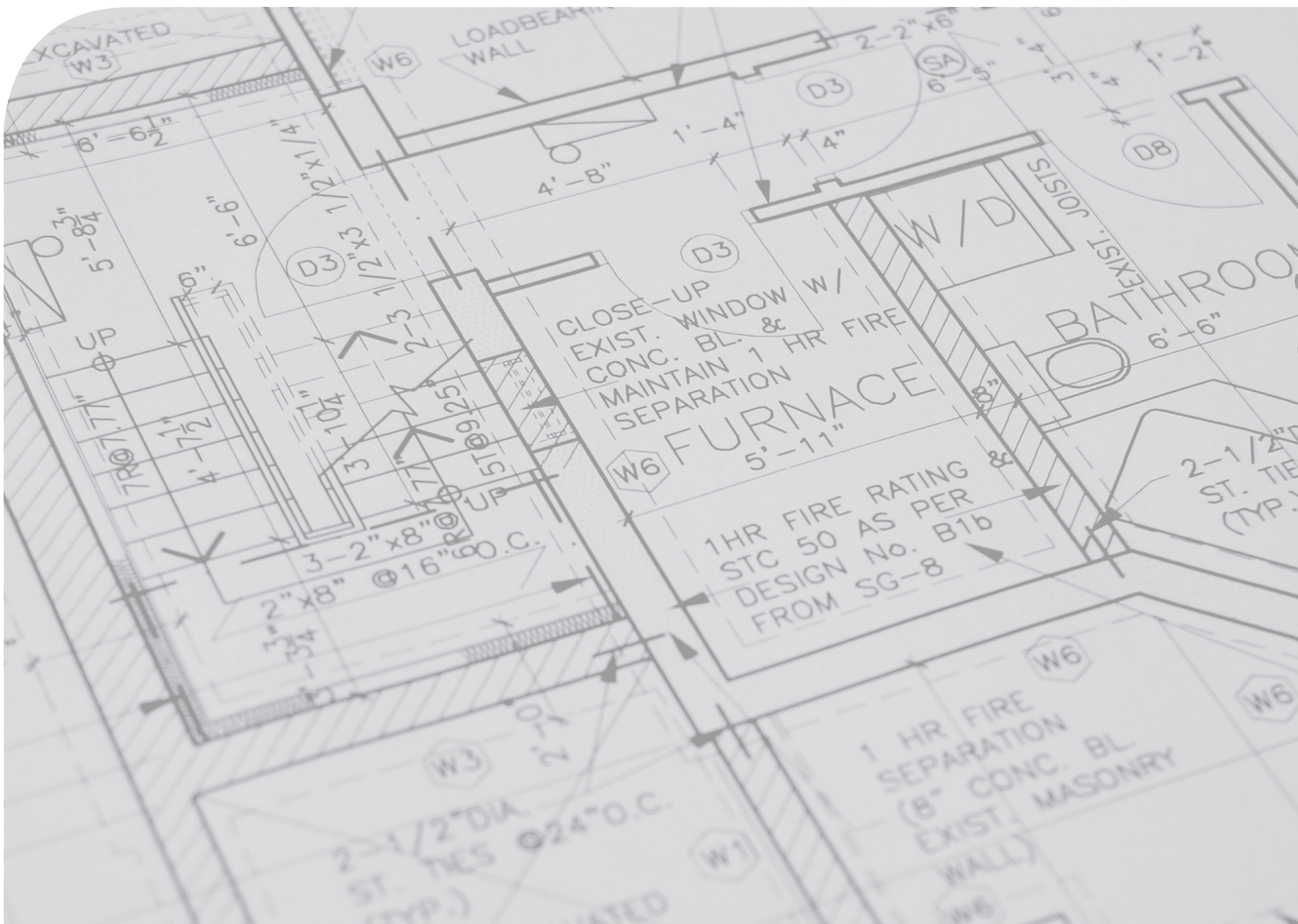

## INDEX

Dear Customer.....	5
General Recommendations.....	6
Safety symbols used.....	7
Personal protective equipment .....	7
<b>1 Unit installation .....</b>	<b>8</b>
1.1 Description of the product .....	8
1.2 Indoor unit installation recommendations .....	8
1.3 Installation warnings .....	14
1.4 Antifreeze protection .....	15
1.5 Data nameplate and installation information sticker .....	17
1.5.1 Data nameplate positioning.....	17
1.5.2 Key for data nameplate.....	18
1.5.3 Installation information sticker .....	18
1.6 Outdoor unit installation .....	19
1.7 Main dimensions .....	20
1.8 Minimum installation distances.....	21
1.9 Installation inside the recessed frame (Optional).....	22
1.10 Appliance connection unit.....	23
1.11 Gas connection.....	24
1.12 Hydraulic connection.....	25
1.13 Electrical connection.....	27
1.14 Control panel main dimensions .....	29
1.15 Control panel installation operations .....	30
1.16 External temperature probe.....	30
1.17 Remote controls and room chrono-thermostats (Optional) .....	30
1.18 230 VAC configurable outlet .....	31
1.19 General examples of types of installation of flue systems .....	32
1.20 Immergas flue systems.....	33
1.21 Equivalent lengths of "Green Range" flue system components.....	35
1.22 Maximum flue length .....	41
1.23 Outdoor installation or in a partially protected area .....	44
1.24 Internal installation using a recessed frame with direct air intake .....	46
1.25 Concentric horizontal kit installation .....	47
1.26 Concentric vertical kit installation .....	51
1.27 Installation of vertical terminals Ø 80.....	56
1.28 Separator kit installation .....	57
1.29 Adaptor kit installation C <sub>9</sub> .....	60
1.30 Ducting of flues or technical slots .....	62
1.31 Configuration for C <sub>6</sub> flue installation.....	63
1.32 Configuration type B, open chamber and fan assisted for indoors .....	64
1.33 Flue exhaust to flue/chimney.....	64
1.34 Flues, chimneys and chimney caps. ....	65
1.35 Water treatment plant filling.....	66
1.36 System filling .....	67
1.37 Filling the condensate drain trap.....	67
1.38 Gas system start-up.....	67
1.39 Appliance start-up (Ignition).....	68
1.40 UPM4 circulation pump.....	69
1.41 Kits available on request .....	71
1.42 Main components .....	72
<b>2 Instructions for use and maintenance .....</b>	<b>73</b>



2.1	General recommendations .....	73
2.2	Cleaning and maintenance .....	75
2.3	Appliance switch-off.....	76
2.4	Restore central heating system pressure .....	76
2.5	Draining the system.....	76
2.6	Emptying the D.H.W. circuit.....	77
2.7	Antifreeze protection .....	77
2.8	Prolonged inactivity .....	77
2.9	Cleaning the case.....	77
2.10	Permanent shutdown.....	77
<b>3</b>	<b>Control panel.....</b>	<b>78</b>
3.1	Control panel.....	78
3.2	Operation overview .....	78
3.3	Comfort / Economy / Manual operation .....	79
3.4	Operation with external probe .....	79
3.5	Clock and programs.....	80
3.6	P.C.B. programming.....	82
3.7	Indoor Unit Control Panel .....	88
3.8	System use .....	89
3.9	Indoor unit P.C.B. programming.....	90
3.10	Password-protected special functions.....	96
3.11	Automatic vent function (dl).....	97
3.12	Flue installation (FU).....	97
3.13	Maintenance function (MA).....	97
3.14	Screed heater.....	98
3.15	Chimney sweep .....	99
3.16	Information menu.....	100
3.17	Fault and anomaly signals .....	101
<b>4</b>	<b>Instructions for maintenance and initial check.....</b>	<b>108</b>
4.1	General recommendations .....	108
4.2	Initial check .....	109
4.3	Yearly appliance check and maintenance .....	110
4.4	Hydraulic diagram.....	114
4.5	Wiring diagram.....	115
4.6	Troubleshooting.....	116
4.7	Converting the appliance to other types of gas.....	117
4.8	Fan speed calibration .....	118
4.9	CO <sub>2</sub> /O <sub>2</sub> regulation .....	119
4.10	Checks following conversion to another type of gas .....	119
4.11	Solar panels coupling .....	120
4.12	Pump anti-block.....	120
4.13	Three-way anti-block.....	120
4.14	Radiator antifreeze .....	120
4.15	Ambient antifreeze .....	120
4.16	Operating logic .....	121
4.17	Casing removal.....	122
<b>5</b>	<b>Technical data.....</b>	<b>126</b>
5.1	Variable heat output .....	126
5.2	Combustion parameters .....	128
5.3	Indoor unit technical data table .....	129
5.4	Outdoor unit technical data table .....	130
5.5	Product fiche (in compliance with Regulation 811/2013).....	132



5.6 Parameters for filling in the package fiche .....136



## Dear Customer

*Congratulations for having chosen a top-quality Immergas product, able to assure well-being and safety for a long period of time. As an Immergas customer you can also count on a Qualified Authorised After-Sales Technical Assistance Centre, prepared and updated to guarantee the constant efficiency of your products. Read the following pages carefully: you will be able to draw useful tips on the proper use of the device, compliance with which will confirm your satisfaction with the Immergas product.*

**Thermal systems must undergo periodic maintenance and scheduled checks of the energy efficiency in compliance with national, regional or local provisions in force.**

*For assistance and routine maintenance, contact Authorised Technical Service Centres: they have original spare parts and are specifically trained directly by the manufacturer.*

---

---

The company **IMMERGAS S.p.A.**, with registered office in via Cisa Ligure 95 42041 Brescello (RE), declares that the design, manufacturing and after-sales assistance processes comply with the requirements of standard **UNIEN ISO 9001:2015**.

For further details on the product CE marking, request a copy of the Declaration of Conformity from the manufacturer, specifying the appliance model and the language of the country.

The manufacturer declines all liability due to printing or transcription errors, reserving the right to make any modifications to its technical and commercial documents without forewarning.





## GENERAL RECOMMENDATIONS

This book contains important information for the:

**Installer** (sections 1, 3 and 5) to install the AUDAX.DK4 outdoor unit, please refer to the relevant instruction manual;

**User** (section 2 and section 3);

**Maintenance technician** (section 3, section 4 and section 5).

- The user must carefully read the instructions in the specific section (sec. 2 and sect. 3).
- The user must limit operations on the appliance only to those explicitly allowed in the specific section.
- The appliance must be installed by qualified and professionally trained personnel.
- The instruction booklet is an integral and essential part of the product and must be given to the new user in the case of transfer or succession of ownership.
- It must be stored with care and consulted carefully, as all of the warnings provide important safety indications for installation, use and maintenance stages.
- In compliance with the legislation in force, the systems must be designed by qualified professionals, within the dimensional limits established by the Law. Installation and maintenance must be performed in compliance with the regulations in force, according to the manufacturer's instructions and by professionally qualified staff, meaning staff with specific technical skills in the plant sector, as provided for by Law.
- Improper installation or assembly of the Immergas device and/or components, accessories, kits and devices can cause unexpected problems for people, animals and objects. Read the instructions provided with the product carefully to ensure proper installation.
- This instructions manual provides technical information for installing Immergas products. As for the other issues related to the installation of products (e.g. safety at the workplace, environmental protection, accident prevention), it is necessary to comply with the provisions of the standards in force and the principles of good practice.
- All Immergas products are protected with suitable transport packaging.
- The material must be stored in a dry place protected from the weather.
- Damaged products must not be installed.
- Maintenance must be carried out by skilled technical staff. For example, the Authorised Service Centre that represents a guarantee of qualifications and professionalism.
- The appliance must only be destined for the use for which it has been expressly declared. Any other use will be considered improper and therefore potentially dangerous.
- If errors occur during installation, operation and maintenance, due to non-compliance with technical laws in force, standards or instructions contained in this booklet (or however supplied by the manufacturer), the manufacturer is excluded from any contractual and extra-contractual liability for any damages and the device warranty is invalidated.
- In the event of malfunctions, faults or incorrect operation, turn the appliance off and contact an authorised company (e.g. the Authorised Technical Assistance Centre, which has specifically trained staff and original spare parts). Do not attempt to modify or repair the appliance alone.



## SAFETY SYMBOLS USED



### GENERIC HAZARD

Strictly follow all of the indications next to the pictogram. Failure to follow the indications can generate hazard situations resulting in possible harm to the health of the operator and user in general, and/or property damage.



### ELECTRICAL HAZARD

Strictly follow all of the indications next to the pictogram. The symbol indicates the appliance's electrical components or, in this manual, identifies actions that can cause an electrical hazard.



### WARNING FOR INSTALLER

Read the instruction booklet carefully before installing the product.



### LOW FLAMMABILITY MATERIAL

The symbol indicates that the appliance contains low flammability material.



### WARNINGS

Strictly follow all of the indications next to the pictogram. Failure to follow the indications can generate hazard situations resulting in possible minor injuries to the health of both the operator and the user in general, and/or slight material damage.



### ATTENTION

Read and understand the instructions of the appliance before carrying out any operation, carefully following the instructions given. Failure to observe the instructions may result in malfunction of the unit.



### INFORMATION

Indicates useful tips or additional information.



### DANGER OF HOT SURFACES

The symbol indicates the appliance's very hot components that can cause burns.



### EARTH TERMINAL CONNECTION

The symbol identifies the appliance's earth terminal connection point.



### DISPOSAL WARNING

**The user must not dispose of the appliance at the end of its service life as municipal waste, but send it to appropriate collection centres.**

## PERSONAL PROTECTIVE EQUIPMENT



### SAFETY GLOVES



### EYE PROTECTION



### SAFETY FOOTWEAR



# 1 UNIT INSTALLATION

## 1.1 DESCRIPTION OF THE PRODUCT

Victrix Hybrid is a hybrid heat pump consisting of:

- Victrix 24HY indoor unit;
- Audax.DK4 outdoor unit;
- Victrix Hybrid control panel (supplied in the accessories group of the indoor unit).

Victrix Hybrid 32 is a hybrid heat pump consisting of:

- Victrix 32HY indoor unit;
- Audax.DK4 outdoor unit;
- Victrix Hybrid control panel (supplied in the accessories group of the indoor unit).

The Victrix Hybrid heat pump was designed only for central heating and production of domestic hot water for domestic use and similar purposes.

For its normal operation, the indoor unit must be combined with the Audax.DK4 outdoor unit and the Victrix Hybrid control panel; therefore, it is necessary to comply with all prescriptions regarding safety and use of the control panel, indoor unit and outdoor unit.

## 1.2 INDOOR UNIT INSTALLATION RECOMMENDATIONS



**Operators who install and service the appliance must wear the personal protective equipment required by applicable law.**



This unit is designed for wall-mounted installation only.



The place of installation of the appliance and relative Immergas accessories must have suitable features (technical and structural), such as to allow for (always in safe, efficient and comfortable conditions):

- installation (according to the provisions of technical legislation and technical regulations);
- maintenance operations (including scheduled, periodic, routine and special maintenance);
- removal (to outdoors in the place for loading and transporting the appliances and components) as well as the eventual replacement of those with appliances and/or equivalent components.



The wall surface must be smooth, without any protrusions or recesses enabling access to the rear part. They are not designed to be installed on plinths or floors (Fig. 1).

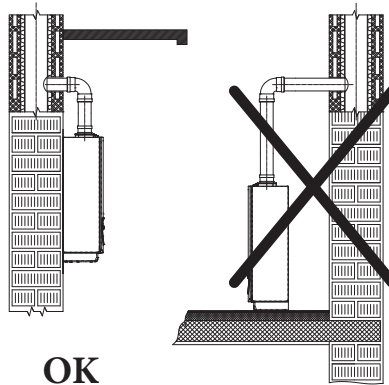





By varying the type of installation the classification of the appliance and precisely:

- **Type B<sub>23</sub> or B<sub>53</sub>** appliance if installed using the relevant terminals for air intake directly from the room in which the appliance has been installed.
- **Type C appliance** if installed using concentric pipes or other types of pipes envisioned for the sealed chamber appliance for intake of air and expulsion of flue gas.



The equipment classification is shown in the illustrations of the various installation solutions on the following pages.



Only professionally enabled companies are authorised to install Immergas gas appliances.



Installation must be carried out according to regulation standards, current legislation and in compliance with local technical regulations and the required technical procedures.



It is forbidden to install appliances removed from other systems.

The manufacturer declines all liability in the event of damage caused by appliances removed from other systems or for any non-conformities with such equipment.



Check the environmental operating conditions of all parts relevant to installation, referring to the values shown in the technical data table in this booklet.



**Installation of the appliance when powered by LPG or propane air must comply with the rules regarding gases with a greater density than air (remember, as an example, that it is prohibited to install plants powered with the above-mentioned gas in rooms where the floor is at a lower quota than the country level).**



If installing a kit or servicing the appliance, always empty the system's circuit first so as not to compromise the appliance's electrical safety (Parag. 2.5).

Always disconnect the appliance from voltage and, depending on the type of operation, decrease the pressure and/or bring it to zero in the gas and DHW circuits.



Before installing the appliance, ensure that it is delivered in perfect condition; if in doubt, contact the supplier immediately.

Packing materials (staples, nails, plastic bags, polystyrene foam, etc.) constitute a hazard and must be kept out of the reach of children.

If the appliance is installed inside or between cabinets, ensure sufficient space for routine servicing; for minimum installation distances, see Fig. 7.



**It is just as important that the intake grids and exhaust terminals are not obstructed.**



**It is recommended to check that no flue gas recirculation is found in the air sample points (0.5% maximum permitted CO<sub>2</sub>).**



The minimum distance for exhaust pipes from flammable materials must be at least 25 cm.



Keep all combustible material away from the appliance (paper, rags, plastic, polystyrene, etc.).





Split exhaust ducts must not pass through walls of combustible material.



Do not place household appliances underneath the appliance as they could be damaged if the safety valve intervenes, if the drain trap is blocked, or if there are leaks from the hydraulic connections; otherwise, the manufacturer cannot be held responsible for any damage caused to the household appliances.



For the aforementioned reasons, we recommend not placing furnishings, furniture, etc. under the appliance.



In the event of malfunctions, faults or incorrect operation, turn the appliance off and contact an authorised company (e.g. the Authorised Technical Assistance Centre, which has specifically trained staff and original spare parts). Do not attempt to modify or repair the appliance alone.



Any modification to the appliance that is not explicitly indicated in this section of the booklet is forbidden.



## Installation standards



This appliance can be installed outdoors in a partially protected area.  
By partially protected area, we mean one in which the unit is not directly exposed to the elements (rain, snow, hail, etc.).



**Installation of gas appliances, flue exhaust pipes and combustion air intake pipes is forbidden in places with a fire risk (for example: garages, closed parking stalls), and in potentially dangerous places.**



**Do not install on the vertical projection of hobs (for appliances up to 35 kW).**



**Do not install in places/rooms that constitute public areas of apartment buildings, internal stairways or other escape routes (e.g. floor landings, entrance halls, etc.).**



**These appliances, if not adequately isolated, are not suitable for installation on walls of combustible material.**



**Installation is also forbidden in places/rooms that constitute public areas of apartment buildings such as cellars, entrance halls, attics, lofts, etc., unless otherwise provided for by local regulations in force.**



Installing the wall recessed frame kit must guarantee the Indoor Unit stable, efficient support.

The recessed frame kit ensures appropriate support only if installed correctly (according to the rules of good practice), following the instructions on its instructions leaflet.

For safety reasons against any leaks it is necessary to plaster the housing compartment of the Indoor Unit in the brick wall.

The recessed frame for the boiler is not a supporting structure and must not replace the wall removed. It is necessary to position the boiler inside the wall.

The plugs (standard supply) that come with the appliance are only to be used to fix the latter to the wall; they only ensure adequate support if inserted correctly (according to technical standards) in walls made of solid or semi-hollow brick or block. In the case of walls made from hollow brick or block, partitions with limited static properties, or in any case walls other than those indicated, a static test must be carried out to ensure adequate mount. Appliances must be installed in such a way as to avoid knocks or tampering.



**Wall mounting of the appliance must guarantee stable and efficient support for the generator.**



These appliances are used to heat water to below boiling temperature in atmospheric pressure.



They must be connected to a central heating system and domestic hot water circuit suited to their performance and capacity.



**Risk of damage due to corrosion caused by unsuitable combustion air and environment.**

Spray, solvents, chlorine-based detergents, paints, glue, ammonium compounds, powders and similar cause product and flue duct corrosion.



Check that combustion air power supply is free from chlorine, sulphur, powders, etc.



Make sure that no chemical substances are stored in the place of installation.



If you want to install the product in beauty salons, paint workshops, carpenter's shop, cleaning companies or similar, choose a separate installation area that ensures combustion air supply that is free from chemical substances.



Make sure the combustion air is not fed through chimneys that were previously used with boilers or other central heating appliances powered by liquid or solid fuels. In fact, these may cause an accumulation of soot in the chimney

**Risk of material damage after using sprays and liquids to search for leaks**

Leak sprays and liquids clog the reference hole P1. Ref. (Fig. 79) of the gas valve, damaging it irreparably. During installation and maintenance, do not use spray or liquids on the gas valve (electric connections side).

**Filling the condensate drain trap**

**When the appliance is switched on for the first time, combustion products come out of the condensate drain. After a few minutes of operation, check that combustion flue gases are no longer coming out of the condensate drain; this means that the drain trap has filled to a correct condensate height that the flue gases cannot pass through.**

**Special provisions for appliances installed in B<sub>23</sub> or B<sub>53</sub> configuration.**

**Type B open chamber indoor units must not be installed in places where commercial, artisan or industrial activities take place, which use products that may develop volatile vapours or substances (e.g. acid vapours, glues, paints, solvents, combustibles, etc.), as well as dusts (e.g. dust deriving from the working of wood, coal fines, cement, etc.), which may be harmful for the components of the appliance and jeopardise operation.**



**In configuration B<sub>23</sub> and B<sub>53</sub>, unless local regulations are in force, the appliances must not be installed in bedrooms, bathrooms, toilets or studios; they must neither be installed in rooms containing solid fuel heat generators nor in rooms communicating with said rooms.**



For appliances for domestic use (up to 35 kW) in B<sub>23</sub> and B<sub>53</sub> configuration, the installation rooms must be permanently ventilated, in compliance with the local regulations in force (at least 6 cm<sup>2</sup> for each kW of heat input installed, except in the case of the presence of electromechanical extractor fans or other devices that can depressurise the installation room).



Install the appliances in B<sub>23</sub> and B<sub>53</sub> configuration in non-residential premises and which are permanently ventilated.



Failure to comply with the above implies personal responsibility and invalidates the warranty.



### 1.3 INSTALLATION WARNINGS

INSTALLER



**Victrix Hybrid must be installed in strict compliance with the hydraulic and electrical requirements set out in Parag. 1.12 and 1.13.**

#### Basic requirements.



The minimum water content required within the system is 20 litres; otherwise, it will be necessary to install an inertial storage tank (optional).



For proper system operation, make sure that the minimum flow rate in operating conditions never drops below 500 l/h.



When the circulation within each room central heating loop is controlled by remotely operated valves, it is important to guarantee the minimum water content (20 litres), even if all the valves are closed.



When the circulation within each or certain room central heating loops is controlled by remotely operated valves, it is important to guarantee the minimum flow rate, even if all the valves are closed. It is necessary to have a loop that is always open on the system (by-pass or non-intercepted zone), to allow some functions such as, for example, the antifreeze function.



Make sure that the expansion vessel present in the indoor unit is sufficient for the hydraulic circuit; otherwise use the optional vessel.



If you are using one or more booster pumps it is essential to install a hydraulic separator (not supplied by Immergas) downstream of the Indoor Unit.  
The minimum required 20l must be guaranteed between the indoor unit and the hydraulic separator.



Make sure to connect the flow from heat pump (MHT) of the outdoor unit to the system return (R) of the indoor unit.



In the case of kit installation or maintenance of the Victrix Hybrid, always empty the system and DHW circuits first, in order to avoid compromising its electrical safety (see Parag. 2.5 and 2.6).

USER

CONTROL PANEL

MAINTENANCE TECHNICIAN

#### Only for Audax.DK4.



**The appliance operates with R32 refrigerant gas.**

**This gas is ODOURLESS.**

**Pay the utmost attention**

**Strictly follow the instruction handbook of the Outdoor Unit before installation and any type of operation on the chiller circuit.**

TECHNICAL DATA



**R32 refrigerant gas belongs to the low flammability refrigerant category: class A2L according to standard ISO 817. It guarantees high performance with low environmental impact. The new gas reduces the potential environmental impact by one third compared to R410A, having less effect on global warming (GWP 675).**



## 1.4 ANTIFREEZE PROTECTION

Frost can damage the system; therefore, freezing of the components must be prevented by performing the following actions after determining the minimum outdoor installation temperature and the location of the indoor unit (indoors or outdoors):

External minimum temperature	Indoor unit (UI)		Outdoor unit (OU)	
	UE	UI	UE	UI
-5°C	IU antifreeze kit	NO	IU antifreeze kit	NO
	OU condensate antifreeze kit	NO	OU condensate antifreeze kit	NO
	Glycol	NO	Glycol	NO
	OU antifreeze protection valve	YES	OU antifreeze protection valve	YES
	OU antifreeze protection	3	OU antifreeze protection	3
-15°C	IU antifreeze kit	NO	IU antifreeze kit	YES
	OU condensate antifreeze kit	YES	OU condensate antifreeze kit	YES
	Glycol	NO	Glycol	YES
	OU antifreeze protection valve	YES	OU antifreeze protection valve	NO
	OU antifreeze protection	3	OU antifreeze protection	2
-25°C	IU antifreeze kit	NO	<b>Antifreeze protection not guaranteed</b>	
	OU condensate antifreeze kit	YES		
	Glycol	YES		
	OU antifreeze protection valve	NO		
	OU antifreeze protection	2		

IU = Indoor unit  
OU = Outdoor unit



**IU antifreeze kit (optional):** protects the DHW circuit and condensate drain of the indoor unit from -5°C to -15°C.



**OU condensate antifreeze kit (optional):** protects the condensate drain of the outdoor unit from -5°C to -15°C.



**Glycol:** protects the circuit of the outdoor unit from frost from -15°C to -25°C and protects the central heating circuit of the indoor unit (if mounted outdoors) from -5°C to -15°C.



**If glycol is present, the antifreeze protection valve supplied as an accessory must not be fitted.**



The antifreeze liquid must not be harmful to one's health.

**Freeze protection of the outdoor and indoor units by means of the antifreeze function (including -15°C protection of the DHW circuit with resistance kit) is ensured only if:**

- The units and the control panel are correctly connected to the power supply circuit, the gas supply circuit and constantly supplied and connected to each other;
- The indoor unit is not in "off" mode;
- The indoor and outdoor units are not malfunctioning (Par. 3.17);
- The antifreeze unit and/or kit essential components are not faulty.



If the previous conditions are not followed (for example in case of an interruption of the electrical power supply), these antifreeze functions are not able to guarantee the protection of the outdoor unit against freezing.



- The materials used for the central heating circuit of Immergas units resist ethylene and glycol based antifreeze liquids (if the mixtures are prepared perfectly). Adding glycol lowers the freezing point of water.
- The required concentration depends on the lowest expected outside temperature, in any case not below -25°C, and whether or not the risk of bursting or freezing of the system is to be prevented. More glycol is required to prevent the system from freezing. Add glycol according to the indications of the table below.
- An aqueous solution must be made with potential pollution class of water in compliance with the local standards in force.
- For life and possible disposal, follow the supplier's instructions.



Protection from risk of bursting: glycol prevents the pipes from bursting, but it does NOT prevent freezing of the liquid they contain for outdoor temperatures below -15°C.



Protection from risk of freezing : glycol prevents freezing of the liquid contained inside the pipes for outdoor temperatures down to -15°C.

Lowest expected external temperature	Prevention from risk of bursting	Prevention from risk of freezing
-5°C	10%	15%
-10°C	15%	25%
-15°C	20%	35%
-20°C	25%	—
-25°C	30%	—



- The required concentration may vary according to the type of glycol. ALWAYS compare the requirements of the table above with the specifications provided by the glycol manufacturer. If necessary, comply with the requirements provided by the glycol manufacturer.
- The concentration of additional glycol must NEVER exceed 35%.
- If the liquid in the system should freeze, the pump will NOT be able to start. Remember that the risk of freezing of the liquid in the system is present if even if the bursting risk of the system is prevented.

If the glycol concentration is sufficient to protect the unit in all outdoor temperature conditions, set "Level 1" in the parameter "O.U. anti-freeze protect.". Whereas if the protection is only partial, set "Level 2" in the same parameter (par. 2.7).



The presence of glycol may trigger corrosion of the system, since glycol without inhibitors becomes acid under the influence of oxygen. The process is accelerated by the presence of copper and high temperatures. Non-inhibited acid glycol affects metallic surfaces and creates galvanic corrosion cells that cause serious damage to the system.

Therefore, it is important that:

Freezing of components must therefore be prevented by performing the following actions:

- A proper water treatment is performed by a specialised technician;
- A glycol with corrosion inhibitors able to contrast the acids formed by glycol oxidation is selected;
- Automotive glycol is not used, since its corrosion inhibitor has a limited duration and contains silicates which may obstruct or clog the system;
- Galvanised pipes are NOT used in systems with glycol, since their presence may cause some components in the inhibitor to be corroded by glycol;
- Ensure proper frost protection of the connection pipes between the indoor unit and the outdoor unit.



In the event of failure to use antifreeze fluid, damage resulting from power failure and failure to comply with the preceding paragraphs shall be excluded for the effectiveness of the warranty.





## 1.5 DATA NAMEPLATE AND INSTALLATION INFORMATION STICKER

### 1.5.1 Data nameplate positioning

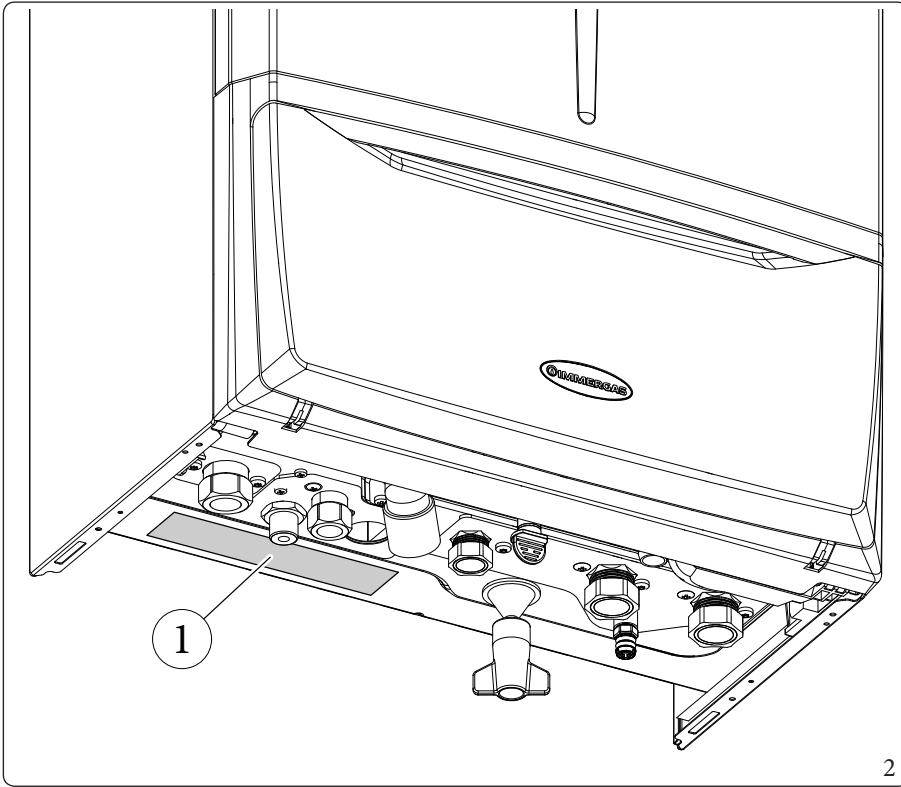

Key (Fig. 2):

1 - Data plate

INSTALLER

USER

CONTROL PANEL

MAINTENANCE TECHNICIAN

TECHNICAL DATA





## 1.6 OUTDOOR UNIT INSTALLATION

Refer to the Audax.DK4 instruction manual for installation of the outdoor unit.

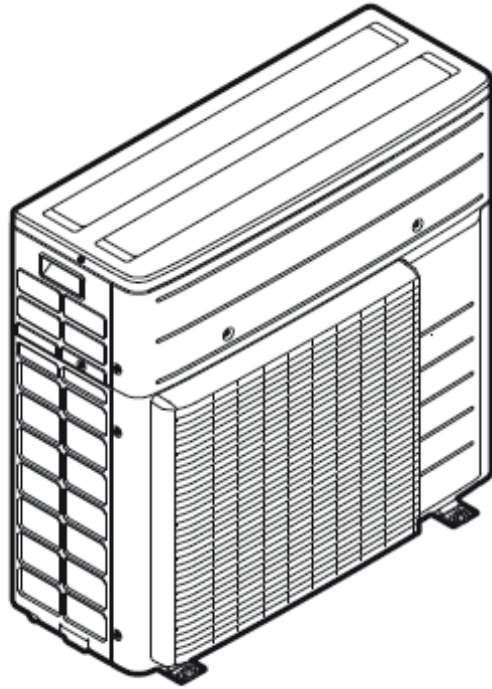

5

INSTALLER

USER

CONTROL PANEL

MAINTENANCE TECHNICIAN

TECHNICAL DATA



### 1.7 MAIN DIMENSIONS

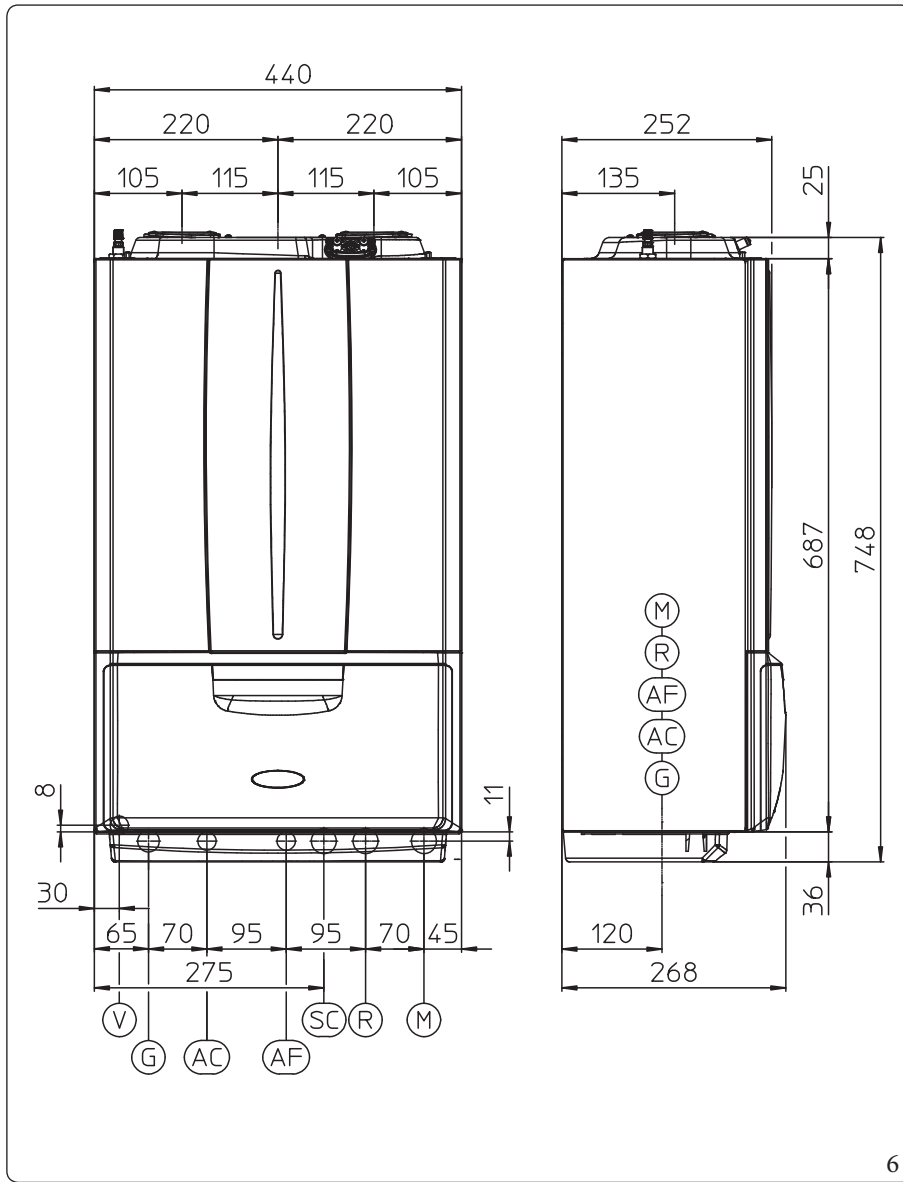

Key (Fig. 6):

- V - Electrical connection
- G - Gas supply
- AC - Domestic hot water outlet
- AF - Domestic hot water inlet
- SC - Condensate drain (minimum internal diameter Ø 13 mm)
- M - System flow
- R - System return

Height (mm)	Width (mm)		Depth (mm)	
748	440		268	
CONNECTIONS				
GAS	DOMESTIC HOT WATER		SYSTEM	
G	AC	AF	R	M
3/4"	1/2"	1/2"	3/4"	3/4"

## 1.8 MINIMUM INSTALLATION DISTANCES

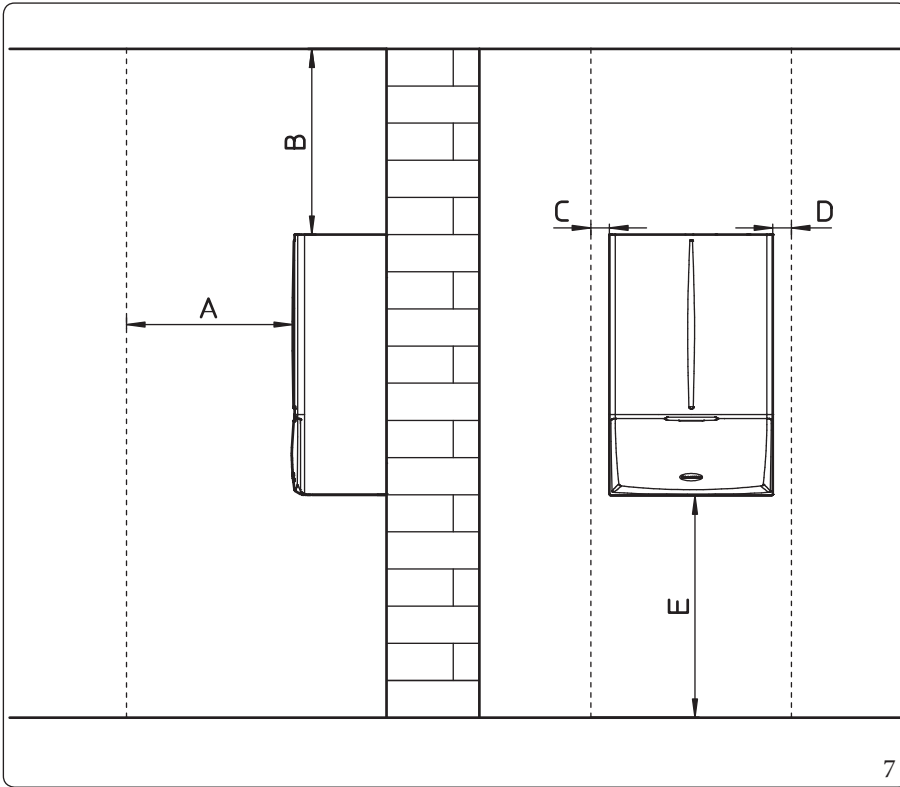

Key (Fig. 7):

- A - 450 mm
- B - 350 mm
- C - 30 mm
- D - 30 mm
- E - 350 mm

INSTALLER

USER

CONTROL PANEL

MAINTENANCE TECHNICIAN

TECHNICAL DATA



## 1.9 INSTALLATION INSIDE THE RECESSED FRAME (OPTIONAL)

The appliance is designed to be installed in the Immergas recessed frame (supplied as optional) only coupled with the enlarged door kit. To install proceed as follows:

- To be installed in the Immergas recessed frame (supplied as optional) only coupled with the enlarged door kit.
- Install the bracket (2) inside the recessed frame fixing it with the screws (3) in the pre-drilled holes (Fig. 8).
- Hang the appliance (4) on the bracket (2) (Fig. 9).
- Block the boiler (4) by mounting the brackets (5) and fixing them with their screws (6) (Fig.10).

The brackets (5) used to centre the appliance on the frame and hold it in place stop against the frame (1) so do not require fixing to the frame itself.

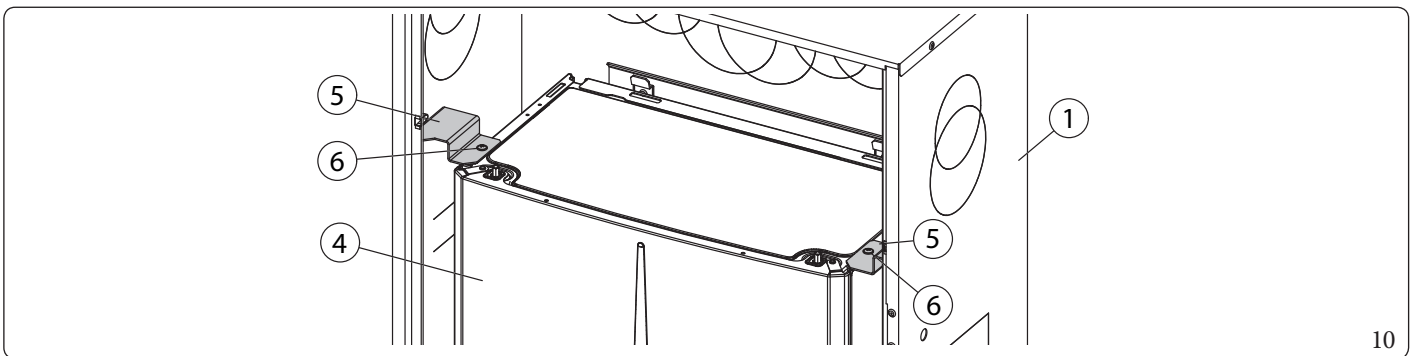
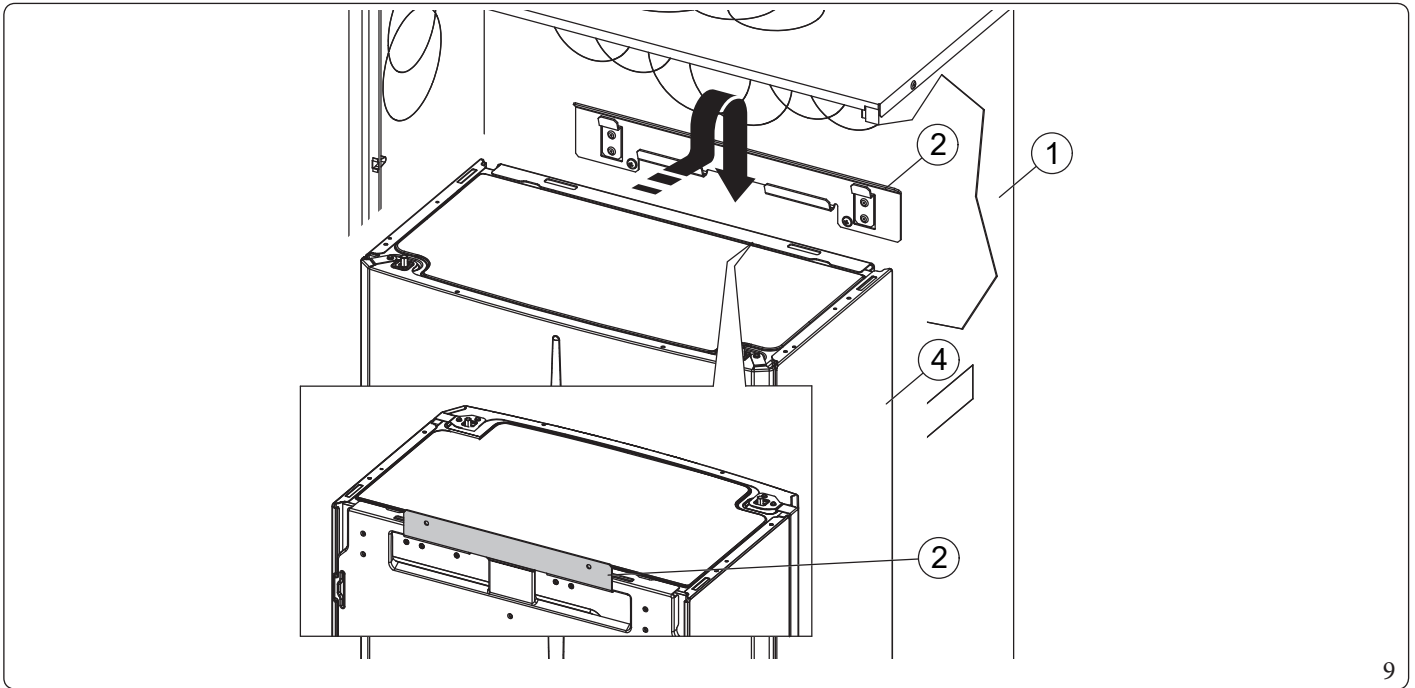
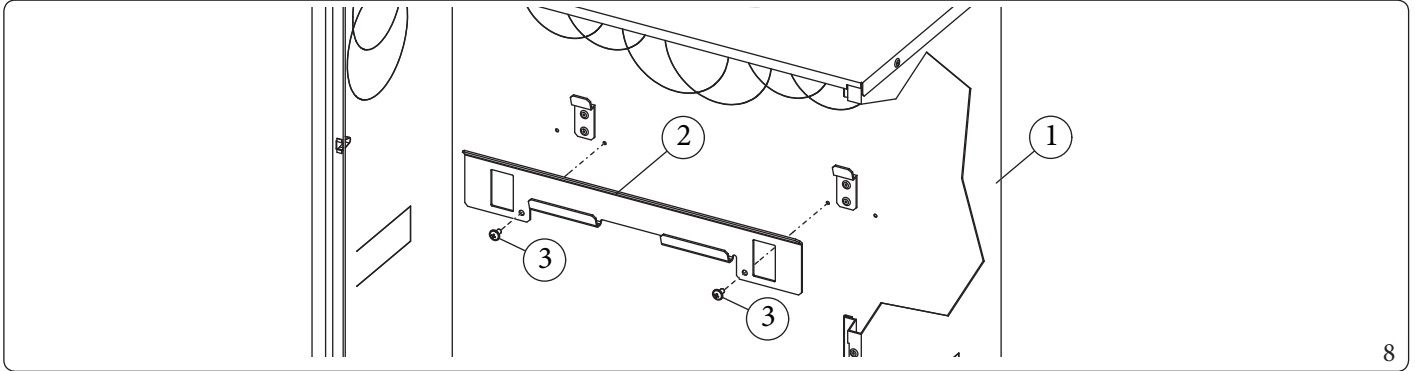

## 1.10 APPLIANCE CONNECTION UNIT

The connection unit is supplied as standard.

Make the hydraulic and gas system connection of the indoor unit in accordance with the layout (Fig. 11) and according to the type of installation to be carried out.

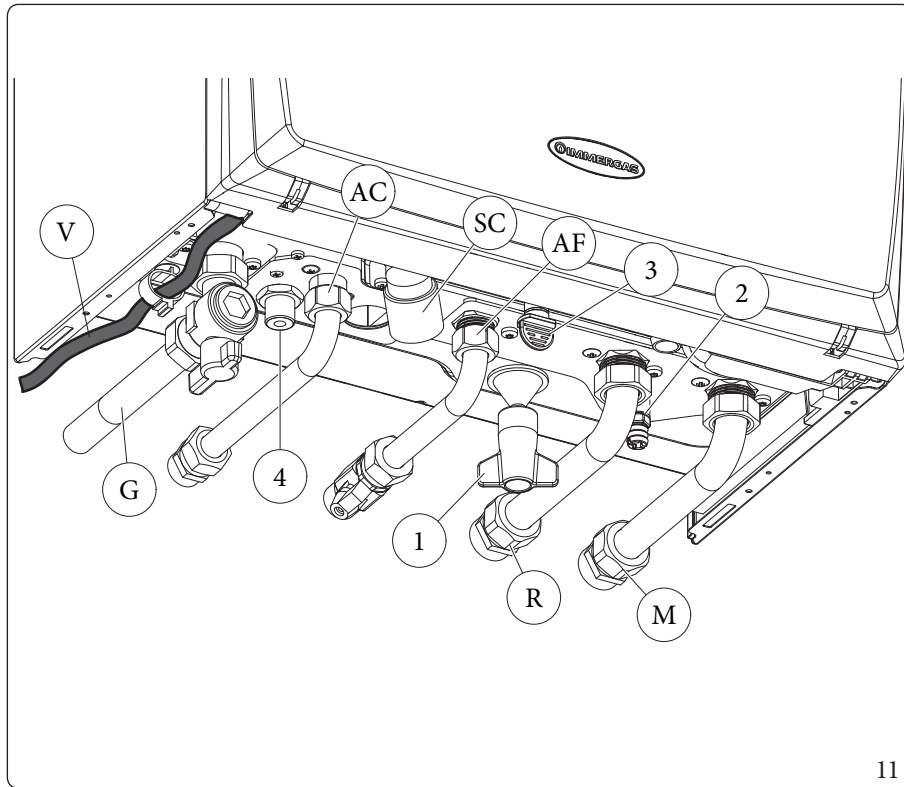

Key (Fig. 11):

- V - Electrical connection
- G - Gas supply
- AC - Domestic hot water outlet
- SC - Condensate drain (minimum internal diameter Ø 13 mm)
- M - G 3/4" System flow
- R - System return
- 1 - System filling valve
- 2 - System draining valve
- 3 - 3 bar safety valve drain fitting signal
- 4 - Air vent valve drain

INSTALLER

USER

CONTROL PANEL

MAINTENANCE TECHNICIAN

TECHNICAL DATA



## 1.11 GAS CONNECTION

Our appliances are built to work with natural gas (G20), LPG and mixtures of methane and hydrogen at 20% in volume (20%H2NG), referred to the gas distributed in the network. Power supply pipes must be the same as or larger than the appliance fitting.



Before connecting the gas line, carefully clean inside all the fuel feed system pipes to remove any residue that could impair appliance efficiency.

Also make sure the gas corresponds to that for which the appliance is prepared (see appliance data nameplate).

If different, the boiler must be converted for operation with the other type of gas (see converting appliance for other gas types).



**It is also important to check the dynamic pressure of the mains (methane or LPG) used to supply the boiler, which must comply with EN 437 and its attachment, as insufficient levels may reduce generator output and cause discomfort to the user. Static/dynamic network pressures higher than those required for regular operation may cause serious damage to the appliance control elements; in this case shut the gas line off.**

**Do not operate the device.**

**Have the device checked by experienced personnel.**



**According to the local regulation in force, make sure that a gas isolation valve is installed upstream of each connection between the appliance and the gas system. This valve, if supplied by the appliance's manufacturer, can be directly connected to the appliance (i.e. downstream from the pipes connecting the system to the appliance), according to the manufacturer's instructions.**

**The Immergas connection unit, supplied as an optional kit, also includes the gas isolation valve, whose installation instructions are provided in the kit.**

**In any case, make sure the gas isolation valve is connected properly.**

The gas supply pipe must be suitably dimensioned according to current regulations in order to guarantee correct gas flow rate to the burner even in conditions of maximum generator output and to guarantee appliance efficiency (technical specifications).

The coupling system must conform to standards in force (EN 1775).



The appliance is designed to operate with fuel gas free from impurities; otherwise it is advisable to fit special filters upstream of the appliance to restore the purity of the fuel.

### Storage tanks (in case of supply from LPG depot).

- New LPG storage tanks may contain residual inert gases (nitrogen) that degrade the mixture delivered to the appliance causing functioning anomalies.
- Due to the composition of the LPG mixture, layering of the mixture components may occur during the period of storage in the tanks. This can cause a variation in the calorific value of the mixture delivered to the appliance, with subsequent change in its performance.



## 1.12 HYDRAULIC CONNECTION



In order not to void the primary heat exchanger warranty, before making the device connections, carefully clean the heating system (pipes, radiators, etc.) with special pickling or descaling products to remove any deposits that could compromise correct device operation.

The current technical standards in force prescribes the washing and treatment of the water in the heating and water system, in order to protect the system and the appliance from deposits (e.g. scale), slurry or other hazardous deposits.

In order not to void the heat exchanger warranty, you are required to comply with what has been prescribed in (Par. 1.35).

### Indoor Unit hydraulic connection.

Hydraulic connections must be made in a rational way using the couplings on the appliance template.



The manufacturer declines all liability in the event of damage caused by the installation of an automatic filling system.

In order to meet the system requirements established by EN 1717 in terms of pollution of drinking water, we recommend installing the IMMERGAS anti-backflow kit to be used upstream of the cold water inlet connection of the appliance. We also recommend using category 2 heat transfer fluid (e.g.: water+ glycol) in the appliance's primary circuit (C.H. circuit), as defined in standard EN 1717.



To preserve the duration of appliance efficiency features, in the presence of water whose features can lead to the deposit of lime scale, installation of the "polyphosphate dispenser" kit is recommended.

The dispenser cannot be installed inside the recessed frame.

### 3 bar safety valve

Discharge of the safety valve has been conveyed to the condensate drain trap outlet. Consequently, in the event of valve intervention, the discharged liquid will end up in the sewer system through the drain pipe of the condensate drain trap.

In any case, the lower part of the appliance is fitted with a drain fitting (Ref. 3, Fig. 11) with the relative closure cap to check for the presence of liquid in the discharge circuit and to check the intervention of the 3 bar safety valve.

### Condensate drain

To drain the condensate produced by the appliance, it is necessary to connect to the drainage system by means of acid condensate resistant pipes, with an internal Ø of at least 13 mm.

The system connecting the appliance to the drainage system must be carried out in such a way as to prevent occlusion and freezing of the liquid contained in it.

Before appliance ignition, ensure that the condensate can be correctly removed. After first ignition, check that the drain trap is filled with condensate (Parag. 1.37).

Also, comply with national and local regulations on discharging waste waters.

In the event condensate is not discharged into the wastewater drainage system, a condensate neutraliser must be installed to ensure compliance with the parameters established by the legislation in force.

### Outdoor unit hydraulic connection

For the hydraulic connection of the Audax.DK4 outdoor unit, refer to the related instructions booklet.



Hydraulic connection diagram.

INSTALLER

USER

CONTROL PANEL

MAINTENANCE TECHNICIAN

TECHNICAL DATA

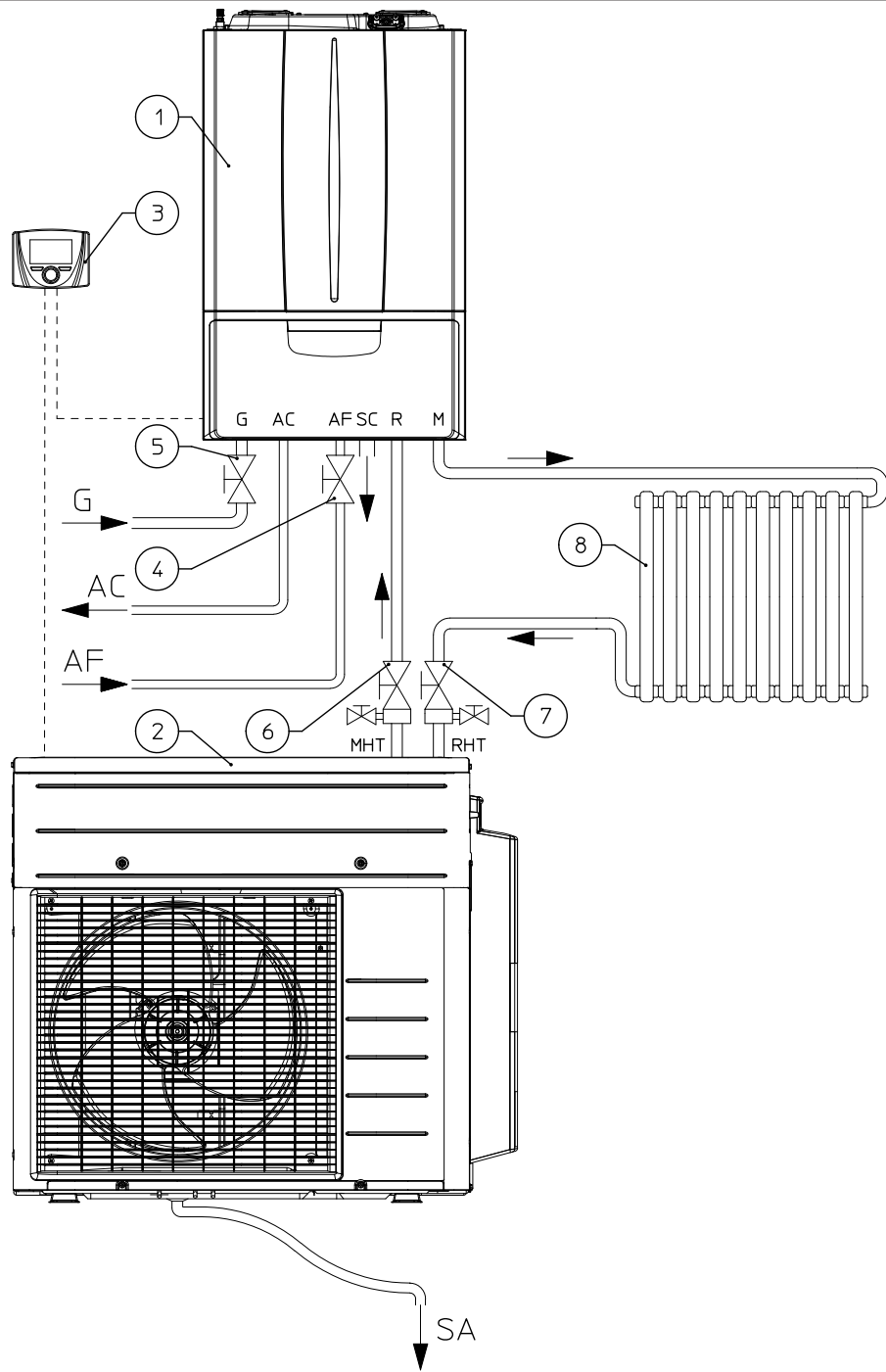

Key (Fig. 12):

- 1 - Indoor unit
- 2 - Audax.DK4 outdoor unit
- 3 - Control panel
- 4 - Domestic hot water inlet shut-off valve
- 5 - Gas interception valve
- 6 - Heat pump flow interception valve with vent
- 7 - Heat pump return interception valve with vent
- 8 - System

- G - Gas supply
- AC - Domestic hot water outlet
- AF - Domestic hot water inlet
- SC - Condensate drain
- M - System flow
- R - System return
- MHT - Flow from heat pump
- RHT - Return to heat pump
- SA - Outdoor unit water drain



## 1.13 ELECTRICAL CONNECTION

The indoor unit must be coupled with an Audax.DK4 outdoor unit. They must both be connected to the control panel as indicated in the wiring diagram. The Audax.DK4 outdoor unit is supplied with 230 Vac with lines separated from the indoor unit with an IPX5D protection rating. Electrical safety of the heat pump is reached only when all the units are correctly connected to an efficient earthing system as specified by current safety standards.



The manufacturer declines any responsibility for damage or physical injury caused by failure to connect the appliance to an efficient earthing system or failure to comply with the IEC reference standards.

### Indoor Unit electrical connection.

- **Open the control panel connections compartment (Fig. 13).**

To carry out electrical connections, all you have to do is open the connections compartment as follows.

1. Remove the front panel (Fig.83).
2. Disassemble the cover (b).
3. Loosen the screw (a).
4. Press the two hooks on the connections compartment cover.
5. Remove the cover (b) from the control panel (c).

At this point, it is possible to access the terminal board (d).

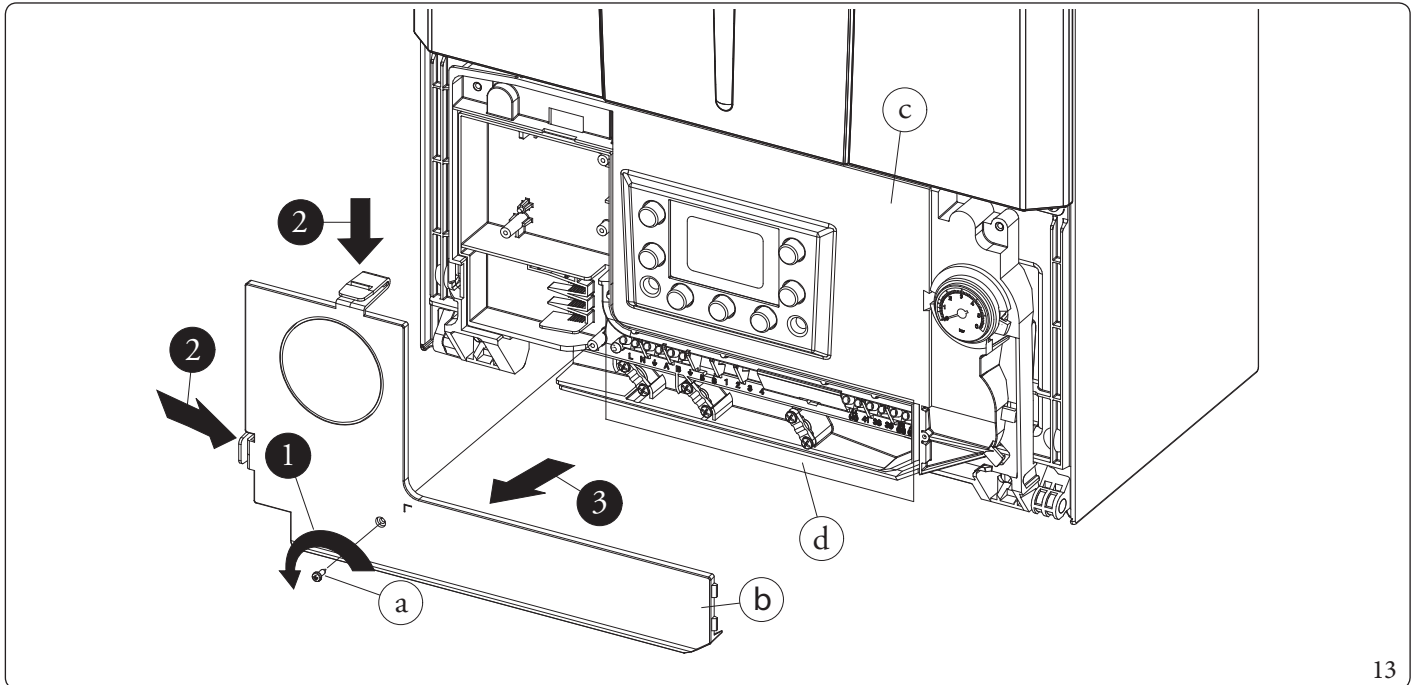

13

Also ensure that the electrical installation corresponds to maximum absorbed power specifications as shown on the appliance data nameplate.

Indoor units are supplied complete with an "X" type power cable without plug.



**The power supply cable must be connected to a 230V  $\pm$ 10% / 50Hz mains supply respecting L-N polarity and earth connection; this network must also have a multi-pole circuit breaker with class III overvoltage category in compliance with installation regulations.**



**To protect from possible leakage of DC voltage, it is necessary to provide a type A or type F residual current safety device with 30 mA sensitivity.**





If the power cable is damaged, contact a qualified company (e.g. the Authorised Technical Assistance Centre) for its replacement to avoid a hazard.



It is recommended to contact a qualified company (e.g. the Authorised After-Sales Technical Assistance Centre) for replacement to avoid a hazard.

The power supply cable must be laid as shown (Fig. 11).

If the network fuse indicated in the wiring diagram (Fig. 78) as component "F1" on the P.C.B. needs to be changed, this operation must also be performed by qualified personnel using a 3.15A rapid type (F) 250VAC fuse (dimension 5 x 20).

For the general power supply of the indoor unit from the mains, the use of adapters, power strips and extension cables is not permitted.

Make the various electrical connections according to your needs.

**Outdoor unit electrical connection.**

For the electrical connection of the Audax.DK4 outdoor unit, refer to the related instructions booklet.



## Electrical connection diagram Victrix Hybrid

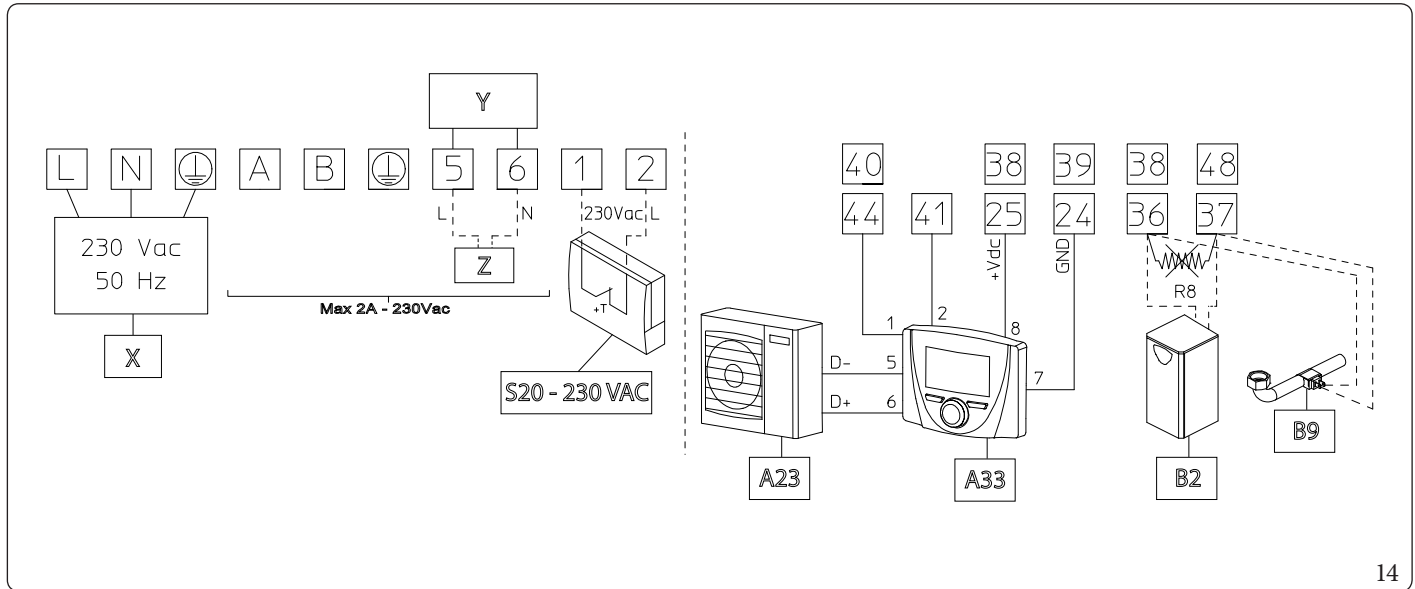

Key (Fig. 14):

- |   |  |
|---|--|
| A23 - Audax.DK4 Outdoor Unit                                      | S20-230VAC - Domestic hot water inlet probe (optional) |
| A33 - Victrix Hybrid control panel                                | X - Power supply                                       |
| B2 - Storage tank probe (optional - not available for this model) | Y - Configurable relay                                 |
| B9 - DHW inlet probe (optional - not available for this model)    | Z - Configurable output                                |

A 230VAC (optional) room thermostat can be connected on terminals 1 and 2 of the terminal block present in the indoor unit. For the connection, see 1.17.

To connect the Audax.DK4 outdoor unit to the control panel, connect the communication cables from terminals "D+ - D-" of the outdoor unit to terminals "5 - 6" of the control panel. Consult the relative instructions manual to access the electrical connections of the outdoor unit.

To connect the communication BUS of the outdoor unit to the control panel, connect the communication cables from terminals "44 - 41" of the indoor unit to terminals "1 - 2" of the control panel.

For low voltage power supply of the control panel, connect the communication cables from terminals "24-25" present on the terminal block of the indoor unit to terminals "7-8" of the control panel.

To connect the optional DHW input probe, connect the cables to terminals "38 - 48" on the terminal board of the indoor unit.

### 1.14 CONTROL PANEL MAIN DIMENSIONS

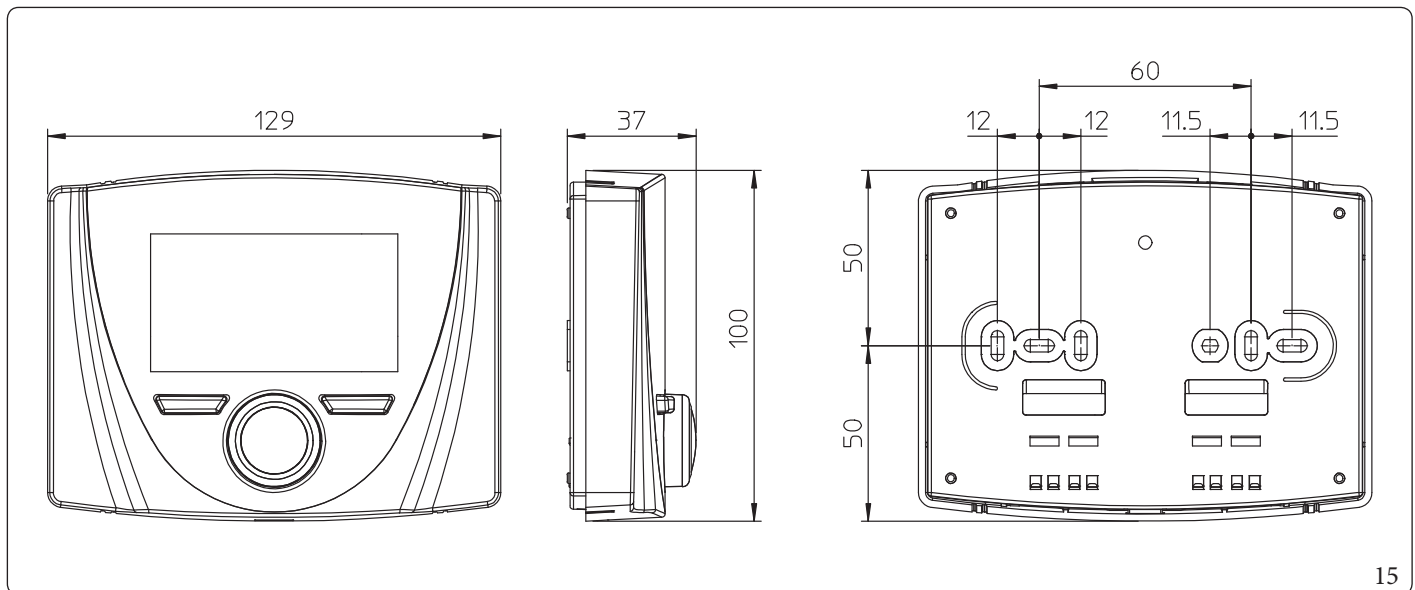

## 1.15 CONTROL PANEL INSTALLATION OPERATIONS

1. Separate the fixing template from the body of the control panel using a screwdriver as a lever in the relative recess (Fig. 16). Install the control panel away from heat sources and in a suitable position to detect the room temperature correctly.
2. Install the control panel using the openings on its rear part directly onto the wall or on a recess box using the relative supplied screws.
3. Then connect the control panel to the terminals of both units as shown in the wiring diagram. The connection is made using wires with a minimum section of 0.50 mm<sup>2</sup> and maximum section of 1.5 mm<sup>2</sup> and with a maximum length of 50 metres.

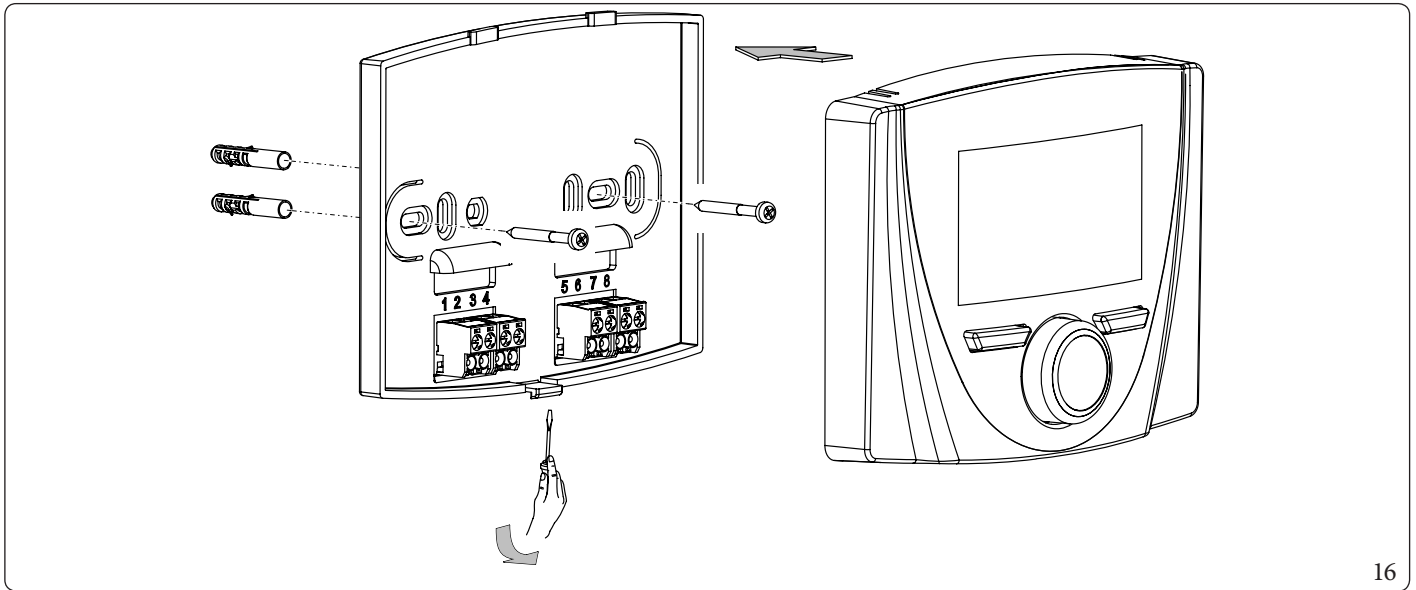

16



For correct installation, prepare a dedicated line to connect the control panel according to the Standards in force regarding electrical systems. If this is not possible, interference due to other electric cables could cause malfunctioning of the control panel itself.

4. Fix the body of the control panel to the mount template, engaging it with pressure.
5. After the Victrix Hybrid devices have been powered, wait about 30 seconds before regulation so that communication between control panel and the Victrix Hybrid devices has established.

## 1.16 EXTERNAL TEMPERATURE PROBE

In the outdoor unit there is an external probe as standard. This may be used by the control panel to manage temperature control.



Optional external probes may not be connected to the indoor or outdoor units.

## 1.17 REMOTE CONTROLS AND ROOM CHRONO-THERMOSTATS (OPTIONAL)

The appliance is set up for room chrono-thermostats or remote controls, available as optional kits.



The control panel must be installed even when using a room chrono-thermostat.



If remote controls are installed, they could control some functions of the installed kits. For further information, please contact your authorised Immergas Technical Service Centre.

The room thermostat, if commercial, must be suitable for crossing the 230Vac phase; when the thermostat is closed, 230Vac continuity (phase only) is given between terminals 1 and 2. The thermostat must be connected to terminals 1 and 2 as shown on the wiring diagram. Make sure that the On/Off contact of the thermostat is of the “clean” type.

The connections must be made on the terminal board inside the indoor unit control panel. To disassemble the cover to access the control panel, refer to Par.1.13.





**Terminals 1 and 2 of the indoor unit are 230V/50Hz.**

All Immergas chrono-thermostats are connected with 2 wires only.  
Carefully read the user and assembly instructions contained in the accessory kit.



**Disconnect power to the unit before making any electrical connections.**

The chrono-thermostat allows:

- set two room temperature value: one for day (comfort temperature) and one for night (reduced temperature);
- set a weekly programme with four daily switch on and switch off times;
- selecting the required function mode from the various possible alternatives:
  - manual mode (with adjustable temperature);
  - automatic mode (with set programme);
  - forced automatic operation (momentarily changing the temperature of the automatic program).

The chrono-thermostat is powered by two 1.5V LR6 type alkaline batteries.

### 1.18 230 VAC CONFIGURABLE OUTLET

A configurable relay is available on the P.C.B. of the indoor unit, its outlet is available on terminals 5 and 6 (to disassemble the cover to access the connections compartment of the control panel refer to Par.1.13).

The configurations that can be set for parameter "P3" are listed in the P.C.B. programming paragraph.



# 1.19 GENERALEXAMPLES OF TYPES OF INSTALLATION OF FLUE SYSTEMS



For the types of installation of flue systems approved for this product, please follow the table in Parag. 5.3, in the line "Type of flue installation".

INSTALLER

USER

CONTROL PANEL

MAINTENANCE TECHNICIAN

TECHNICAL DATA

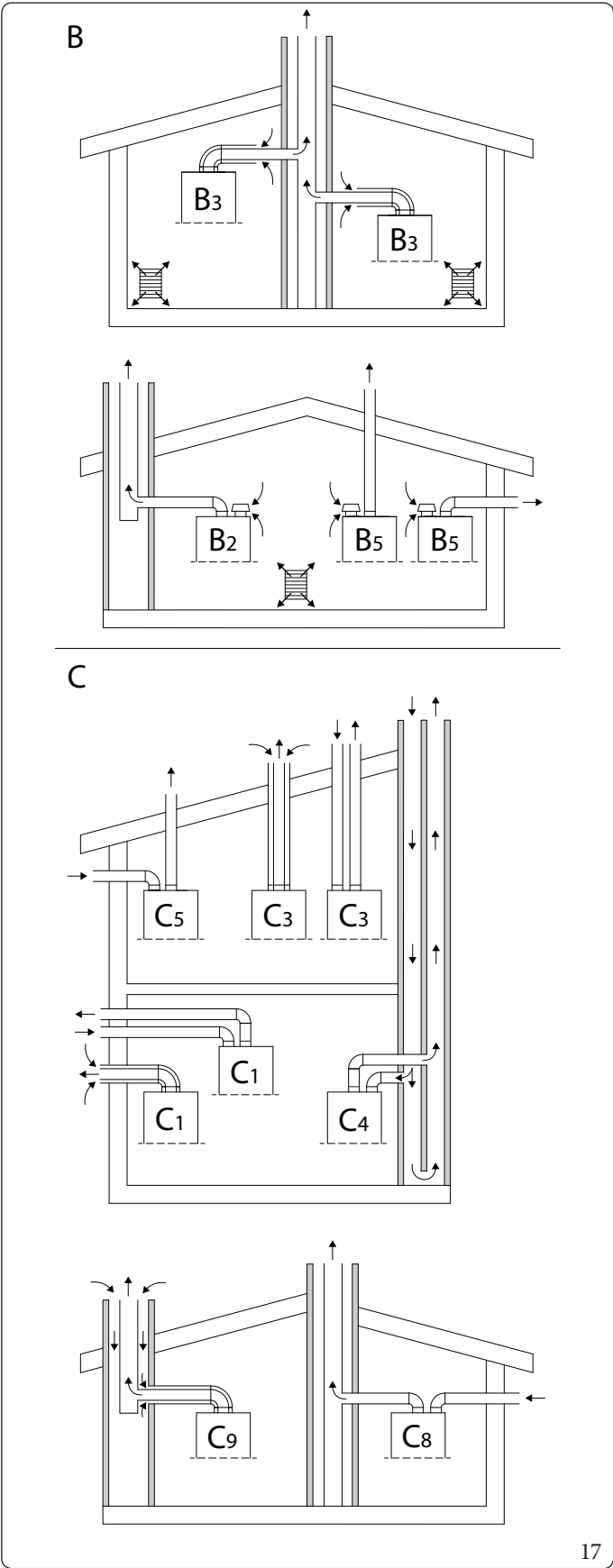

Installation types summarised table (Fig. 17):	
B	Appliance that withdraws air from the environment where it is installed and releases combustion products outside (either directly or through the flue).
B <sub>2</sub>	Appliance that withdraws air from the environment where it is installed and releases combustion products in the flue.
B <sub>3</sub>	Appliance connected to a conventional flue. A concentric pipe connects the flue to the appliance, in which the pressurised exhaust pipe is completely enveloped by combustion air withdrawn from inside the room. The combustion air is withdrawn by calibrated orifices present in the intake pipe.
B <sub>5</sub>	Appliance that withdraws air from the environment where it is installed and directly releases combustion products outside (through wall or roof).
C	Appliance whose combustion circuit (air feed, combustion chamber, heat exchanger and exhaust of combustion products) is sealed with respect to the room where the appliance is installed.
C <sub>1</sub>	Appliance with pipes connecting to a horizontal terminal, which simultaneously allows the inlet of combustion air and the release of flue gas through concentric orifices or close enough to be in similar wind conditions.
C <sub>3</sub>	Appliance with pipes connecting to a vertical terminal, which simultaneously allows the inlet of combustion air and the release of flue gas through concentric orifices or close enough to be in similar wind conditions.
C <sub>4</sub>	Appliance with two separate pipes connecting to a collective conventional flue. The flue consists of two pipes, concentric or separate, with air intake in one and flue gas release in the other and are in similar wind conditions.
C <sub>5</sub>	Appliance that withdraws air from outside and directly releases combustion products outside (through wall or roof). These pipes can end up in different pressure zones.
C <sub>6</sub>	Type C appliance intended to be connected to an approved system and sold separately.
C <sub>8</sub>	Appliance connected, through the exhaust pipe, to an individual or collective conventional flue. A second pipe is provided for the intake of combustion air from outside.
C <sub>9</sub>	Appliance connected, through a ducted exhaust pipe, to a vertical terminal. The exhaust pipe, by means of the cavity, also acts as a combustion air intake pipe.







The technical combustion parameters (except configurations C<sub>6</sub>) are displayed in Paragraph Chapter 5.2 "Combustion parameters"



The technical data required for configuration C<sub>6</sub> (commercial flue) are indicated in Paragraph Chapter 1.31 "Configuration for C<sub>6</sub> flue installation".

## 1.20 IMMERGAS FLUE SYSTEMS

Immergas supplies various solutions separately from the appliances regarding the installation of air intake and flue exhaust terminals, which are fundamental for appliance operation.

These solutions form an integral part of the product.



The appliance must be installed with an original Immergas "Green Range" inspectionable air intake system and flue gas extraction system made of plastic, with the exception of configuration C<sub>6</sub> in the configurations envisaged in Parag. 1.19, as required by the regulations in force and by the product's approval. This flue can be identified by an identification mark and special distinctive marking bearing the note "only for condensation boilers".

For non-original flue system, refer to the technical data of the appliance.



The plastic pipes cannot be installed outdoors, for tracts longer than 40 cm, without suitable protection from UV rays and other atmospheric agents.



**Positioning the gaskets (black) for “green range” flue systems.**

Position the gasket correctly (for bends and extensions) (Fig. 18):

- gasket (A) with notches, to use for bends;
- gasket (B) without notches, to use for extensions.

If necessary, to ease the push-fitting, spread the supplied lubricants on the parts.

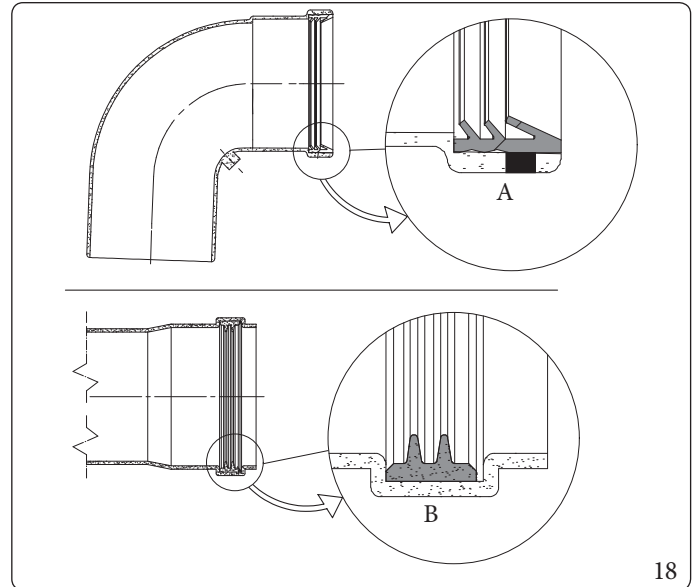

18

**Extension pipes and concentric elbows push-fittings.**

To install push-fitting extensions with other elements of the flue, proceed as follows:

- Install the concentric pipe or elbow with the male side (smooth) on the female side (with lip seal) to the end stop on the previously installed element in order to ensure sealing efficiency of the coupling.



If the exhaust terminal and/or extension concentric pipe needs shortening, consider that the internal duct must always protrude by 5 mm with respect to the external duct.



**For safety purposes, do not even temporarily obstruct the appliance intake/exhaust terminal.**







**The various parts of the flue system must be checked to ensure that they have been laid in such a way as to prevent the coupled parts from detaching, in particular, the flue exhaust duct in the Ø80 separator kit configuration. If the condition described above is not adequately guaranteed, it will be necessary to use the appropriate retaining clamp kit.**



When installing horizontal pipes, a minimum inclination of 5% towards the appliance must be maintained, and a section clamp with plug must be installed every 3 metres.









## 1.21 EQUIVALENT LENGTHS OF "GREEN RANGE" FLUE SYSTEM COMPONENTS.

Equivalent concentric lengths Ø 60/100				
Ø duct [mm]	Type of duct	Picture	Equivalent length in [m] of concentric pipe Ø 60/100 mm	
60/100	Pipe Ø 60/100 mm L = 1 m			1,0
	90° bend Ø 60/100 mm			1,3
	45° bend Ø 60/100 mm			1,0
	Horizontal terminal Ø 60/100 mm L = 1 m			
	Horizontal terminal Ø 60/100 mm L = 1 m adjustable		0° spout	
			45° spout	
Vertical terminal Ø 60/100 mm L = 1,25 m				



The values of the equivalent lengths in metres of concentric pipe of the Ø60/100 terminals are not the actual ones, but are weighted values to be used for the calculation of the flue.

Equivalent concentric lengths Ø 80/125				
Ø duct [mm]	Type of duct	Picture	Equivalent length in [m] of concentric pipe Ø 80/125 mm	
80/125	Pipe Ø 80/125 mm L = 1 m			1,0
	90° bend Ø 80/125 mm			1,4
	45° bend Ø 80/125 mm			1,0
	Reduction kit from Ø 60/100 to Ø 80/125 mm			0,5
	Horizontal terminal Ø 80/125 mm L = 0,75 m			
	Horizontal terminal Ø 80/125 mm L = 1 m			
	Vertical terminal Ø 80/125 mm L = 1 m			

INSTALLER













USER









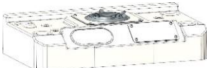









CONTROL PANEL

MAINTENANCE TECHNICIAN

TECHNICAL DATA



Equivalent lengths split Ø 80/80 and rigid ducting Ø 80				
Ø duct [mm]	Type of duct	Picture	Equivalent length in [m] of pipe Ø 80 mm	
			Exhaust	Intake
80/80 and rigid 80	Pipe Ø 80 mm L = 1 m		Exhaust	1,0
	90° bend Ø 80 mm		Exhaust	2,1
			Intake	1,6
	45° bend Ø 80 mm		Exhaust	1,3
			Intake	1,0
	Horizontal terminal Ø 80 mm L = 1 m		Exhaust	3,5
			Intake	2,5
	Horizontal terminal Ø 80 mm grid part		Exhaust	2,5
			Intake	1,8
	Vertical terminal Ø 80 mm L = 1 m		Exhaust	3,0
	Stainless steel vertical terminal Ø 80 mm L = 1 m		Exhaust	3,0
	Suction kit Ø 80 mm for configuration B		Intake	4,3
	Vertical terminal Ø 80 mm L = 1,25 m		Exhaust	4,6
	Pipe Ø 80/125 mm L = 1 m			1,8
	90° bend Ø 80/125 mm			2,5
45° bend Ø 80/125 mm			1,8	
Reduction kit from Ø 60/100 to Ø 80/125 mm			0,9	
Thermoformed kit for type B installation		Intake	4,0	

Equivalent lengths Ø 50 flexible ducting				
Ø duct [mm]	Type of duct	Picture	Equivalent length in [m] of flexible hose Ø 50 mm	
50Hose	Corrugated hose Ø 50 mm L = 1 m		Exhaust	1,0
	Kit T Ø 80 mm + reduction to Ø 50 mm		Exhaust	0,6
	Exhaust T-terminal kit Ø 80 mm + reduction to Ø 50 mm		Exhaust	1,0
	Ø 80 mm bend kit + reduction to Ø 50 mm		Exhaust	1,2
	Vertical terminal Ø 80 mm + reduction to Ø 50 mm		Exhaust	0,5
	Female/female kit Ø 50 mm		Exhaust	0,4
	Pipe Ø 80 mm L = 1 m		Exhaust	0,1
			Intake	0,1
	90° bend Ø 80 mm		Exhaust	0,3
			Intake	0,2
	45° bend Ø 80 mm		Exhaust	0,2
			Intake	0,1
	Horizontal terminal Ø 80 mm L = 1 m			
			Intake	0,3
	Horizontal terminal Ø 80 mm grid part			
			Intake	0,2
	Pipe Ø 60/100 mm L = 1 m			0,6
	90° bend Ø 60/100 mm			0,8
	45° bend Ø 60/100 mm			0,6
	Pipe Ø 80/125 mm L = 1 m			0,2
90° bend Ø 80/125 mm			0,3	
45° bend Ø 80/125 mm			0,2	
Reduction kit from Ø 60/100 to Ø 80/125 mm			0,1	
Suction kit Ø 80 mm for configura- tion B		Intake	0,5	

INSTALLER













USER





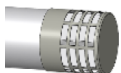













CONTROL PANEL

MAINTENANCE TECHNICIAN

TECHNICAL DATA



Equivalent ducting lengths Ø 60 rigid				
Ø duct [mm]	Type of duct	Picture	Equivalent length in [m] of rigid pipe Ø 60 mm	
60 rigid	Pipe Ø 60 mm L = 1 m		Exhaust	1,0
	90° bend Ø 60 mm		Exhaust	1,1
	45° bend Ø 60 mm		Exhaust	0,6
	Vertical terminal Ø 60 mm L = 1 m		Exhaust	3,7
	Reduction Ø 80 to Ø 60 mm		Exhaust	0,8
	Pipe Ø 80 mm L = 1 m		Exhaust	0,4
			Intake	0,3
	90° bend Ø 80 mm		Exhaust	0,8
			Intake	0,6
	45° bend Ø 80 mm		Exhaust	0,5
			Intake	0,4
	Horizontal terminal Ø 80 mm L = 1 m		Intake	0,9
	Horizontal terminal Ø 80 mm grid part		Intake	0,7
	Pipe Ø 60/100 mm L = 1 m		Exhaust	2,0
	90° bend Ø 60/100 mm		Exhaust	2,5
45° bend Ø 60/100 mm		Exhaust	2,0	
Suction kit Ø 80 mm for configuration B		Intake	1,6	

Equivalent lengths Ø 80 flexible ducting				
Ø duct [mm]	Type of duct	Picture	Equivalent length in [m] of flexible hose Ø 80 mm	
			Exhaust	Intake
80 Hose	Corrugated hose Ø 80 mm L = 1 m		Exhaust	1,0
	70° bend Ø 80 mm		Exhaust	1,0
	T-kit Ø 80 mm		Exhaust	1,1
	T-shaped exhaust terminal Ø 80 mm		Exhaust	1,6
	Vertical terminal Ø 80 mm		Exhaust	0,7
	Adapter Ø 80 mm flexible/male		Exhaust	0,2
	Adapter Ø 80 mm flexible/flexible		Exhaust	0,2
	Adapter Ø 80 mm flexible/flexible		Exhaust	0,3
	Vertical terminal Ø 80mm L = 1,25 m		Exhaust	1,7
	Pipe Ø 80 mm L = 1 m		Exhaust	0,4
			Intake	0,3
	90° bend Ø 80 mm		Exhaust	0,8
			Intake	0,6
	45° bend Ø 80 mm		Exhaust	0,5
			Intake	0,4
	Horizontal terminal Ø 80 mm L = 1 m		Intake	0,9
			Intake	0,7
	Horizontal terminal Ø 80 mm grid part		Intake	0,7
	Pipe Ø 80/125 mm L = 1 m			0,7
	90° bend Ø 80/125 mm			0,9
	45° bend Ø 80/125 mm			0,7
	Reduction kit from Ø 60/100 to Ø 80/125 mm			0,3
	Suction kit Ø80 mm for configuration B		Intake	1,6

INSTALLER









USER







CONTROL PANEL

MAINTENANCE TECHNICIAN

TECHNICAL DATA



Equivalent lengths $C_{10}$ - $C_{12}$ concentric $\varnothing$ 80/125 mm				
$\varnothing$ duct [mm]	Type of duct	Picture	Equivalent length in [m] of pipe $C_{10}$ - $C_{12}$ concentric $\varnothing$ 80/125 mm	
			Exhaust	
$C_{10}$ - $C_{12}$ 80/125	Clapet $\varnothing$ 80 mm		Exhaust	
	Pipe $\varnothing$ 80/125 mm L = 1 m			1,0
	90° bend $\varnothing$ 80/125 mm			1,4
	45° bend $\varnothing$ 80/125 mm			1,0
	Reduction kit from $\varnothing$ 60/100 to $\varnothing$ 80/125 mm			0,5
	Pipe $\varnothing$ 80 mm L = 1 m		Exhaust	0,6
	90° bend $\varnothing$ 80 mm		Exhaust	1,2
	45° bend $\varnothing$ 80 mm		Exhaust	0,7

Equivalent lengths $C_{10}$ - $C_{12}$ split $\varnothing$ 80/80 mm				
$\varnothing$ duct [mm]	Type of duct	Picture	Equivalent length in [m] of $C_{10}$ - $C_{12}$ split pipe $\varnothing$ 80/80 mm	
			Exhaust	Intake
$C_{10}$ - $C_{12}$ 80/80	Clapet $\varnothing$ 80 mm		Exhaust	
	Pipe $\varnothing$ 80 mm L = 1 m		Exhaust	1,0
	90° bend $\varnothing$ 80 mm		Exhaust	2,1
			Intake	1,6
	45° bend $\varnothing$ 80 mm		Exhaust	1,3
			Intake	1,0
	Horizontal terminal $\varnothing$ 80 mm L = 1 m		Intake	2,5
	Horizontal terminal $\varnothing$ 80 mm grid part		Intake	1,8



## 1.22 MAXIMUM FLUE LENGTH



The maximum flue length ( $L_{max}$ ) is understood to include the terminal.



To calculate the equivalent length of the flue ( $L$ ), simply add, for each component you intend to use, the corresponding value indicated in the column "Length equivalent to m of pipe" in the table in par. 1.21, and check that the resulting sum is equal to or less than the maximum length ( $L_{max}$ ) indicated in par. 1.22. ( $L \leq L_{max}$ ).



Should  $L$  be higher than  $L_{max}$ , consider using another type of flue.

Type	Installation		VICTRIX 24HY
			$L_{max}$ = Maximum length (m)
Ø 60/100mm	$C_{13}$ (horizontal+elbow)		13
	$C_{33}$ (vertical)		14,5
Ø 80/125mm	$C_{13}$ (horizontal+elbow) $C_{33}$ (vertical)		35
Ø 80/80mm	$C_{43}$ - $C_{53}$ - $C_{83}$ (split)		35
	$B_{23}$ - $B_{33}$ - $B_{53p}$		30
Ø 50 flexible	$C_{53}$	Split duct 80/80 from boiler to connection in flue	8
Ø 60mm rigid			25
Ø 80mm rigid			35
Ø 80 flexible			30
Ø 50 flexible	$C_{93}$	Concentric 60/100 or 80/125 from boiler to flue	8
Ø 60mm rigid			25
Ø 80mm rigid			35
Ø 80 flexible			30

INSTALLER

USER

CONTROL PANEL

MAINTENANCE TECHNICIAN

TECHNICAL DATA



Type	Installation		VICTRIX 32HY
			L <sub>max</sub> = Maximum length (m)
Ø 60/100mm	C <sub>13</sub> (horizontal+elbow)		13
	C <sub>33</sub> (vertical)		14,5
Ø 80/125mm	C <sub>13</sub> (horizontal+elbow) C <sub>33</sub> (vertical)		35
Ø 80/80mm	C <sub>43</sub> - C <sub>53</sub> - C <sub>83</sub> (split)		35
	B <sub>23</sub> - B <sub>33</sub> - B <sub>53p</sub>		30
Ø 50 flexible	C <sub>53</sub>	Split duct 80/80 from boiler to connection in flue	8
Ø 60mm rigid			25
Ø 80mm rigid			35
Ø 80 flexible			30
Ø 50 flexible	C <sub>93</sub>	Concentric 60/100 or 80/125 from boiler to flue	8
Ø 60mm rigid			25
Ø 80mm rigid			35
Ø 80 flexible			30



The values indicated in the table are the maximum available lengths.

Adjustment of the maximum boiler speed depending on the length of the actual pipes installed must refer to the Table in Par. 4.8.

The flue parameter (heat output) must be calibrated by the maintenance technician at initial testing.

### Example of flue length calculation.

In the example of a concentric system (Fig. 19), the following dimensions must be added together to calculate the equivalent length of the flue (L):

$$L = T1 + C2 + T2 + C3 + C4 + TS$$

$$L = 1 + 1,3 + 1 + 1 + 1 + 1 = 6,3\text{m}$$

$$L \leq L_{\text{max}} (6,3\text{m} \leq 13\text{m})$$

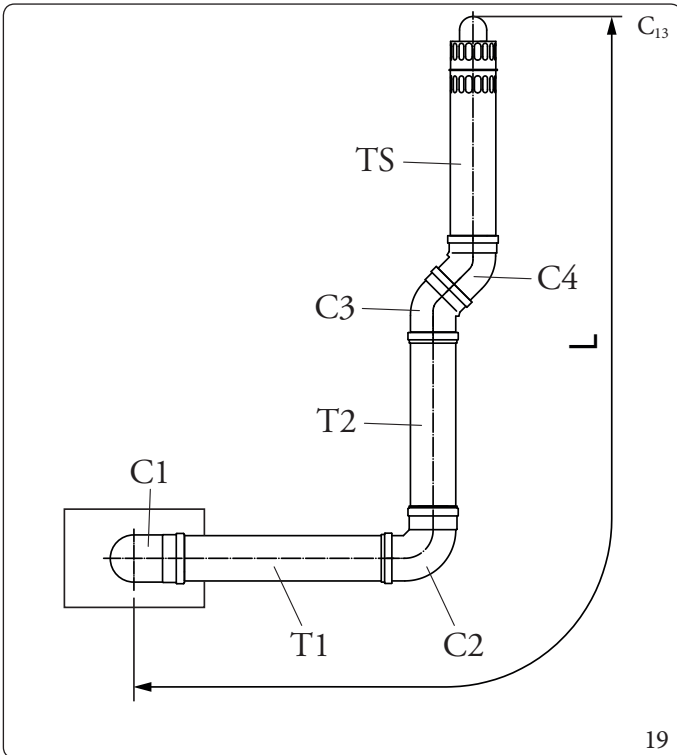

Key (Fig. 19):

- T1 - Concentric pipe  $\varnothing$  60/100
- T2 - Concentric pipe  $\varnothing$  60/100
- C1 - 90° concentric elbow  $\varnothing$  60/100 (do not consider when calculating the equivalent length)
- C2 -  $\varnothing$  60/100 90° concentric elbow
- C3 - Concentric elbow 45°  $\varnothing$  60/100
- C4 - Concentric elbow 45°  $\varnothing$  60/100
- TS - Horizontal terminal complete with concentric intake-exhaust  $\varnothing$  60/100
- L - Equivalent length
- L<sub>max</sub> - Maximum length

**i** To calculate the flue length of other types of installations, follow the logic illustrated in this example.



## 1.23 OUTDOOR INSTALLATION OR IN A PARTIALLY PROTECTED AREA



By partially protected area, we mean one in which the unit is not directly exposed to the elements (rain, snow, hail, etc.).



If the appliance is installed in a location where the ambient temperature falls below  $-5^{\circ}\text{C}$ , use the optional antifreeze kit, checking the ambient temperature range for operation in the technical data table in this instruction manual (Section 'Technical Data').



This type of installation is possible when permitted by the laws in force in the appliance's country of destination.

### Configuration type B, open chamber and fan assisted ( $B_{23}$ or $B_{53}$ ).

Using the relevant cover kit, direct air intake is possible and flue gas is exhausted into a single flue or directly to the outside. In this configuration it is possible to install the appliance in a partially protected place. In this configuration the appliance is classified as type B.

With this configuration:

- air intake takes place directly from the environment in which the appliance is installed (external);
- the flue gas exhaust must be connected to its own single chimney ( $B_{23}$ ) or ducted directly outside via a vertical terminal for direct exhaust ( $B_{53}$ ) or via an Immergas ducting system ( $B_{53}$ ).

The technical regulations in force must be respected.

### Cover kit assembly (Fig. 20).

Remove the two plugs from the lateral intake holes. Now cover the left intake hole using the relevant plate, fixing it onto the right side using the 2 previously-removed screws.

Install the  $\text{Ø} 80$  outlet flange on the central hole of the boiler, taking care to insert the gasket supplied with the kit and tighten by means of the screws provided.

Install the upper cover, fixing it using the 4 screws present in the kit, positioning the relevant gaskets.

Engage the  $90^{\circ}$   $\text{Ø} 80$  bend with the male end (smooth) in the female end (with lip seal) of the  $\text{Ø} 80$  flange unit to the end stop. Introduce the gasket, making it run along the bend. Fix it using the metal sheet plate and tighten by means of the clips present in the kit, making sure to block the 4 gasket flaps.

Fit the male end (smooth) of the exhaust pipe into the female end of the  $90^{\circ}$   $\text{Ø} 80$  bend, making sure that the relevant wall sealing plate is already fitted; this will ensure hold and joining of the elements making up the kit.

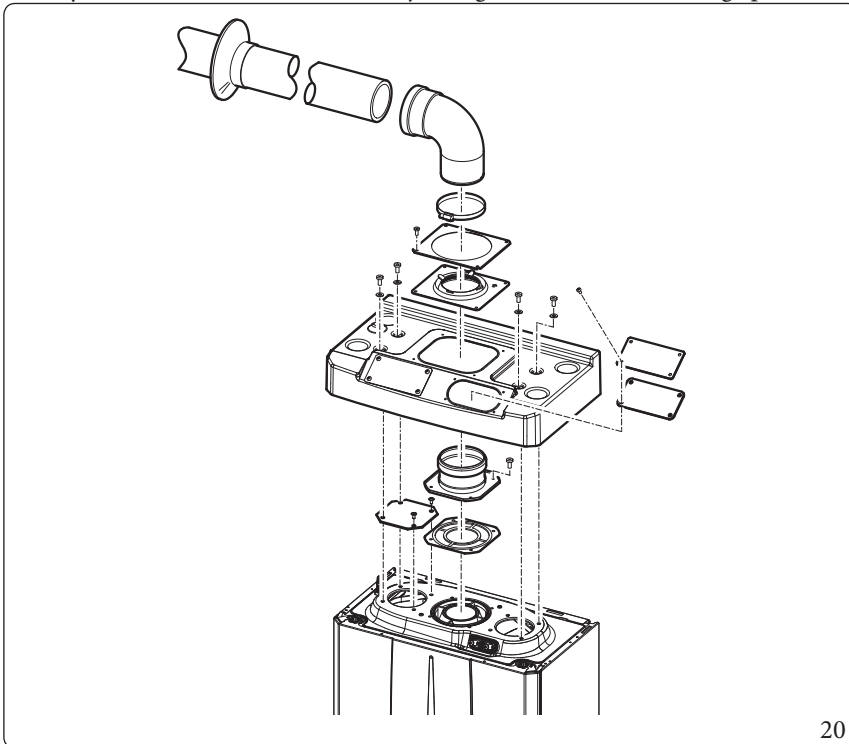

The cover kit includes (Fig. 20):

- N°1 Thermoformed cover
- N°1 Gasket clamping plate
- N°1 Gasket
- N°1 Gasket tightening clip
- N°1 Intake hole covering plate

Il kit terminale comprende:

- N°1 Gasket
- N°1 Exhaust flange  $\text{Ø} 80$
- N°1  $\text{Ø} 80$   $90^{\circ}$  bend
- N°1 Exhaust pipe  $\text{Ø} 80$
- N°1 Wall sealing plate

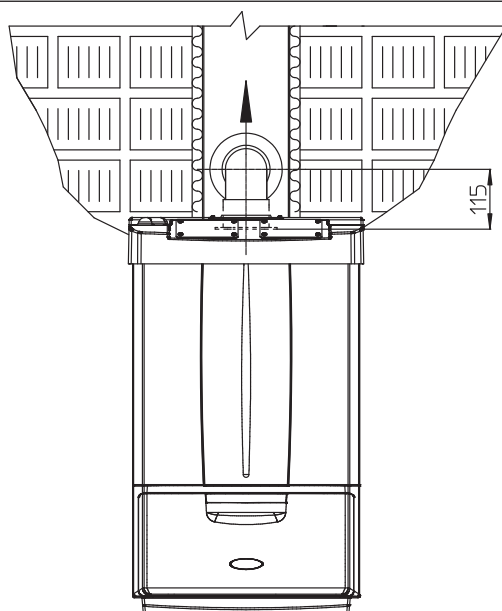

21

### Coupling of extension pipes.

To install push-fitting extensions with other elements of the flue, proceed as follows: Couple the pipe or elbow with the male side (smooth) in the female side (with lip seal) to the end stop on the previously installed element. This will ensure sealing efficiency of the coupling.

### Configuration without cover kit in a partially protected location (type C appliance).

By leaving the side plugs fitted, it is possible to install the appliance externally, in a partially covered place, without the cover kit. Installation takes place using the  $\varnothing 60/100$  and  $\varnothing 80/125$  concentric intake/ exhaust kits. Refer to the paragraph on indoor installation. In this configuration the top cover kit that guarantees additional protection for the appliance is recommended but not compulsory.



The top cover kit, which provides additional protection for the boiler, CANNOT be used with  $\varnothing 80/80$  separator configuration,  $\varnothing 60/100$  concentric and  $\varnothing 80/125$ .



## 1.24 INTERNAL INSTALLATION USING A RECESSED FRAME WITH DIRECT AIR INTAKE

### Configuration type B, open chamber and fan assisted

In this configuration the appliance is classified as type B<sub>23</sub>.

Using a kit separator, one can achieve direct air intake (Fig. 22) and flue exhaust in a single chimney or directly outside.

With this configuration:

- air intake takes place directly from the environment in which the appliance is installed and only functions in permanently ventilated rooms;
- the flue gas exhaust must be connected to its own individual chimney and channelled directly into the external atmosphere.

The technical regulations in force must be respected.

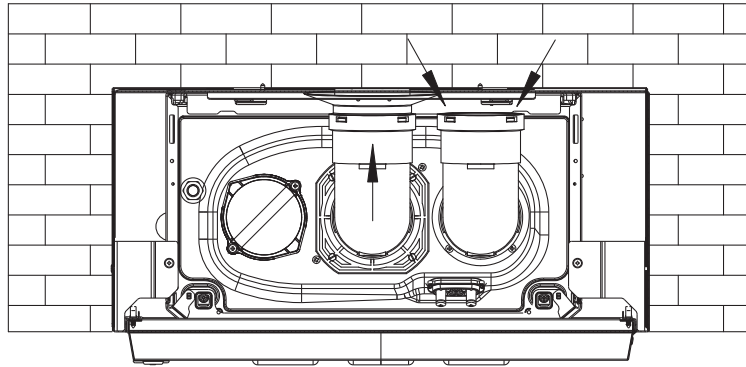

22

### Separator kit installation (Fig. 23).

1. Install the discharge flange on the middle hole of the appliance, positioning the relative gasket with the circular projections downwards in contact with the appliance flange, and tighten using the hex screws with flat tip contained in the kit.
2. Remove the flat flange present in the lateral hole with respect to the central one (according to needs) and replace it with the intake flange, positioning its gasket and tighten using the supplied self-threading screws.
3. Fit the curves with the male side (smooth) into the female side of the flanges (the intake curve must face the rear side of appliance).
4. Fit the exhaust pipe with the male side (smooth) to the female side of the bend up to the end stop, making sure that the internal wall sealing plate has been fitted and connecting the required flue according to personal requirements.

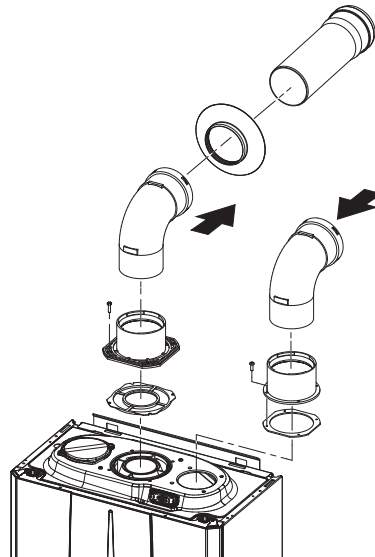

23

## 1.25 CONCENTRIC HORIZONTAL KIT INSTALLATION

### Type C configuration, sealed chamber and fan assisted

The position of the terminal (in terms of distances from openings, overlooking buildings, floor, etc.) must be in compliance with the regulations in force.

This terminal is connected directly to the outside of the building for air intake and flue gas exhaust.

The horizontal kit can be installed with the rear, right side, left side or front outlet.

For installation with frontal outlet, one must use the fixing plate and a concentric bend coupling in order to ensure sufficient space to carry out the tests required by law upon commissioning.

### External grid

Make sure that the external silicone wall sealing plate is properly inserted in the wall.



For correct functioning of the system the terminal with grid must be installed correctly ensuring that, the "high" indication present on the terminal is respected on installation.

### Horizontal intake/exhaust assembly kits Ø 60/100 (Fig. 24)

1. Install the curve with flange (2) on the central hole of the appliance, positioning gasket (1) with the circular projections downwards in contact with the appliance flange, and tighten using the screws contained in the kit.
2. Fit the Ø 60/100 (3) concentric terminal pipe with the male side (smooth) to the female side of the bend (2) up to the end stop, making sure that the internal and external wall sealing plates have been fitted; this will ensure sealing and joining of the elements making up the kit.

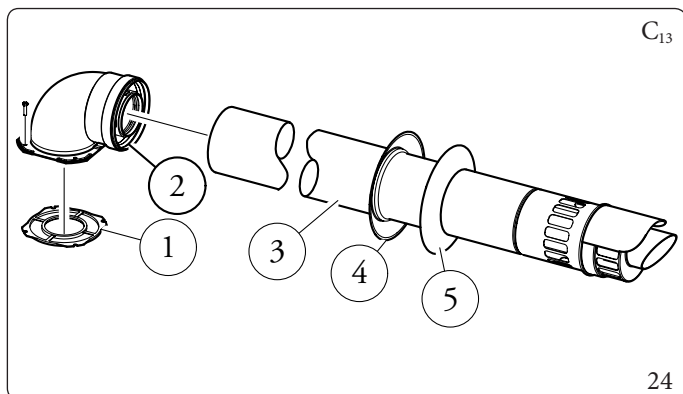

The kit includes (Fig. 24):

- N°1 Gasket (1)
- N°1 Concentric bend Ø 60/100 (2)
- N°1 Int./exhaust concentric terminal Ø 60/100 (3)
- N°1 Internal wall sealing plate (4)
- N°1 External wall sealing plate (5)

### Extensions for horizontal kit Ø 60/100 (L = Equivalent length - L max = Maximum length) (Fig. 25).

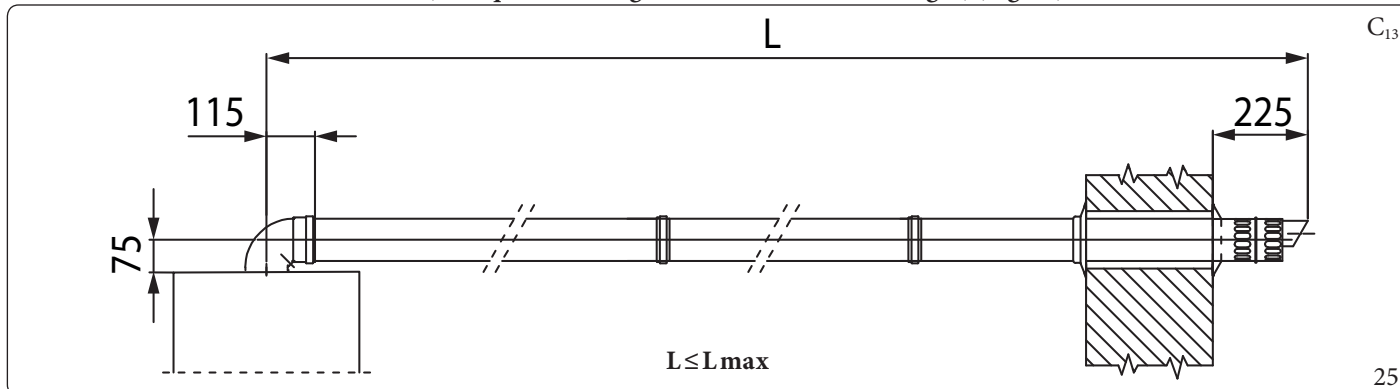

The maximum lengths ((L max) of the various flues that can be installed are given in the summary table in parag. 1.22.



**Installation examples**

Type of Duct	Minimum outlet height roof/wall (m)
	X
Concentric Ø 60/100 Horizontal	0,225

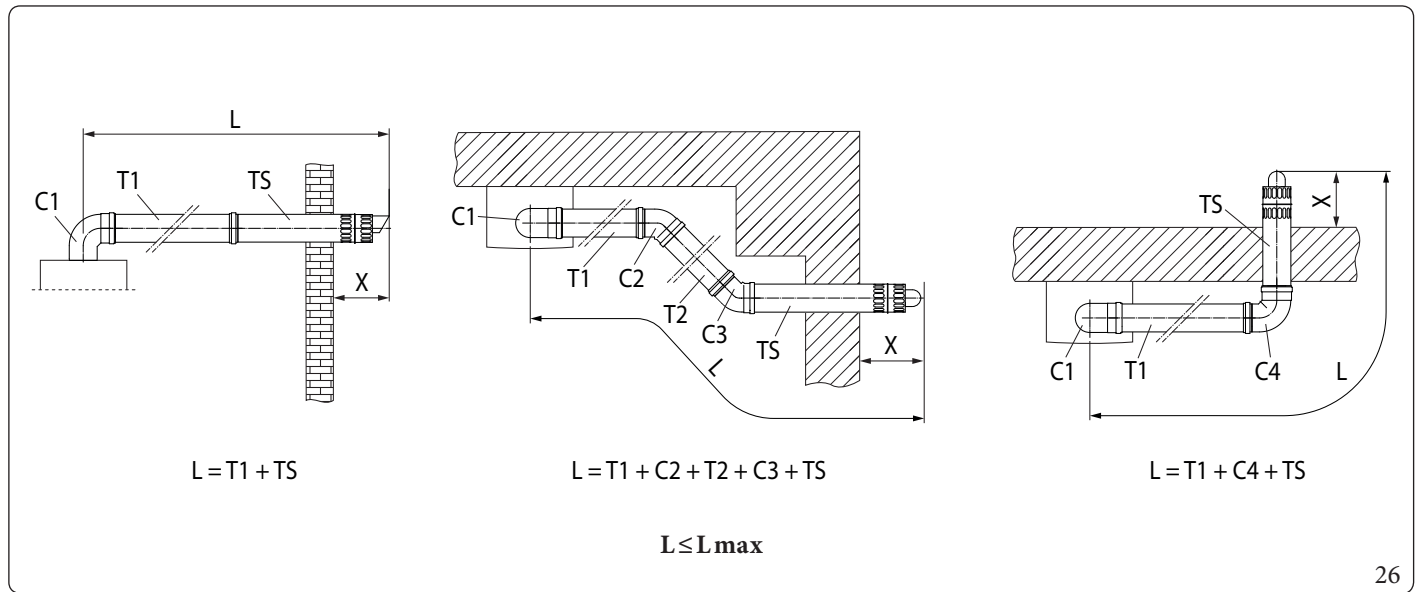

26

Key Fig. 26:

- T1 - Concentric pipe Ø60/100
- C1 - 90° concentric elbow Ø60/100 (do not consider when calculating the equivalent length)
- T2 - Concentric pipe Ø60/100
- C2 - Ø60/100 45° concentric elbow
- C3 - Ø60/100 45° concentric elbow
- C4 - Ø60/100 90° concentric elbow
- TS - Concentric intake/exhaust terminal Ø60/100
- L - Equivalent length
- Lmax - Maximum length



To calculate the equivalent length of the flue (L), simply add, for each component you intend to use, the corresponding value indicated in the column "Length equivalent to m of pipe" in the table in par. 1.21, and check that the resulting sum is equal to or less than the maximum length (L max) indicated in par. 1.22. ( $L \leq L_{max}$ ).



### Horizontal intake/exhaust assembly kits Ø 80/125 (Fig. 27)

To install the kit Ø 80/125 one must use the flanged adapter kit (pos. 2, Fig. 27).

1. Install the flanged adaptor (2) on the central hole of the appliance, positioning gasket (1) with the circular projections downwards in contact with the appliance flange, and tighten using the screws contained in the kit.
2. Engage the bend (3) with the male side (smooth) to the end stop on the adaptor (2).
3. Fit the Ø 80/125 (4) concentric terminal pipe with the male side (smooth) to the female side of the bend (3) (with lip seals) up to the end stop, making sure that the internal (5) and external wall sealing plates (6) have been fitted; this will ensure sealing and joining of the elements making up the kit.

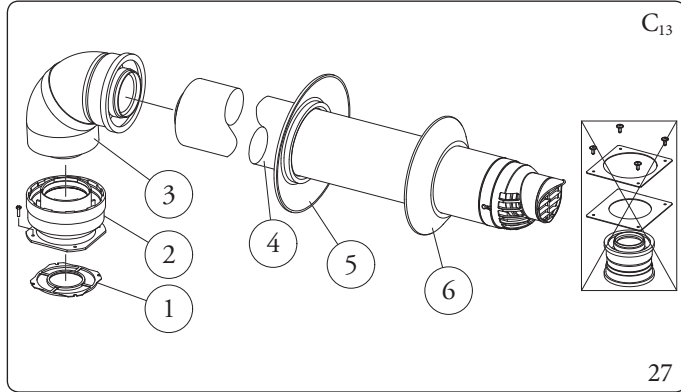

The adapter kit includes (Fig. 27):

- N°1 Gasket (1)
- N°1 Adapter Ø 80/125 (2)

The Ø 80/125 kit includes (Fig. 27):

- N°1 Concentric bend Ø 80/125 at 87° (3)
- N°1 Int./exhaust concentric terminal Ø 80/125 (4)
- N°1 Internal wall sealing plate (5)
- N°1 External wall sealing plate (6)

The remaining kit components must not be used

### Extensions for horizontal kit Ø 80/125 (L = Equivalent length - L max = Maximum length) (Fig. 28).

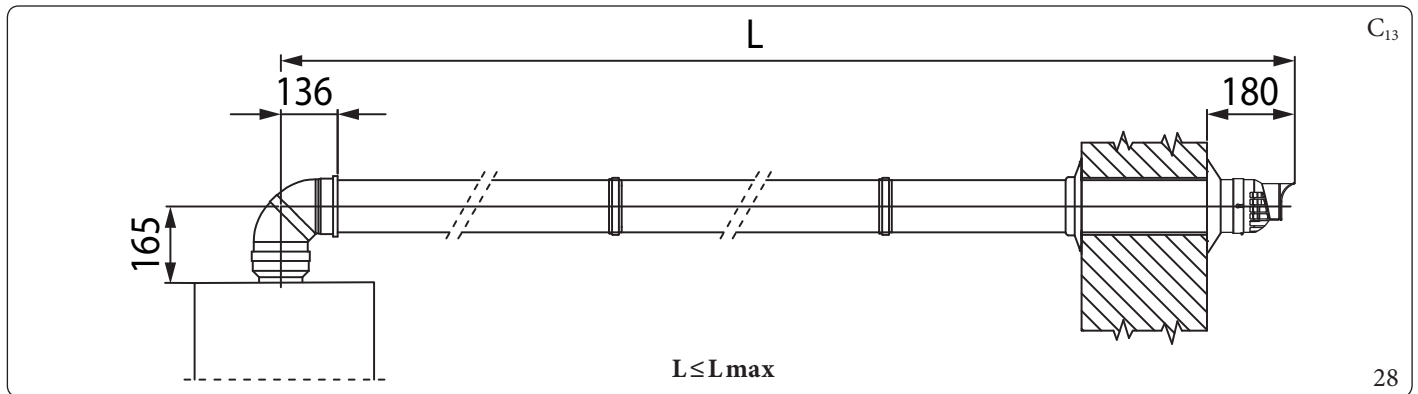

The maximum lengths ((L.max) of the various flues that can be installed are given in the summary table in parag. 1.22.

INSTALLER

USER

CONTROL PANEL

MAINTENANCE TECHNICIAN

TECHNICAL DATA



**Installation examples**

Type of Duct	Minimum outlet height roof/wall (m)
	X
Concentric Ø 80/125 Horizontal	0,18

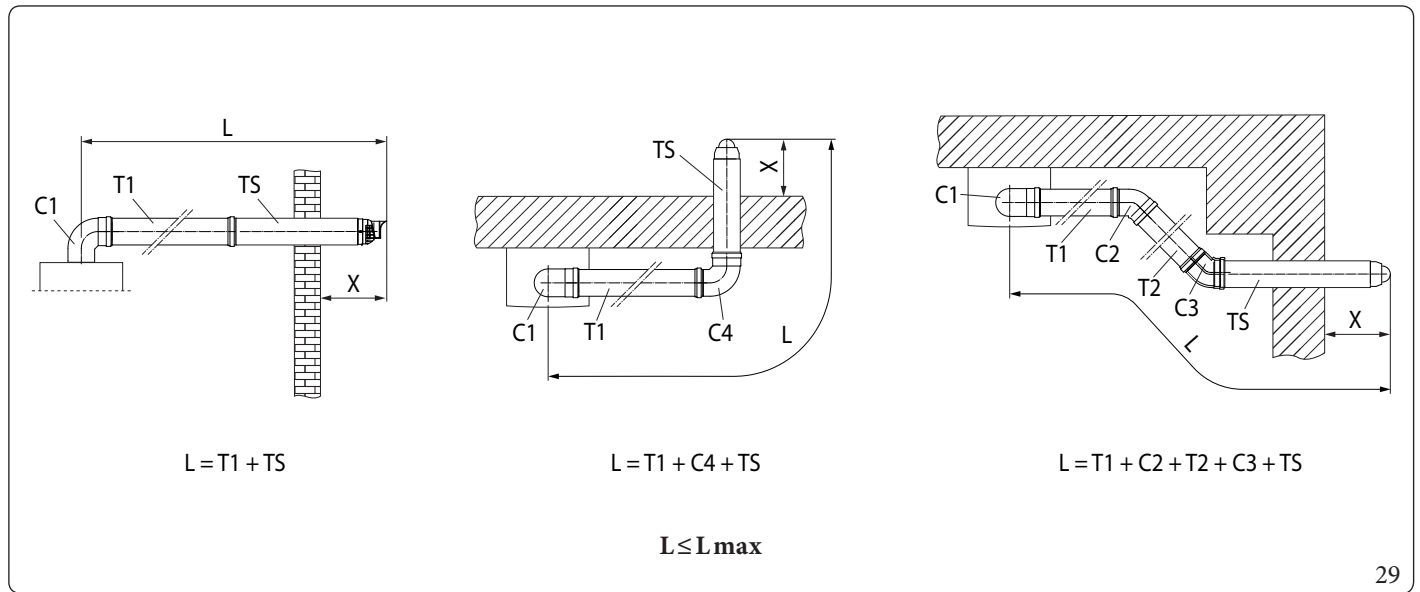

29

Key Fig. 29:

- T1 - Concentric pipe Ø80/125
- C1 - 90° concentric elbow Ø80/125 (do not consider when calculating the equivalent length)
- T2 - Concentric pipe Ø80/125
- C2 - Ø80/125 45° concentric elbow
- C3 - Ø80/125 45° concentric elbow
- C4 - Ø80/125 90° concentric elbow
- TS - Concentric intake/exhaust terminal Ø80/125
- L - Equivalent length
- Lmax - Maximum length



To calculate the equivalent length of the flue (L), simply add, for each component you intend to use, the corresponding value indicated in the column "Length equivalent to m of pipe" in the table in par. 1.21, and check that the resulting sum is equal to or less than the maximum length (L max) indicated in par. 1.22. ( $L \leq L_{max}$ ).

## 1.26 CONCENTRIC VERTICAL KIT INSTALLATION

### Type C configuration, sealed chamber and fan assisted

Concentric vertical intake and exhaust kit.

This vertical terminal is connected directly to the outside of the building for air intake and flue gas exhaust.



The vertical kit with aluminium slate enables installation on terraces and roofs with a maximum slope of 45% (approx 25°) and the height between the terminal cap and half-shell (374 mm for Ø 60/100 and 260 mm for Ø 80/125) must always be observed.

### Vertical kit assembly with aluminium slate Ø60/100 (Fig. 30)

1. Install the concentric flange (2) on the flue exhaust of the appliance, positioning gasket (1) with the circular projections downwards in contact with the appliance flange.

2. Tighten the concentric flange with the screws in the kit.

Imitation aluminium slate installation:

3. Replace the slates with the aluminium sheet (4), shaping it to ensure that rainwater runs off.

4. Position the fixed half-shell (6) on the aluminium slate.

5. Insert the intake-exhaust pipe (5).

6. Fit the Ø 60/100 concentric terminal pipe with the male side (5) (smooth) into the flange (2) up to the end stop, making sure that the wall sealing plate has been fitted (3); this will ensure sealing and joining of the elements making up the kit.



When the appliance is installed in areas where very rigid temperatures can be reached, a special anti-freeze kit is available that can be installed as an alternative to the standard kit.

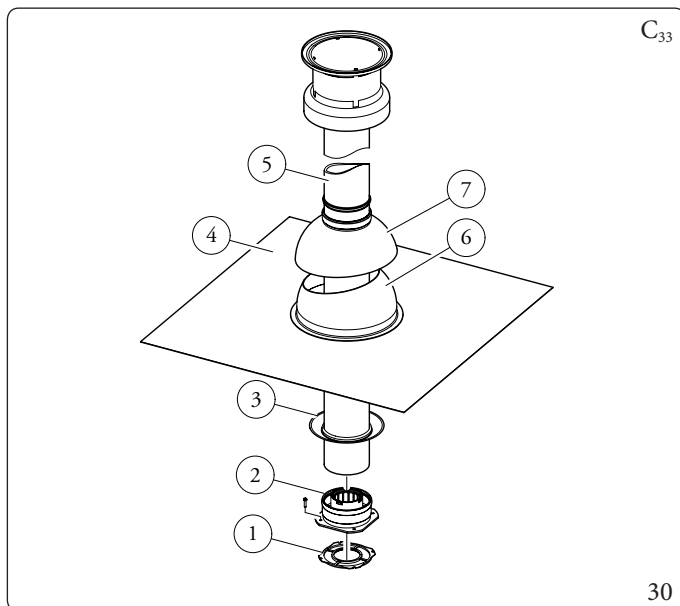

The kit includes (Fig. 30):

N°1 Gasket (1)

N°1 Female concentric flange (2)

N°1 Wall sealing plate (3)

N°1 Aluminium slate (4)

N°1 Concentric intake/exhaust pipe Ø 60/100 (5)

N°1 Fixed half-shell (6)

N°1 Mobile half-shell (7)



Extensions for vertical kit Ø 60/100 (L = Equivalent length - L max = Maximum length) (Fig. 31).



The maximum lengths ((L max) of the various flues that can be installed are given in the summary table in parag. 1.22.

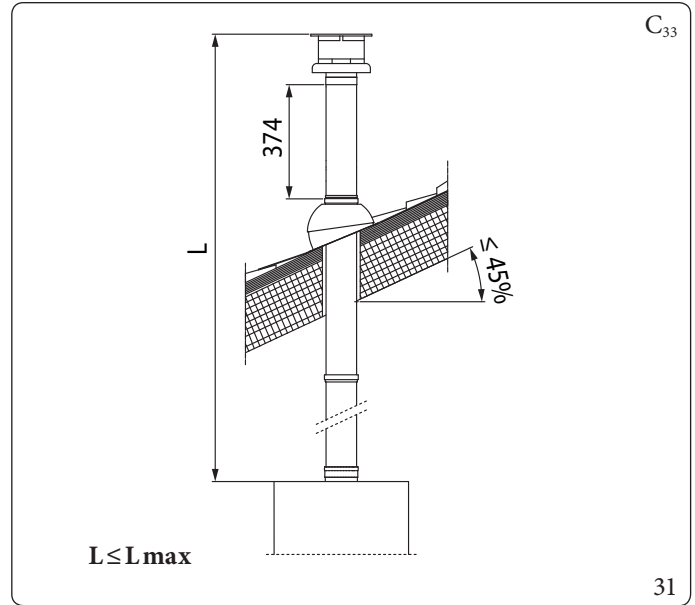

## Installation examples

Type of Duct	Minimum outlet height roof/wall (m)
	X
Concentric Ø 60/100 Vertical	0,374

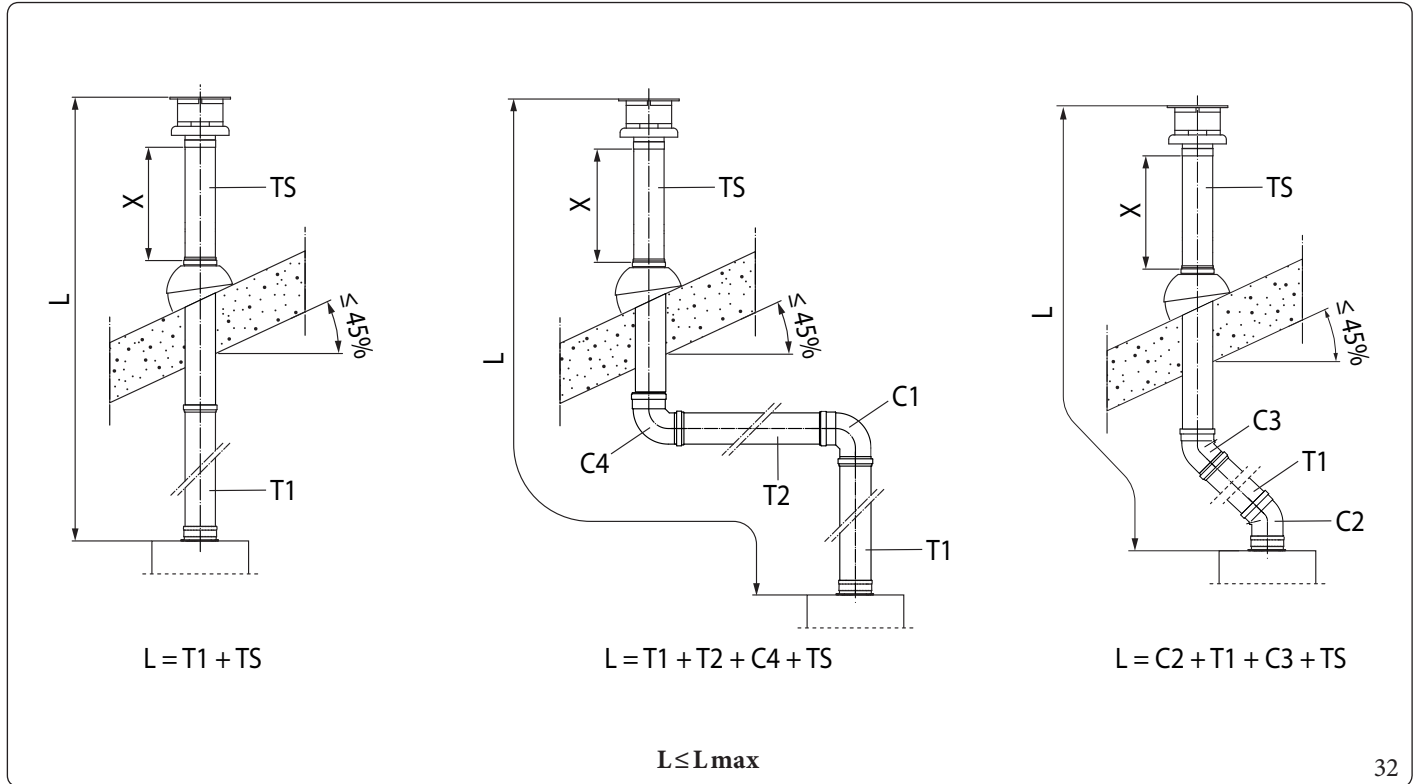

Key Fig. 32:

- |  |   |
|--|---|
| T1 - Concentric pipe Ø60/100   | C3 - Ø60/100 45° concentric elbow                 |
| C1 - 90° concentric elbow Ø60/100 (do not consider when calculating the equivalent length) | C4 - Ø60/100 90° concentric elbow                 |
| T2 - Concentric pipe Ø60/100   | TS - Concentric intake / exhaust terminal Ø60/100 |
| C2 - Ø60/100 45° concentric elbow  | L - Equivalent length                             |
|  | Lmax - Maximum length                             |



To calculate the equivalent length of the flue (L), simply add, for each component you intend to use, the corresponding value indicated in the column "Length equivalent to m of pipe" in the table in par. 1.21, and check that the resulting sum is equal to or less than the maximum length (L max) indicated in par. 1.22. ( $L \leq L_{max}$ ).



## Vertical kit assembly with aluminium slate Ø80/125 (Fig. 33)



To install the kit Ø 80/125 one must use the adapter kit (pos. 2, Fig. 33).

1. Install the concentric flange (2) on the flue exhaust of the appliance, positioning gasket (1) with the circular projections downwards in contact with the appliance flange.

Imitation aluminium slate installation:

2. Tighten the concentric flange with the screws in the kit.
3. Replace the slates with the aluminium sheet (4), shaping it to ensure that rainwater runs off.
4. Position the fixed half-shell (5) on the aluminium slate;
5. Insert the intake-exhaust terminal (7);
6. Fit the Ø 80/125 concentric terminal pipe with the male side (smooth) to the female side of the adapter (1) (with lip seals) up to the end stop, making sure that the wall sealing plate (3) has been fitted; this will ensure sealing and joining of the elements making up the kit.

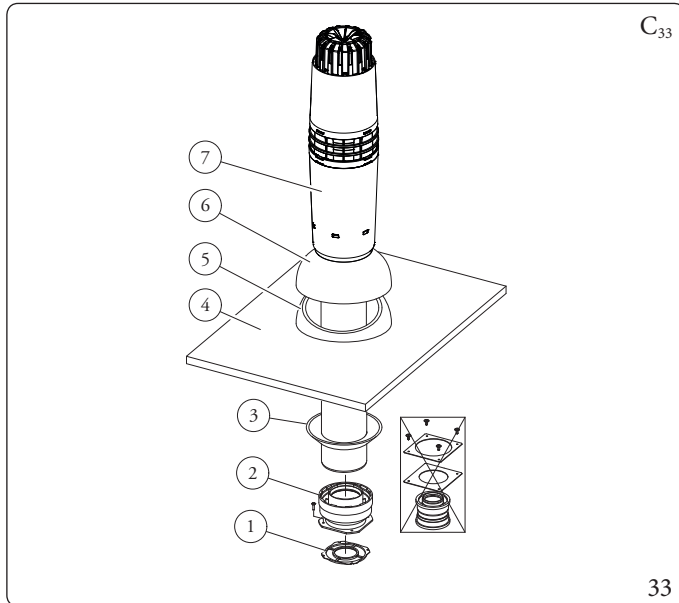

The adaptor kit includes (Fig. 33):

- N°1 Gasket (1)
- N°1 Adapter Ø 80/125 (2)

The Ø 80/125 kit includes (Fig. 33):

- N°1 Wall sealing plate (3)
  - N°1 Aluminium slate (4)
  - N°1 Fixed half-shell (5)
  - N°1 Mobile half-shell (6)
  - N°1 Concentric intake/exhaust pipe Ø 80/125 (7)
- The remaining kit components must not be used

### Extensions for vertical kit Ø 80/125 (L = Equivalent length - L max = Maximum length) (Fig. 34).



The maximum lengths ((L max) of the various flues that can be installed are given in the summary table in parag. 1.22.

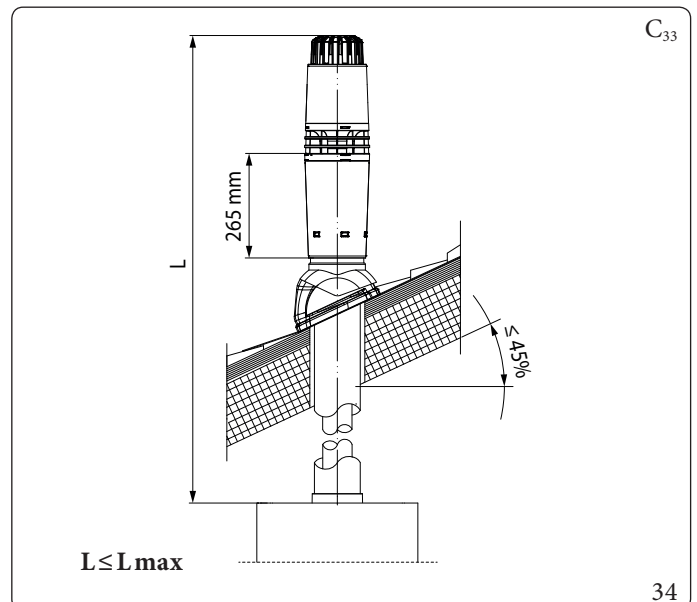

## Installation examples

Type of Duct	Minimum outlet height roof/wall (m)
	X
Concentric Ø 80/125 Vertical	0,26

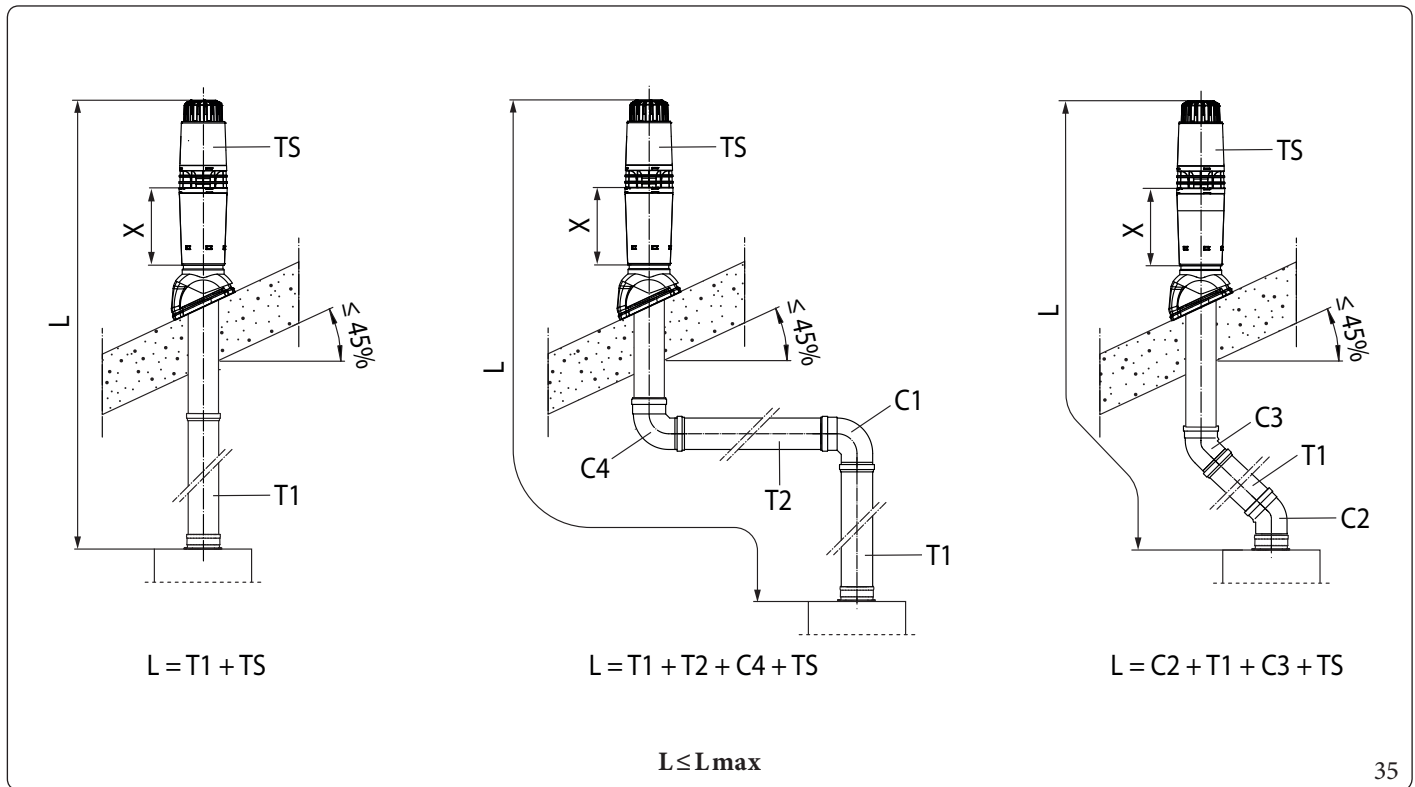

### Key Fig. 35:

- |    |   |      |  |
|----|---|------|--|
| T1 | - Concentric pipe Ø80/125   | C3   | - Ø80/125 45° concentric elbow                 |
| C1 | - 90° concentric elbow Ø80/125 (do not consider when calculating the equivalent length) | C3   | - Ø80/125 90° concentric elbow                 |
| T2 | - Concentric pipe Ø80/125   | TS   | - Concentric intake / exhaust terminal Ø80/125 |
| C2 | - Ø80/125 45° concentric elbow  | L    | - Equivalent length                            |
|    |   | Lmax | - Maximum length                               |



To calculate the equivalent length of the flue (L), simply add, for each component you intend to use, the corresponding value indicated in the column "Length equivalent to m of pipe" in the table in par. 1.21, and check that the resulting sum is equal to or less than the maximum length (L max) indicated in par. 1.22. ( $L \leq L_{max}$ ).



## 1.27 INSTALLATION OF VERTICAL TERMINALS Ø 80

### Configuration type B, open chamber and fan assisted

#### Mounting the vertical kit Ø 80 (Fig. 36)

1. Install the Ø 80 terminal (2) on the central hole on the appliance up to the end stop, making sure that the wall sealing plate (1) has been fitted. This will ensure the sealing efficiency of the kit components.

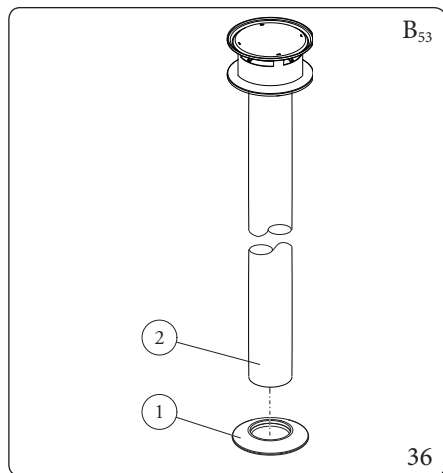

The Kit includes (Fig. 36):  
 N°1 Wall sealing plate (1)  
 N°1 Exhaust terminal Ø 80 (2)

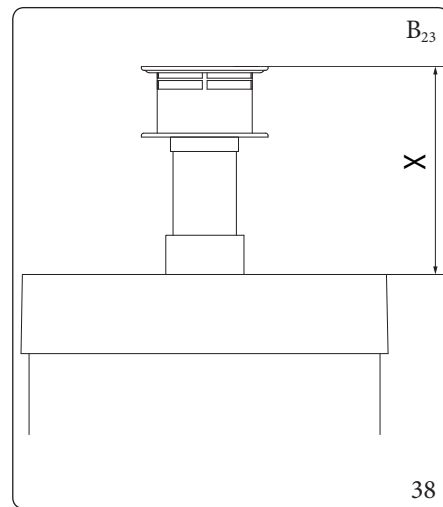
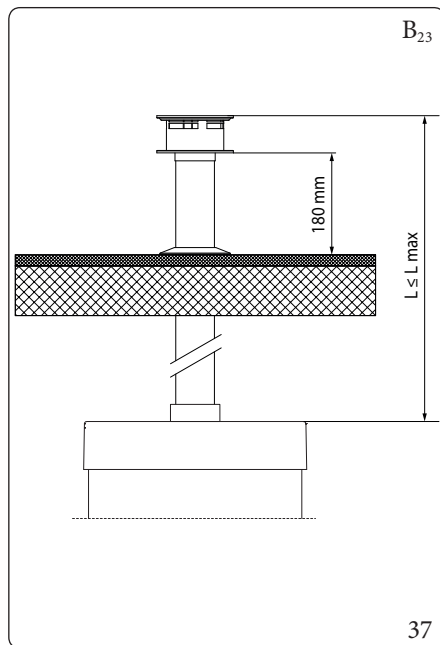

Key (Fig. 38):  
 X = 250

Maximum length ( $L = \text{Length} - L_{\text{max}} = \text{Maximum length}$ ) (Fig. 37).

Using the Ø 80 vertical terminal for direct discharge of the combustion products, the terminal must be shortened (see quotas fig. 138). The wall sealing plate (1) must also be inserted in this case going up to stop on the appliance cover.

**i** The maximum lengths ( $L_{\text{max}}$ ) of the various flues that can be installed are given in the summary table in parag. 1.22.

#### Ø80 vertical kit installation (in stainless steel) (Fig. 39)

1. Install the Ø 80 terminal (1) on the central hole on the appliance up to the end stop, ensuring the sealing efficiency of the kit components.

The 80 Ø steel terminal is used to install the boiler outdoors with a direct exhaust. The terminal cannot be shortened and once it is installed it will extend out by 1000 mm (Fig. 40).

The Kit includes (Fig. 39):  
 N°1 Steel exhaust terminal Ø 80 (1)

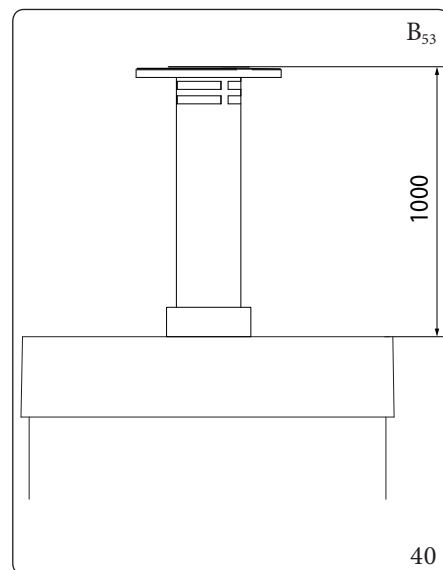
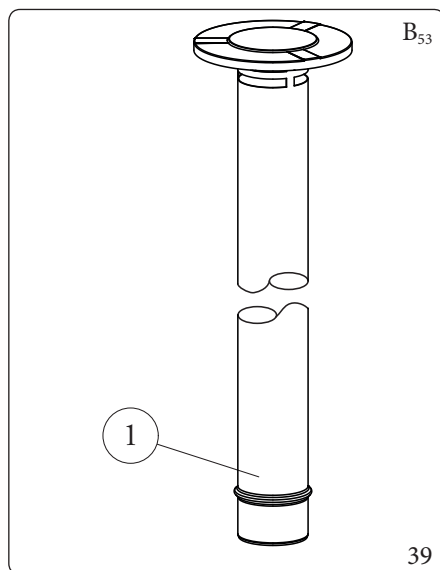



## 1.28 SEPARATOR KIT INSTALLATION

### Type C configuration, sealed chamber and fan assisted separator kit Ø 80/80

This kit allows air to come in from outside the building and the exhaust to exit from the chimney, flue or intubated duct through divided flue exhaust and air intake pipes.

Combustion products are expelled from pipe (S) (in plastic, so as to resist acid condensate).

Air is taken in through duct (A) for combustion (this is also in plastic).

Both ducts can be routed in any direction.

#### Assembly of separator kit Ø 80/80 (Fig. 41):

1. Install the flange (4) on the central hole of the appliance, positioning gasket (1) with the circular projections downwards in contact with the appliance flange.
2. Tighten with the hexagonal head and flat point screws provided in the kit.
3. Replace the flat flange present in the lateral hole with respect to the central one (according to needs) with the flange (3), positioning the gasket (2) in between.
4. Tighten with the supplied self-tapping screws with drill bit.
5. Fit the bends with male side (smooth) (5) in the female side of the flanges (3 and 4).
6. Fit the intake terminal (6) with the male side (smooth) in the female side of the bend (5) up to the end stop, ensuring that the internal and external wall sealing plates are fitted
7. Fit the exhaust pipe (9) with the male end (smooth) to the female end of the bend (5) up to the end stop; making sure that the internal wall sealing plate has been fitted, this will ensure sealing and joining of the elements making up the kit.

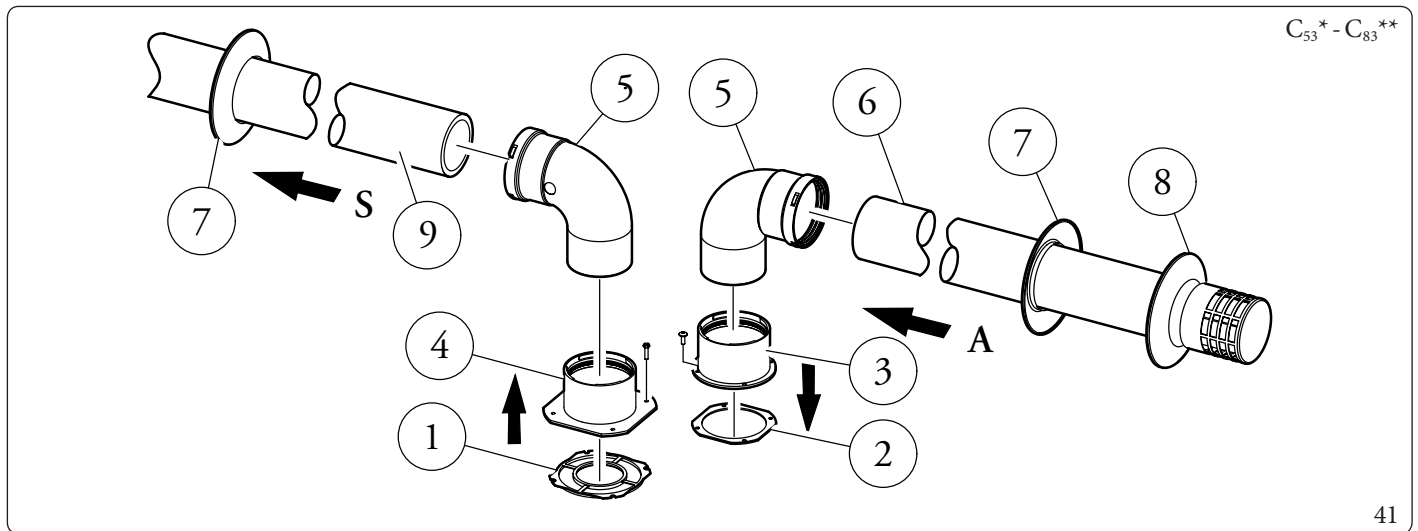

The kit includes (Fig. 41):

- N°1 Exhaust gasket (1)
- N°1 Flange gasket (2)
- N°1 Female intake flange (3)
- N°1 Female exhaust flange (4)
- N°2 Ø 80 90° bend (5)
- N°1 Intake terminal Ø 80 (6)
- N°2 Internal wall sealing plates (7)
- N°1 External wall sealing plate (8)
- N°1 Exhaust pipe Ø 80 (9)

\* to complete C<sub>53</sub> configuration, also provide for a "green range" roof discharge terminal. The configuration on walls opposite the building is not allowed.

\*\* configuration C<sub>8</sub> envisages connection to flues working with natural draught.



For technical data concerning the C<sub>8</sub> configuration, please refer to the table in par. 5.2.



**Installation clearances (Fig. 42)**

The minimum installation clearance measurements of the Ø 80/80 separator terminal kit have been stated in some limit conditions.

\* Configuration C<sub>4</sub> envisages connection to flues working with natural draught.



For technical data concerning the C<sub>4</sub> configuration, please refer to the table in par. 5.2.

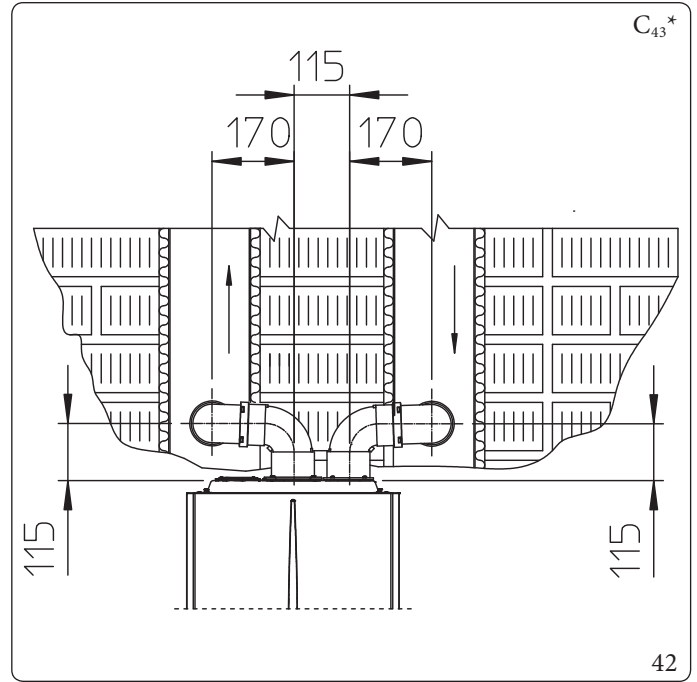

**Extensions for separator kit Ø 80/80 (L = Equivalent length - L max = Maximum length).**



To aid in the removal of possible condensate forming in the exhaust pipe, tilt the pipes towards the appliance with a minimum slope of 5% (Fig. 43).

Please note the type of installation C<sub>43</sub> must be done with a natural draught flue.

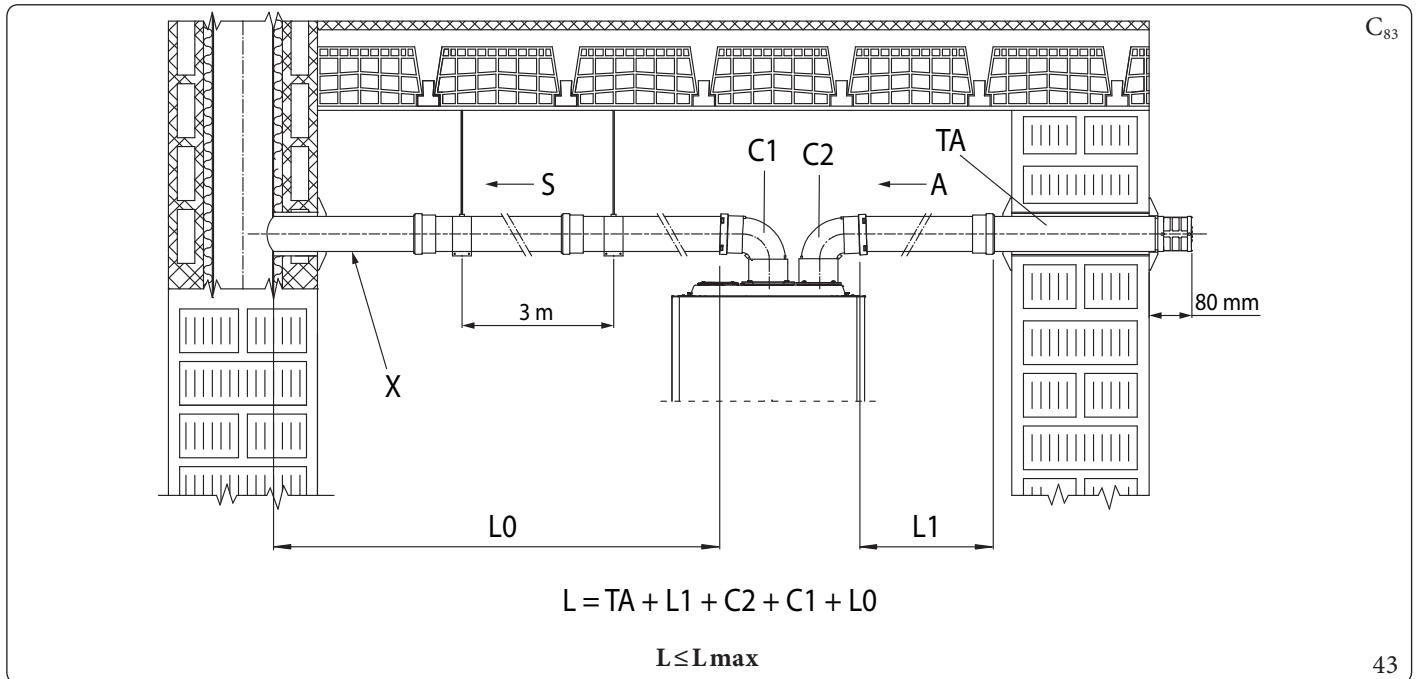

Key (Fig. 43):

- A - Intake
- X - Minimum slope 5%
- S - Exhaust
- L - Equivalent length

- L max - Maximum length
- TA - Intake terminal Ø80/80
- C1 - Ø80/80 90° elbow
- C2 - Ø80/80 90° elbow



The maximum lengths ((L max) of the various flues that can be installed are given in the summary table in parag. 1.22.

## Installation examples

Type of Duct	Minimum outlet height roof/wall (m)
	X
Split Ø 80/80 Horizontal (with intake and exhaust bend)	0,08
Split Ø 80/80 Vertical (without bends)	-

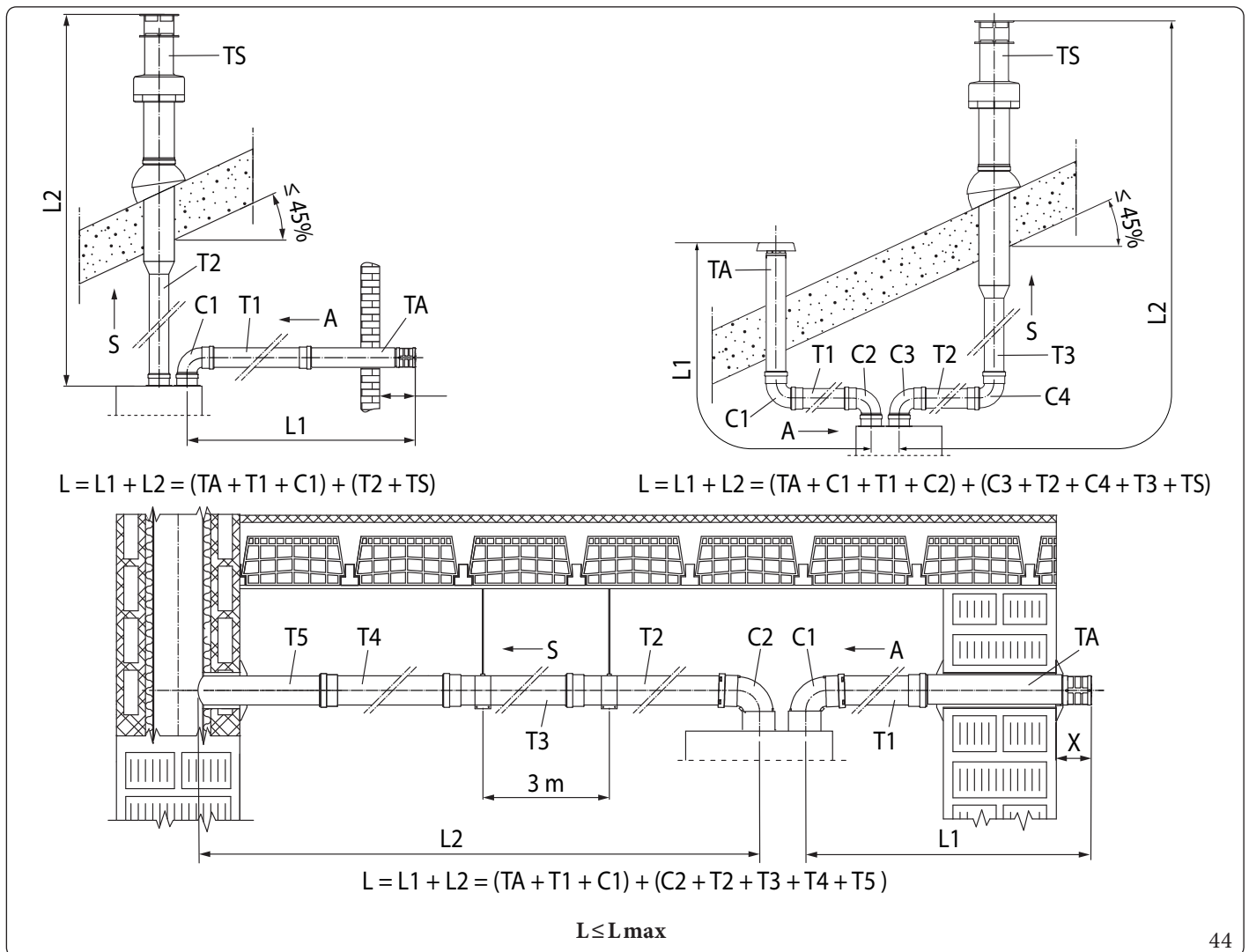

Key Fig. 44:

- TA - Intake terminal Ø80
- T1 - Pipe Ø80
- T2 - Pipe Ø80
- T3 - Pipe Ø80
- T4 - Pipe Ø80
- T5 - Pipe Ø80

- C1 - Ø80 90° elbow
- C2 - Ø80 90° elbow
- C3 - Ø80 90° elbow
- C4 - Ø80 90° elbow
- L - Equivalent length
- Lmax - Maximum length



To calculate the equivalent length of the flue (L), simply add, for each component you intend to use, the corresponding value indicated in the column "Length equivalent to m of pipe" in the table in par. 1.21, and check that the resulting sum is equal to or less than the maximum length (L max) indicated in par. 1.22. ( $L \leq L_{max}$ ).



## 1.29 ADAPTOR KIT INSTALLATION C<sub>9</sub>

This kit allows an Immergas appliance to be installed in C<sub>93</sub> configuration, with combustion air intake directly from the shaft where the flue gas exhaust is, obtained by means of a ducting system.

### System composition

The system must be combined with the following components (sold separately) to be functional and complete:

- kit C<sub>93</sub> " Ø 100 or Ø 125 version;
- ducting kit rigid Ø 60 and Ø 80 and flexible Ø 50 and Ø 80;
- flue exhaust kit Ø 60/100 or Ø 80/125 configured according to the installation and type of appliance.

### Mounting adapter kit C<sub>9</sub> (Fig. 45)



(Version Ø 125 only) before assembly check the gaskets are in the right position.

If component lubrication is not sufficient (applied previously by the manufacturer), remove the residual lubricant using a dry cloth, then grease the parts with the supplied lubricant in order to ease the push-fitting operations.



To aid in the removal of possible condensate forming in the exhaust pipe, tilt the pipes towards the appliance with a minimum slope of 5% (Fig. 43).

1. Mount the components of kit C<sub>9</sub> on the door (A) of the ducting system (Fig.45).
2. (Version Ø 125 only) mount the flanged adaptor (11) interposing the concentric gasket (10) on the appliance, fitting it with the screws (12).
3. Mount the ducting system as described in the relative instructions sheet.
4. Calculate the distances between the appliance drain and the bend of the ducting system.
5. Prepare the appliance flue system, making sure that the internal pipe of the concentric kit is fitted up to the end stop in the ducting system curve (Quota "X" Fig. 47), whereas the external pipe must reach the end stop of the adaptor (1).
6. Mount the cover (A) complete with adaptor (1) and caps (6) on the wall.
7. Assemble the flue system to the ducting system.

Once all components have been assembled properly, the exhaust fumes will be expelled via the ducting system; the combustion air for normal boiler operation will be aspirated directly by the shaft (Fig. 47).

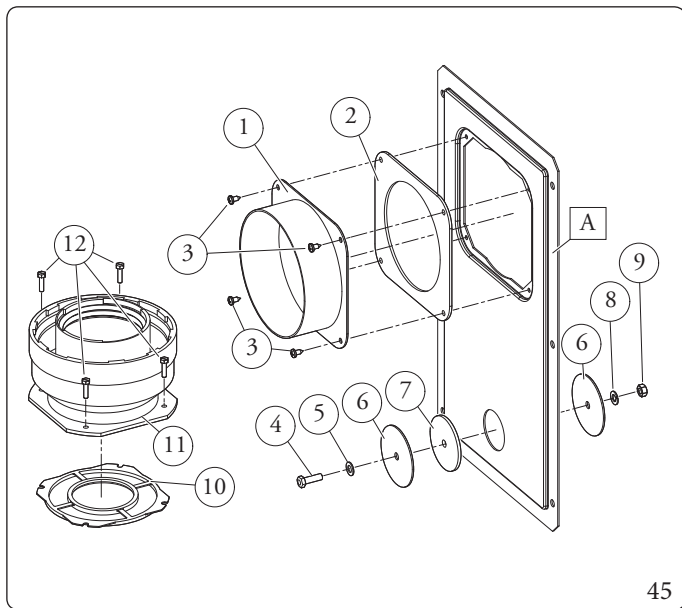

The adapter kit includes (Fig. 45):

- N°1 Door adaptor Ø 100 or Ø 125 (1)
- N°1 Door gasket made of neoprene (2)
- N°4 Screws 4.2 x 9 AF (3)
- N°1 Hex headed screw M6 x 20 (4)
- N°1 Flat nylon washer M6 (5)
- N°2 Door hole closure metal-sheet plate plug (6)
- N°1 Plug gasket made of neoprene (7)
- N°1 Toothed washer M6 (8)
- N°1 Nut M6 (9)
- N°1 (Ø 80/125 kit) Concentric gasket Ø 60/100 (10)
- N°1 (Ø 80/125 kit) Flanged adaptor Ø 80/125 (11)
- N°4 (Ø 80/125 kit) M4 hex headed screws x 16 slotted screwdriver (12)
- N°1 (Ø 80/125 kit) Lubricant bag

Supplied separately (Fig. 45):

- N°1 Ducting kit door (A)

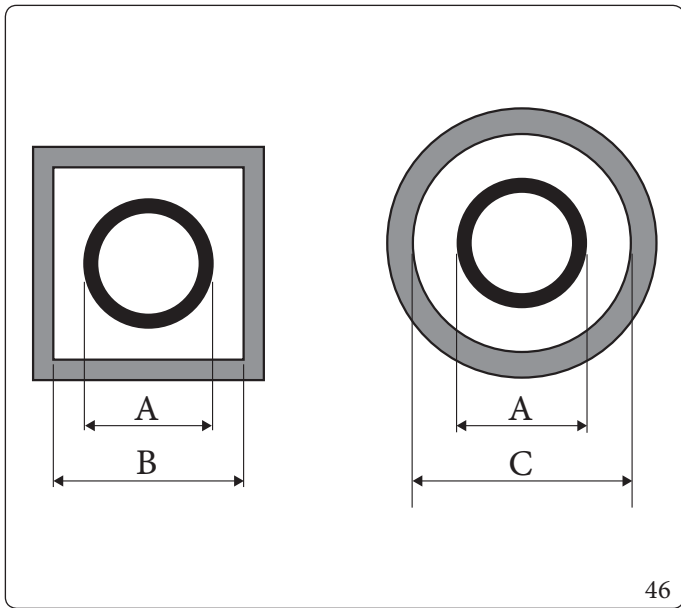

Ducting	ADAPTOR (A) mm	SHAFT (B) mm	SHAFT (C) mm
Ø60 Rigid	66	106	126
Ø50 Flexible	66	106	126
Ø80 Rigid	86	126	146
Ø80 Flexible	103	143	163

### Technical data

The dimensions of the shafts must ensure a minimum gap between the outer wall of the smoke duct and the inner wall of the shaft: 30 mm for circular section shafts and 20 mm in the event of a square section shaft (Fig. 46).

Maximum 2 changes of direction are allowed on the vertical section of the flue system with a maximum clearance angle of 30° with respect to the vertical.

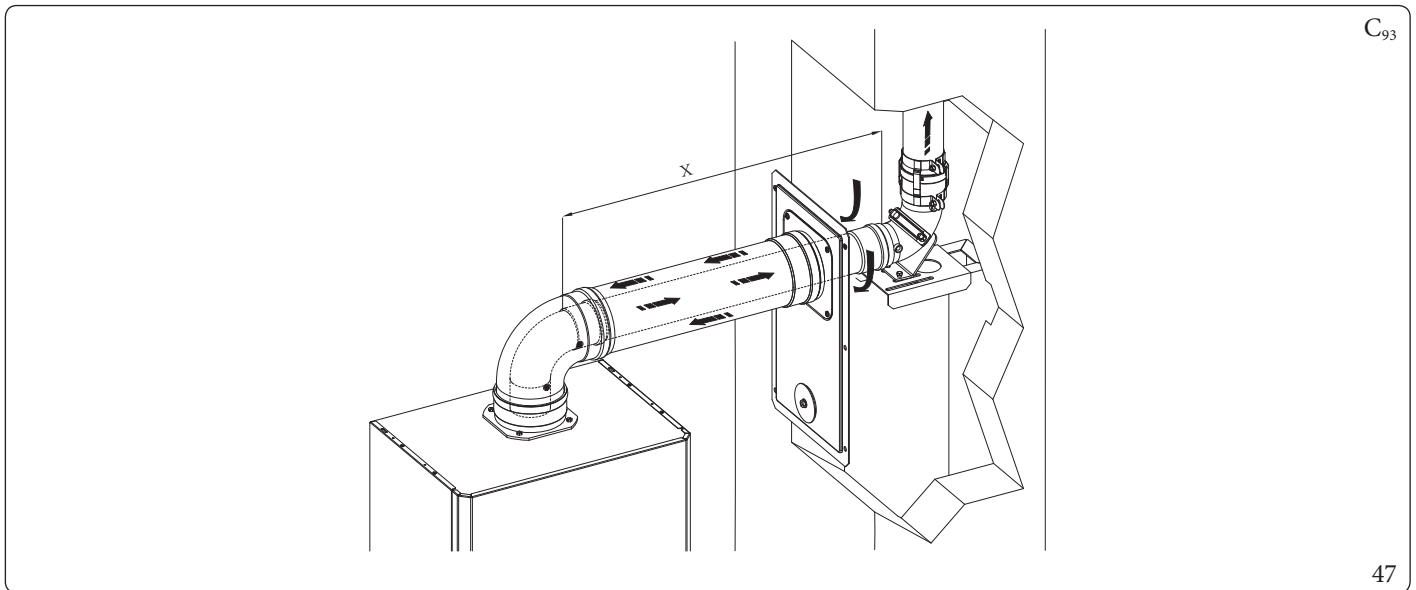

The maximum lengths ((L max) of the various flues that can be installed are given in the summary table in parag. 1.22.



### 1.30 DUCTING OF FLUES OR TECHNICAL SLOTS

Ducting is an operation through which, via the introduction of one or more relevant pipes, one achieves a system for the evacuation of the combustion products of a gas appliance, made up from the coupling of an existing or new ducting pipe with a chimney, flue or technical slot (also in new buildings) (Fig. 48).

Ducting requires ducts declared to be suitable for the purpose by the manufacturer, following the installation and user instructions, provided by the manufacturer and the requirements of the regulations in force.

#### Immergas ducting systems



The Ø 60 rigid, Ø 50 and Ø 80 flexible and Ø80 rigid "Green Range" ducting systems must only be used for domestic use and with Immergas condensing boilers.

In any case, ducting operations must respect the provisions contained in the standard and in current technical regulations; in particular, the declaration of conformity must be compiled at the end of work and on commissioning of the ducted system.

The instructions in the project or technical report must likewise be followed, in cases provided for by the standard and current technical regulations.

To guarantee reliability and operation over time of the ducting system, make sure:

- it is used in average atmospheric and environmental conditions, according to current regulations (absence of combustion products, dusts or gases that can alter the normal thermophysical or chemical conditions; existence of temperatures coming within the standard range of daily variation, etc.).
- Installation and maintenance must be performed according to the indications supplied by the manufacturer included with the "green range" ducting system chosen and in compliance with the regulations in force.
- To guarantee long-time reliability and functionality of the ducting system, the maximum length specified by the manufacturer (Par. 1.22) must be complied with.

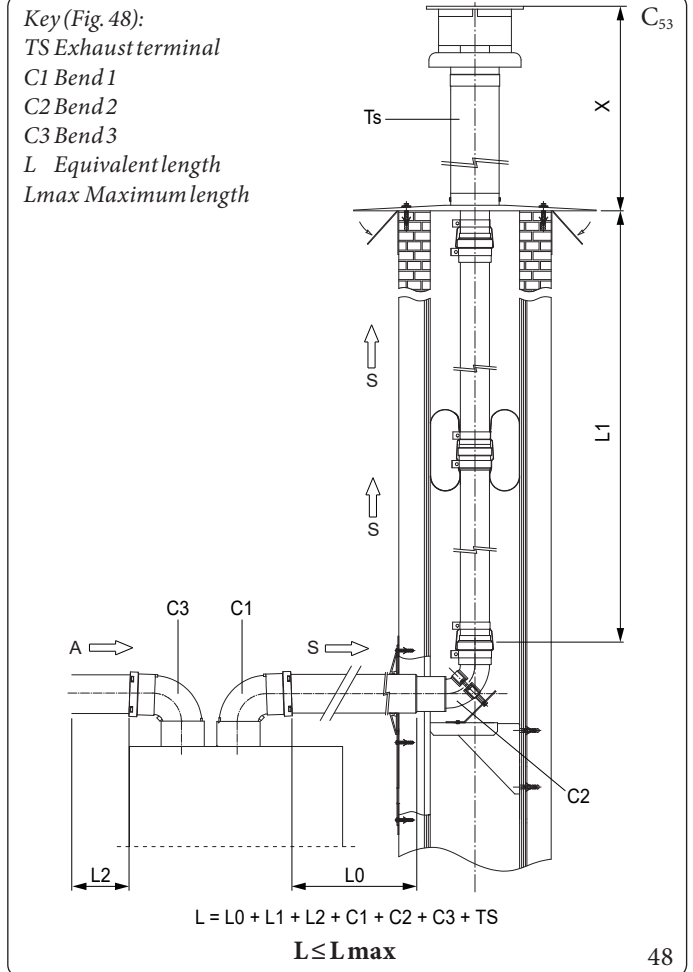

In flexible and rigid ducting configurations  $C_{53}$ , the maximum length ( $L_{max}$ ) does not include the 3 elbows and the exhaust terminal. They must therefore be considered when calculating the equivalent length ( $L$ ).



The maximum lengths ( $L_{max}$ ) of the various flues that can be installed are given in the summary table in parag. 1.22.

## 1.31 CONFIGURATION FOR C<sub>6</sub> FLUE INSTALLATION



Appliance designed to be connected to a commercial exhaust/intake system.

### Victrix24HY

Gas type		G20	G31
Flue temperature at maximum output	°C	70	69
Flue gas mass at maximum power	kg/h	38	37
Flue temperature at minimum output	°C	64	69
Flue gas mass at minimum power	kg/h	8	7
CO <sub>2</sub> at Q. max.	%	9,7 (9,5 ÷ 10,2)	11,4 (11,1 ÷ 11,5)
CO <sub>2</sub> a Q. minimum	%	8,8 (8,5 ÷ 9,0)	10,6 (10,5 ÷ 10,9)
Maximum head available at maximum power (maximum resistance value of the commercial flue system)	Pa	154	
Maximum head available at minimum power	Pa	4	
Maximum flue gas circuit temperature	°C	120	

### Victrix32HY

Gas type		G20	G31
Flue temperature at maximum output	°C	72	72
Flue gas mass at maximum power	kg/h	45	44
Flue temperature at minimum output	°C	62	62
Flue gas mass at minimum power	kg/h	9	9
CO <sub>2</sub> at Q. max.	%	9,5 (9,3 ÷ 9,7)	11,2 (10,8 ÷ 11,4)
CO <sub>2</sub> a Q. minimum	%	8,6 (8,3 ÷ 8,8)	10,0 (9,8 ÷ 10,4)
Maximum head available at maximum power (maximum resistance value of the commercial flue system)	Pa	204	204
Maximum head available at minimum power	Pa	6	
Maximum flue gas circuit temperature	°C	120	



- Ducts must withstand condensation (only for condensing models);
- Air intake ducts must withstand working air temperatures of up to 60°C;
- The maximum permissible percentage of flue gas recirculation in windy conditions is 10%;
- Suction and exhaust pipes cannot be installed on opposing walls;
- With flues in configuration C<sub>6</sub> discharge into pressurised flues is not permitted.

INSTALLER

USER

CONTROL PANEL

MAINTENANCE TECHNICIAN

TECHNICAL DATA



### 1.32 CONFIGURATION TYPE B, OPEN CHAMBER AND FAN ASSISTED FOR INDOORS

The appliance can be installed inside buildings in B<sub>23</sub> or B<sub>53</sub> mode; in this case, all technical rules and national and local regulations in force, must be complied with.

For installation the cover kit must be used, referred to in Parag. 1.23.

### 1.33 FLUE EXHAUST TO FLUE/CHIMNEY.

Flue exhaust does not necessarily have to be connected to a branched type traditional flue for type B appliances with natural draught (CCR).

The flue exhaust, for boiler clots installed in C configuration, can be connected to a single flue or to a multiple flue.

For B<sub>23</sub> configurations, exhaust is only allowed into individual chimney or directly into the external atmosphere via a relevant terminal, unless otherwise provided by local regulations.

The multiple flues must also only be connected to type C appliances of the same type (condensation), having nominal heat inputs that do not differ by more than 30% less with respect to the maximum that can be attached and powered by the same fuel.

The thermo-fluid dynamic features (flue flow rate, % of carbon dioxide, % humidity etc.) of the appliances attached to the same multiple flues, must not differ by more than 10% with respect to the average appliance attached.

Multiple flues must be specially designed according to the calculation method and requirements of the standards (such as UNI 13384), by professionally qualified technical staff.

Chimney or flue sections for connection of the flue exhaust pipe must comply with requisites of technical standards in force.

It is possible to replace a type C conventional device with one provided with condensation, connected to multiple flues, only if the derogation conditions established by the regulations in force have been met.



### 1.34 FLUES, CHIMNEYS AND CHIMNEY CAPS.

The flues, chimneys and chimney caps for the evacuation of combustion products must be in compliance with applicable standards.

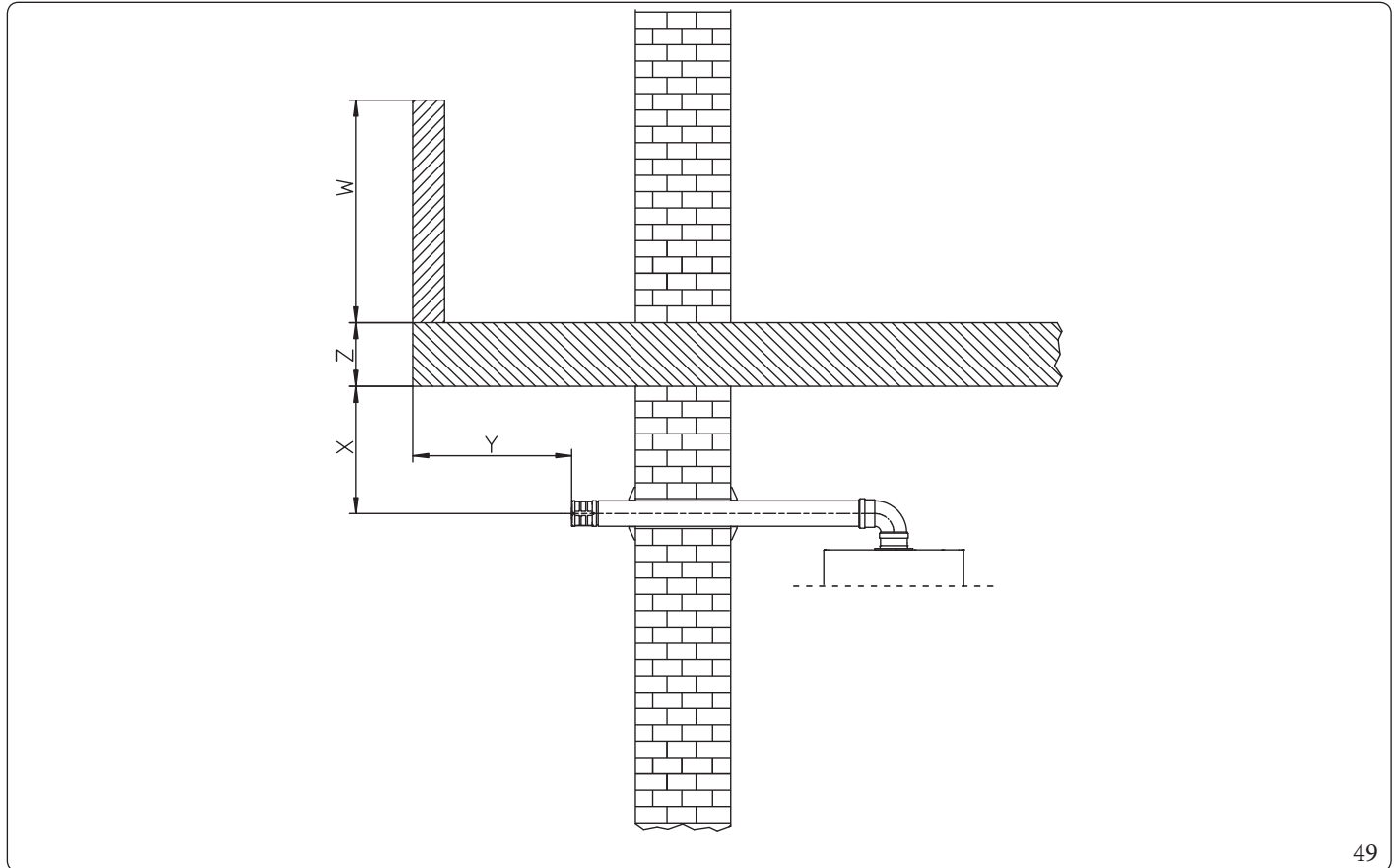

49

#### Positioning the wall flue exhaust terminals.

The wall flue exhaust terminals must:

- be installed on external perimeter walls of the building (Fig. 49);
- be positioned according to the minimum distances specified in current technical standards.

#### Combustion products exhaust of natural draught or fan assisted appliances in open-top closed environments.

In spaces closed on all sides with open tops (ventilation pits, courtyards etc.), direct combustion product exhaust is allowed for natural draught or fan assisted gas appliances with a heat input range from 4 to 35 kW, provided the conditions as per the current technical standards are respected.

INSTALLER

USER

CONTROL PANEL

MAINTENANCE TECHNICIAN

TECHNICAL DATA



## 1.35 WATER TREATMENT PLANT FILLING

The technical standard in force requires washing and treatment of the system water of the water and DHW thermal system, following the indicated methods and provisions of local standards in force.

The parameters that influence the duration and proper operation of the heat exchanger are the water's PH, total hardness, conductivity, and oxygen, together with the system's processing residues (any welding residues), any oil present and corrosion products that can, in turn, cause damage to the heat exchanger.

In order to prevent this from happening, you are recommended to:

- Before installation on new systems as well as old ones, clean the system with clean water to eliminate solid residues.
- clean the system with a chemical treatment:
  - clean the new system with a suitable cleaning device (for example Sentinel X300, Fernox Cleaner F3 or Jenaqua 300) combined with thorough washing;
  - clean the old system with a suitable cleaning device (for example Sentinel X400 or X800, Fernox Cleaner F3 or Jenaqua 400) combined with thorough washing;
- Check the maximum total hardness and amount of filling water with reference to the graph (Fig. 50), if the contents and hardness of the water are below the indicated curve, no specific treatment is required; otherwise, to limit the content of calcium carbonate, you must provide for water-filling treatment.
- If it is necessary to provide for water treatment, it should be done through complete desalination of the filling water. As opposed to the complete softening process, desalinating the water completely not only removes hardening agents (Ca, Mg), but also eliminates all other minerals to reduce water-filling conductivity up to 10 microsiemens/cm. Given its low conductivity, desalinated water does not only prevent the formation of lime scale, but also serves as protection against corrosion.
- Insert a suitable inhibitor / passivator (for example Sentinel X100, Fernox Protector F1, or Jenaqua 100); if required, also insert appropriate antifreeze (such as for example Sentinel X500, Fernox Alphi 11 or Jenaqua 500).
- Check electrical conduction of the water, which should be higher than 2000  $\mu\text{s}/\text{cm}$  in the case of treated water and lower than 600  $\mu\text{s}/\text{cm}$  in the case of non-treated water.
- To prevent corrosion, the water system's PH should be between 7.5 and 9.5.
- Check the maximum content of chlorides, which should be less than 250 mg/l.



For quantities and methods of use of water-treatment products, refer to the instructions provided by their manufacturer.

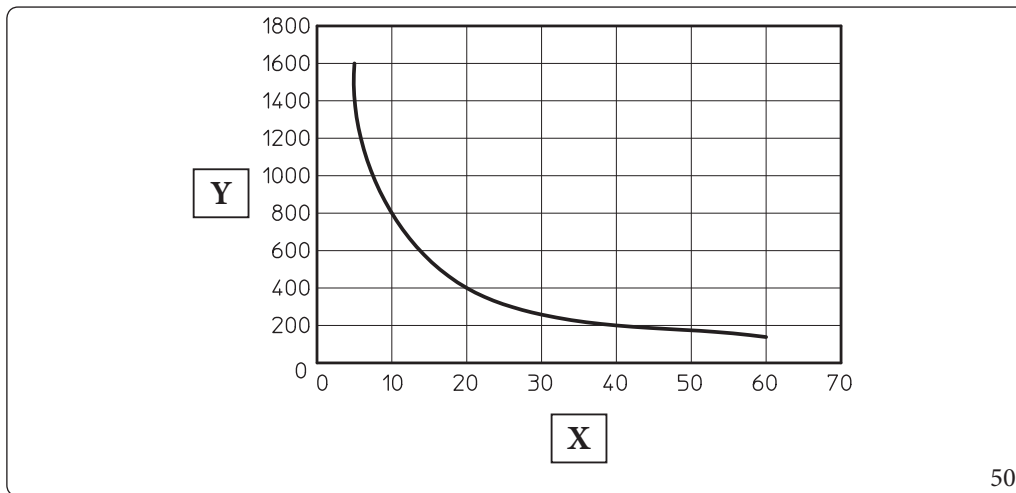

Key (Fig. 50):

- X - Total water hardness  
°F
- Y - Litres of system water



The graph refers to the entire life cycle of the system. Therefore, also consider scheduled and unscheduled maintenance, which involves emptying and filling the said system.

### 1.36 SYSTEM FILLING

Once the appliance is connected, proceed with system filling via the filling valve (Part. 26 Fig. 54).

Filling is performed at low speed to ensure release of air bubbles in the water via the appliance and central heating system vents.

The appliance has a built-in automatic vent valve on the pump.

Then open the radiator vent valves.

Close radiator vent valves when only water escapes from them.

The filling valve must be closed when the appliance pressure gauge indicates approximately 1.2 bar cold.



During these operations, enable the automatic vent functions on the appliance (Parag. 3.11);

### 1.37 FILLING THE CONDENSATE DRAIN TRAP



**When the appliance is switched on for the first time, combustion products come out of the condensate drain. After a few minutes of operation, check that combustion flue gases are no longer coming out of the condensate drain; this means that the drain trap has filled to a correct condensate height that the flue gases cannot pass through.**

### 1.38 GAS SYSTEM START-UP

To start up the system, refer to the technical standards in force.

This divides the systems and, therefore, the commissioning operations, into three categories: new systems, modified systems, reactivated systems.

In particular, for new gas systems:

- open windows and doors;
- avoid presence of sparks or naked flames;
- bleed all air from pipelines;
- ensure the internal system is properly sealed according to the specifications set forth by technical regulations in force.



### 1.39 APPLIANCE START-UP (IGNITION)

To commission the appliance (the operations listed below must only be performed by qualified personnel and in the presence of staff only):

1. check that the internal system is properly sealed according to the specifications set forth by regulations in force;
2. Make sure that the type of gas used corresponds to boiler settings;
3. Check connection to a 230V~50Hz power mains, correct L-N polarity and the earthing connection;
4. Switch the appliance on and check correct ignition;
5. Make sure that the gas flow rate and relevant pressure values comply with those given in the manual (Par.5.1);
6. ensure that the safety device intervenes in the event of gas supply failure and check the relative intervention time;
7. Check the activation of the main switch located upstream of the appliance and in the appliance.
8. Check that the intake / exhaust terminals (if fitted) are not blocked;
9. **Check that the drain trap is full and that it prevents any passage of flue gas into the room;**
10. Carry out the flue test;



Even if just one single safety check provides a negative result, do not commission the system.

## 1.40 UPM4 CIRCULATION PUMP

The appliances are supplied with a variable speed circulator pump.

In the central heating mode, the following operating modes are available and can be selected in the "P.C.B. programming" menu (Parag. 3.6).



The  $\Delta T$  can be controlled compatibly with the characteristics of the central heating system and of the appliance.

- **Proportional head (A4=0):** the circulator speed varies according to the power emitted by the burner, the greater the power the greater the speed.
- **$\Delta T$  Constant (A4= 5 - 25 K):** the pump speed varies to maintain the  $\Delta T$  constant between the system flow and return according to set value K (A4= 15 Default).
- **Fixed:** by setting parameters "A2" and "A3" at the same value (6 - 9), the pump operates at constant speed. For the boiler to work properly, it is not allowed to drop below the minimum value indicated above.



In domestic hot water mode, the circulator pump always runs at full speed.

### Pump symbols (Fig. 51):

With the pump powered and the pwm control signal connected and operating (pump ON or in stand-by), the symbol 2 flashes green ( ).

If the symbol 2 turns steady green ( ), the pump detects no command on the pwm signal and always runs at maximum speed.

If the pump detects an alarm, symbol 1 lights up red ( ). This can mean that there is one of the following faults:

- Low power supply voltage.
- Rotor seized (Cautiously turn the screw in the centre of the head to manually release the motor shaft).
- Electrical error.



These anomalies will be signalled on the boiler display as errors "60" or "61" as indicated in par. 3.17.

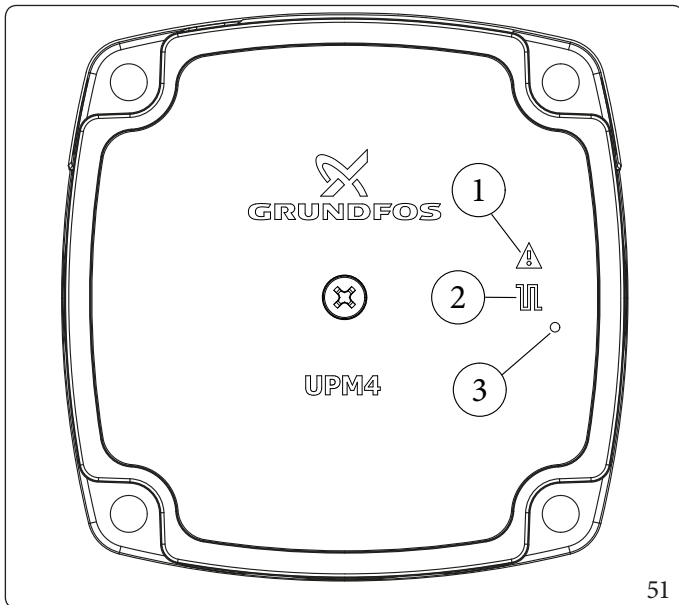

Key (Fig. 51):

- 1 - Alarm signal (Red)
- 2 - Functioning status signal (Steady green/Flashing green)
- 3 - Led (Not used on this model)

### Pump release.

If after a long period of inactivity, the circulator is blocked, adjust the screw in the centre of the head in order to manually release the motor shaft.

Take great care during this operation to avoid damage to the motor.

### Bypass Regulation (Ref. 23 Fig. 54):

The appliance leaves the factory with the bypass closed.

This is the only configuration that guarantees proper operation of the product and should therefore not be changed.



Indoor Unit (Victrix24HY) + Outdoor Unit (Audax.DK4) available head

INSTALLER

USER

CONTROL PANEL

MAINTENANCE TECHNICIAN

TECHNICAL DATA

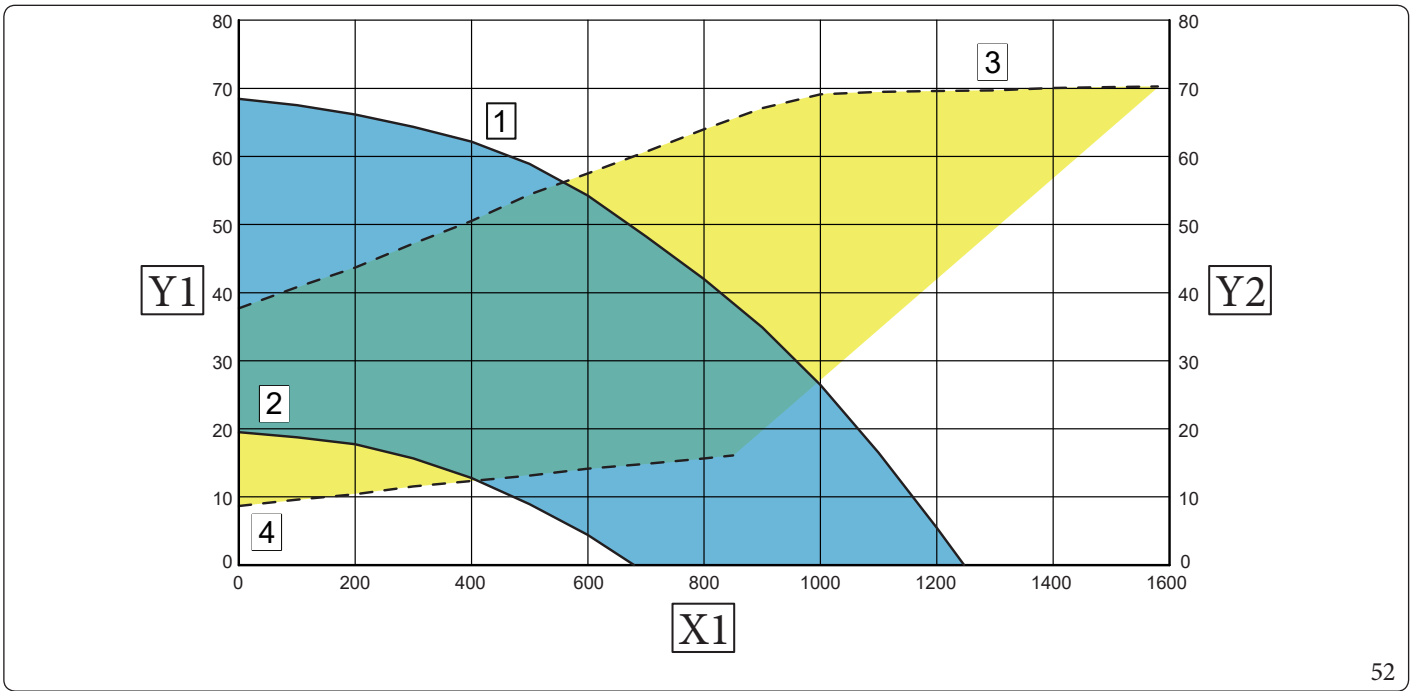

Key (Fig. 52):

- 1 = Head available to the system at speed 100% with by-pass closed
  - 2 = Head available to the system at Speed 40% with by-pass closed
  - 3 = Circulator power input at Speed 100% with closed by-pass
  - 4 = Circulator power input at Speed 40% with closed by-pass
  - Area between curves 1 and 2 = Available system head with bypass closed
  - Area between curves 3 and 4 = Circulator absorbed power with bypass closed
- X1 = Flow rate (l/h)
  - Y1 = Head (kPa)
  - Y2 = Power absorbed by pump (W)



## Indoor Unit (Victrix 32HY) + Outdoor Unit (Audax.DK4) available head

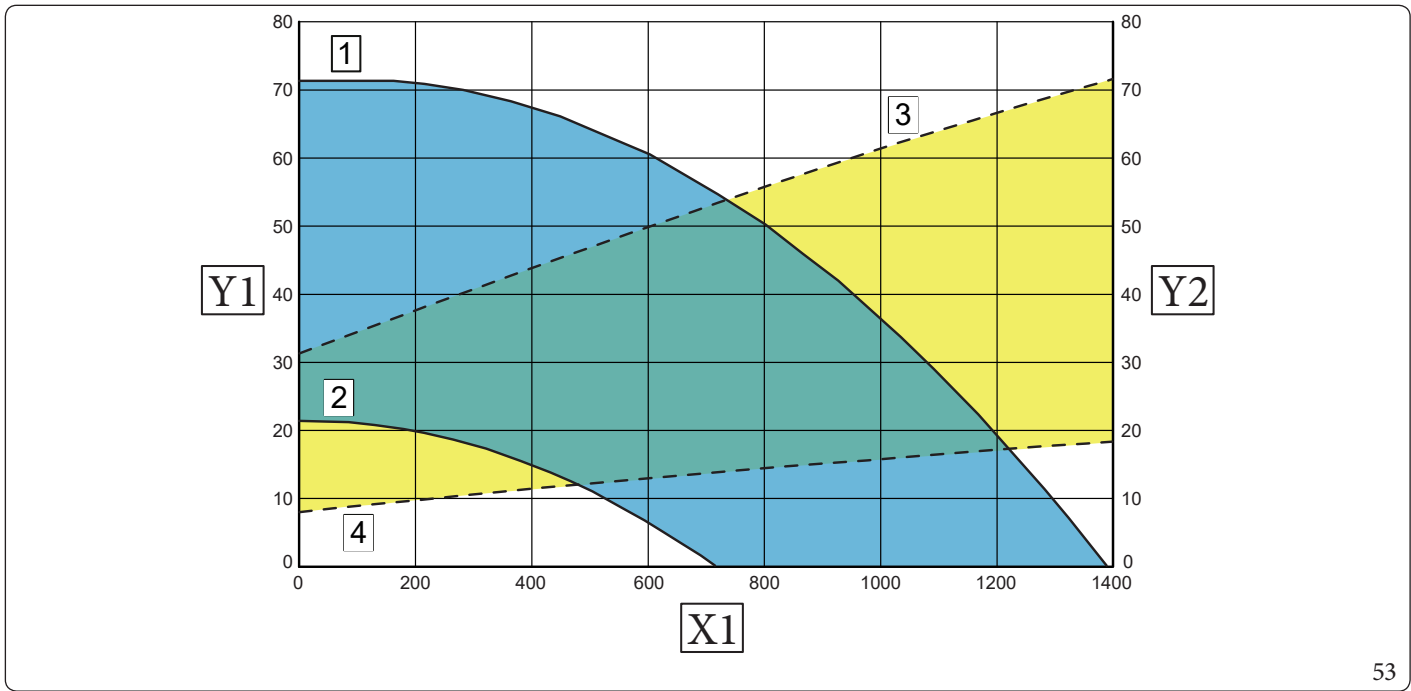

Key (Fig. 53):

- 1 = Head available to the system at speed 100% with by-pass closed
- 2 = Head available to the system at speed 60% with by-pass closed
- 3 = Circulator power input at Speed 100% with closed by-pass
- 4 = Circulator power input at Speed 60% with closed by-pass
- Area between curves 1 and 2 = Available system head with bypass closed
- Area between curves 3 and 4 = Circulator absorbed power with bypass closed

- X1 = Flowrate (l/h)
- Y1 = Head (kPa)
- Y2 = Power absorbed by pump (W)

### 1.41 KITS AVAILABLE ON REQUEST



Check the complete list of kits available and which can be combined with the product, consult the Immergas website, the Immergas Price List or the technical-commercial documentation (catalogues and data sheets).

INSTALLER

USER

CONTROL PANEL

MAINTENANCE TECHNICIAN

TECHNICAL DATA



# 1.42 MAIN COMPONENTS

INSTALLER

USER

CONTROL PANEL

MAINTENANCE TECHNICIAN

TECHNICAL DATA

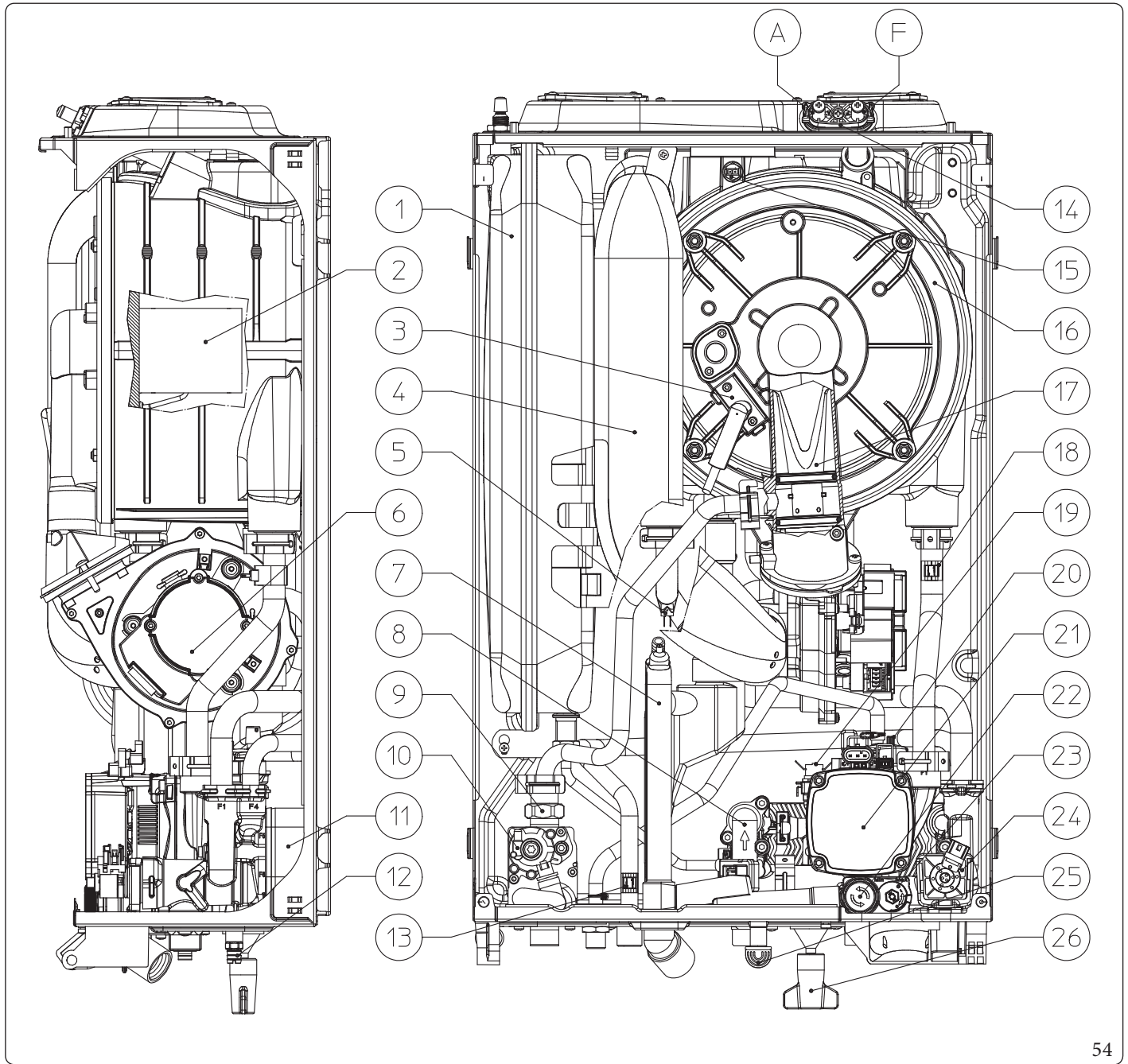

Key (Fig. 54):

- |    |   |                              |    |   |  |
|----|---|------------------------------|----|---|--|
| 1  | - | System expansion vessel      | 14 | - | Sample points (air A) - (flue gases F) |
| 2  | - | Burner                       | 15 | - | Flue probe                             |
| 3  | - | Ignition/detection electrode | 16 | - | Condensation module                    |
| 4  | - | Air intake pipe              | 17 | - | Venturi                                |
| 5  | - | Flow probe                   | 18 | - | Return probe                           |
| 6  | - | Fan                          | 19 | - | System pressure switch                 |
| 7  | - | Condensate drain trap        | 20 | - | Air vent valve                         |
| 8  | - | D.H.W. flow switch           | 21 | - | Appliance pump                         |
| 9  | - | Gas nozzle                   | 22 | - | 3 bar safety valve                     |
| 10 | - | Gas valve                    | 23 | - | By-pass                                |
| 11 | - | D.H.W. heat exchanger        | 24 | - | 3-way valve (motorised)                |
| 12 | - | System draining valve        | 25 | - | Valve drain fitting signal             |
| 13 | - | D.H.W. probe                 | 26 | - | System filling valve                   |







# 2 INSTRUCTIONS FOR USE AND MAINTENANCE

## 2.1 GENERAL RECOMMENDATIONS

 **Never expose the wall-mounted appliance to direct vapours from a hob.**

 The device can be used by children at least 8 years old as well as by persons with reduced physical, sensory or mental capabilities, or lack of experience or required knowledge, provided that they are under surveillance, or after they have been instructed relating to the safe use and have understood the potential dangers.  
Children must not play with the appliance.  
Cleaning and maintenance destined to be performed by the user can not be carried out by unsupervised children.

 **For safety purposes, check that the air intake/flue exhaust terminals (if fitted) are not blocked.**

 If temporary shutdown of the appliance is required, proceed as follows:  
a) drain the heating system if antifreeze is not used;  
b) shut-off all electrical, water and gas supplies.

 In the case of work or maintenance to structures located in the vicinity of ducting or devices for flue extraction and relative accessories, switch off the appliance and on completion of operations ensure that a qualified technician checks efficiency of the ducting or other devices.

 **Never clean the appliance or connected parts with easily flammable substances.**

 **Never leave containers or flammable substances in the same environment as the appliance.**

 Do not open or tamper with the appliance.

 Do not take apart or tamper with the intake and exhaust pipes.

 Only use the user interface devices listed in this section of the booklet.

INSTALLER

USER

CONTROL PANEL

MAINTENANCE TECHNICIAN

TECHNICAL DATA





**Do not climb on the appliance, do not use the appliance as a support base.**



In the event of malfunctions, faults or incorrect operation, turn the appliance off and contact an authorised company (e.g. the Authorised Technical Assistance Centre, which has specifically trained staff and original spare parts).  
Do not attempt to modify or repair the appliance alone.



**The use of components involving use of electrical power requires some fundamental rules to be observed such as:**

- do not touch the appliance with wet or moist parts of the body; do not touch when barefoot;
- never pull electrical cables or leave the appliance exposed to atmospheric agents (rain, sunlight, etc.);
- the appliance power cable must not be replaced by the user;
- in the event of damage to the power supply cable, switch off the appliance and contact exclusively qualified staff for replacement;
- if the appliance is not to be used for a certain period, disconnect the main appliance external switch.



**Water at a temperature of more than 50 °C can cause serious burns.  
Always check the water temperature before any use.**



The temperatures indicated by the display have a tolerance of +/- 3°C due to environmental conditions that cannot be blamed on the appliance.



**If you smell gas in the building:**

- close the gas meter interception device or the main interception device;
- if possible, close the gas interception valve on the product;
- if possible, open doors and windows wide and create an air current;
- do not use open flames (e.g. lighters, matches);
- do not smoke;
- do not use electrical switches, plugs, door bells, telephones or intercom devices in the building;
- call an authorised company (e.g. Authorised Technical Assistance Centre).





if you smell burning or see smoke coming out of the appliance, switch it off, disconnect power, close the main gas isolation valve, open the windows and call an authorised company (e.g. Authorised Technical Assistance Centre).



At the end of its service life, the appliance must not be disposed of like normal household waste nor abandoned in the environment, but must be removed by a professionally authorised company as required by current legislation.  
Contact the manufacturer for disposal instructions.

## 2.2 CLEANING AND MAINTENANCE



To preserve the appliance's integrity and keep the safety features, performance and reliability, which distinguish it, unchanged over time, you must execute maintenance operations on a yearly basis in compliance with what is stated in the relative point at "annual check and maintenance of the appliance", in compliance with national, regional, or local standards in force.

INSTALLER

USER

CONTROL PANEL

MAINTENANCE TECHNICIAN

TECHNICAL DATA



## 2.3 APPLIANCE SWITCH-OFF

Switch off the appliance by setting 'stand-by' mode on the control panel, switch off the appliance's outer omnipolar switches and close the gas tap upstream of the appliance.

Never leave the appliance switched on if left unused for prolonged periods.

## 2.4 RESTORE CENTRAL HEATING SYSTEM PRESSURE

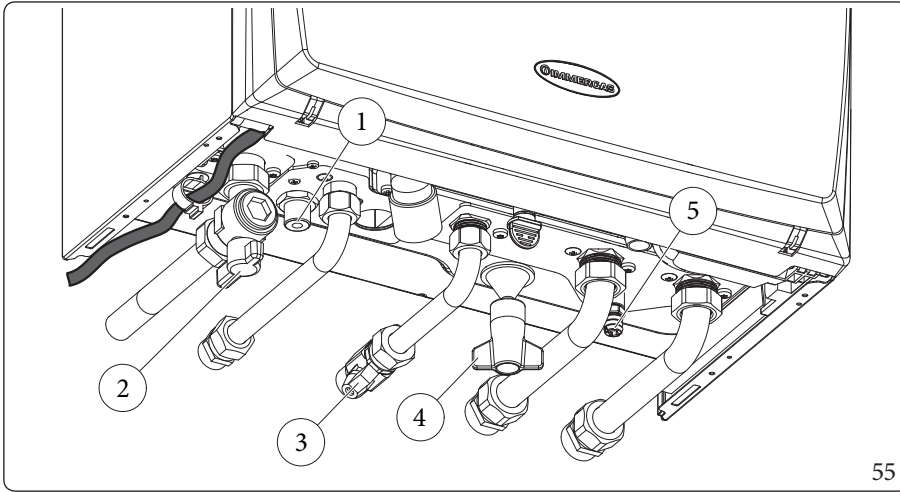

Key (Fig. 55):

- 1 - Safety valve drain
- 2 - GAS isolation valve
- 3 - Cold water inlet valve
- 4 - System filling valve
- 5 - System draining valve

1. Periodically check the system water pressure (the appliance's pressure gauge hand must indicate a cold value between 1 and 1.2 bar).
2. If the pressure is below 1 bar (with the circuit cool), restore normal pressure from the relative valve (Det. 5, Fig. 55).
3. Close the valve after the operation.
4. If the pressure rises to values close to 3 bar, there is a risk of the safety valve tripping (in this case, remove water from an air release valve on a radiator or by acting on the drain valve (Det. 5, Fig. 55) until the pressure is restored to 1 bar, or call in professionally qualified personnel).



**If the system is hot, be sure to let it cool down before draining to avoid the risk of scalding.**

5. In the event of frequent pressure drops, contact qualified staff for assistance to eliminate the possible system leakage.

## 2.5 DRAINING THE SYSTEM

To drain the boiler, use the special draining valve (Part. 5, Fig. 55).

Before draining, ensure that the filling valve is closed.



If fluid containing glycol was added to the system circuit, make sure it is recovered and disposed of in accordance with standard EN 1717.



## 2.6 EMPTYING THE D.H.W. CIRCUIT

To do this, always close the domestic cold water inlet upstream of the appliance. Open any domestic hot water tap to discharge the pressure from the circuit.

## 2.7 ANTIFREEZE PROTECTION

The hybrid heat pump is equipped with an anti-freeze protection function that is active at different levels ("O.U. antifreeze protect." parameter setting).

"Level 1" corresponds to the disabling of the protections.

The "Level 2" protects the outdoor unit by switching on the pump and burner until a temperature calculated on the basis of the outdoor ambient temperature is reached.

The "Level 3" adds a protection to the outdoor unit during domestic hot water supply.



If "Level 3" of the "O.U. antifreeze protect." parameter is active, this function has priority over the domestic hot water production function, so it may happen, in the case of prolonged domestic hot water withdrawals, that domestic hot water production is interrupted.

All information relative to the antifreeze protection is stated in (Parag.1.4).

## 2.8 PROLONGED INACTIVITY

In case of prolonged inactivity (e.g. second home), we recommend:

1. close the gas;
2. to switch off the power supply;
3. completely empty the CH circuit (to be avoided if glycol is present in the system) and the appliance's DHW circuit. In systems that are drained frequently, filling must be carried out with suitably treated water to eliminate hardness that can cause lime-scale.

## 2.9 CLEANING THE CASE

1. Use damp cloths and neutral detergent to clean the appliance casing.



Never use abrasive or powder detergents.

## 2.10 PERMANENT SHUTDOWN

In the event of permanent shutdown of the appliance, contact professional staff for the procedures and ensure that the electrical, water and gas supply lines are shut off and disconnected.



# 3 CONTROL PANEL

## 3.1 CONTROL PANEL

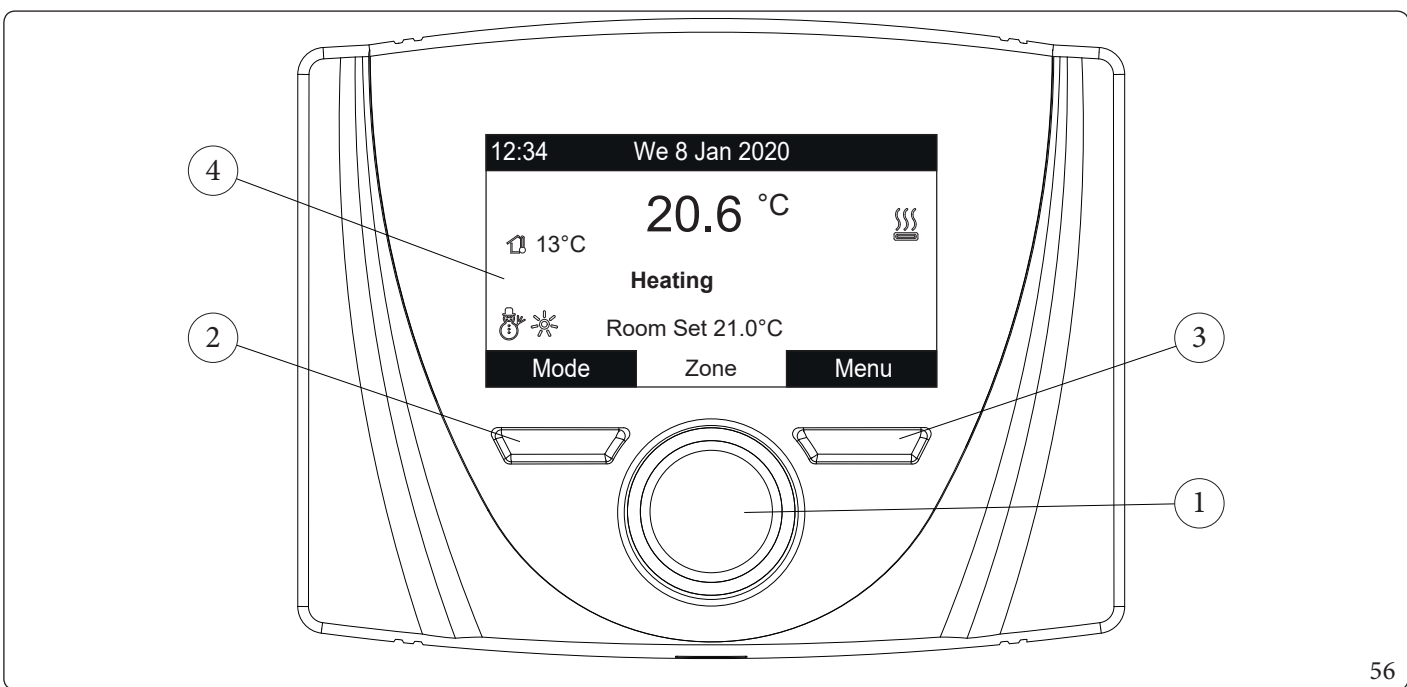

56

Key (Fig. 56):

- 1 - Main parameters switch with button to confirm and save data
- 2 - Left context button
- 3 - Right context button
- 4 - Display

## 3.2 OPERATION OVERVIEW







Once the device has been powered, it goes into the status prior to switch-off. Press the "Modo" (Mode) button to cyclically select the desired mode amongst those available.

The current operating mode in use is displayed by the relative icon at the bottom left corner (Fig. 57).

Operating mode	Description	DHW	Central heating
	Stand-by	Disabled	Disabled
	Summer	Enabled	Disabled
	Winter	Enabled	Enabled

57

Also, depending on the system's configuration, the main screen displays various information regarding the system, amongst which:

Status	Description
	External temperature value (external probe enabled)
	Space central heating request in progress
	Comfort temperature operation
	Economy temperature operation
	Operation in manual mode
	External probe enabled
	Anomaly present

The temperature detected by the temperature is indicated at the centre of the display on the control panel.

The lower part of the display shows the parameter that can be changed (varies depending on the configuration). You can change the value by turning the general selector or by using the "Zone Set Point" menu and pressing to confirm the parameter change.

The values that can be found according to the configuration, are:

Parameter	Configuration (see Parag. 3.6)
<b>Room set</b> Defines the ambient temperature of the zone	Room control interface = P. Rem.
<b>Flow set</b> Defines the system's flow temperature to the zone	Room control interface = T. A. Use of external probe = No
<b>Flow offset</b> Changes the operation curve of the external probe	Room control interface = T. A. Use of external probe = Yes

### 3.3 COMFORT / ECONOMY / MANUAL OPERATION

Once the calendar is set and the relative association of days is executed, the system operates automatically by switching from "comfort" to "economy" according to what has been set.

- **Comfort** (☀️). During periods in comfort mode, a relative icon appears next to the operation mode.
- **Economy** (🌙). During periods in economy mode, a relative icon appears next to the operation mode.
- **Manual** (👤). If the control panel was set to manage the room temperature of the zone, if required, it is possible to change the value manually for a determined range.

By using the control panel to manage room temperature, it is possible to turn the main switch to change the room temperature, and press it to confirm the change. The change is displayed by the symbol "👤".

This change remains active until the next time range is changed from the active calendar.

### 3.4 OPERATION WITH EXTERNAL PROBE

As standard, the system's flow temperature for room central heating is managed by the external probe depending on the external temperature measured.

The operation curve can be changed only by means of the control panel. Operation with external probe can be deactivated as indicated in Par.3.6.



### 3.5 CLOCK AND PROGRAMS

From this menu, it is possible to set the system's date and time as well as the time slots for operation in Comfort and Economy mode.

- **Date and time.**

On first electric supply voltage from the control panel, or in the event of a voltage drop, you must set the date and time. Proceed as follows.

58

- Press the "Menu" button (Ref. 3 Fig. 56), select by pressing the general selector switch (Ref. 1 Fig. 56) the entry 'Clock and Programs', then 'Date and time'.
- Once you have accessed the menu, adjust the various items highlighted by turning the main switch. Set the value and save it by pressing the main switch. Each time it is saved, it moves to the next item.
- When you have finished programming, press the 'Confirm' button.

- **Timeslots**

The control panel enables you to set 4 calendars with 4 time operating slots in system comfort mode. The system will operate in economy mode during out-of-range time of these 4 time slots.

After setting these 4 calendars it is possible to associate them to the various days of the week and DHW function according to one's needs.

59

- Press the "Menu" button (Ref. 3 Fig. 56), select by pressing the general selector switch (Ref. 1 Fig. 56) the entry 'Clock and Programs', then 'Time slots'.
- Once you have accessed the menu, adjust the various items highlighted by turning the main switch. Set the value and save it by pressing the main switch. Each time it is saved, it moves to the next item.
- When you have finished programming, press the 'Confirm' button.





- **Area Program and DHW program**

Time ranges (Calendars from 1 to 4) are assigned to Zone and DHW in these menus. You can assign the calendar to a single day or to a group of days. (single day, Monday - Friday, Saturday - Sunday, Monday - Saturday, Monday - Sunday).

Therefore each day may be personalised with 4 different operating programs.

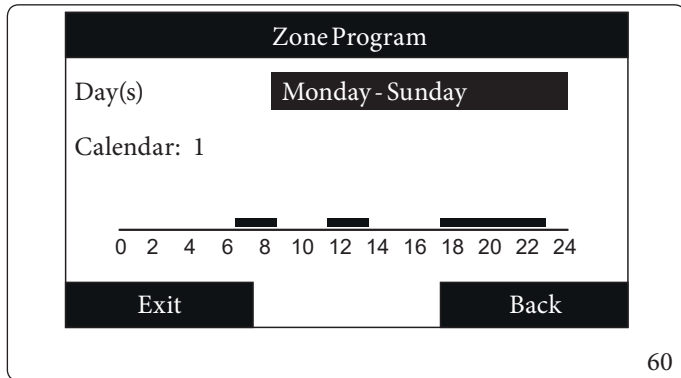

60

For convenient selection, the bottom part displays the graphics of the relevant calendar being selected (Fig. 60).

- **Holiday program** (📅).

If required, it is possible to pause system operation for an established period.

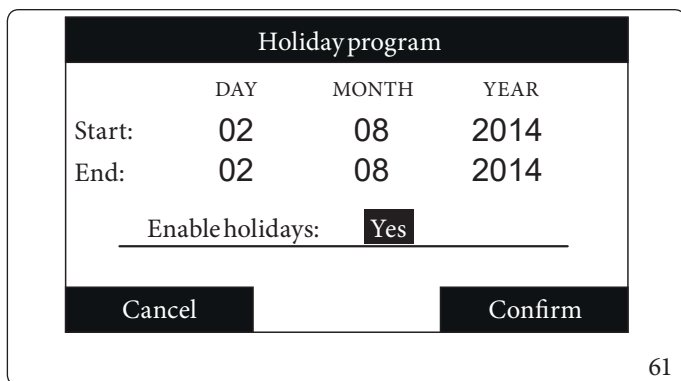

61

Access the "Clock and Programs" menu, select "Holiday program" and set the period in which you wish to pause system operation. During this time, the previously set calendars will not be taken into consideration.

The antifreeze function is still ensured during the holiday period.



### 3.6 P.C.B. PROGRAMMING

Press the "Menu" button to access a list of variables that enable you to customise use of the system.

By modifying these parameters as described below, the system can be adapted according to specific needs.

Access the "Service" menu by pressing the right "Menu" button and turning the main switch until selecting the desired menu. Press the main switch to confirm the selection. Insert the relative access code and customise the parameters according to your requirements.

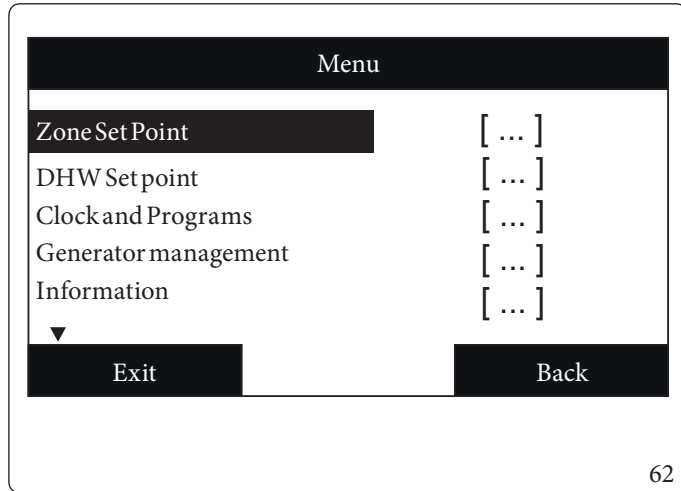

To browse the menus, which can be accessed by pressing the relative "RH" or "LH" context buttons, scroll through the sub-menus displayed by turning the main switch.

Press the said selector to select the one highlighted.

By pressing repeatedly, you can scroll down the menu levels and go back to a previous level by pressing the "Back" context button.

To exit the menu completely, press the "Exit" button, which will take you back to the initial page of normal operation.

To confirm the parameter change, press the main switch.



The list refers to the panel with firmware revision 2.01.

Hereunder is a list of available menus.

MENU' PRINCIPALE		
Menu item	Description	A
Zone Set Point	Defines the operating parameters to manage the zone	
DHW Set point	Defines the operation parameters in domestic circuit mode	
Clock and Programs	Defines the date/time and time operating slots	
Generator management	Defines electricity and gas prices for choosing the generator to be used	
Information	Display system operating data	
Anomalies log	Displays the list of the last 10 anomalies	
Service	Defines advanced operating parameters (password-protected menu dedicated to an authorised technician)	A
Language	Defines the Control panel operation language	

A: menu item accessible only with entry of a service technician password.

Menu "Zone Set Point"					
Menu item	Description	Range	Default	Customised value	A
Heat.comfort set	Room temperature in central heating zone Comfort mode	15 ÷ 35°C	20		
Heat.economy set	Room temperature in central heating zone Economy mode	5 ÷ 25°C	17		
Flow set	Flow temperature in central heating mode	25 ÷ 80°C	40		
Flow offset	Offset temperature for central heating zone (only used with operation with external probe)	- 15 ÷ + 15°C	0		

A: menu item accessible only with entry of a service technician password.



Menù "DHW Set point"					
Menu item	Description	Range	Default	Customised value	A
Comfort set	DHW temperature in Comfort phase	30 ÷ 60°C	50		
Economy set	DHW storage temperature in Economy phase	30 ÷ 45°C	30		
Disinfect	Not used on this model	-	-		

A: menu item accessible only with entry of a service technician password.

Menù "Clock and Programs"					
Menu item	Description	Range	Default	Customised value	A
Date and time	Current date and time setting				
Time slots	Defines the time range for operation in Comfort and Economy mode	0-24,0-45	00:00		
	Calendar 1 Slot 1 ON				
Zone Program	Time zone scheduling				
	Zone: Monday	CAL1,CAL2, CAL3,CAL4	CAL1		
	Zone: Tuesday	CAL1,CAL2, CAL3,CAL4	CAL1		
	Zone: Wednesday	CAL1,CAL2, CAL3,CAL4	CAL1		
	Zone: Thursday	CAL1,CAL2, CAL3,CAL4	CAL1		
	Zone: Friday	CAL1,CAL2, CAL3,CAL4	CAL1		
	Zone: Saturday	CAL1,CAL2, CAL3,CAL4	CAL1		
	Zone: Sunday	CAL1,CAL2, CAL3,CAL4	CAL1		
	DHW Program	DHW operation time programming			
DHW (Domestic hot water) - Monday		CAL1,CAL2, CAL3,CAL4	CAL1		
DHW (Domestic hot water) - Tuesday		CAL1,CAL2, CAL3,CAL4	CAL1		
DHW (Domestic hot water) - Wednesday		CAL1,CAL2, CAL3,CAL4	CAL1		
DHW (Domestic hot water) - Thursday		CAL1,CAL2, CAL3,CAL4	CAL1		
DHW - Friday		CAL1,CAL2, CAL3,CAL4	CAL1		
DHW (Domestic hot water) - Saturday		CAL1,CAL2, CAL3,CAL4	CAL1		
DHW (Domestic hot water) - Sunday		CAL1,CAL2, CAL3,CAL4	CAL1		
Holiday program	Defines the period during which the system deactivates both the hot water heating and the space heating and/or cooling function. At the end of the set days, the previously active functions are restored.		Deactive		

A: menu item accessible only with entry of a service technician password.

INSTALLER

USER

CONTROL PANEL

MAINTENANCE TECHNICIAN

TECHNICAL DATA



Menù "Generator management"					
Menu item	Description	Range	Default	Customised value	A
Electricity price F1	Allows to enter the price of electricity in € per kWh for time slot 1	0 ÷ 2.55 €/kWh	0,23		
Electricity price F2	Allows to enter the price of electricity in € per kWh for time slot 2	0 ÷ 2.55 €/kWh	0,23		
Electricity price F3	Allows to enter the price of electricity in € per kWh for time slot 3	0 ÷ 2.55 €/kWh	0,23		
Gas price	Allows to enter the methane price in € per cubic metre.	0 ÷ 2,55 €/m <sup>3</sup>	0,95		
Gas type	Defines the type of gas with which the I.U. is supplied.	Methane\LPG (m3)\LPG (L)\ Prop. air	Methane		

A: menu item accessible only with entry of a service technician password.

Menù "Information"		
Menu item	Description	A
O.U. flow temp.	Outdoor unit flow temperature	
O.U. return temp.	Outdoor unit return temperature	
I.U. flow temp.	Indoor unit flow temperature	
External temperature	External temperature detected by the outdoor unit	
Calc. system temp. set	Required flow temperature	
DHW temperature	Temperature of the water in the DHW accumulation (not used in this version)	
I.U. board SW vers.	Indoor unit board software revision	
O.U. board SW vers.	Outdoor unit board software revision	
O.U. gateway SW vers.	Outdoor unit gateway board software revision	
O.U. inverter SW vers.	Outdoor unit inverter software revision	
Display SW vers.	Display software revision installed on the control panel	
Operating mode	Mode: Off / Heating / DHW / Antifreeze / Room Antifreeze / Defrosting	

A: menu item accessible only with entry of a service technician password.

Menù "Anomalies log"		
Menu item	Description	A
Anomalies log	Displays the history log of the last 10 anomalies, see Par.3.17	
Delete history	Deletes the history log of the last 10 anomalies	

A: menu item accessible only with entry of a service technician password.

Menù "Service"			
Menu item	Description	Range	A
System definition	Sub-menu to define the devices connected to the system	-	A
Temperature control	Temperature control setting sub-menu	-	A
O.U. settings	Outdoor unit configuration sub-menu	-	A
Integration	System integration setting sub-menu	-	A
Generator info	System information sub-menu	-	A
Maintenance	Activation of system maintenance functions	-	A
Restore default settings	Allows to reset all parameters with factory values	Yes / No	A

A: menu item accessible only with entry of a service technician password.



Menù "Service" -> "System definition"					
Menu item	Description	Range	Default	Customised value	A
Room control interf.	Establishes the temperature control device in use	Rem.C./RT	Rem.C.		A
Pump operation	The pump can function in two ways. - Intermittent: in "winter" mode, the circulator is managed by the control panel or the room thermostat. Continuous = in "Winter" mode the pump is always in operation.	Inter./ Simul.	Inter.		A
Min. pump speed	Minimum speed used value	10 - 100 %	60 %		A
Max. pump speed	Maximum speed used value	10 - 100 %	100 %		A
Pump Delta T	Temperature delta to be maintained	5 - 10	5		A
DHW hysteresis	Not used on this model	-	-		A
Enable room antifreeze	Enables the room antifreeze function	Yes/No	Yes		A
Room antifreeze temp.	Allows to set the room temperature for activation of the anti-freeze function.	3 ÷ 10 °C	5 °C		A

A: menu item accessible only with entry of a service technician password.

Menù "Service" -> "Temperature control"					
Menu item	Description	Range	Default	Customised value	A
Enable external probe	Defines the use of the external probe.	Yes/No	Yes		A
Minimum flow set	With the external probe not in use it defines the minimum flow temperature that can be set by the user. With the external probe enabled it defines the minimum flow temperature corresponding to operation with maximum external temperature	25 ÷ 55	30		A
Maximum flow set	Without the external probe it defines the maximum flow temperature that can be set by the user. With the external probe present it defines the maximum flow temperature corresponding to operation with minimum external temperature	35 ÷ 80	50		A
Minimum external temp.	With the external probe enabled it defines at what external temperature the system must operate at the maximum flow temperature	-25 ÷ +15 °C	-5		A
Maximum external temp.	With the external probe present it defines at what maximum external temperature the system must operate at the minimum flow temperature	-5 ÷ +45 °C	25		A
Modul. with room probe	It enables you to set operation of the control panel as ON/OFF or modulating. Set "Yes", the flow temperature will be varied depending on the room temperature set. Set "No", the flow temperature will be kept constant until the desired room temperature is reached. N.B.: if an outdoor temperature probe is enabled, the flow temperature will be set depending on the relative functioning curve.	Yes/No	Yes		A
Inertia or dimension	It establishes the system reaction speed according to the type of system present. Example: 5 system with little heat inertia 10 system with normal dimensions with radiators 20 system with a lot of heat inertia (e.g. floor-standing system)	1 ÷ 20	10		A

A: menu item accessible only with entry of a service technician password.

Menù "Service" -> "O.U. settings"					
Menu item	Description	Range	Default	Customised value	A
Enab. Heater kit	Enables operation of the heater kit	Yes/No	No		A
Reduction function	Enables a reduction of PdC noise.	No/Level 1/ Level 2	No		A
O.U. antifreeze protect.	Indicate the presence of antifreeze fluid in the system	Level 1/Level 2/ Level 3	Level 3		A

A: menu item accessible only with entry of a service technician password.

INSTALLER

USER

CONTROL PANEL

MAINTENANCE TECHNICIAN

TECHNICAL DATA



Menù "Service" -> "Integration"					
Menu item	Description	Range	Default	Customised value	A
Enable DHW integr.	Not used on this model.	--	--		A
Enable heat. integr.	Enables IU operation in CH mode if the EU is not sufficient to reach the set point.	Yes/No	Yes		A
DHW waiting time	Not used on this model.	--	--		A
Heat. waiting time	Waiting time to reach the setting set before activation of the integration in room heating.	0 - 240 (5 minute steps)	20'		A
Integration band	If the flow temperature of the outdoor unit is lower than the heating-set value minus the activation band divided by 2, then after a period equal to the activation delay time, the indoor unit will be turned on.	0 ÷ 15 °C	3		A
Integration mode	It determines whether the heat generator integration is activated at a fixed temperature or automatically by means of the cost-effectiveness calculation.	AUTO/MAN	MAN		A
DHW activation temp.	Not used on this model.	--	--		A
Heat. activation temp.	If "Integration mode = MAN" is set, the outdoor temperature is established below which central heating of the indoor unit only is enabled.	-14 ÷ 25 °C	0		A

A: menu item accessible only with entry of a service technician password.

Menù "Service" -> "Generator info"		
Menu item	Description	A
O.U. working parameters	Submenu for the working data of the outdoor unit	A
O.U. Status	Submenu for the operating status of the outdoor unit	A
System State	Submenu for the operating status of the system	A

A: menu item accessible only with entry of a service technician password.

Menù "Service" -> "Generator info" -> "O.U. working parameters"		
Menu item	Description	A
Flow temp.	Instant outlet temperature from the outdoor unit	A
Return temp.	Outdoor unit return temperature	A
Calc. sys. temp. set O.U.	Flow set point determined by the outdoor unit	A
Calc. DHW temp. set	DHW set point determined by the outdoor unit	A
Compress. outlet temp.	Outdoor unit compressor temperature	A
Cool. temp. on exch.	Coolant temperature inside the plate heat exchanger	A
Evaporator temp.	Evaporator temperature	A
External temperature	External room temperature	A
Compressor frequency	Current compressor frequency	A

A: menu item accessible only with entry of a service technician password.

Menù "Service" -> "Generator info" -> "O.U. Status"		
Menu item	Description	A
O.U. Heating req.	Indicates the presence of a heating demand to the U.E.	A
O.U. DHW req.	Indicates the presence of a DHW demand to the U.E.	A
O.U. operational	Indicates that the heat pump is available	A
O.U. startup time	Time elapsed since the U.E. start-up request	A
Defrosting	Indicates that the defrosting of the outdoor unit is in progress	A
O.U. in antifreeze	Indicates that the heat pump is performing an antifreeze function	A
Cool start	Indicates the machine was cold started	A
O.U. exchanger preheat.	Not used on this model	A
O.U. fault level	It identifies the presence of alterations to operation of the O.U.	A
O.U. fault status	Indicates whether the O.U. is stopped due to an anomaly	A

A: menu item accessible only with entry of a service technician password.



**Menù "Service" -> "Generator info" -> "System State"**

Menu item	Description	Range	Default	Customised value	A
Pump speed	Circulator speed status	0 - 100 %			A
Pump flow rate	Indicates circulation inside the hydraulic circulator	0 - 2000l/h (reading only)			A
DHW 3-way	DHW three-way status	DHW / Heat / Mix			A
Calc. system temp. set	Flow set point determined by temperature control				A
O.U. max calculated set	Maximum flow set point calculated for the outdoor unit				A
System Status	Immergas after sales service diagnostic value				A
Heater Status	Immergas after sales service diagnostic value				A

A: menu item accessible only with entry of a service technician password.

**Menù "Service" -> "Maintenance"**

Menu item	Description	Range	Default	Customised value	A
Pump down	Function for gas removal on water/gas heat exchanger	Off / On			A
Heater kit test	UE anti-freeze resistance kit control outlet forcing	Off / On			A
Pump flow rate	Indicates circulation inside the hydraulic circulator	0 - 2000l/h (only reading)			A

A: menu item accessible only with entry of a service technician password.

**Menù "Language"**

Menu item	Description	Range	Default	Customised value	A
Language	Defines the Control panel operation language	ITA, ENG, SPA, CZE, RUM, HUN, POL, SLO	ENG		

A: menu item accessible only with entry of a service technician password.

INSTALLER

USER

CONTROL PANEL

MAINTENANCE TECHNICIAN

TECHNICAL DATA



### 3.7 INDOOR UNIT CONTROL PANEL

INSTALLER

USER

CONTROL PANEL

MAINTENANCE TECHNICIAN

TECHNICAL DATA

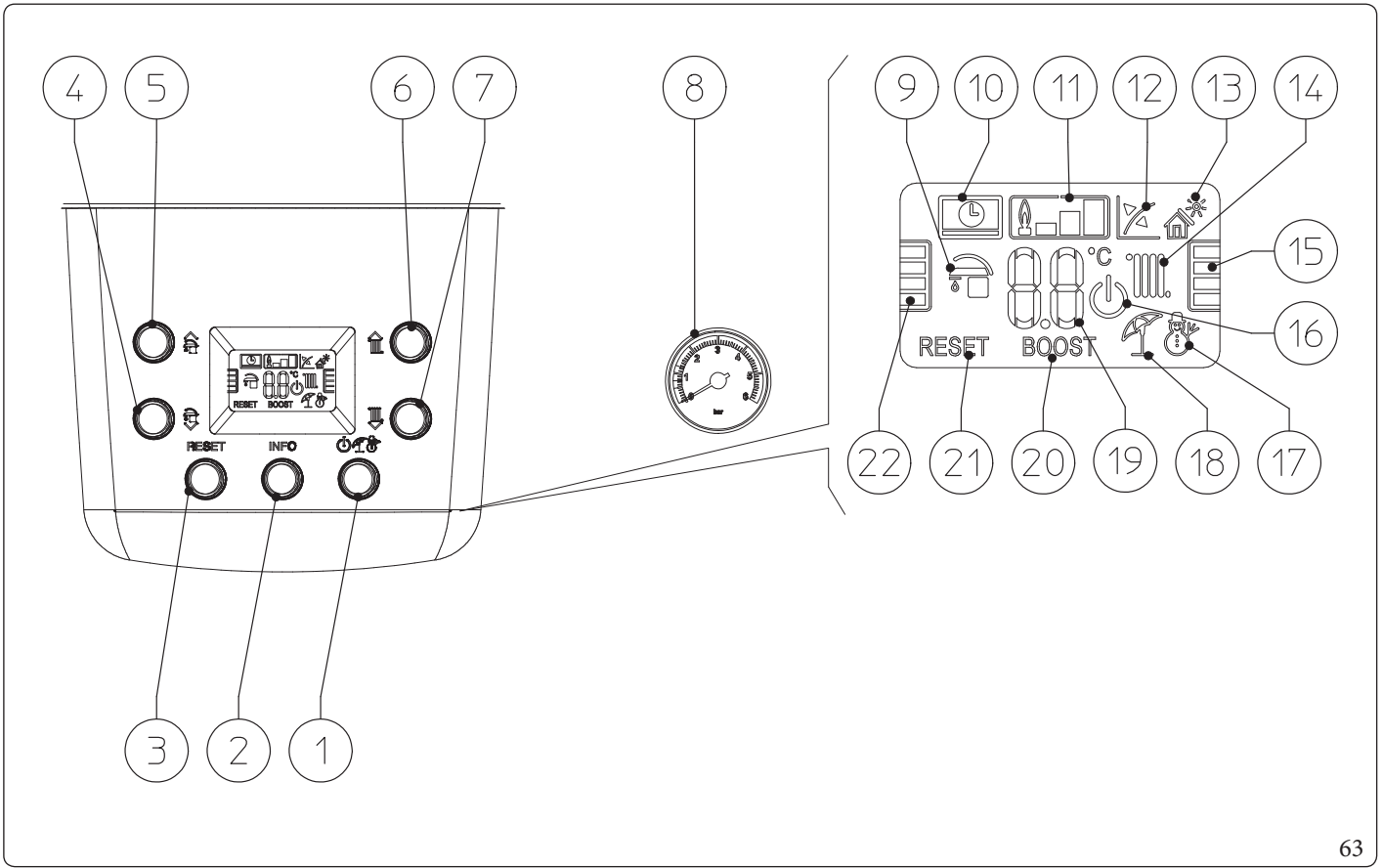

Key (Fig. 63):

- |   |  |
|---|--|
| <ul style="list-style-type: none"> <li>1 - Off/ Stand-by/ Summer/ Winter buttons (Not used on this model)</li> <li>2 - Information buttons</li> <li>3 - Reset Button</li> <li>4 - Button to decrease the DHW temperature (Not used on this model)</li> <li>5 - Button to increase the DHW temperature (Not used on this model)</li> <li>6 - Button to increase the system water flow temperature (Not used on this model)</li> <li>7 - Button to decrease the system water flow temperature (Not used on this model)</li> <li>8 - Indoor unit pressure gauge</li> <li>9 - DHW production phase operating mode active</li> </ul> | <ul style="list-style-type: none"> <li>10 - Indoor unit connected to control panel</li> <li>11 - Flame presence symbol and relative output scale</li> <li>12 - Not used on this model</li> <li>13 - Solar function active</li> <li>14 - Central heating room mode function active</li> <li>15 - Central heating temperature level indicator</li> <li>16 - Indoor Unit in Stand-by Mode</li> <li>17 - Operation in winter mode</li> <li>18 - Operation in summer mode</li> <li>19 - Temperature indicator, indoor unit info and error codes</li> <li>20 - Not used on this model</li> <li>21 - Locked indoor unit, it needs to be unlocked by pressing the "RESET" button</li> <li>22 - D.H.W. temperature level indicator</li> </ul> |
|---|--|





### 3.8 SYSTEM USE



Before ignition make sure the heating system is filled with water and that the pressure gauge (8, Fig. 63) indicates a pressure of 1 - 1.2 bar.

– Open the gas isolation valve upstream from the indoor unit.

The indoor unit operates automatically according to the settings on the control panel. With no demand for heat (central heating or domestic hot water production) the indoor unit goes to "standby" function, equivalent to the indoor unit being powered without presence of flame.

Each time the burner ignites, the relative flame present symbol is displayed (11, Fig. 63) with relative output scale.

#### Solar operating mode (☀️\*)

This function is activated automatically if the indoor unit detects a probe on the DHW inlet (optional) or if the "Solar ignition delay" parameter is more than 0 seconds.

During a withdrawal, if the inlet water is hot enough or if there is "Solar ignition delay" time, the indoor unit does not switch on, the D.H.W. withdrawal symbol (🚰) appears on the display along with the flashing solar function symbol (☀️\*).

When the water supplied by the solar system is at a temperature lower than what is set, and if the "Solar ignition delay" time has elapsed, the appliance switches on. At this point, the solar function symbol remains permanently on.

#### "Off" mode

By holding the "🔌🔧" button down for 8 seconds, the display switches-off and the indoor unit is off completely. The safety functions are not guaranteed in this mode.



**In "Stand-by" and "Off" mode, the appliance is to be considered still live. In "Off" mode, a lit "dot" is displayed in the centre of the display.**

#### Display operation

The display lights up while the control panel is being used; after a set inactivity period, the brightness drops until only the active symbols are displayed. The lighting mode can be varied via parameter "t8" in the P.C.B. programming menu.



### 3.9 INDOOR UNIT P.C.B. PROGRAMMING

The device is prepared for possible programming of several operation parameters. By modifying these parameters as described below, the device can be adapted according to specific needs.

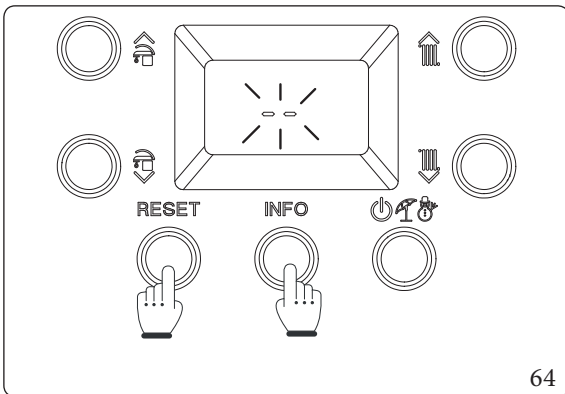

To access the programming phase, press and hold the buttons "RESET" and "INFO" for more than 5 seconds; the display shows two dashes "--" flashing and you must enter the password (69) to access the programming menus.

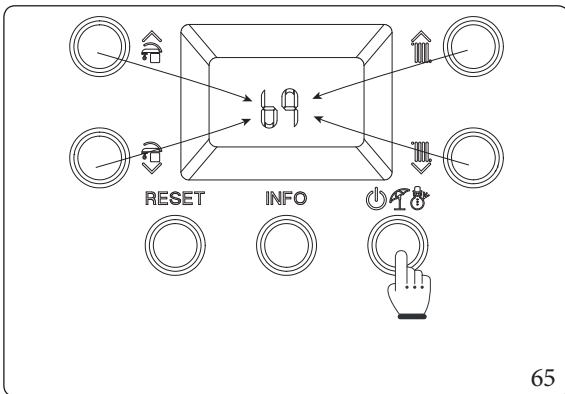

To enter the first digit, use the buttons to adjust the DHW "6"; to enter the second digit, use the buttons to adjust the central heating temperature "9". To confirm the password and access the menu, press the operating mode button "mode".

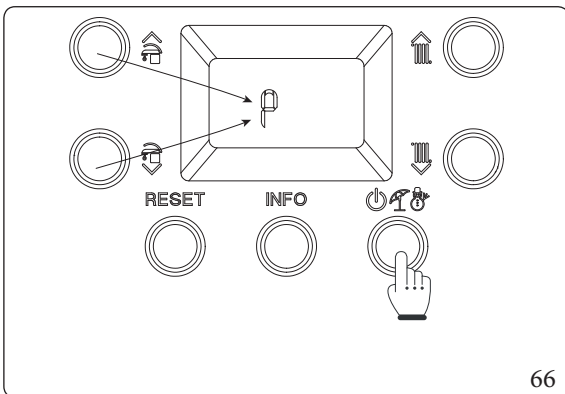

Once in the menu, you can cyclically scroll the four submenus (P, t, A, S) by pressing the DHW buttons "mode", to access the menu press the button "mode".

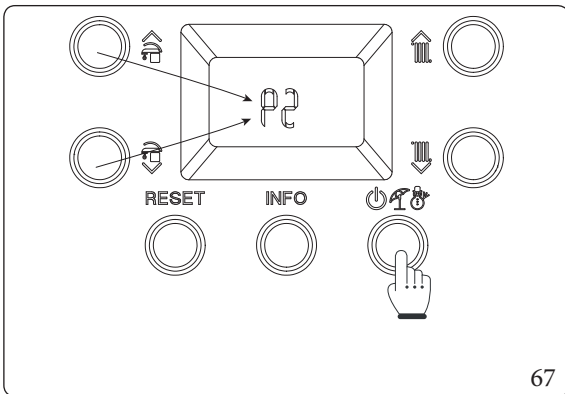

The first digit of the central indicator (Ref. 19, Fig. 63) shows the family of the parameter, while the second digit shows its number.

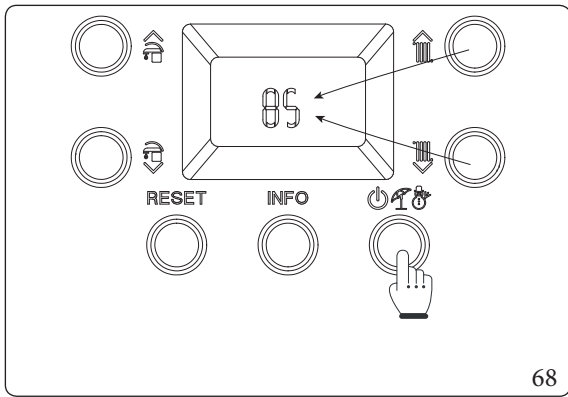

Pressing the mode of operation button "⏻➡" displays the value of the selected parameter and by pressing the buttons to adjust the central heating temperature "⬆️⬇️" you can adjust its value.

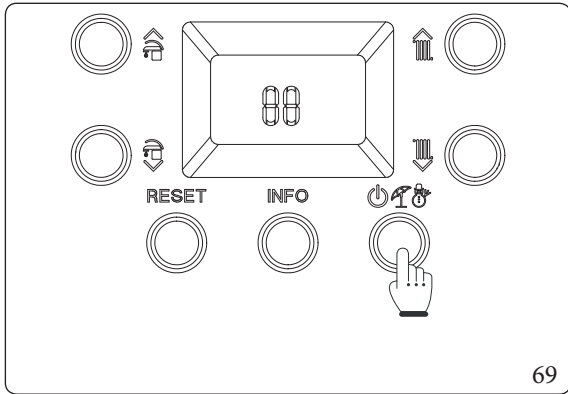

Press the mode of operation button "⏻➡" for more than 1 second to store the parameter value; confirmation is given by the word "88" which appears for 2 seconds.

If you want to exit a parameter without changing its value, press the button "RESET".  
Wait for 15 minutes or press the "RESET" button to exit programming mode.

Programming phase sequence							
RESET + INFO > 5"	'P', 't', 'A', 'S' ⬆️⬇️ menu	< RESET ⏻➡➡	P0 ÷ P5 t0 ÷ t9 A0 ÷ A6 S0 ÷ S2 ⬆️⬇️	< RESET ⏻➡➡	Parameter value ⬆️⬇️	< RESET (without memorising) ⏻➡➡ > 1" (Memorise)	88



Id Parameter	Parameter	Description	Range	Default	Customised value
P0	Max DHW output	Defines the maximum heat output percentage of the Indoor Unit during the DHW mode compared to the maximum heat output available	0 - 100 %	100 %	
P1	Min CH output	Defines in percentage the minimum output in central heating mode	0 - P2	0 %	
P2	Max CH output	Defines the maximum heat output percentage of the Indoor Unit during the central heating mode compared to the maximum heat output available	0 - 100 %	VICTRIX 24HY	
				G20 = 85	
				G31 = 82	
				VICTRIX 32HY	
				G20 = 85	
G31 = 85					
P3	UIP.C.B. relay operation	0 = OFF 1 = Not available 2 = General alarm 3 = CH phase mode 4 = External gas valve power supply 5 = Not available 6 = U.I. circulator command 7 = Not available 8 = Not available 9 = Not available 10 = Not available	0 - 10	0	
P4	Pump functioning	Set this parameter from the control panel. see Par. 3.6			
P5	External probe correction	If the reading of the external probe is not correct it is possible to correct it in order to compensate any environmental factors.	-9 ÷ 9 K	0	
P6	-	Not available for this model	-	-	
P7	-	Not available for this model	-	-	
P8	Three way delay standby OFF UE	Management of three-way commutation delay for UE switch of standby	0 - 30	7	

<b>Id Parameter</b>	<b>Parameter</b>	<b>Description</b>	<b>Range</b>	<b>Default</b>	<b>Customised value</b>
t0	Central heating set point minimum temperature	Set this parameter from the control panel. see Par. 3.6			
t1	Central heating set point maximum temperature	Set this parameter from the control panel. see Par. 3.6			
t2	Solar delay timing	The indoor unit is set to switch-on immediately after a DHW demand. When combined with a solar cylinder placed upstream of the indoor unit, it is possible to compensate for the distance between the cylinder and the indoor unit to allow hot water to reach the latter. Set the time necessary to verify that the water is hot enough (see par. Solar panels coupling)	0 - 30 seconds		
t3	D.H.W. priority timing	Set this parameter from the control panel. see Par. 3.6			
t4	Central heating ignitions timer	Set this parameter from the control panel. see Par. 3.6			
t5	Heating ramp timing	Set this parameter from the control panel. see Par. 3.6			
t6	CH ignition delay from TA and CR request	Set this parameter from the control panel. see Par. 3.6			
t7	Display lighting	Establishes the display lighting mode. 0: the display lights up during use and lowers after 15 seconds of inactivity. In the case of anomaly the display flashes. 1: display lighting off. 2: the display is always lit up.	0 - 2		
t8	Display	Establishes what the indicator displays 19 (Fig. 63). "Summer" mode: 0: the indicator is always off 1: pump active displays the flow temperature, pump off the indicator is off "Winter" mode: 0: it always displays the value set on the central heating selector 1: circulator pump active displays the flow temperature, pump off displays the value set on the central heating selector			
t9	Flow off temperature increase	Increases the flow off temperature at ignition only in the first 60 seconds. After the flame is detected, the temperature is increased by t9			

INSTALLER

USER

CONTROL PANEL

MAINTENANCE TECHNICIAN

TECHNICAL DATA



<b>Id Parameter</b>	<b>Parameter</b>	<b>Description</b>	<b>Range</b>	<b>Default</b>	<b>Customised value</b>
A0	Hydraulic model	Defines the type of hydraulics in the indoor unit (0 = instantaneous; 1 = cylinder)	0 ÷ 1	0	
A1	Maximum pump speed	Set this parameter from the control panel. see Par. 3.6			
A2	Minimum pump speed	Set this parameter from the control panel. see Par. 3.6			
A3	Circulating pump mode	Set this parameter from the control panel. see Par. 3.6			
A4	Storage tank flow offset	Not available for this model	--	--	
A5	Storage tank DHW hysteresis	Not available for this model	--	--	
A6	D.H.W. thermostat	Establishes the switch-off method in DHW mode. 0 Fixed: the switch-off temperature is fixed at the maximum value regardless of the value set on the control panel. 1 Correlated: the boiler switches off according to the temperature set.	0 ÷ 1	0	

### Victrix24HY

<b>Id Parameter</b>	<b>Parameter</b>	<b>Description</b>	<b>Range</b>	<b>Default</b>	<b>Customised value</b>
S0	DHW minimum no. of fan revs	Defines the operating speed of the fan at minimum DHW output	20 - 60 (x50 = RPM)	27 (G20)	
				26 (G31)	
S1	DHW maximum no. of fan revs	Defines the operating speed of the fan at maximum DHW output	S0 - 140 (x50 = RPM)	121 (G20)	
				115 (G31)	
S2	Ignition phase no. of fan revs	Defines the operating speed of the fan during the ignition phase	40 - 80 (x50 = RPM)	44 (G20)	
				44 (G31)	

INSTALLER

### Victrix32HY

<b>Id Parameter</b>	<b>Parameter</b>	<b>Description</b>	<b>Range</b>	<b>Default</b>	<b>Customised value</b>
S0	DHW minimum no. of fan revs	Defines the operating speed of the fan at minimum DHW output	20 - 60 (x50 = RPM)	27 (G20)	
				27 (G31)	
S1	DHW maximum no. of fan revs	Defines the operating speed of the fan at maximum DHW output	S0 - 140 (x50 = RPM)	128 (G20)	
				119 (G31)	
S2	Ignition phase no. of fan revs	Defines the operating speed of the fan during the ignition phase	40 - 80 (x50 = RPM)	56 (G20)	
				56 (G31)	

USER

CONTROL PANEL

MAINTENANCE TECHNICIAN

TECHNICAL DATA



### 3.10 PASSWORD-PROTECTED SPECIAL FUNCTIONS



The appliance is equipped with some special functions, access to which is granted if this is in stand-by (⏻).



The 'stand-by' function can only be obtained via the control panel.

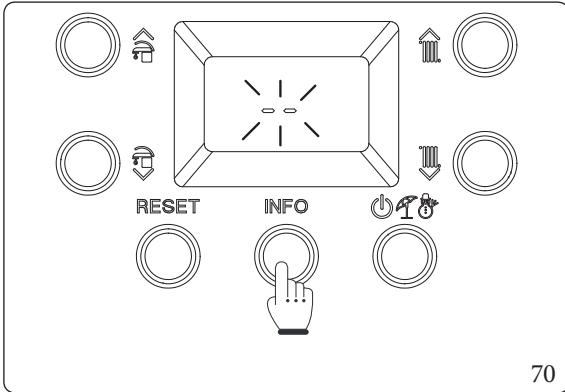

Press and hold the “INFO” button for more than 5 seconds. The display will show two dashes “--” flashing. Now enter the password (69) to access the programming menus.

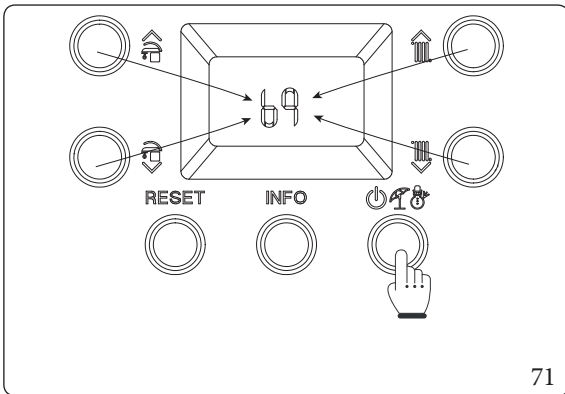

To enter the first digit, use the buttons to adjust the DHW “”; to enter the second digit, use the buttons to adjust the central heating temperature “”. To confirm the password and access the menu, press the operating mode button “”

Once the menu has been accessed, it is possible to cyclically scroll the three available functions (dl, MA, FU) by pressing the DHW buttons “”, to access the menu press the button “” to exit wait 15 minutes or press the button “RESET”.





### 3.11 AUTOMATIC VENT FUNCTION (DL)

In the case of new central heating systems and in particular mode for floor systems, it is very important that deaeration is performed correctly. The function consists of the cyclic activation of the pump (100 s ON, 20 s OFF) and the 3-way valve (120 s D.H.W., 120 s C.H.). The function is activated by accessing the special "dl" function as described in the Paragraph 3.10. The function lasts for 16.5 hours and it can be stopped by simply pressing the button "RESET". Activation of the function is signalled by the countdown displayed on the indicator (Ref. 20, Fig. 63).



### 3.12 FLUE INSTALLATION (FU)

To activate the "Flue" function access the special functions as described in Paragraph 3.10 and select the "FU" function.



Before performing the test, ensure that the condensate drain trap has been filled correctly and check that there are no obstructions in the air intake circuit and flue exhaust and that the sealed chamber is perfectly closed and the flue has already been installed.

Using this function activates the fan at a fixed speed (6000 rpm) for 15 minutes.

In this phase the symbols (  ) and (  ) are displayed flashing, while the symbol (  ) is displayed permanently on, the function can be stopped by simply pressing the button "RESET".









### 3.13 MAINTENANCE FUNCTION (MA)

Using this function, you can activate some operating devices of the appliance without starting it, thus verifying operation.

The function is active for 15 minutes and it can be stopped by pressing the button "RESET".

To activate the "Maintenance" function, access the special functions as described in Paragraph 3.10 and select the "MA" function.

The following loads can be activated within this function:

- Fan (Fn): the fan is brought to ignition speed. Using the buttons "   " you can increase or decrease the fan speed.
- Circulator (Pu): the circulator is brought to maximum speed, the relative speed is shown on the display, using the buttons "   " you can increase or decrease the circulator speed.
- Three-way (3d): the symbol is shown on the display according to the position of the valve, DHW (  ) or central heating (  ), using the buttons "   " you can change the valve position, taking care to wait for the completion of passage between statuses.
- Configurable relay (rl): the configurable relay in the boiler is energised.



At the end of manual forcing operations, always switch the indoor unit off and back on before returning to normal operation.



### 3.14 SCREED HEATER

The appliance is equipped with a function to perform the thermal shock on new radiant panel systems, as required by the applicable standard.



Contact the manufacturer of the radiant panels for the thermal shock characteristics and its correct execution.



To be able to activate the function there must be no remote control connected, while in case of system divided into zones it must be properly connected, both hydraulically and electrically.

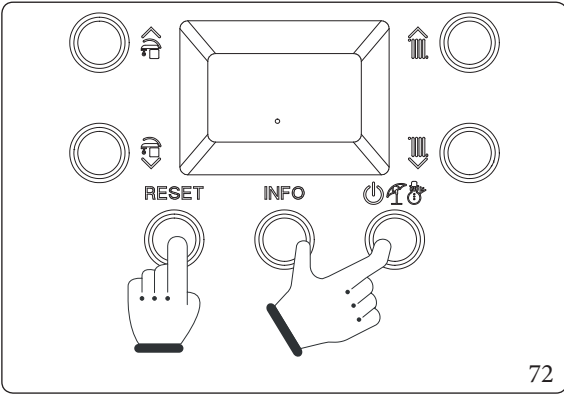

The function is activated from boiler in “off” by pressing and holding the “RESET”, “INFO” and “power” buttons for more than 5 seconds.

The function lasts in total 7 days, 3 days at the lower temperature set and 4 days at the higher temperature set (Fig. 73). After activating the function, the lower set (range 20 ÷ 45 °C default = 25 °C) and the higher set (range 25 ÷ 55 °C default = 45 °C) appear in sequence.

The temperature is selected by means of the buttons "up/down" and confirmed by pressing the button "power".

The display now shows the countdown of days alternated with the current flow temperature, as well as the normal operating symbols of the boiler.

In case of failure or lack of supply voltage, the function is suspended and will resume when the normal operating conditions are reset from the point where it was interrupted.

When the time expires, the boiler automatically goes back to “Stand-by” mode, the function can also be stopped by pressing the “power” button.

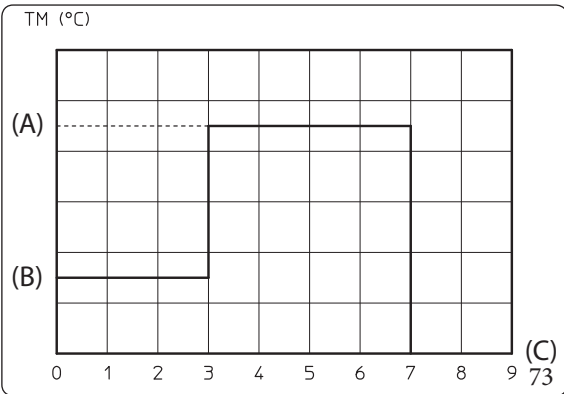

Key (Fig. 73):  
 (A) - Top set  
 (B) - Lower set  
 (C) - Days  
 TM - Flow temperature

### 3.15 CHIMNEY SWEEP

When activated, this function forces the boiler to variable output for 15 minutes.

In this state all adjustments are excluded and only the safety thermostat and the limit thermostat remain active.

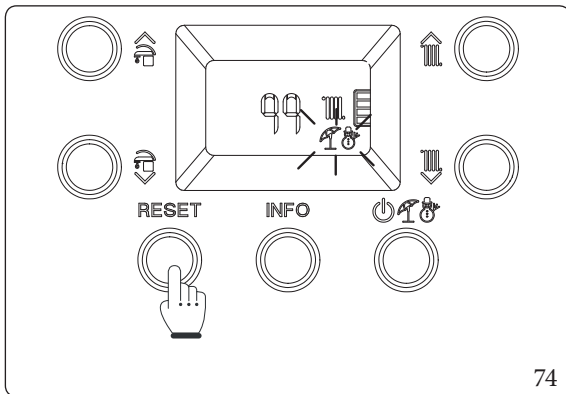

To activate the chimney sweep function, press the “RESET” button until activation of the function in the absence of DHW requests.

Its activation on the boiler display is confirmed by the indicators flashing at the same time (Ref. 17 and 18, Fig.63);

During operation of the indoor unit in chimney sweep mode, 'Error 0007' is displayed on the control panel.

This function allows the technician to check the combustion parameters.

Once the function is activated, it is possible to select whether to make the check in CH status or DHW status by opening any hot water valve.

Using the buttons "⬆️⬆️" you can select between three predefined power levels:

- “0%”;
- Max CH output (P2);
- Max DHW output (P0).

While by using the buttons "⬆️⬇️" you can select the power from 0% to max DHW output (P0), with intervals of 1%.

The central heating or DHW operating mode is displayed by the relative symbols “🔥” or “🚿”.

After the checks, deactivate the function by switching the boiler off and then back on again.

INSTALLER

USER

CONTROL PANEL



MAINTENANCE TECHNICIAN

TECHNICAL DATA



### 3.16 INFORMATION MENU

By pressing the button "INFO", the "Information" menu is activated for at least 1 second, displaying some system operating parameters.

To scroll through the various parameters, press the buttons "DHW regulation"  .

With the menu active on the indicator 19, Fig. 63) the parameter via the letter "d" plus the number of the parameter that is being displayed will alternately show.

To view the parameter value, select it by pressing the button   .

Press "RESET" or wait 15 minutes to go back to the previous screen or exit the menu.

Parameter ID	Description
d0.0	Not used
d0.1	Displays the flame signal
d0.2	Displays the primary heat exchanger outlet instant CH flow temperature (°C)
d0.3	Displays the instant output temperature from the DHW exchanger
d0.4	Displays the values set for central heating set
d0.5	Displays the values set for DHW set
d0.6	Not used
d0.7	Displays the temperature of the inlet DHW (°C) (with optional DHW inlet probe present)
d0.8	Displays the system return water temperature (°C)
d0.9	Displays the list of the last eight faults (to scroll the list press the "central heating temperature regulation" buttons (6 and 7)).
d1.0	Anomaly list reset. Once "d10" is displayed, press Stand-by; the display shows "--". Then press the Stand-by key again for at least 3 seconds; deletion is confirmed via the "88" symbols flashing for two seconds.
d1.1	Not used
d1.2	Displays the pump operating speed
d1.3	Not used
d1.4	Displays the pump flow rate (l/h)
d1.5	Displays the fan operating speed (rpm)
d1.6	Displays the temperature read on the flue probe (°C)
d1.7	Displays the calculated flow temperature (°C)
d1.8	At the end of the screed heater function, displays for how many hours the flow temperature remained at "Top set"
d1.9	Toggles between the safety software version and the functional software version
d2.0	Not used
d2.1	Not used
d2.2	Not used

### 3.17 FAULT AND ANOMALY SIGNALS

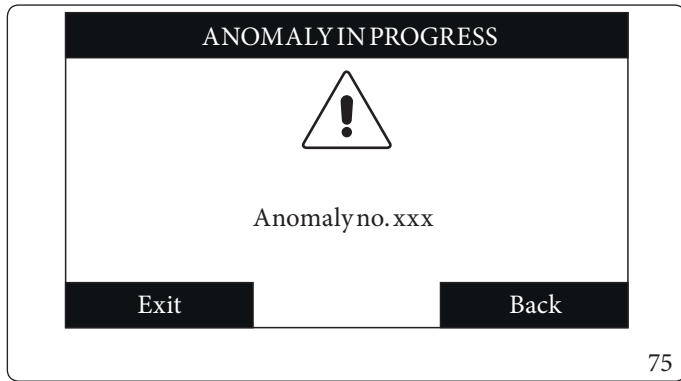

The system signals any anomalies by displaying the attention screen with the relative anomaly code (Fig. 75). Press the "Exit" button to go back to the main screen and the anomaly is displayed with the  symbol.

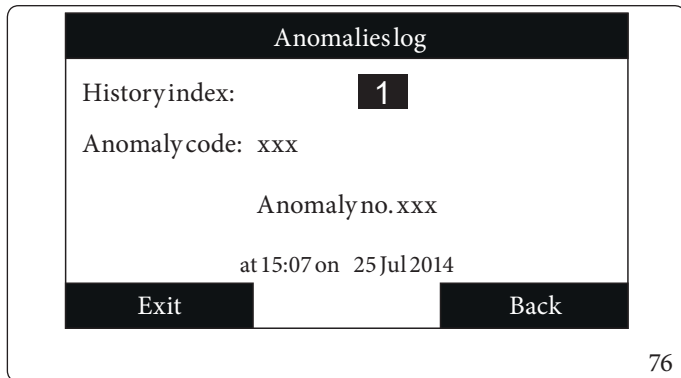

You must access the "Anomalies log" menu to display the anomalies log where the last 10 system anomalies are displayed in time order (Fig.76). Turn the main switch to scroll through the list. Within the "Anomalies log" menu it is also possible to delete the list by selecting yes under "Delete history". Errors relating to the indoor unit are also signalled on its panel.

#### List of Indoor Unit Anomalies

Error Code	Anomaly signalled	Cause	UI Status/ Solution
01	No ignition block	In the event of request of room central heating or domestic hot water production, the system does not switch on within the preset time. Upon Victrix Hybrid commissioning or after extended downtime, it may be necessary to eliminate the block.	Press the Reset button (1)
02	Safety thermostat function block (NTC flow/return overheating)	During normal operation, if a fault causes excessive overheating internally, the system goes into overheating block.	Press the Reset button (1)
03	Flue safety thermostat block	During normal operation, if excessive flue gas overheating occurs due to an anomaly, the system goes into lockout.	Press the Reset button (1)
04	Contacts resistance block	The P.C.B. detects a fault on the gas valve supply. Check its connection. (the anomaly is detected and displayed only in the event of a request).	Press the Reset button (1)
05	Delivery probe fault	The board detects an anomaly on the flow NTC probe.	The system does not start (1)

(1) If the block or anomaly persists, contact an authorised company (e.g. Immergas Authorised After-Sales Centre)  
 (2) The anomaly can only be verified in the list of errors in the "Information" menu



Error Code	Anomaly signalled	Cause	UI Status/Solution
06	DHW probe fault	The board detects an anomaly on the domestic hot water NTC probe. In this case the antifreeze function is also inhibited	In this case the system continues to produce domestic hot water but not with optimal performance (1)
07	Chimney sweep function	Chimney sweep function active.	The central heating and domestic hot water production functions are not available until operation is completed.
08	Maximum N° of resets	Number of allowed resets already performed.	The anomaly can be reset 5 consecutive times, after which the function is inhibited for at least one hour and it is possible to try once every hour, for a maximum of 5 attempts. By switching the indoor unit on and off again, the 5 attempts are re-acquired
10	Insufficient system pressure	Sufficient water pressure inside the central heating circuit to guarantee the correct operation of the system is not detected.	Check on the indoor unit pressure gauge that the system pressure is between 1-1.2 bar and restore the correct pressure if necessary.
15	Configuration error	If the board detects an anomaly or incongruity on the electric wiring of the system and it will not start.	If normal conditions are restored, the system restarts without having to be reset. Check that the system is configured correctly (1)
16	Fan anomaly	This occurs if the fan has a mechanical or electrical fault.	Press the Reset button (1)
20	Parasite flame block	This occurs in the event of a leak on the detection circuit or anomaly in the flame control unit.	Press the Reset button (1)
23	Return probe anomaly	The board detects an anomaly on the return NTC probe	The system does not start (1)
24	Push button control panel anomaly	The board detects an anomaly on the pushbutton panel.	If normal conditions are restored, the system restarts without having to be reset (1).
(1) If the block or anomaly persists, contact an authorised company (e.g. Immergas Authorised After-Sales Centre)			
(2) The anomaly can only be verified in the list of errors in the "Information" menu			

Error Code	Anomaly signalled	Cause	UI Status/Solution
27	<b>Circulation insufficient</b>	This occurs if there is overheating in the system due to insufficient water circulating in the primary circuit; the causes can be: - low system circulation; check that no shut-off devices are closed on the central heating circuit and that the system is free of air (deaerated); circulating pump blocked; free the circulating pump.	Press the Reset button (1).
29	<b>Flue probe anomaly</b>	The board detects an anomaly on the flue probe.	The system does not start (1)
31	<b>Loss of remote control communication</b>	This occurs if an incompatible remote control is connected, or if communication between the system and control panel is lost	Disconnect and reconnect power to the system. If the control panel is still not detected at restart, the system will switch to local operating mode, i.e. using the controls on the control panel. In this case, the "Central Heating" (1) function cannot be activated.
37	<b>Low power supply voltage</b>	This occurs when the power supply voltage is lower than the allowed limits for correct system operation.	If normal conditions are restored, the system restarts without having to be reset (1)
38	<b>Loss of flame signal</b>	This occurs when the system is ignited correctly and the burner flame switches off unexpectedly; a new attempt at ignition is performed and if normal conditions are restored, the system does not have to be reset.	If normal conditions are restored, the system restarts without having to be reset (1) (2)
43	<b>Block due to loss of flame signal</b>	This occurs if the "Flame signal loss" error occurs many times in a row within a preset period (38).	Press the Reset button, before restarting, the system will run a post-ventilation cycle. (1)
44	<b>Block for exceeding gas valve frequent maximum opening time (if present)</b>	This occurs if the gas valve remains open for longer than required for normal operation, without the boiler switching on.	Press the Reset button (1)
(1) If the block or anomaly persists, contact an authorised company (e.g. Immergas Authorised After-Sales Centre)			
(2) The anomaly can only be verified in the list of errors in the "Information" menu			

INSTALLER

USER

CONTROL PANEL

MAINTENANCE TECHNICIAN

TECHNICAL DATA



Error Code	Anomaly signalled	Cause	UI Status / Solution
45	<b>ΔT high</b>	The system detects a sudden, unexpected increase in the ΔT between the flow probe and the system return probe.	The power of the burner is limited to prevent damage to the condensation module and once the right ΔT is restored, the system resumes regular operation. Make sure there is water circulating in the system, that the pump is configured according to system requirements and that the return probe works properly. (1)
47	<b>Burner power limitation</b>	Should flue high temperature be detected, the system reduces power supplied so as not to damage it.	(1)
60	<b>Anomaly pump blocked</b>	The pump is stopped due to one of the following causes: Impeller blocked, electrical fault.	Try to unblock the pump as described in the relative section. If normal conditions are restored, the system restarts without having to be reset (1)
61	<b>Air in circulator</b>	Air is detected inside the pump; the pump cannot work.	Vent the pump and the central heating circuit. If normal conditions are restored, the system restarts without having to be reset (1)
70	<b>Return/flow probe exchange</b>	In case of an incorrect system wiring connection the error is detected	The system does not start (1)
75	<b>Return and/or flow probe malfunction</b>	Possible failure of one or both system return and flow probes	The system does not start (1)
76	<b>Flow and/or return probes temperature drift</b>	A malfunction of one or both system return and flow probes is detected.	The system does not start (1)
(1) If the block or anomaly persists, contact an authorised company (e.g. Immergas Authorised After-Sales Centre)			
(2) The anomaly can only be verified in the list of errors in the “Information” menu			



### List of Outdoor Unit Anomalies

Error Code	Anomaly signalled	Cause	EU State/ Solution
1006	<b>Return probe anomaly</b>	Return probe anomaly	(1)
1008	<b>Delivery probe fault</b>	Delivery probe fault	(1)
1015	<b>Abnormal flow temperature increase (during DHW heating)</b>	Abnormal flow temperature increase (during DHW heating)	(1)
1016	<b>Abnormal flow temperature increase</b>	Abnormal flow temperature increase	(1)
1019	<b>System water overtemperature</b>	System water overtemperature	(1)
1020	<b>Power supply voltage anomaly</b>	Power supply voltage anomaly	(1)
1021	<b>High pressure anomaly</b>	High pressure anomaly	(1)
1022	<b>Overtemperature</b>	Overtemperature	(1)
1024	<b>DHW storage tank temperature rise</b>	DHW storage tank temperature rise	(1)
1026	<b>Maximum time heating domestic hot water storage tank</b>	Maximum time heating domestic hot water storage tank	(1)
1032	<b>Liquid probe anomaly</b>	Liquid probe anomaly	(1)
1036	<b>Control card fault</b>	Control card fault	(1)
1039	<b>High pressure switch fault</b>	High pressure switch fault	(1)
1040	<b>High pressure switch fault</b>	High pressure switch fault	(1)
1043	<b>Compressor overload</b>	Compressor overload	(1)
1044	<b>Compressor start anomaly</b>	Compressor start anomaly	(1)
(1) If the block or anomaly persists, contact an authorised company (e.g. Immergas Authorised After-Sales Centre)			
(2) The anomaly can only be verified in the list of errors in the “Information” menu			

INSTALLER

USER

CONTROL PANEL

MAINTENANCE TECHNICIAN

TECHNICAL DATA



Error Code	Anomaly signalled	Cause	EU State / Solution
1045	Fan anomaly	Fan anomaly	(1)
1046	Fan anomaly	Fan anomaly	(1)
1050	Compressor overcurrent anomaly	Compressor overcurrent anomaly	(1)
1053	Summer/winter switch fault	Summer/winter switch fault	(1)
1054	DHW accumulation temperature anomaly	DHW accumulation temperature anomaly	(1)
1057	Compressor supply voltage fault	Compressor supply voltage fault	(1)
1060	High pressure switch error	High pressure switch fault	(1)
1064	Compressor start anomaly	The compressor does not start up properly	(1)
1065	Compressor anomaly	Compressor power supply BUS not coherent	(1)
1066	Outside temperature probe failure	Outdoor air temperature sensor anomaly	(1)
1072	High discharge temperature	Compressor discharge temperature too high	(1)
1077	High external coil temperature	High temperature on external coil	(1)
1078	High pressure on external coil	Temperature too high on external coil	(1)
1079	Pressure sensor anomaly	Detected cooling gas pressure out of range	(1)
1080	Coolant pressure probe anomaly	Coolant pressure probe anomaly	(1)
1081	Discharge probe anomaly	Compressor discharge temperature sensor anomaly	(1)
1083	External coil probe anomaly	Outdoor coil temperature sensor anomaly	(1)
1103	High inverter temperature	Inverter board temperature too high	(1)
<p>(1) If the block or anomaly persists, contact an authorised company (e.g. Immergas Authorised After-Sales Centre)  (2) The anomaly can only be verified in the list of errors in the “Information” menu</p>			

Error Code	Anomaly signalled	Cause	EU State/ Solution
1104	<b>Inverter temperature increased abnormally</b>	Temperature on cooling fins too high	(1)
1105	<b>Inverter overcurrent</b>	Overcurrent detected on the inverter	(1)
1118	<b>Inverter probe failure</b>	Inverter temperature sensor anomaly	(1)
1119	<b>Coolant missing</b>	Lack of coolant in outdoor unit	(1)
1123	<b>Power supply voltage anomaly</b>	Power supply tension anomaly	(1)
1125	<b>Internal communication error</b>	Internal communication error	(1)
1126	<b>Internal communication error</b>	Internal communication error	(1)
1128	<b>Communication error with outdoor unit boards</b>	Inverter communication error - hydronic board	(1)
1135	<b>Internal communication error</b>	Internal communication error	(1)
(1) If the block or anomaly persists, contact an authorised company (e.g. Immergas Authorised After-Sales Centre)			
(2) The anomaly can only be verified in the list of errors in the “Information” menu			

INSTALLER

USER

CONTROL PANEL

MAINTENANCE TECHNICIAN

TECHNICAL DATA



# 4 INSTRUCTIONS FOR MAINTENANCE AND INITIAL CHECK

## 4.1 GENERAL RECOMMENDATIONS



Operators who install and service the appliance must wear the personal protective equipment (PPE) required by applicable law.  
The list of possible PPE is not complete as they are indicated by the employer.



Before carrying out any maintenance work, make sure that:

- you have disconnected the power to the appliance;
- you have closed the gas isolation valve;
- you have discharged the pressure from the system and domestic hot water circuit.



### Risk of material damage after using sprays and liquids to search for leaks

Leak sprays and liquids clog the reference hole P1. Ref. (Fig. 79) of the gas valve, damaging it irreparably.  
During installation and maintenance, do not use spray or liquids on the gas valve (electric connections side).



### Supply of spare parts

The device's warranty shall be rendered null and void if unapproved or unsuitable parts are used for maintenance or repairs. These will also compromise the product's compliance, and the said product may no longer be valid and fail to meet the current regulations. In regard to the above, only use original Immergas spare parts when replacing components.



If additional documentation needs to be consulted for extraordinary maintenance, contact the Authorised After-Sales Service.

## 4.2 INITIAL CHECK

### Commissioning the appliance requires you to:

- check the existence of the declaration of system conformity;
- make sure that the type of gas used corresponds to indoor unit settings;
- check connection to a 230V-50Hz power mains, correct L-N polarity and the earthing connection;
- make sure that all electrical connections between: indoor unit and control panel, outdoor unit and control panel were performed according to the available documentation and applicable regulations;
- check that all hydraulic connections between the indoor unit and the outdoor unit have been made in accordance with available documentation and applicable regulations;
- check the tightness of the hydraulic circuits;
- make sure the central heating system is filled with water and the cooling appliance pressure gauge reads a pressure of 1-1.2 bar;
- switch the appliance on and check correct ignition;
- check the proper calibration of the number of fan revolutions;
- check the CO<sub>2</sub>/O<sub>2</sub> in the flue gas at the flow rate:
  - maximum
  - minimum
- the values comply with the relevant tables (Par. 4.3);
- fill in and affix the installation information sticker on the appliance next to the data nameplate, with the same data as in this instruction manual (Par. 1.1) on the facsimile of the sticker;
- check activation of the safety device in the event of no gas, as well as the relative activation time;
- check the activation of the main switch located upstream of the appliance;
- check that the intake and/or exhaust terminals are not blocked;
- ensure activation of all adjustment devices;
- seal the gas flow regulation devices (if the settings are changed);
- ensure production of domestic hot water;
- check ventilation and/or aeration of the installation room where provided;
- check that there are no damaged components or crushed pipes in the outdoor unit;
- make sure that the shut-off valves are installed correctly and completely open;
- make sure that the air discharge valves are closed and the automatic air discharge valves are open;
- check the safety valves for water leaks, when they are open;
- check that the minimum water volume is guaranteed in all conditions;
- if glycol is used, make sure that the concentration is correct and set the related parameter on the control panel.



**Even if just one single safety check provides a negative result, do not commission the system.**

INSTALLER

USER

CONTROL PANEL

MAINTENANCE TECHNICIAN

TECHNICAL DATA



### 4.3 YEARLY APPLIANCE CHECK AND MAINTENANCE

#### On the indoor unit:

- Clean the flue side of the heat exchanger.
- Clean the main burner.
- Check the correct positioning, integrity and cleanliness of the detection and ignition electrode; remove any oxide present.
- If deposits are detected in the combustion chamber they must be removed and the heat exchanger coils must be cleaned using nylon or broomcorn brushes; it is forbidden to use brushes made of metal or other materials that may damage the combustion chamber. It is also forbidden to use alkaline or acid detergents.
- Check the integrity of the insulating panels inside the combustion chamber and if damaged replace them.
- Visually check for water leaks or oxidation from/on connections and traces of condensate residues inside the sealed chamber.
- Check the contents of the condensate drain trap.
- Visually check that the siphon is properly filled with condensate and top it up if necessary.
- Check that there are no material residues in the condensate drain siphon clogging the condensate passage; also check that the entire condensate drainage circuit is clear and efficient.
- In the event of obstructions (dirt, sediment, etc.) with consequent leakage of condensate in the combustion chamber, one must replace the insulating panels.
- Every time the gas manifold is opened, the condition and integrity of the ceramic fibres must be verified and replaced, if necessary. On the other hand, the gas manifold gasket must be replaced every 2 years and every time the manifold is opened, regardless of the time elapsed. After replacing the external silicone gasket, it is mandatory to check the fume tightness.
- Check that the burner is intact, that it has no deformations or cuts and that it is properly fixed to the gas manifold; otherwise it must be replaced. Visually check that the drain of the water safety valve is not clogged.
- Check that the charge of the expansion vessel is 1.0 bar, after having discharged the system pressure and bringing it to zero (readable on the pressure gauge of the appliance).
- Check that the system static pressure (with system cold and after refilling the system by means of the filling valve) is between 1 and 1.2 bar.
- Visually check that the safety and control devices have not been tampered with and/or short-circuited.
- Check the condition and integrity of the electrical system and in particular:
  - the power supply wires must be housed in the cable glands;
  - there must be no traces of blackening or burning.
- Check correct lighting and operation.
- Check the CO<sub>2</sub>/O<sub>2</sub> by using the chimney sweep function at the reference heat outputs, using the parameters entered in the following tables. Should values out of the indicated tolerance range be detected, check the calibration again.
- Check correct operation of control and adjustment devices and in particular:
  - system regulation probes intervention;
  - Domestic hot water control thermostat intervention.
- Check sealing efficiency of gas circuit and the internal system.
- Check the intervention of the device against no gas ionisation flame control. Intervention time must be less than 10 seconds.

INSTALLER

USER

CONTROL PANEL

MAINTENANCE TECHNICIAN

TECHNICAL DATA



**Victrix24HY**

Gastype	CO <sub>2</sub> to Nominal Q.	CO <sub>2</sub> to ignition Q.	CO <sub>2</sub> to Minimum Q.
G20	9,7 (9,5 ÷ 10,2) %	9,7 (9,5 ÷ 10,2) %	8,8 (8,5 ÷ 9,0) %
G31	11,4 (11,1 ÷ 11,5) %	11,4 (11,1 ÷ 11,5) %	10,6 (10,5 ÷ 10,9) %

Gastype	O <sub>2</sub> at Nominal Q.	O <sub>2</sub> at Ignition Q.	O <sub>2</sub> at Minimum Q.
G20	3,5 (3,9 ÷ 2,6) %	3,5 (3,9 ÷ 2,6) %	5,1 (5,7 ÷ 4,8) %

**Victrix32HY**

Gastype	CO <sub>2</sub> to Nominal Q.	CO <sub>2</sub> to ignition Q.	CO <sub>2</sub> to Minimum Q.
G20	9,5 (9,3 ÷ 9,7) %	9,5 (9,3 ÷ 9,7) %	8,6 (8,3 ÷ 8,8) %
G31	11,2 (10,8 ÷ 11,4) %	11,2 (10,8 ÷ 11,4) %	10,0 (9,8 ÷ 10,4) %

Gastype	O <sub>2</sub> at Nominal Q.	O <sub>2</sub> at Ignition Q.	O <sub>2</sub> at Minimum Q.
G20	3,9 (4,2 ÷ 3,5) %	3,9 (4,2 ÷ 3,5) %	5,5 (6,0 ÷ 5,1) %



If a Hydrogen ready installation is planned for H<sub>2</sub> percentages up to 20%, (referring to the gas distributed in the network according to local standards in force) all calibration of the unit must refer to the O<sub>2</sub> values in the table above.



In addition to yearly maintenance, one must also check the energy efficiency of the thermal system, with frequency and procedures that comply with the indications of the technical regulations in force.



When adjusting nominal heat input, if the O<sub>2</sub> values are not reached with the gas flow regulator completely open, no further adjustments are required.



In the case of an annual inspection of the device, the max CO must be less than 700 ppm (0% O<sub>2</sub>). If the CO value is higher, the device requires maintenance/repair.

INSTALLER

USER

CONTROL PANEL

MAINTENANCE TECHNICIAN

TECHNICAL DATA



**On the outdoor unit:**

Check the following points at least once per year:

- **External coil**

The external coil of the Audax.DK4 may be obstructed by dirt, dust, leaves, etc...

It is recommended to clean the coil when necessary (at least once a year) to avoid reaching too high or too low pressures that would decrease the performance of the outdoor unit.



- **Water filter**

Clean the system water filter.

Handle the water filter with care. Do not use excessive force when reinserting the water filter in order to avoid damaging the mesh of the filter.

- **Safety valve**

Visually check that the drain of the water safety valve is not clogged.

The points to be checked are:

- the flow rate of the safety valve is optimal;
- if there is dirty water coming from the safety valve:
  - open the valve until the discharged water no longer contains dirt;
  - wash the system and install an additional water filter (possibly a magnetic cycloidal filter).

We recommend performing this maintenance multiple times per year.

- **Electrical part**

Perform a visual check of the electrical part of the outdoor unit checking the electrical connections and the wiring.

In case of faults on the wiring or electrical connections, the replacement must be performed by qualified personnel (for example the Authorised Technical Assistance Centre).

- **Antifreeze protection valve**

Replace the antifreeze protection valve every 3-7 years (according to the quality of the water).

Replace the antifreeze protection valve if it does not close properly.

- **Vacuum breaker valve**

Disassemble the vacuum breaker valve and clean the cartridge with water.

Keep the area around the unit clean.



**The coolant inside the unit is slightly flammable.**

**If the refrigerant were to come out, coming into contact with the flame of a burner, a heater or a gas kitchen, it may cause a fire or form noxious gas.**

**Switch off the flammable heating devices, air the room and contact an authorised company (e.g. the Authorised Technical Assistance Centre).**

**DO NOT use the unit until a qualified technician has repaired the leaking component that is leaking coolant.**



- DO NOT perforate or burn the components of the coolant cycle.

- DO NOT use cleaning materials or tools to accelerate the defrosting process other than those recommended by the manufacturer.

- Keep in mind that the coolant in the system is odourless.

**Refrigerant gas recovery in case of leaks**

If you wish to recover the coolant gas in case of a leak in the circuit:



DO NOT use the automatic gas recovery function by means of "Pump down".

Possible consequence: self-combustion or explosion of the compressor due to air mixing with the flammable coolant.



Use a separate recovery system so that the compressor of the unit is NOT operated.



During the coolant recovery operation with the Pump Down, stop the compressor before removing the coolant piping. If the compressor is still operating and the stop valve is open during coolant recovery with the Pump Down, air will be sucked into the system. Due to the abnormal pressure in the coolant cycle, the compressor may brake and the unit may be damaged. The coolant recovery operation with the Pump Down extracts all the coolant from the hydronic unit and sends it to the compressor module.

1. Remove the cover of the liquid stop valve and the gas stop valve.
2. From the control panel, set the stand-by mode (⏸) and then access the "Service" -> "Manual" -> "Pump down" -> "On" menu.
3. After  $\pm 2$  minutes, close the liquid stop valve with a hex key.
4. Check that a vacuum was achieved on the pressure gauge.
5. After  $\pm 5$  minutes, close the gas shut-off valve and stop the Pump Down from the "Service" -> "Manual" -> "Pump down" -> "Off" menu.

INSTALLER

USER

CONTROL PANEL

MAINTENANCE TECHNICIAN

TECHNICAL DATA



## 4.4 HYDRAULIC DIAGRAM

INSTALLER

USER

CONTROL PANEL

MAINTENANCE TECHNICIAN

TECHNICAL DATA

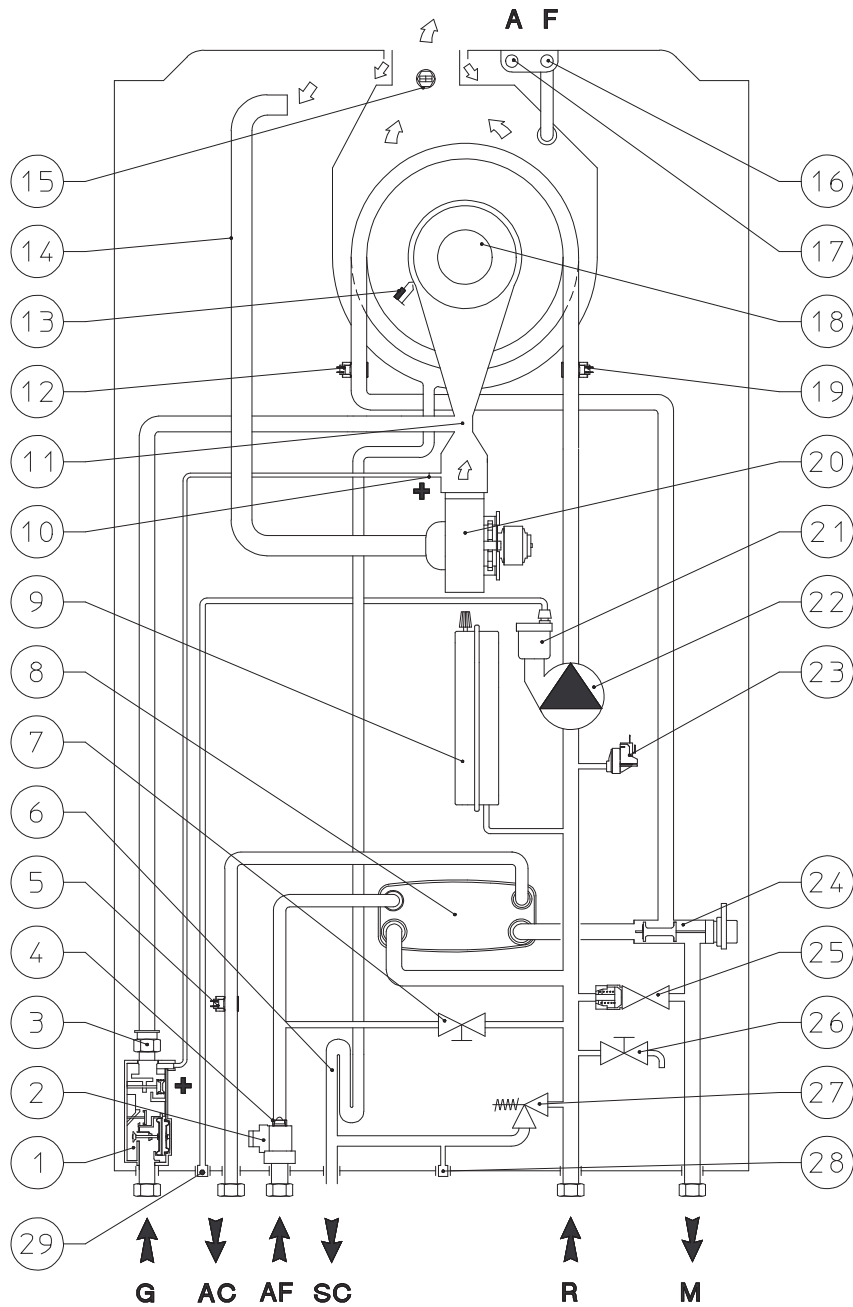

Key (Fig. 77):

1	- Gas valve	13	- Ignition / detection electrode	26	- System draining valve
2	- D.H.W. flow switch	14	- Air intake pipe	27	- 3 bar safety valve
3	- Gas nozzle	15	- Flue probe	28	- 3 bar safety valve drain fitting signal
4	- Flow limiter	16	- Flue sample point	29	- Air vent valve drain
5	- D.H.W. probe	17	- Air sample point		
6	- Condensate drain trap	18	- Burner	G	- Gas supply
7	- System filling valve	19	- Return probe	AC	- Domestic hot water outlet
8	- D.H.W. heat exchanger	20	- Fan	AF	- Domestic hot water inlet
9	- System expansion vessel	21	- Air vent valve	SC	- Condensate drain
10	- Positive (+) pressure point	22	- Boiler circulating pump	M	- System flow
11	- Venturi	23	- Absolute pressure switch	R	- System return
12	- Flow probe	24	- 3-way valve (motorised)		
		25	- By-pass		

77



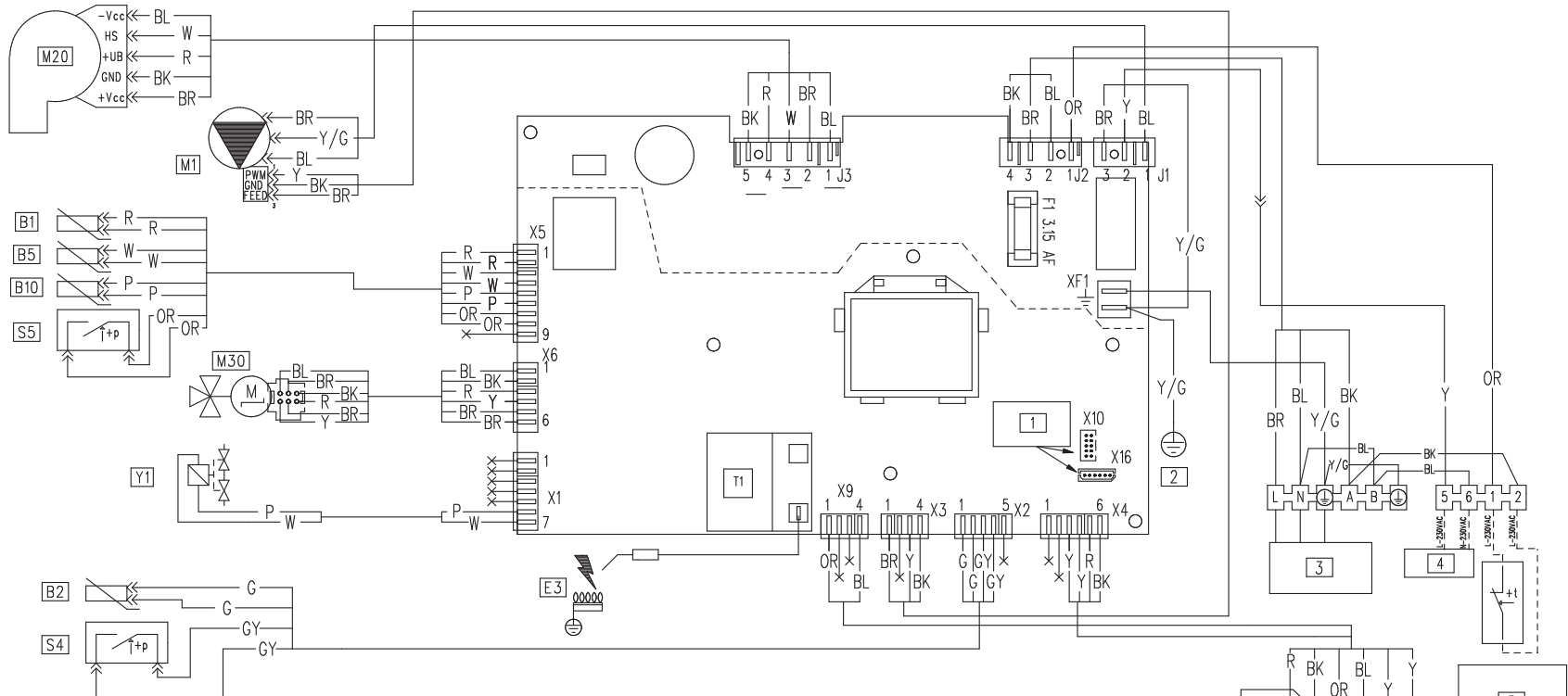

Key (Fig. 78):

- A23 - Audax.DK4 Outdoor Unit
- A33 - Victrix Hybrid control panel
- B1 - Flow probe
- B2 - D.H.W. probe
- B5 - Return probe
- B9 - DHW inlet probe (optional)
- B10 - Flue probe
- E3 - Ignition and detection electrode
- M1 - Outdoor unit circulator
- M20 - Fan
- M30 - Three-way stepper motor
- S4 - D.H.W. flow switch
- S5 - System pressure switch
- S20-230VAC - Room thermostat 230 VAC (optional)
- T1 - Ignition transformer
- Y1 - Gas valve

Colour code key (Fig. 78):

- BK - Black
- BL - Blue
- BR - Brown
- G - Green
- GY - Grey
- OR - Orange
- P - Purple
- PK - Pink
- R - Red
- W - White
- Y - Yellow
- G/Y - Yellow/Green
- 1 - Virgilio palmtop
- 2 - Frame earth
- 3 - 230Vac 50Hz power supply
- 4 - Configurable relay outlet
- 5 - Room thermostat 230Vac (Optional)
- 6 - Victrix Hybrid control panel
- 7 - Audax.DK4 Outdoor Unit

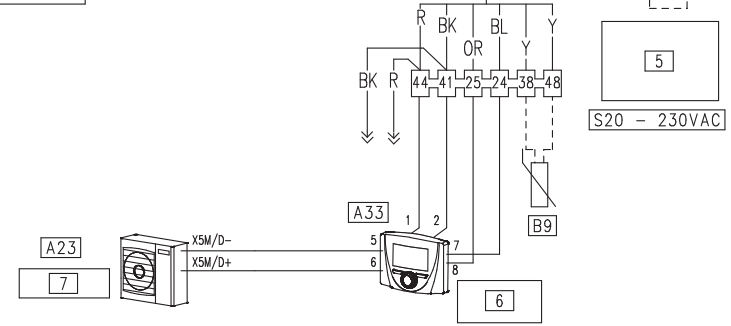

The connection of the room thermostat (S20) can only be made by always keeping the control panel connected with the room sensor disabled.  
The connection to the connection control panel is required for the hybrid heat pump to operate.



## 4.6 TROUBLESHOOTING



Maintenance operations must be carried out by an authorised company (e.g. Authorised After-Sales Technical Assistance Centre).

Trouble	Possible causes	Solutions
Smell of gas	Caused by leakage from gas circuit pipelines.	Check sealing efficiency of gas intake circuit.
Repeated ignition blocks	No gas. Condensate drain clogged.	Check the presence of pressure in the network and that the gas adduction valve is open. Restore the function of the condensate drain, checking that the condensate has not affected: combustion components, fan and gas valve.
Irregular combustion or noisiness	Dirty burner, clogged primary heat exchanger, incorrect combustion parameters, intake-exhaust terminal not correctly installed.	Check the indicated components.
Frequent trips of the overheating safety device thermostat function.	Lack of water in the appliance, little water circulation in the system or blocked pump (Parag. 1.40).	Check on the pressure gauge that the system pressure is within established limits. Check that the radiator valves are not closed and also the functionality of the pump.
Siphon blocked	Dirt or combustion products deposited inside.	Check that there are no residues of material blocking the flow of condensate.
Heat exchanger blocked.	This may be caused by the drain trap being blocked.	Check that there are no residues of material blocking the flow of condensate.
Abnormal noises in the system	Air in the system.	Check opening of the special air vent valve cap (Par.1.42). Make sure the system pressure and expansion tank factory-set pressure values are within the set limits. The factory-set pressure values of the expansion vessel must be 1.0 bar, the value of system pressure must be between 1 and 1.2 bar.
Abnormal noises in the condensation module	Air in the module.	Use the manual air vent valve (Parag. 1.42) to remove any air inside the condensation module. When the operation has been performed, close the manual air vent valve.
Poor production of D.H.W.	Clogged condensing module or D.H.W. exchanger.	Contact After-Sales Assistance Service that has procedures to clean the module or D.H.W. heat exchanger.

INSTALLER

USER

CONTROL PANEL

MAINTENANCE TECHNICIAN

TECHNICAL DATA



## 4.7 CONVERTING THE APPLIANCE TO OTHER TYPES OF GAS



The gas conversion operation must be carried out by an authorised company (e.g. Authorised Technical Assistance Service).

If the appliance needs to be converted to a different gas type to that specified on the data plate, request the relative conversion kit for quick and easy conversion.

To convert to another type of gas the following operations are required:

- Disconnect power to the appliance;
- Replace the nozzle (Det. 9, Fig. 54) taking care to disconnect the appliance during this operation;
- Re-power the appliance;
- Calibrate fan speed (Par. 4.8);
- Adjust the CO<sub>2</sub>/O<sub>2</sub> (Par. 4.9).
- Seal the gas flow rate regulation devices (if settings are modified);
- After completing the conversion, apply the sticker, contained in the conversion kit, on the data plate (Fig. 2) in the area relating to the type of gas. Using an indelible marker pen, delete the data relative to the old type of gas.

These adjustments must be made with reference to the type of gas used, following that given in the table (Parag. 5.2).

### PX42 Gas Valve

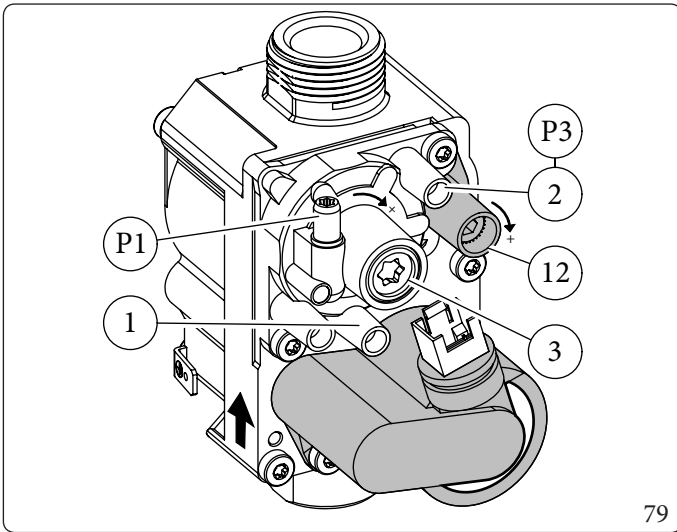

Key (Fig. 79):

- 1 - Gas valve inlet pressure point
- 2 - Gas valve outlet pressure point
- 3 - Off/Set adjustment screw
- 12 - Outlet gas flow rate adjuster

INSTALLER

USER

CONTROL PANEL

MAINTENANCE TECHNICIAN

TECHNICAL DATA



## 4.8 FAN SPEED CALIBRATION



Verification and calibration are necessary, in the case of transformation to other types of gas, in the extraordinary maintenance phase with replacement of the PCB, air/gas circuit components or in the case of installations with flue extraction systems, with horizontal concentric pipe measuring more than 1 metre.

The appliance's heat output is correlated to the length of the air intake and flue exhaust pipes.

This decreases with the increase of pipe length.

The appliance leaves the factory adjusted for minimum pipe length (1m coaxial).

- Activate flue test (Par. 3.12);
- Detect the flue signal  $\Delta P$  (Ref. 16 and 17, Fig.77);
- Compare the signal  $\Delta P$  and, if necessary, correct the S1 operating parameters with the following tables:

### Victrix24HY

	$\Delta P < 170 \text{ Pa}$	$\Delta P \geq 170 \text{ Pa}$	$\Delta P \geq 220 \text{ Pa}$
G20 (x50 = RPM)	S1 = 121	S1 = 123	S1 = 126
G31 (x50 = RPM)	S1 = 115	S1 = 118	S1 = 121

### Victrix32HY

	$\Delta P < 200 \text{ Pa}$	$\Delta P \geq 200 \text{ Pa}$	$\Delta P \geq 268 \text{ Pa}$
G20 (x50 = RPM)	S1 = 128	S1 = 131	S1 = 134
G31 (x50 = RPM)	S1 = 121	S1 = 124	S1 = 127



## 4.9 CO<sub>2</sub>/O<sub>2</sub> REGULATION



The verification operations of the CO<sub>2</sub>/O<sub>2</sub> must be carried out with the casing mounted, while the gas valve calibration operations must be carried out with the casing open and removing the voltage from the appliance.



The calibrations described below must be carried out in the correct sequence and more precisely, first the calibration of the CO<sub>2</sub>/O<sub>2</sub> at maximum output and then the calibration of the CO<sub>2</sub>/O<sub>2</sub> at minimum output.

### - PX42 Gas Valve

#### Calibration of the CO<sub>2</sub> at maximum output

Enter the chimney sweep mode without withdrawing DHW and set the output to maximum (99%).

To have an exact value of CO<sub>2</sub> in the flue, the technician must insert the sampling probe to the bottom of the sample point, then check that the CO<sub>2</sub> value is that specified in the table (Ref. Par. 5.2), otherwise adjust the screw (Part. 12, Fig. 79) (gas flow rate regulator).

To increase the CO<sub>2</sub> value, turn the adjustment screw (Part. 12, Fig. 79) clockwise and vice-versa to decrease it.

At every adjustment variation on the screw (Part. 12, Fig. 79), it is necessary to wait for the boiler to stabilise itself at the value set (about 30 sec.).

#### Calibration of the CO<sub>2</sub> at minimum output

After setting the CO<sub>2</sub> to maximum power while keeping the chimney sweep function active and without drawing domestic water, set the output to minimum (0%).

To have an exact value of CO<sub>2</sub> in the flue, the technician must insert the sampling probe to the bottom of the sample point, then check that the CO<sub>2</sub> value is that specified in the table (Ref. Parag. 5.2), otherwise adjust the screw (Part. 3, Fig. 79) (Offset regulator) after removing the cover cap.

To increase the CO<sub>2</sub> value, turn the adjustment screw (Part. 3, Fig. 79) clockwise and vice-versa to decrease it.



In the case where the calibration refers to O<sub>2</sub> the adjustment logic is reversed from the above for CO<sub>2</sub>.

## 4.10 CHECKS FOLLOWING CONVERSION TO ANOTHER TYPE OF GAS

After making sure that conversion was carried out with a nozzle of suitable diameter for the type of gas used and the settings are made at the correct pressure, check that the burner flame is not too high or low and is stable (does not detach from burner).



Maintenance operations must be carried out by an authorised company (e.g. Authorised After-Sales Technical Assistance Centre).

INSTALLER

USER

CONTROL PANEL

MAINTENANCE TECHNICIAN

TECHNICAL DATA



#### 4.11 SOLAR PANELS COUPLING

The device is set up to receive pre-heated water from a system of solar panels up to a maximum temperature of 65°C. In any case, it is always necessary to install a mixing valve on the hydraulic circuit upstream of the device, on the cold water inlet.

To optimise the operation, where the probe is not already fitted on the boiler, the solar inlet probe kit is available on request (see wiring diagram Fig. 78):

- If there is no probe kit, it is advisable to set parameter A6 (DHW thermostat) at "1";
- Otherwise, where the kit is installed or the probe is already present in the boiler, parameter A6 must be left at "0". This kit allows connecting a probe on the domestic cold water inlet pipe of the boiler to prevent unnecessary ignitions in systems with water heating through solar systems or alternative sources. The boiler will not turn on if the inlet water is sufficiently hot.

In both conditions (probe present or not), we recommend setting parameter t3 (solar delay timing) at a time sufficient to let the water inside the D.H.W. circuit upstream of the boiler drain.

The greater the distance from the storage tank, the longer wait time will have to be set.

With these adjustments made, when a domestic withdrawal is requested, once the time set on parameter "t3" has passed, if the water entering the boiler is at a temperature that is equal to or greater than that set, the boiler will not turn on.



For good functioning of the boiler; the temperature selected on the solar valve must be 5 °C greater with respect to the temperature selected on the boiler control panel.

#### 4.12 PUMP ANTI-BLOCK

The appliance has a function that starts up the pump at least once every 24 hours for 30 seconds in order to reduce the risk of the pump locking up due to prolonged inactivity.

#### 4.13 THREE-WAY ANTI-BLOCK

In both phase "DHW", and "DHW - Central heating", the appliance has a function that activates the motorised 3-way unit 24 hours after the last time it operated by running a complete cycle in order to reduce the risk of the 3-way blocking due to prolonged inactivity.

#### 4.14 RADIATOR ANTIFREEZE

If the system return water is below 4°C, the appliance starts up until reaching 42°C.

#### 4.15 AMBIENT ANTIFREEZE

When the room temperature drops below 5°C (adjustable, see special functions chapter) a central heating request is made at minimum of the power programmed.

This situation remains active until there is a variation in room temperature of 0.6°C equal to 5.6°C measured in the room where the control panel is positioned. The function is only active when the room control interface is set as Remote Panel (P. Rem.).





## 4.16 OPERATING LOGIC

### Central heating mode

Following a request during the room heating mode, the electronics decide, according to the external temperature, whether to activate the outdoor unit, or (with cold temperatures) the indoor unit (Fig. 81).

The management electronics select which heat source to be used according to the combination of the parameters set in the integration menu of the control panel. The indoor unit may activate when the external conditions are favourable to the operation of the outdoor unit; this may happen after a time proportional to the "Heat. waiting time" parameter.

Alternatively, a fixed outside switching temperature can be set (manual mode in parameter "Integration mode" by setting the temperature with "Manual activation temp."). The DHW demand is met by the indoor unit in priority mode over a possible space heating demand.

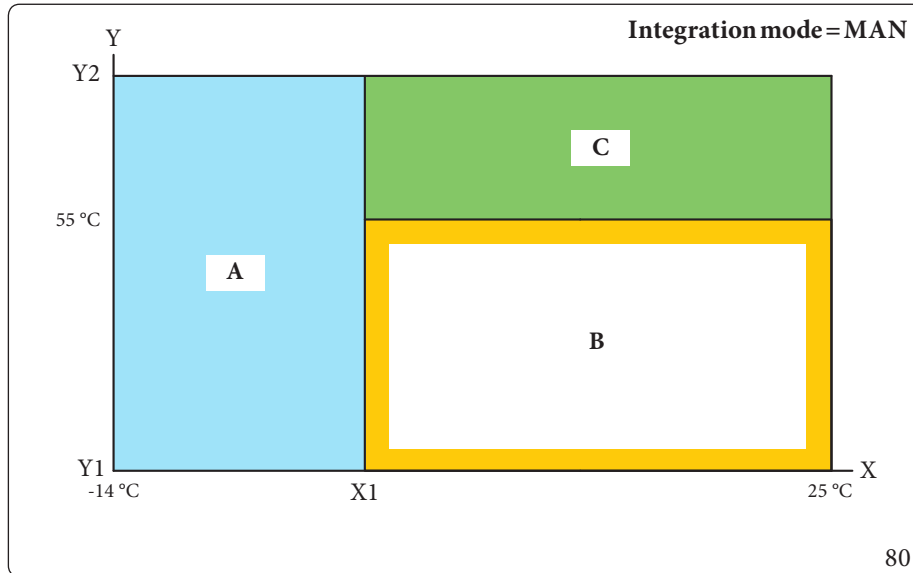

Key (Fig. 80 - 81):

- X - External temperature
- X1 - Integration activation temperature
- Y - Central heating/C.H. set
- Y1 - Minimum
- Y2 - Maximum
- A - Exclusive operation of the indoor unit
- B - **Outdoor unit operation.** When the activation time set by the user has elapsed, the indoor unit also starts
- C - Simultaneous operation 'with differentiated settings' (the outdoor unit will operate as a pre-heater of the indoor unit at a lower set point than the latter)

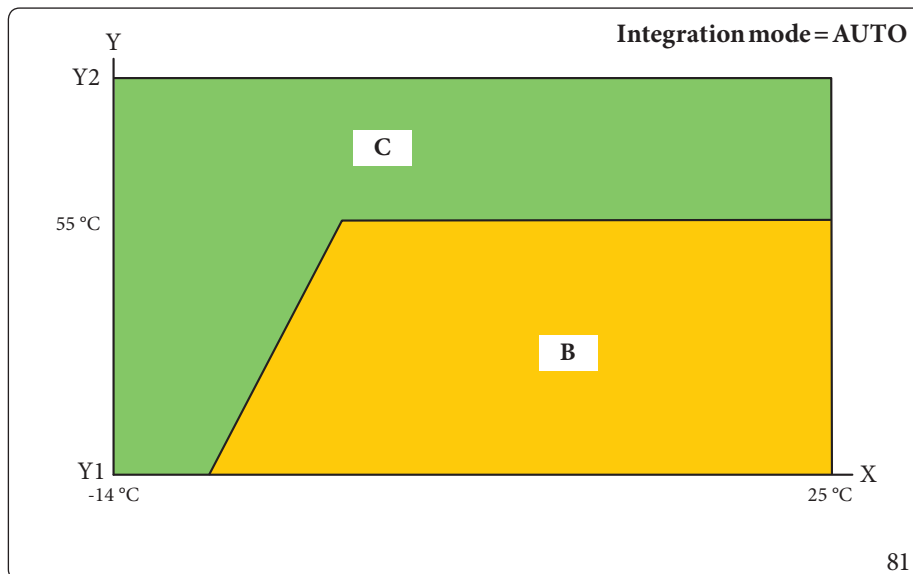

**i** If the automatic mode is activated, the outdoor unit will pre-heat the system to the temperature corresponding to the highest economic efficiency of the electric generator.



## 4.17 CASING REMOVAL

To facilitate appliance maintenance the casing can be completely removed as follows:

### Lower grid (Fig. 82)

1. Loosen the two screws (a).
2. Press the hooks inwards, which block the lower grid (b).
3. Remove the grid (b).

### Front panel (Fig. 83)

4. Open the door (e1), remove the cover caps (c) and loosen screws (d).
5. Pull the front panel (e) towards you and release it from its lower seat.

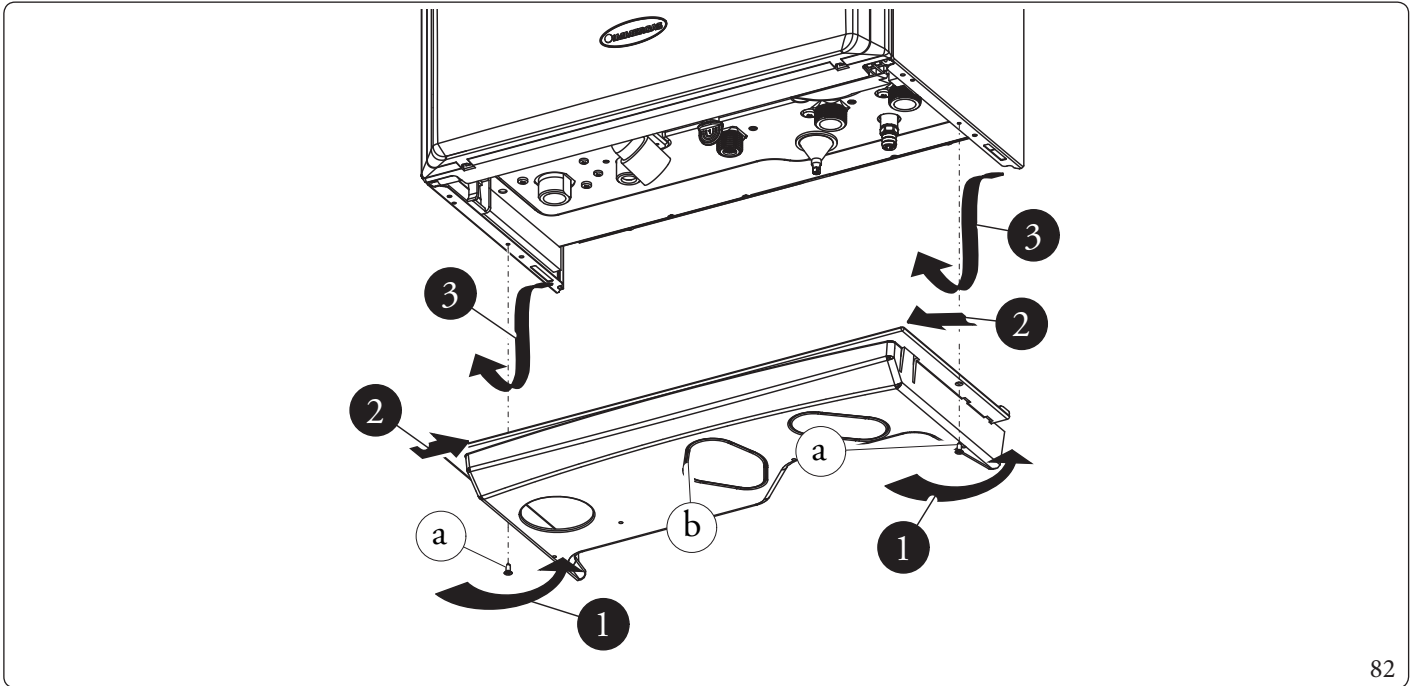

82

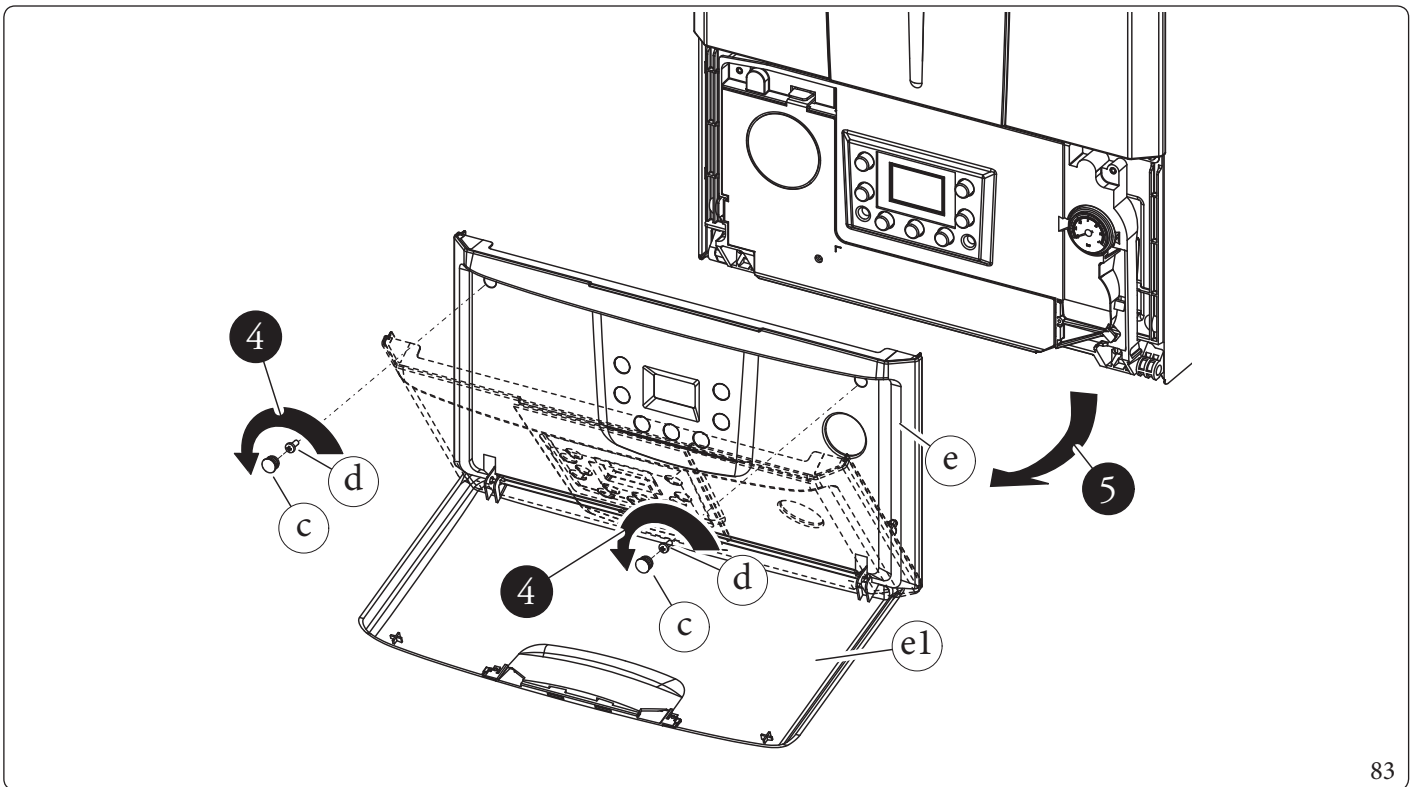

83

**Front (Fig.84)**

6. Loosen the two screws (g).
7. Pull the front (f) slightly towards you.
8. Release front (f) from pins (h) pulling it towards you while pushing it upwards at the same time.

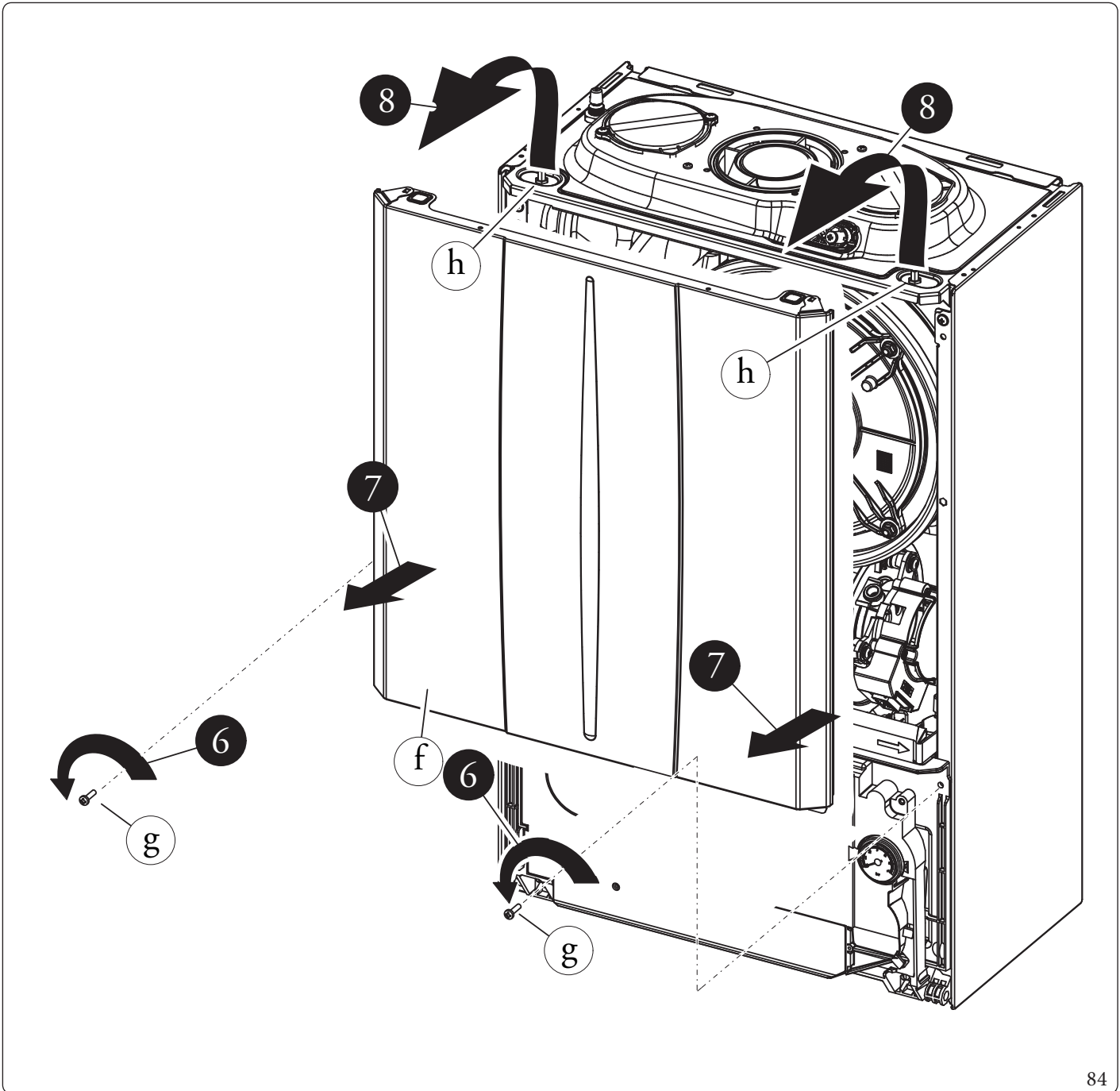

84

INSTALLER

USER

CONTROL PANEL

MAINTENANCE TECHNICIAN

TECHNICAL DATA



**Control panel (Fig. 85)**

- 9. Press the hooks on the side of the control panel (i).
- 10. Tilt the control panel (i) towards you.

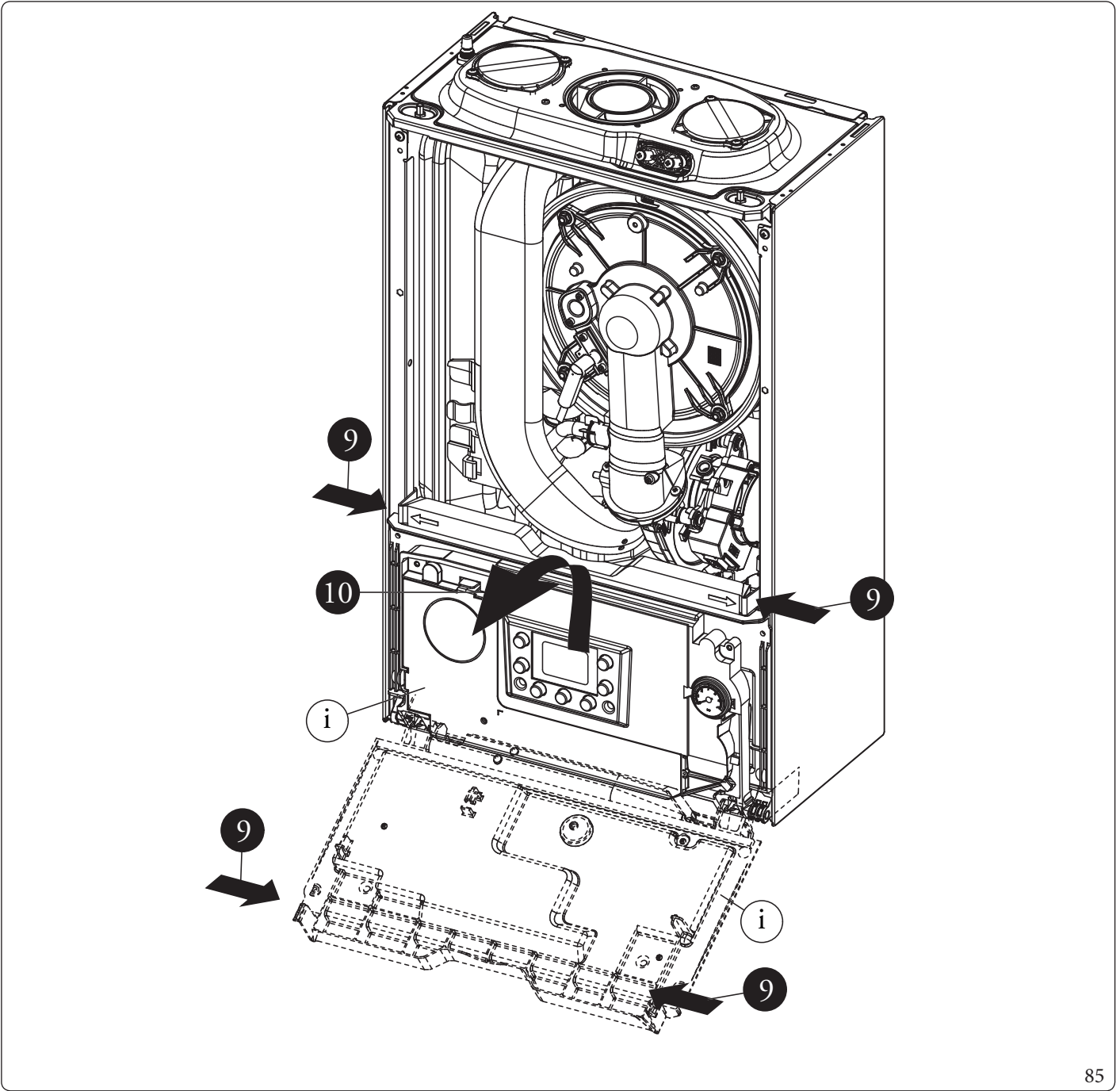

**Sides (Fig. 86)**

11. Loosen screws (k) of side fastening (j).

12. Remove the sides by extracting them from their rear seat (Ref. X).

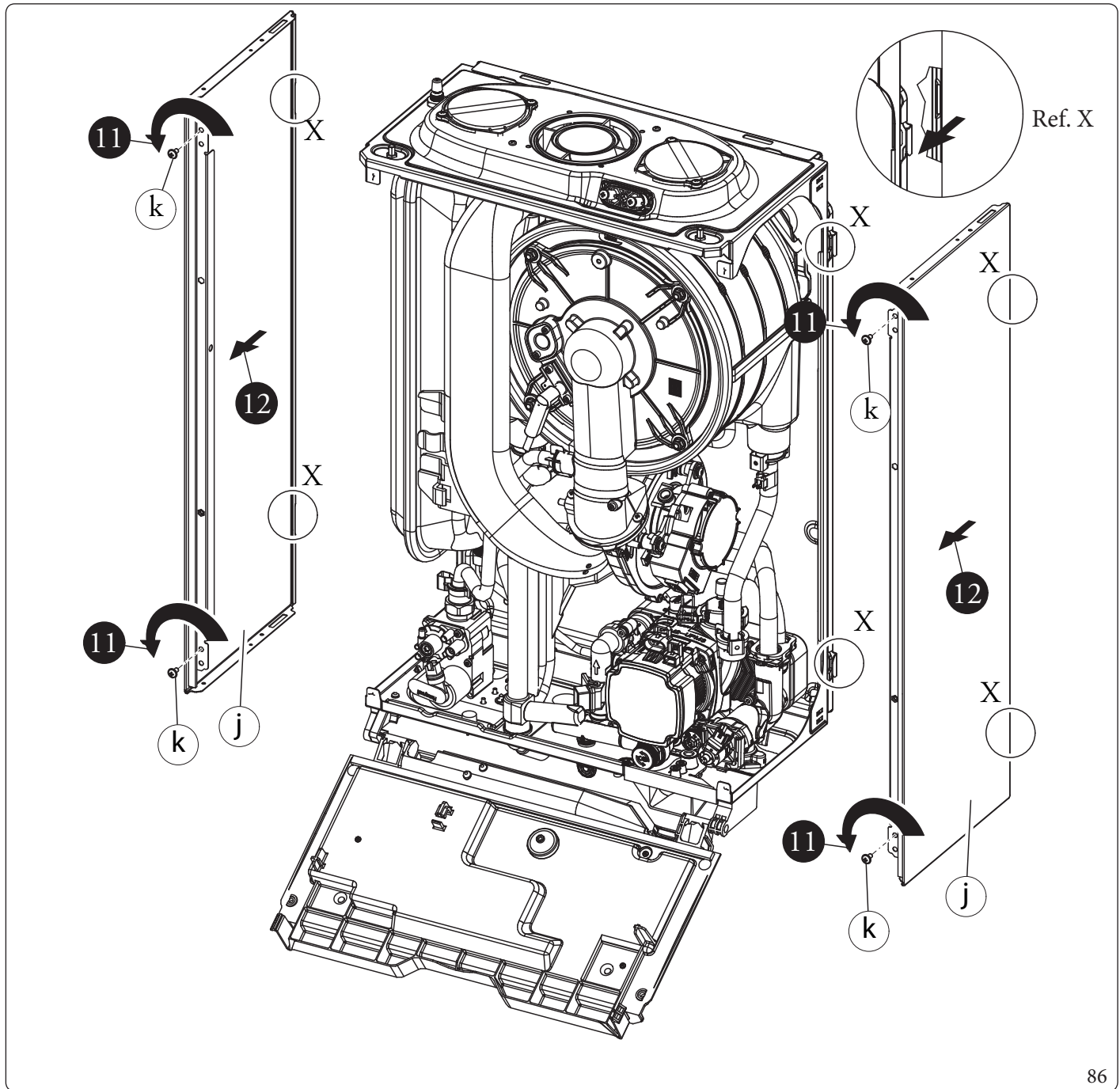

86

INSTALLER

USER

CONTROL PANEL

MAINTENANCE TECHNICIAN

TECHNICAL DATA



# 5 TECHNICAL DATA

## 5.1 VARIABLE HEAT OUTPUT



The power data in the table has been obtained with intake-exhaust pipe measuring 0.5 m in length. Gas flow rates refer to net calorific value below a temperature of 15°C and at a pressure of 1013 mbar.

### Victrix24HY

FLOW RATE OUTPUT	HEAT OUTPUT		METHANE (G20)			PROPANE (G31)		
			FANREVS		GASFLOW RATE BURNER	FANREVS		GASFLOW RATE BURNER
			(rpm)	(%)		(m³/h)	(rpm)	
28,8	28,3	D.H.W.	6050	100	3,05	5750	100	2,24
24,6	24,1	HEAT. + D.H.W.	5300	85	2,60	4950	82	1,91
23,5	23,0		5075	80	2,49	4750	78	1,83
22,0	21,5		4800	74	2,33	4475	71	1,71
21,0	20,5		4600	70	2,22	4300	67	1,63
19,5	19,0		4300	64	2,06	4025	61	1,51
18,5	18,1		4100	59	1,96	3850	57	1,44
17,0	16,6		3800	53	1,80	3575	51	1,32
16,0	15,6		3600	48	1,69	3400	47	1,24
14,6	14,2		3325	43	1,54	3125	41	1,13
13,5	13,1		3125	38	1,43	2925	37	1,05
12,0	11,6		2825	32	1,27	2650	30	0,93
11,0	10,6		2625	27	1,16	2475	26	0,85
9,5	9,2		2325	21	1,01	2200	20	0,74
8,5	8,2		2125	17	0,90	2025	16	0,66
7,0	6,7		1850	11	0,74	1750	10	0,54
6,0	5,7		1650	7	0,63	1575	6	0,47
4,5	4,3	1350	0	0,48	1300	0	0,35	

INSTALLER

USER

CONTROL PANEL

MAINTENANCE TECHNICIAN

TECHNICAL DATA



**Victrix32HY**

		METHANE (G20)			PROPANE (G31)			
FLOWRATE OUTPUT	HEAT OUTPUT		FANREVS		GASFLOW RATE BURNER	FANREVS		GASFLOW RATE BURNER
(kW)	(kW)		(rpm)	(%)	(m³/h)	(rpm)	(%)	(kg/h)
32,6	32,0	D.H.W.	6400	100	3,45	5950	100	2,53
28,6	28,0	HEAT.+ D.H.W.	5625	85	3,03	5250	85	2,22
27,0	26,4		5325	79	2,86	4975	79	2,10
25,5	24,9		5050	74	2,70	4725	74	1,98
24,0	23,5		4800	69	2,54	4475	68	1,86
22,5	22,0		4525	63	2,38	4250	63	1,75
21,5	21,0		4325	59	2,28	4075	59	1,67
20,0	19,5		4050	54	2,12	3825	54	1,55
18,5	18,0		3800	49	1,96	3575	49	1,44
16,9	16,4		3500	43	1,78	3300	43	1,31
15,5	15,1		3250	38	1,64	3075	38	1,20
14,0	13,6		2975	32	1,48	2825	32	1,09
12,5	12,1		2700	27	1,32	2575	27	0,97
11,0	10,6		2425	21	1,16	2325	21	0,85
9,5	9,1		2150	16	1,01	2075	16	0,74
8,0	7,7		1875	10	0,85	1825	10	0,62
6,5	6,2		1600	5	0,69	1575	5	0,50
5,1	4,9		1350	0	0,54	1350	0	0,40

INSTALLER

USER

CONTROL PANEL

MAINTENANCE TECHNICIAN

TECHNICAL DATA



## 5.2 COMBUSTION PARAMETERS

Combustion parameters: measuring conditions of useful efficiency (flow temperature/return temperature= 80/60 °C), ambient temperature reference = 20 °C.

### Victrix24HY

Gastype		G20	G31
Supply pressure	mbar	20,0	37,0
Gas nozzle diameter	mm	4,90	3,80
Ignition fan speed	rpm	2200	2200
Post ventilation fan speed	rpm	2200	2200
Flue flow rate at D.H.W. nominal heat output	kg/h	44	43
Flue flow rate at heating nominal heat output	kg/h	38	37
Flue flow rate at min heat output	kg/h	8	7
CO <sub>2</sub> at Nominal Q.	%	9,7 (9,5 ÷ 10,2)	11,4 (11,1 ÷ 11,5)
*O <sub>2</sub> at Nominal Q.		3,5 (3,9 ÷ 2,6)	- (- ÷ -)
CO <sub>2</sub> at Ignition Q.	%	9,7 (9,5 ÷ 10,2)	11,4 (11,1 ÷ 11,5)
*O <sub>2</sub> at Ignition Q.		3,5 (3,9 ÷ 2,6)	3,5 (4,0 ÷ 3,4)
CO <sub>2</sub> at Minimum Q.	%	8,8 (8,5 ÷ 9,0)	10,6 (10,5 ÷ 10,9)
*O <sub>2</sub> at Minimum Q.		5,1 (5,7 ÷ 4,8)	- (- ÷ -)
CO with 0% O <sub>2</sub> at Nom./Min. Q.	ppm	360/7	430/9
NO <sub>x</sub> with 0% O <sub>2</sub> at Nom./Min. Q.	mg/kWh	65/22	85/55
Flue temperature at nominal output	°C	72	73
Flue temperature at minimum output	°C	64	69
Max air combustion temperature	°C	50	50
Maximum flue gas circuit temperature	°C	120	120

When using H2NG mixtures with H<sub>2</sub> percentages up to 20% (referring to the gas distributed in the network), all calibration operations of the device must refer to the O<sub>2</sub> values of the G20 gas given in the following table.

### Victrix32HY

Gastype		G20	G31
Supply pressure	mbar	20,0	37,0
Gas nozzle diameter	mm	5,80	4,30
Ignition fan speed	rpm	2800	2800
Post ventilation fan speed	rpm	2800	2800
Flue flow rate at D.H.W. nominal heat output	kg/h	51	50
Flue flow rate at heating nominal heat output	kg/h	45	44
Flue flow rate at min heat output	kg/h	9	9
CO <sub>2</sub> at Nominal Q.	%	9,5 (9,3 ÷ 9,7)	11,2 (10,8 ÷ 11,4)
*O <sub>2</sub> at Nominal Q.		3,9 (4,2 ÷ 3,5)	- (- ÷ -)
CO <sub>2</sub> at Ignition Q.	%	9,5 (9,3 ÷ 9,7)	11,2 (10,8 ÷ 11,4)
*O <sub>2</sub> at Ignition Q.		3,9 (4,2 ÷ 3,5)	3,8 (4,4 ÷ 3,5)
CO <sub>2</sub> at Minimum Q.	%	8,6 (8,3 ÷ 8,8)	10,0 (9,8 ÷ 10,4)
*O <sub>2</sub> at Minimum Q.		5,5 (6,0 ÷ 5,1)	- (- ÷ -)
CO with 0% O <sub>2</sub> at Nom./Min. Q.	ppm	300/5	430/5
NO <sub>x</sub> with 0% O <sub>2</sub> at Nom./Min. Q.	mg/kWh	56/18	89/39
Flue temperature at nominal output	°C	75	75
Flue temperature at minimum output	°C	62	62
Max air combustion temperature	°C	50	50
Maximum flue gas circuit temperature	°C	120	120

When using H2NG mixtures with H<sub>2</sub> percentages up to 20% (referring to the gas distributed in the network), all calibration operations of the device must refer to the O<sub>2</sub> values of the G20 gas given in the following table.





### 5.3 INDOOR UNIT TECHNICAL DATA TABLE

		VICTRIX 24HY	VICTRIX 32HY
Domestic hot water nominal heat input	kW	28,8	32,6
Central heating nominal heat input	kW	24,6	28,6
Minimum heat input	kW	4,5	5,1
DHW nominal heat input with 20% H <sub>2</sub> NG gas	kW	26,4	31,3
Po Central heating nominal heat input with 20% H <sub>2</sub> NG gas	kW	22,6	27,0
Minimum heat input with 20% H <sub>2</sub> NG gas	kW	4,4	4,9
Domestic hot water nominal heat output (useful)	kW	28,3	32,0
Central heating nominal heat output (useful)	kW	24,1	28,0
Minimum heat output (useful)	kW	4,3	4,9
*Effective thermal efficiency 80/60 Nom./Min.	%	97,8/95,5	97,9/95,5
*Effective thermal efficiency 50/30 Nom./Min.	%	106,1/106,1	106,0/108,2
*Effective thermal efficiency 40/30 Nom./Min.	%	108,2/108,3	107,9/108,2
Room central heating seasonal energy efficiency (η <sub>s</sub> )	%	93	
Casing losses with burner On/Off (80-60°C)	W	99/25	99/29
Chimney losses with burner On/Off (80-60°C)	W	6,3/517	6,3/572
Central heating circuit max. operating pressure	bar	3,0	
Maximum heating temperature	°C	90	
System expansion vessel total volume	l	4,9	5,1
Expansion vessel pre-charged pressure	bar	1,0	
Appliance water content	l	2,2	2,4
Flow rate capacity in continuous duty (ΔT 30°C)	l/min	14,1	16,5
Weight of full boiler	kg	38,9	41,4
Weight of empty boiler	kg	33,6	35,5
Electrical connection	V/Hz	230/50	
Nominal absorbed current	A	0,6	0,9
Installed electric power	W	80	115
Equipment electrical system protection	IP	X5D	
Ambient operating temperature range	°C	-5 ÷ 40	
Ambient operating temperature range with optional antifreeze kit	°C	-15 ÷ 40	
NO <sub>x</sub> class	-	6	
*Weighted NO <sub>x</sub> G20	mg/kWh	35	30
Weighted CO G20	mg/kWh	20	15
Type of flue installation	-	B <sub>23</sub> B <sub>33</sub> B <sub>53p</sub> C <sub>13</sub> C <sub>33</sub> C <sub>43</sub> C <sub>53</sub> C <sub>63</sub> C <sub>83</sub> C <sub>93</sub> C <sub>13X</sub> C <sub>33X</sub> C <sub>43X</sub> C <sub>83X</sub> C <sub>93X</sub>	
Market		IE	
Category		II2H3P	

The data relevant to domestic hot water performance refer to a dynamic inlet pressure of 2 bar and an inlet temperature of 15°C; the values are measured directly at the appliance outlet considering that to obtain the data declared mixing with cold water is necessary.

\* Efficiencies and weighted NO<sub>x</sub> refer to the net calorific value.

For type C<sub>63</sub> it is forbidden to install the appliance as it came out of the factory, in configurations that require shared flues in positive pressure.

INSTALLER

USER

CONTROL PANEL

MAINTENANCE TECHNICIAN

TECHNICAL DATA



## 5.4 OUTDOOR UNIT TECHNICAL DATA TABLE

The data shown below refer to the Audax.DK4 outdoor unit.

		VICTRIX HYBRID	VICTRIX HYBRID 32
<b>Nominal data for low temperature applications*</b>			
Nominal central heating output	kW		3,83
Absorption	kW		0,85
COP			4,49
<b>Nominal data for intermediate temperature applications (A35/W7)**</b>			
Nominal central heating output	kW		3,80
Absorption	kW		1,15
COP			3,30
<b>Nominal data for medium temperature applications*</b>			
Nominal central heating output	kW		3,28
Absorption	kW		1,29
COP			2,56

\* Central heating mode status: heat exchanger water inlet/remains at 30 °C/35 °C, outdoor air temperature 7 °C db/6 °C wb. Performance in compliance with EN 14511.

\* Central heating mode status: heat exchanger water inlet/remains at 40 °C/45 °C, outdoor air temperature 7 °C db/6 °C wb.

\*\*\* Central heating mode status: inlet/remains at 47 °C/55 °C, outdoor air temperature 7 °C db/6 °C wb. Performance in compliance with EN 14511.

### Outdoor unit data.

		VICTRIX HYBRID	VICTRIX HYBRID 32
Ambient operating temperature range	°C		-14 ... +35
Water content	l		2
Central heating circuit maximum operating pressure	bar		4
Minimum installation temperature	°C		-25
Electrical connection	Vac		220-240
Power supply frequency	Hz		50
Maximum input	A		10,3
Electric plant protection	-		IPX4
Empty outdoor unit weight	kg		45
Full outdoor unit weight	kg		47
Type of refrigerant	-		R-32
Quantity of refrigerant	g		560
GWP	-		675
tCO <sub>2</sub> eq	-		0.38
Ps Max	Mpa		4,17
Ps Min	Mpa		2,76

INSTALLER

USER

CONTROL PANEL

MAINTENANCE TECHNICIAN

TECHNICAL DATA



## Product data

		VICTRIX HYBRID	VICTRIX HYBRID 32
Produced water temperature (central heating)	°C	+20 ... +80	
Produced water temperature (DHW)	°C	+30 ... +60	
Ambient operating temperature (central heating)	°C	-25 ... +40	
Ambient operating temperature (DHW)	°C	-25 ... +40	
Minimum circulation flow rate	l/h	500	
Primary side water content	l	2,2 (UI) + 2(UE)	2,4 (UI) + 2(UE)
System expansion vessel volume	l	5,8	6,4
System expansion vessel pre-charging	bar	1,0	
Central heating circuit maximum operating pressure	kPa	300	
Maximum heating circuit operating temperature	°C	90	
Available head (1000l/h)	kPa	40,0	37,0
Domestic hot water circuit min. dynamic pressure	kPa	0,3	
Max. DHW circuit operating pressure	kPa	100	
Max. DHW circuit operating temperature	°C	90	

INSTALLER

USER

CONTROL PANEL

MAINTENANCE TECHNICIAN

TECHNICAL DATA



## 5.5 PRODUCT FICHE (IN COMPLIANCE WITH REGULATION 811/2013)

### VictrixHybrid

A	Supplier's name or trademark		-	Immergas S.p.A
	Supplier's model identifier		-	VICTRIX HYBRID
C	For space heating	Application temperature	-	Average temperature
	For water heating	Stated load profile	-	XL
D	Seasonal energy efficiency class of room heating	Average temperature	-	A++
		Low temperature	-	A++
	Energy efficiency class of water heating		-	A
E	Nominal heat output (average climate condition)	Average temperature	kW	6
		Low temperature	kW	5
F	Annual energy consumption for room heating (average climate condition)	Average temperature	kWh	3530
		Low temperature	kWh	2586
	Annual energy consumption for water heating (average climate condition)		kWh	27
G	Seasonal energy efficiency of room heating (average climate condition)	Average temperature	%	128
		Low temperature	%	163
	Energy efficiency of water heating (average climate condition)		%	87
H	Lwa sound power level indoors		dB	52
I	Operation only during dead hours		-	No
J	Specific precautions		-	-
K	Nominal heat output (colder climate condition)	Average temperature	kW	6
		Low temperature	kW	-
	Nominal heat output (warmer climate condition)	Average temperature	kW	5
		Low temperature	kW	-
L	Annual energy consumption for room heating (colder climate condition)	Average temperature	kWh	4755
		Low temperature	kWh	-
	Annual energy consumption for room heating (warmer climate condition)	Average temperature	kWh	1662
		Low temperature	kWh	-
	Annual energy consumption for water heating (colder climate condition)		kWh	-
	Annual energy consumption for water heating (warmer climate condition)		kWh	-
M	Seasonal energy efficiency of room heating (colder climate condition)	Average temperature	%	122
		Low temperature	%	-
	Seasonal energy efficiency of room heating (warmer climate condition)	Average temperature	%	158
		Low temperature	%	-
N	Lwa sound power level outdoors		dB	59

INSTALLER

USER

CONTROL PANEL

MAINTENANCE TECHNICIAN

TECHNICAL DATA



**Average temperature table (47/55) average zones**

Model	VICTRIXHYBRID						
Air/water heat pump	YES	Low temperature heat pump				NO	
Water/water heat pump	NO	With Supplementary heater				YES	
Brine/water heat pump	NO	Mixed central heating device with heat pump:				YES	
The parameters are declared for average temperature application, except for low temperature heat pumps. The parameters for low temperature heat pumps are declared for low temperature application							
The parameters are declared for average climatic conditions							
Element	Symbol	Value	Unit	Element	Symbol	Value	Unit
Nominal heat output	$P_{nomi-nale}$	6	kW	Room central heating seasonal energy efficiency	$\eta_s$	128	%
Central heating capacity declared with a partial load and indoor temperature equivalent to 20°C and outdoor temperature $T_j$				Performance coefficient declared with indoor temperature equivalent to 20°C and outdoor temperature $T_j$			
$T_j = -7\text{ °C}$	Pdh	-	kW	$T_j = -7\text{ °C}$	COPd	-	-
$T_j = +2\text{ °C}$	Pdh	3,0	kW	$T_j = +2\text{ °C}$	COPd	3,19	-
$T_j = +7\text{ °C}$	Pdh	3,2	kW	$T_j = +7\text{ °C}$	COPd	4,52	-
$T_j = +12\text{ °C}$	Pdh	3,9	kW	$T_j = +12\text{ °C}$	COPd	6,42	-
$T_j = T_{fb,off}$	Pdh	3,0	kW	$T_j = \text{bivalent temperature}$	COPd	3,19	-
$T_j = T_{hp,on}$	Pdh	2,5	kW	$T_j = \text{operating limit temperature}$	COPd	2,49	-
for air/water heat pumps: $T_j = -15\text{ °C}$ (se $T_{hp,on} < -20\text{ °C}$ )	Pdh	-	kW	for air/water heat pumps: $T_j = -15\text{ °C}$ (se TOL < -20 °C)	COPd	-	-
Bivalent temperature	$T_{fb,off}$	2	°C	HP operating limit temperature	$T_{hp,on}$	-3	°C
Central heating capacity cycle intervals	$P_{psych}$	-	kW	Cycle intervals efficiency	COP <sub>psych</sub>	-	-
Degradation coefficient	$C_{dh}$	1,0	-	Water heating temperature operating limit	WTOL	48	°C
Different mode of energy consumption from the active mode				Supplementary heater			
OFF mode	$P_{OFF}$	0,015	kW	Nominal heat output	$P_{sup}$	-	kW
Thermostat mode off	$P_{TO}$	0,015	kW	Type of energy supply voltage	gas		
Standby mode	$P_{SB}$	0,015	kW				
Guard heating mode	$P_{CK}$	0,000	kW				
Other items							
Capacity control	Variable			For air/water heat pumps: nominal air output to outside	-	1698	m³/h
Indoor/outdoor sound level	$L_{WA}$	52/59	dB	For water or brine/water heat pumps: nominal flow of brine or water, outdoor heat exchanger	-	-	m³/h
Annual energy consumption	$Q_{HE}$	3530	kWh or GJ				
For mixed central heating appliances with a heat pump							
Stated load profile	-			Water central heating energy efficiency	$\eta_{wh}$	-	%
Daily electrical power consumption	$Q_{elec}$	-	kWh	Daily fuel consumption	$Q_{fuel}$	-	kWh
Annual energy consumption	AEC	-	kWh	Annual fuel consumption	AFC	-	GJ
Contact information	Immergas S.p.A. via Cisa Ligure n.95						

INSTALLER

USER

CONTROL PANEL

MAINTENANCE TECHNICIAN

TECHNICAL DATA



**Victrix Hybrid 32**
**INSTALLER**
**USER**
**CONTROL PANEL**
**MAINTENANCE TECHNICIAN**
**TECHNICAL DATA**

A	Supplier's name or trademark		-	Immergas S.p.A
B	Supplier's model identifier		-	VICTRIX HYBRID 32
C	For space heating	Application temperature	-	Average temperature
	For water heating	Stated load profile	-	XL
D	Seasonal energy efficiency class of room heating	Average temperature	-	A++
		Low temperature	-	A++
	Energy efficiency class of water heating		-	A
E	Nominal heat output (average climate condition)	Average temperature	kW	6
		Low temperature	kW	5
F	Annual energy consumption for room heating (average climate condition)	Average temperature	kWh	3527
		Low temperature	kWh	2584
	Annual energy consumption for water heating (average climate condition)		kWh	29
G	Seasonal energy efficiency of room heating (average climate condition)	Average temperature	%	128
		Low temperature	%	163
	Energy efficiency of water heating (average climate condition)		%	87
H	Lwa sound power level indoors		dB	55
I	Operation only during dead hours		-	No
J	Specific precautions		-	-
K	Nominal heat output (colder climate condition)	Average temperature	kW	6
		Low temperature	kW	-
	Nominal heat output (warmer climate condition)	Average temperature	kW	5
		Low temperature	kW	-
L	Annual energy consumption for room heating (colder climate condition)	Average temperature	kWh	4750
		Low temperature	kWh	-
	Annual energy consumption for room heating (warmer climate condition)	Average temperature	kWh	1661
		Low temperature	kWh	-
	Annual energy consumption for water heating (colder climate condition)		kWh	-
Annual energy consumption for water heating (warmer climate condition)		kWh	-	
M	Seasonal energy efficiency of room heating (colder climate condition)	Average temperature	%	122
		Low temperature	%	-
	Seasonal energy efficiency of room heating (warmer climate condition)	Average temperature	%	158
		Low temperature	%	-
N	Lwa sound power level outdoors		dB	59



**Average temperature table (47/55) average zones**

Model	VICTRIXHYBRID 32						
Air/water heat pump	YES	Low temperature heat pump				NO	
Water/water heat pump	NO	With Supplementary heater				YES	
Brine/water heat pump	NO	Mixed central heating device with heat pump:				YES	
The parameters are declared for average temperature application, except for low temperature heat pumps. The parameters for low temperature heat pumps are declared for low temperature application							
The parameters are declared for average climatic conditions							
Element	Symbol	Value	Unit	Element	Symbol	Value	Unit
Nominal heat output	$P_{nomi-nale}$	6	kW	Room central heating seasonal energy efficiency	$\eta_s$	128	%
Central heating capacity declared with a partial load and indoor temperature equivalent to 20°C and outdoor temperature $T_j$				Performance coefficient declared with indoor temperature equivalent to 20°C and outdoor temperature $T_j$			
$T_j = -7\text{ °C}$	Pdh	-	kW	$T_j = -7\text{ °C}$	COPd	-	-
$T_j = +2\text{ °C}$	Pdh	3,0	kW	$T_j = +2\text{ °C}$	COPd	3,19	-
$T_j = +7\text{ °C}$	Pdh	3,2	kW	$T_j = +7\text{ °C}$	COPd	4,52	-
$T_j = +12\text{ °C}$	Pdh	3,9	kW	$T_j = +12\text{ °C}$	COPd	6,42	-
$T_j = T_{fb,off}$	Pdh	3,0	kW	$T_j = \text{bivalent temperature}$	COPd	3,19	-
$T_j = T_{hp,on}$	Pdh	2,5	kW	$T_j = \text{operating limit temperature}$	COPd	2,49	-
for air/water heat pumps: $T_j = -15\text{ °C}$ (se $T_{hp,on} < -20\text{ °C}$ )	Pdh	-	kW	for air/water heat pumps: $T_j = -15\text{ °C}$ (se TOL $< -20\text{ °C}$ )	COPd	-	-
Bivalent temperature	$T_{fb,off}$	2	°C	HP operating limit temperature	$T_{hp,on}$	-3	°C
Central heating capacity cycle intervals	$P_{psych}$	-	kW	Cycle intervals efficiency	$COP_{cyc}$	-	-
Degradation coefficient	$C_{dh}$	1,0	-	Water heating temperature operating limit	WTOL	48	°C
Different mode of energy consumption from the active mode				Supplementary heater			
OFF mode	$P_{OFF}$	0,015	kW	Nominal heat output	$P_{sup}$	-	kW
Thermostat mode off	$P_{TO}$	0,015	kW	Type of energy supply voltage	gas		
Standby mode	$P_{SB}$	0,015	kW				
Guard heating mode	$P_{CK}$	0,000	kW				
Other items							
Capacity control	Variable			For air/water heat pumps: nominal air output to outside	-	1698	$m^3/h$
Indoor/outdoor sound level	$L_{WA}$	55 / 59	dB	For water or brine/water heat pumps: nominal flow of brine or water, outdoor heat exchanger	-	-	$m^3/h$
Annual energy consumption	$Q_{HE}$	3527	kWh or GJ				
For mixed central heating appliances with a heat pump							
Stated load profile	-			Water central heating energy efficiency	$\eta_{wh}$	-	%
Daily electrical power consumption	$Q_{elec}$	-	kWh	Daily fuel consumption	$Q_{fuel}$	-	kWh
Annual energy consumption	AEC	-	kWh	Annual fuel consumption	AFC	-	GJ
Contact information	Immergas S.p.A. via Cisa Ligure n.95						

INSTALLER

USER

CONTROL PANEL

MAINTENANCE TECHNICIAN

TECHNICAL DATA



## 5.6 PARAMETERS FOR FILLING IN THE PACKAGE FICHE

If you wish to install an assembly, starting from this appliance, use the assembly charts in (Fig. 88).

For correct compilation, enter in the appropriate spaces (as shown in the facsimile overview sheet Fig. 87) the values given in the tables in the paragraph "Parameters to fill in the average temperature package fiche (47/55)".

The remaining values must be obtained from the technical data sheets of the products used to make up the assembly (e.g. solar devices, integration heat pumps, temperature controllers).

Use board (Fig. 88) for "assemblies" related to the central heating mode (e.g.: heat pump + temperature controller).



Since the product is standard supplied with a temperature controller, the package fiche must always be completed.

### Facsimile for filling in the package fiche for room central heating systems.

Room central heating seasonal energy efficiency of the heat pump

%

Temperature control  
From temperature  
control board

Class I = 1 %, Class II = 2 %,  
Class III = 1.5 %, Class IV = 2 %,  
Class V = 3 %, Class VI = 4 %,  
Class VII = 3.5 %, Class VIII = 5 %

+  %

Supplementary boiler  
From boiler board

Seasonal central heating energy efficiency of the room (%)

(  - 'I' ) x "II" = -  %

Solar contribution

From the board of the solar device

Dimensions of the manifold (in m<sup>2</sup>)

Volume of the tank (in m<sup>3</sup>)

Efficiency of the manifold (in %)

Classification of the tank  
A\* = 0.95, A = 0.91,  
B = 0.86, C = 0.83,  
D-G = 0.81

( 'III' x  + 'IV' x  ) x 0.45 x (  / 100 ) x  = +  %

Room central heating seasonal energy efficiency of the assemble in average climate conditions

%

Room central heating seasonal energy efficiency class of the assemble in average climate conditions

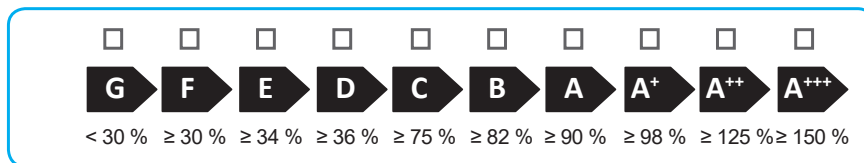

Room central heating seasonal energy efficiency in colder and hotter climate conditions

Colder:  - 'V' =  %

Hotter:  + 'VI' =  %

The energy efficiency of the set of products indicated in this sheet may not reflect the actual energy efficiency after installation since such efficiency is affected by additional factors, such as the heat loss in the distribution system and the size of the products compared to the size and features of the building.





Parameters to fill in the average temperature package fiche (47/55)

**VictrixHybrid**

Parameter	Colder zones	Average zones	Hotter zones
	■	■	■
"I"	122	128	158
"II"	*	*	*
"III"	4,45	4,77	5,35
"IV"	1,74	1,87	2,09

\* to be determined according to Regulation 811/2013 and transient calculation methods as per Notice of the European Community no. 207/2014.

Parameter	VictrixHybrid
"VI"	Remote control class supplied by default

**VictrixHybrid32**

Parameter	Colder zones	Average zones	Hotter zones
	■	■	■
"I"	122	128	158
"II"	*	*	*
"III"	4,45	4,77	5,35
"IV"	1,74	1,87	2,09

\* to be determined according to Regulation 811/2013 and transient calculation methods as per Notice of the European Community no. 207/2014.

Parameter	VictrixHybrid32
"VI"	Remote control class supplied by default

INSTALLER

USER

CONTROL PANEL

MAINTENANCE TECHNICIAN

TECHNICAL DATA



Room central heating system package fiche.

Room central heating seasonal energy efficiency of the heat pump

%

Temperature control  
From temperature  
control board

Class I = 1 %, Class II = 2 %,  
Class III = 1.5 %, Class IV = 2 %,  
Class V = 3 %, Class VI = 4 %,  
Class VII = 3.5 %, Class VIII = 5 %

+  %

Supplementary boiler  
From boiler board

Seasonal central heating energy efficiency of the room (%)

(  - \_\_\_\_\_ ) x \_\_\_\_\_ = -  %

*Solar contribution*

*From the board of the solar device*

Dimensions of the manifold (in m<sup>2</sup>)

Volume of the tank (in m<sup>3</sup>)

Efficiency of the manifold (in %)

Classification of the tank  
A\* = 0.95, A = 0.91,  
B = 0.86, C = 0.83,  
D-G = 0.81

( \_\_\_\_\_ x  + \_\_\_\_\_ x  ) x 0.45 x (  / 100 ) x  = +  %

Room central heating seasonal energy efficiency of the assemble in average climate conditions

%

Room central heating seasonal energy efficiency class of the assemble in average climate conditions

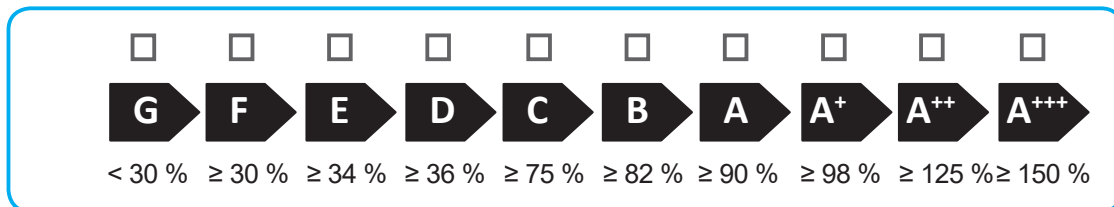

Room central heating seasonal energy efficiency in colder and hotter climate conditions

Colder:  - \_\_\_\_\_ =  %

Hotter:  + \_\_\_\_\_ =  %

*The energy efficiency of the set of products indicated in this sheet may not reflect the actual energy efficiency after installation since such efficiency is affected by additional factors, such as the heat loss in the distribution system and the size of the products compared to the size and features of the building.*





**Immergas S.p.A.**  
42041 Brescello (RE) - Italy  
Tel. 0522.689011  
[immergas.com](http://immergas.com)



**IMMERGAS**  
IMMERGASPA-ITALY  
CERTIFIED COMPANY  
UNI EN ISO 9001:2015

Design, manufacture and post-sale  
assistance of gas boilers, gas water heaters  
and related accessories



This instruction booklet is made of  
ecological paper.

