

MANUAL
USERS

Instructions and warnings **IE**
Installer
User
Maintenance technician

1.048849ENG



MINI EOLO 24 3E



CONTENTS

Dear Customer.....	4	2.4	Ignition of the boiler.....	31
General warnings	4	2.5	Fault and anomaly signals.	32
Safety symbols used.....	5	2.6	Information Menu.	33
Personal protective equipment.	5	2.7	Boiler shutdown.....	34
1 Boiler installation.....	6	2.8	Restore central heating system pressure.	34
1.1 Installation recommendations.	6	2.9	Draining the system.	34
1.2 Main dimensions.	9	2.10	Anti-freeze protection.....	34
1.3 Minimum installation distances.	9	2.11	Draining the domestic hot water circuit.....	34
1.4 Antifreeze protection.	10	2.12	Cleaning the case.	34
1.5 Boiler connection group (Optional).	10	2.13	Decommissioning.....	34
1.6 Gas connection.	11	3	Instructions for maintenance and initial check.	35
1.7 Hydraulic connection.....	12	3.1	General warnings.....	35
1.8 Electrical connection.....	12	3.2	Initial check.	35
1.9 Remote controls and room chrono-thermostats (Optional).....	13	3.3	Yearly appliance check and maintenance.	36
1.10 External temperature probe (Optional).....	14	3.4	Boiler Hydraulic diagram.	37
1.11 Immergas flue systems.	15	3.5	Wiring diagram.....	38
1.12 Tables of resistance factors and equivalent lengths.	17	3.6	Possible problems and their causes.	39
1.13 Outdoor installation in partially protected area.....	18	3.7	Converting the boiler to other types of gas.....	40
1.14 Concentric horizontal kit installation.....	19	3.8	Programming the P.C.B.	41
1.15 Concentric vertical kit installation.....	20	3.9	Possible adjustments.....	43
1.16 Separator kit installation.....	21	3.10	Automatic slow ignition function with timed ramp delivery.	43
1.17 Flue exhaust to flue/chimney.....	24	3.11	"Chimney sweep" function.	43
1.18 Ducting of flues or technical slots.	24	3.12	Pump anti-block function.	43
1.19 Configuration for C6 flue installation.....	24	3.13	Three-way anti-block system.....	43
1.20 Flues, chimneys and chimney caps.	25	3.14	Radiators anti-freeze function.	43
1.21 System filling.	25	3.15	P.C.B. periodical self-check.	43
1.22 Gas system start-up.	25	3.16	Solar panels coupling function.	44
1.23 Boiler start up (ignition).....	25	3.17	Casing removal.....	44
1.24 Circulation pump.....	26	4	Technical data.....	46
1.25 Kits available on request.	26	4.1	Variable heat output.	46
1.26 Boiler components.....	27	4.2	Combustion parameters.	46
2 Instructions for use and maintenance.....	28	4.3	Technical data.....	47
2.1 General warnings.....	28	4.4	Key for Data nameplate.....	48
2.2 Cleaning and maintenance.....	30			
2.3 Control panel.....	30			

Dear Customer,

Congratulations for having chosen a top-quality Immergas product, able to assure well-being and safety for a long period of time. As an Immergas customer you can also count on a Qualified Technical Assistance Centre, prepared and updated to guarantee constant efficiency of your appliance. Read the following pages carefully: you will be able to draw useful tips on the proper use of the device, compliance with which will confirm your satisfaction with the Immergas product.

For any assistance and scheduled maintenance please contact Authorised After-Sales centres: they have original spare parts and are specifically trained by the manufacturer.

General warnings

This book contains important information for the:

Installer (section 1);

User (section 2);

Maintenance Technician (section 3).

- The user must carefully read the instructions in the specific section (section 2).
- The user must limit operations on the appliance only to those explicitly allowed in the specific section.
- **Every operation carried out on the heat pump (e.g. set up, inspection, installation and commissioning), must mandatorily be performed by authorised personnel alone and in possession of a technical engineering or professional degree qualifying them to perform these tasks. They must also have attended a refresher course acknowledged by competent authorities. This particularly applies to personal specialised in C.H. and air-conditioning systems and qualified electricians who, due to their specialised training, skills and experience are experts in the correct installation and maintenance of C.H., cooling and air-conditioning systems.**
- The appliance must be installed by qualified and professionally trained personnel.
- The instruction booklet is an integral and essential part of the product and must be given to the new user in the case of transfer or succession of ownership.
- It must be stored with care and consulted carefully, as all of the warnings provide important safety indications for installation, use and maintenance stages.
- In compliance with legislation in force, the systems must be designed by qualified professionals, within the dimensional limits established by the Law. Installation and maintenance must be performed in compliance with the regulations in force, according to the manufacturer's instructions and by professionally qualified staff, intended as staff with specific technical skills in the system sector, as envisioned by the Law.
- Improper installation or assembly of the Immergas appliance and/or components, accessories, kits and devices can cause unexpected problems for people, animals and objects. Read the instructions provided with the product carefully to ensure proper installation.
- This instructions manual provides technical information for installing Immergas products. As for the other issues related to the installation of products (e.g. safety at the workplace, environmental protection, accident prevention), it is necessary to comply with the provisions of the standards in force and the principles of good practice.
- All Immergas products are protected with suitable transport packaging.
- The material must be stored in a dry place protected from the weather.
- Damaged products must not be installed.
- Maintenance must be carried out by skilled technical staff that represents a guarantee of qualifications and professionalism.
- The appliance must only be destined for the use for which it has been expressly declared. Any other use will be considered improper and therefore potentially dangerous.
- If errors occur during installation, operation and maintenance, due to non-compliance with technical laws in force, standards or instructions contained in this book (or however supplied by the manufacturer), the manufacturer is excluded from any contractual and extra-contractual liability for any damage and the appliance warranty is invalidated.
- In the event of malfunctions, faults or incorrect operation, turn the appliance off and contact an authorised company (e.g. the Authorised Technical Assistance Centre, which has specifically trained staff and original spare parts). Do not attempt to modify or repair the appliance alone.



Product not intended for EU countries

The manufacturer declines all liability due to printing or transcription errors, reserving the right to make any modifications to its technical and commercial documents without forewarning.

Safety symbols used.



GENERIC HAZARD

Strictly follow all of the indications next to the pictogram. Failure to follow the indications can generate hazard situations resulting in possible harm to the health of the operator and user in general.



ELECTRICAL HAZARD

Strictly follow all of the indications next to the pictogram. The symbol indicates the appliance's electrical components or, in this manual, identifies actions that can cause an electrical hazard.



MOVING PARTS

The symbol indicates the appliance's moving components that can cause hazards.



HOT SURFACES

The symbol indicates the appliance's very hot components that can cause burns.



SHARP SURFACES

The symbol indicates the appliance's components or parts that can cause cuts if touched.



EARTH TERMINAL CONNECTION

The symbol identifies the appliance's earth terminal connection point.

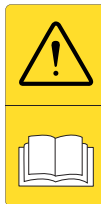

READ AND UNDERSTAND THE INSTRUCTIONS

Read and understand the appliance's instructions before performing any operation, carefully following the indications provided.



INFORMATION

Indicates useful tips or additional information.



The user must not dispose of the appliance at the end of its service life as municipal waste, but send it to appropriate collection centres.

Personal protective equipment.



SAFETY GLOVES



SAFETY GOGGLES



SAFETY FOOTWEAR

1 BOILER INSTALLATION.

1.1 Installation recommendations.

ATTENTION:

operators who install and service the appliance must wear the personal protective equipment required by applicable law.



This boiler has been designed for wall-mounted installation only; for central heating and production of domestic hot water for domestic use and similar purposes.



The place of installation of the appliance and relative Immergas accessories must have suitable features (technical and structural), such as to allow for (always in safe, efficient and comfortable conditions):

- installation (according to the provisions of technical legislation and technical regulations);
- maintenance operations (including scheduled, periodic, routine and special maintenance);
- removal (outdoors in the place for loading and transporting the appliances and components) as well as their eventual replacement with appliances and/or equivalent components.

The wall surface must be smooth, without any protrusions or recesses enabling access to the rear part. They are not designed to be installed on plinths or floors (Fig. 1).

By varying the type of installation the classification of the boiler also varies, precisely:

- **Type B₂₂ boiler:** if installed without the 2 intake caps and with the top cover kit.
- **Type C boiler:** if installed using concentric pipes or other types of pipes envisioned for the sealed chamber boiler for intake of air and expulsion of flue gas.

Only professionally qualified companies are authorised to install Immergas gas appliances.

Installation must be carried out according to regulation standards, current legislation and in compliance with local technical regulations and the required technical procedures.

ATTENTION:

It is not permitted to install boilers that are removed and decommissioned from other systems. The manufacturer declines all liability for damage caused by boilers removed from other systems or for any non-conformities of such equipment.

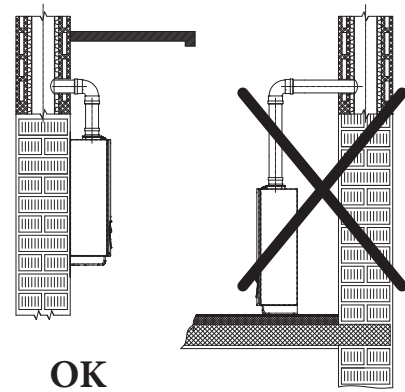

OK

1

ATTENTION:

check the environmental operating conditions of all parts relevant to installation, referring to the values shown in the technical data table in this booklet.



ATTENTION:

Installation of the boiler when powered by LPG must comply with the rules regarding gases with a greater density than air (remember, as an example, that it is prohibited to install plants powered with the above-mentioned gas in rooms where the floor is at a lower quota than the country level).



ATTENTION:

if installing a kit or servicing the appliance, always empty the system's domestic hot water circuit first so as not to compromise the appliance's electrical safety (Par. 2.9 and 2.11).



Before installing the appliance, ensure it has been delivered in perfect condition; if in doubt, contact the supplier immediately. Packing materials (staples, nails, plastic bags, polystyrene foam, etc.) constitute a hazard and must be kept out of the reach of children.

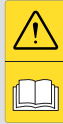

If the appliance is installed inside or between cabinets, ensure sufficient space for normal servicing; for the minimum installation distances refer to Fig. 3.

It is just as important that the intake grids and exhaust terminals are not obstructed.

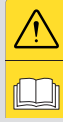

It is recommended to check that no flue gas recirculation is found in the air sample points (0.5% maximum permitted CO₂).

Keep all flammable objects away from the appliance (paper, rags, plastic, polystyrene, etc.).

The minimum distance for exhaust pipes from flammable materials must be at least 25 cm.

Do not place household appliances underneath the boiler as they could be damaged if the safety valve intervenes (if not conveyed away by a draining funnel), or if there are leaks from the hydraulic connections; otherwise, the manufacturer cannot be held responsible for any damage caused to the household appliances.

For the aforementioned reasons, we recommend not placing furnishings, furniture, etc. under the boiler.

In the event of malfunctions, faults or incorrect operation, turn the appliance off immediately and contact an authorised company (e.g. the Authorised Technical Assistance centre, which has specifically trained staff and original spare parts). Do not attempt to modify or repair the appliance alone.

Any modification to the appliance that is not explicitly indicated in this section of the booklet is forbidden.

Installation Standards:



- **This boiler can be installed outdoors in a partially protected area. A partially protected area is one in which the appliance is not exposed to the direct action of the weather (rain, snow, hail, etc.).**
- **Installation in places with a fire risk is prohibited (for example: garages, closed parking stalls), gas appliances and relative flue ducts, flue exhaust pipes and combustion air intake pipes.**

- **Installation on the vertical projection of cooking hobs is forbidden.**

- **Installation is also prohibited in places/ environments that constitute common parts of office condominiums such as stairs, cellars, entrance halls, attics, lofts, escape routes, etc. if they are not located inside technical compartments under the responsibility of each individual building and only accessible to the user (for the features of the technical compartments, see the technical standards in force).**

- **These boilers are not suitable for installation on walls made of combustible material.**

N.B.: wall mounting of the boiler must guarantee stable and efficient support for the boiler. The plugs (standard supply) are only to be used to fix the boiler to the wall; they only ensure adequate support if inserted correctly (according to technical standards) in walls made of solid or semi-hollow brick or block.



In the case of walls made of hollow bricks or blocks, partitions with limited static properties, or in any case walls other than those indicated, a static test must be carried out on the mounting system.

The hex head screws supplied in the blister pack are to be used exclusively to fix the relative mounting bracket to the wall



These boilers are used to heat water to below boiling temperature in atmospheric pressure.

They must be connected to a central heating system and domestic hot water circuit suited to their performance and capacity.



They cannot be connected directly to low-temperature systems.

Risk of damage due to corrosion caused by unsuitable combustion air and environment.

Spray, solvents, chlorine-based detergents, paints, glue, ammonium compounds, powders and similar cause product and flue duct corrosion.

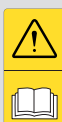

- Check that combustion air power supply is free from chlorine, sulphur, powders, etc.
- Make sure that no chemical substances are stored in the place of installation.
- If you want to install the product in beauty salons, paint workshops, carpenter's shop, cleaning companies or similar, choose a separate installation area that ensures combustion air supply that is free from chemical substances.
- Make sure the combustion air is not fed from chimneys that were used with gas boilers or other heating devices. In fact, these may cause an accumulation of soot in the chimney.

ATTENTION:

- Type B open chamber boilers must not be installed in places where commercial, artisan or industrial activities take place, which use products that may develop volatile vapours or substances (e.g. acid vapours, glues, paints, solvents, combustibles, etc.), as well as dusts (e.g. dust deriving from the working of wood, coal fines, cement, etc.), which may be harmful for the components of the appliance and jeopardise operation.
- in B configuration, unless otherwise provided for by local regulations in force: the boilers must not be installed in bedrooms, bathrooms or bedsits. They must neither be installed in rooms containing solid fuel heat generators nor in rooms communicating with said rooms.
- The installation rooms must be permanently ventilated, in compliance with the local regulations in force (at least 6 cm² for every kW of installed heat input, except in the event of any increases needed for electro-mechanical vacuum cleaners or other devices that could put the installation room under vacuum).
- The installation of appliances in configuration B is only recommended outdoors (in a partially protected place) or in places that are not lived in and which are permanently ventilated.

ATTENTION:

Failure to comply with the above implies personal responsibility and invalidates the warranty.



1.2 Main dimensions.

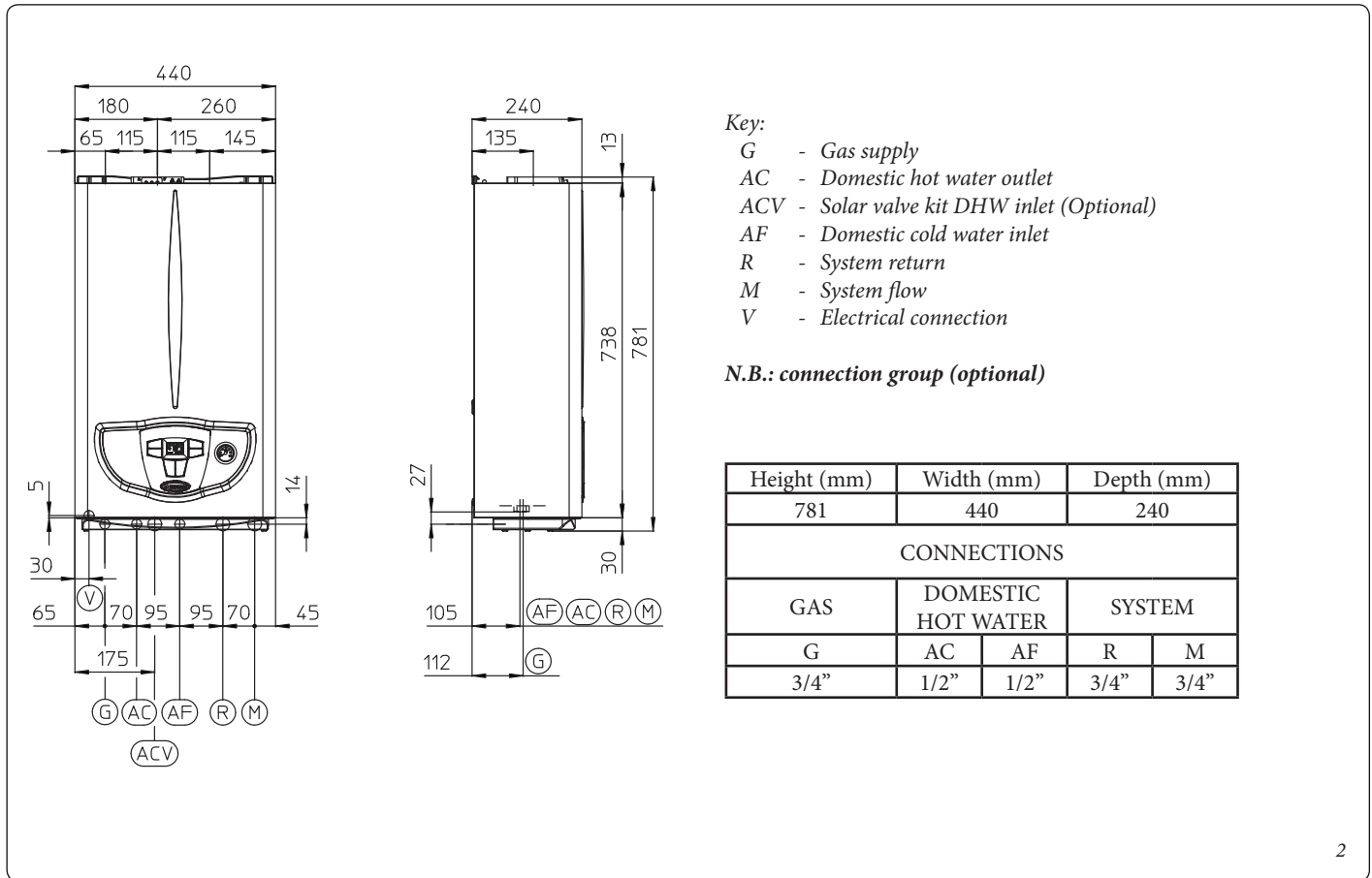

INSTALLER

USER

1.3 Minimum installation distances.

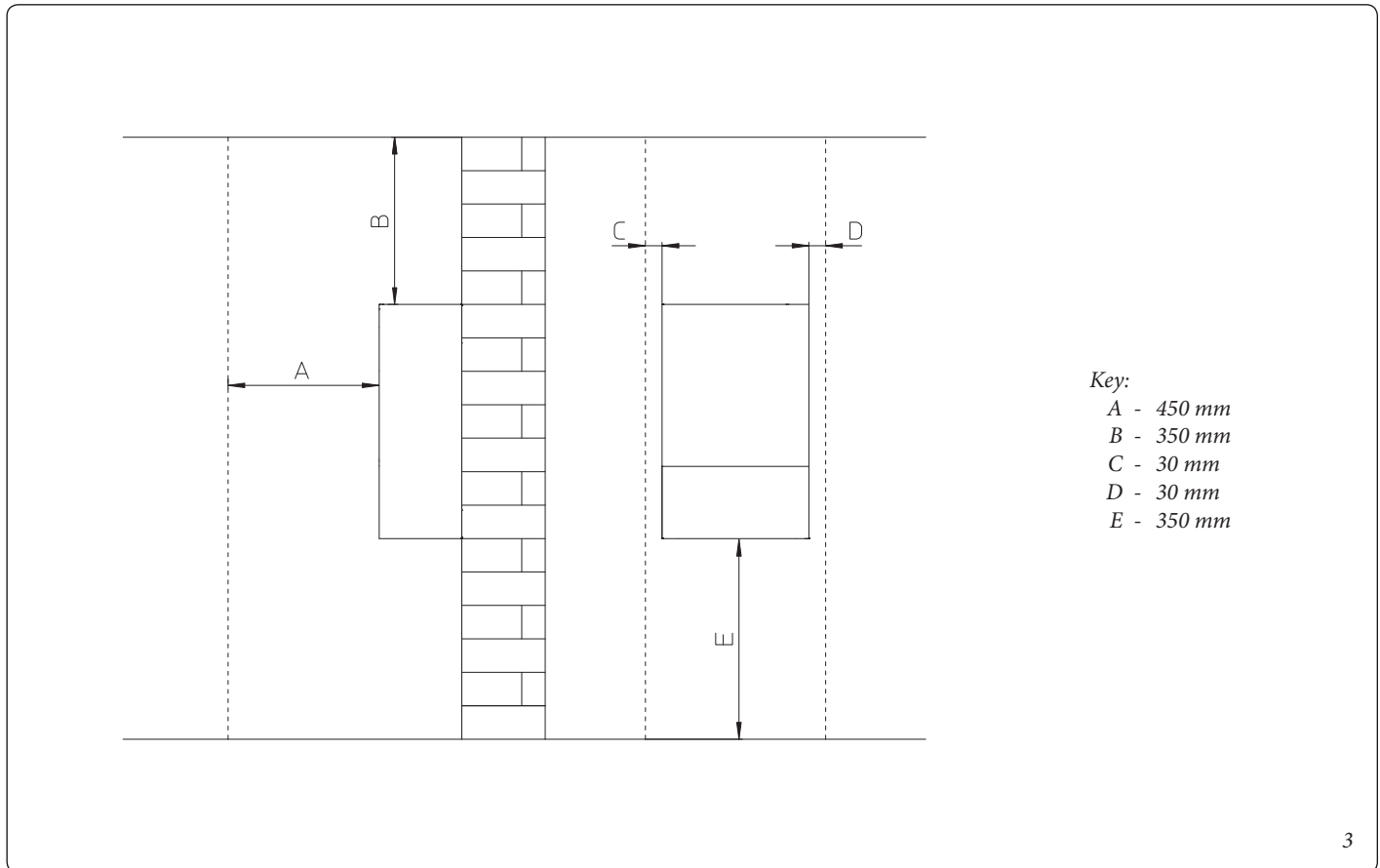

MAINTENANCE TECHNICIAN

TECHNICAL DATA

1.4 Antifreeze protection.

Minimum temperature -5°C. The boiler comes standard with an antifreeze function that activates the pump and burner when the system water temperature in the boiler falls below 4°C.



In these conditions the boiler is protected against freezing to an ambient temperature of -5°C.

Minimum temperature -15°C. If the boiler is installed in a place where the temperature falls below -5°C, and in the event there is no gas (or the boiler goes into ignition block), the appliance can freeze.

To prevent the risk of freezing follow the instructions below:

- protect the central heating circuit from freezing by inserting a good-quality antifreeze liquid into this circuit, which is specially suited for central heating systems and which is manufacturer guaranteed not to cause damage to the heat exchanger or other components of the boiler. The antifreeze liquid must not be harmful to one's health. The instructions of the manufacturer of this liquid must be followed scrupulously regarding the percentage necessary with respect to the minimum temperature at which the system must be kept.

Attention: the excessive use of glycol could jeopardise the proper functioning of the appliance.

An aqueous solution must be made with potential pollution class of water 2 (EN 1717:2002 or local standards in force).

The materials used for the central heating circuit of Immergas boilers withstand ethylene and propylene glycol based antifreeze liquids (if the mixtures are prepared perfectly).

For life and possible disposal, follow the supplier's instructions.

- Protect the domestic hot water circuit against freezing by using an accessory that is supplied on request (antifreeze kit) comprising two electric heating elements, the relevant wiring and a control thermostat (carefully read the installation instructions contained in the accessory kit pack).

In these conditions the boiler is protected against freezing to temperature of -15°C.

Boiler antifreeze protection (both -5°C and -15°C) is thus ensured only if:

- the boiler is correctly connected to gas and electricity power supply circuits;
- the boiler is powered constantly;
- the boiler is not in "off" mode.
- the boiler is not in anomaly conditions (Parag. 2.5);
- the essential components of the boiler and/or antifreeze kit are not faulty.

The warranty does not cover damage due to interruption of the electrical power supply and failure to comply with that stated on the previous page.

N.B.: if the boiler is installed in places where the temperature falls below 0°C the domestic hot water and central heating attachment pipes must be insulated.

Note: the antifreeze systems described in this chapter are only to protect the boiler. The presence of these functions and devices does not exclude the possibility of parts of the system or domestic hot water circuit outside the boiler from freezing.

1.5 Boiler connection group (Optional).

The connection unit consisting of all the necessary parts to perform the hydraulic and gas system connections of the appliance comes as optional kit, perform the connections based on the type of installation to be made and according to the layout shown in Fig 4.

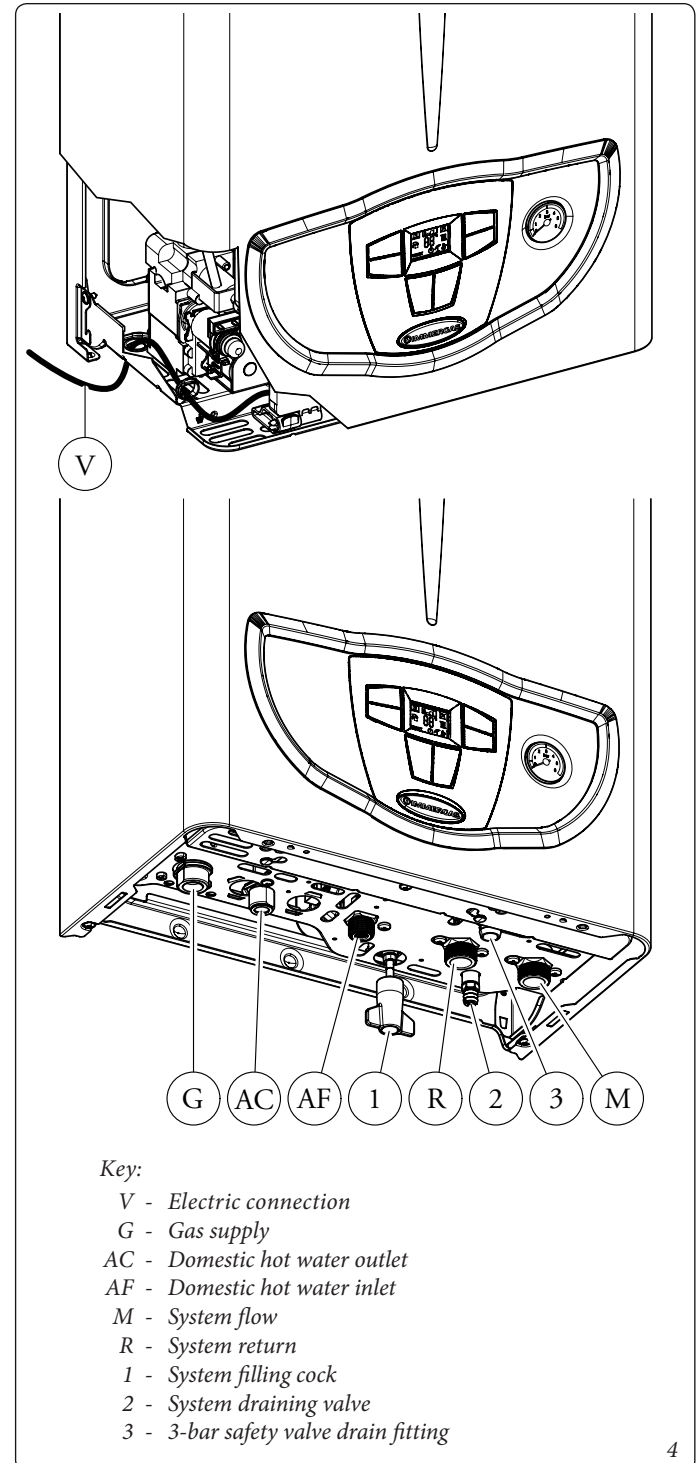

1.6 Gas connection.

Our boilers are designed to operate with methane gas (G20) or LPG. Supply pipes must be the same as or larger than the 3/4" G boiler fitting.

ATTENTION:



Before connecting the gas line, carefully clean inside all the fuel feed system pipes to remove any residue that could impair boiler efficiency. Also make sure the gas corresponds to that for which the boiler is prepared (see boiler data nameplate). If different, the boiler must be converted for operation with the other type of gas (see converting appliance for other gas types). The dynamic gas supply (methane or LPG) pressure must also be checked according to the type used in the boiler, which must be in compliance, as insufficient levels can reduce generator output and cause malfunctions. Ensure correct gas cock connection.

According to local regulations in force, make sure that a gas cock is installed upstream of each connection between the appliance and the gas system. This cock, if supplied by the appliance's manufacturer, can be directly connected to the appliance (i.e. downstream from the pipes connecting the system to the appliance), according to the manufacturer's instructions.

The Immergas connection unit, supplied as an optional kit, also includes the gas cock, whose installation instructions are provided in the kit.

In any case, make sure the gas cock is connected properly.

The gas supply pipe must be suitably dimensioned according to current regulations in order to guarantee correct gas flow rate to the burner even in conditions of maximum generator output and to guarantee appliance efficiency (technical specifications). The coupling system must conform to standards in force (EN 1775).

ATTENTION:



the appliance was designed to operate with combustible gas free of impurities; otherwise it is advisable to fit special filters upstream of the appliance to restore the purity of the fuel.

Storage tanks (in case of supply from LPG depot).

- New LPG storage tanks may contain residual inert gases (nitrogen) that degrade the mixture delivered to the appliance causing functioning anomalies.
- Due to the composition of the LPG mixture, layering of the mixture components may occur during the period of storage in the tanks. This can cause a variation in the calorific value of the mixture delivered to the appliance, with subsequent change in its performance.

1.7 Hydraulic connection.

In order not to void the heat primary exchanger warranty, before making the boiler connections, carefully clean the heating system (pipes, radiators, etc.) with special pickling or de-scaling products to remove any deposits that could compromise correct boiler operation.



A treatment of the heating and water system water is required, in compliance with the technical standards in force, in order to protect the system and the appliance from deposits (e.g. scale), slurry or other hazardous deposits.

Hydraulic connections must be made in a rational way using the couplings on the boiler template.

ATTENTION:
the manufacturer declines all liability in the event of damage caused by the installation of an automatic filling system.



In order to meet the system requirements established by EN 1717 in terms of pollution of drinking water, we recommend installing the IMMERGAS anti-backflow kit to be used upstream of the cold water inlet connection of the boiler. We also recommend using a category 2 heat transfer fluid (ex: water + glycol) in the boiler's primary circuit (C.H. circuit), as defined in standard EN 1717.

To preserve the duration of appliance efficiency features, in the presence of water whose features can lead to the deposit of lime scale, installation of the "polyphosphate dispenser" kit is recommended.



3 bar safety valve.

Safety valve discharge must always be conveyed through a draining funnel. Otherwise, the manufacturer declines any responsibility in case of flooding if the drain valve cuts in.

1.8 Electrical connection.

The appliance has an IPX5D protection degree; electrical safety of the appliance is achieved only when it is connected properly to an efficient earthing system, as specified by current safety standards.

ATTENTION:

the manufacturer declines any responsibility for damage or physical injury caused by failure to connect the boiler to an efficient earth system or failure to comply with the reference standards.



Open the control panel connections compartment (Fig. 5)

To carry out electrical connections, all you have to do is open the connections compartment as follows.

Remove the casing:

1. Loosen the screw (a) at the bottom.
2. Place the control panel (b) horizontally;
3. Remove the screw (c) securing the control panel (b) cover (d);
4. Remove the cover (d) from the control panel (b);

At this point, it is possible to access the terminal board (e).

Also ensure that the electrical installation corresponds to maximum absorbed power specifications as shown on the boiler data nameplate.

Boilers are supplied complete with an "X" type power cable without plug.

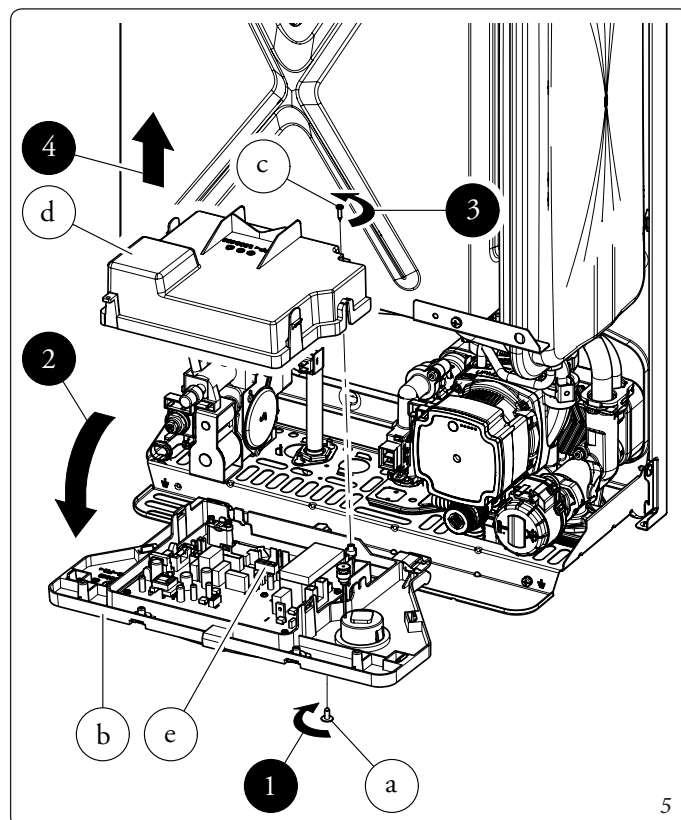

ATTENTION:

The power supply cable must be connected to a 230V~ ±10% / 50Hz mains supply respecting L-N polarity and earth connection; this network must also have a multi-pole circuit breaker with class III overvoltage category in compliance with installation regulations.



ATTENTION:

No appliance pipes must ever be used to earth the electric system or telephone lines.



ATTENTION:

To protect from possible dispersions of DC voltage, it is necessary to provide a type A differential safety device.



ATTENTION:

If the power cable is damaged, contact a qualified company (e.g. the Authorised Technical Assistance Centre) for its replacement to avoid a hazard.



The power cable must follow the prescribed route (Parag. 1.5);
If the network fuse on the P.C.B. needs replacing, this must also be done by qualified personnel: use a 5x20 250V 3.15 A fast fuse.
For the main power supply to the appliance, never use adapters, multiple sockets or extension leads.

1.9 Remote controls and room chrono-thermostats (Optional).

The boiler is prepared for the application of room chrono-thermostats or remote controls, which are available as optional kits.

Carefully read the user and assembly instructions contained in the accessory kit.

ATTENTION:

disconnect power to the appliance before any electrical connection.



• On/Off Immergas digital chrono-thermostat.

The chrono-thermostat allows:

- set two room temperature value: one for day (comfort temperature) and one for night (lower temperature);
- set a weekly programme with four daily switch on and switch off times;
- selecting the required function mode from the various possible alternatives:
- manual mode (with adjustable temperature).
- automatic mode (with set programme).
- forced automatic mode (momentarily changing the temperature of the automatic programme).

The chrono-thermostat is powered by two 1.5V LR 6 type alkaline batteries.

• **Comando Amico Remoto^{V2} Remote Control Device (CAR^{V2}) with climate timer thermostat function.**

In addition to the functions described in the previous point, the CAR^{V2} panel enables the user to control all the important information regarding operation of the appliance and the heating system with the opportunity to easily intervene on the previously set parameters, without having to go to where the appliance is installed. The panel is provided with self-diagnosis to display any boiler functioning anomalies. The climate chrono-thermostat incorporated into the remote panel enables the system flow temperature to be adjusted to the actual needs of the room being heated, in order to obtain the desired room temperature with extreme precision and therefore with evident saving in running costs.

if the system is subdivided into zones using the relevant kit, the CAR^{V2} must be used with its climate thermostat function disabled, i.e. it must be set to On/Off mode



CAR^{V2} or chrono-thermostat On/Off electric connection (Optional). *The operations described below must be performed after having removed the voltage from the appliance.* Any On/Off room chrono-thermostat must be connected to clamps 40 and 41 eliminating jumper X40 (Fig. 36). Make sure that the On/Off thermostat contact is of the “clean” type, i.e. independent of the mains voltage, otherwise the P.C.B. would be damaged. Any CAR^{V2} must be connected to clamps 40 and 41 eliminating jumper X40 on the circuit board, paying attention not to invert the polarity in the connections (Fig. 36).

If the CAR^{V2} remote control or any other On/Off chronothermostat is used, arrange two separate lines in compliance with current regulations regarding electrical systems. No boiler pipes must ever be used to earth the electric system or telephone lines. Ensure elimination of this risk before making the boiler electrical connections.

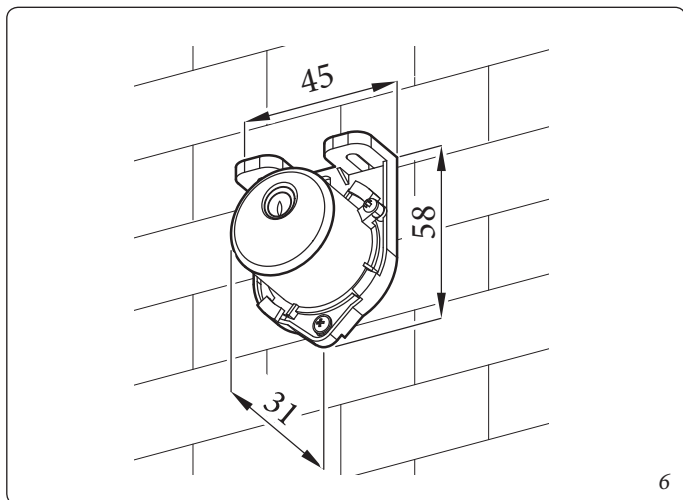

6

1.10 External temperature probe (Optional).

The boiler is designed for the application of the external temperature probe (Fig. 6), which is available as an optional kit. Refer to the relative instruction sheet for positioning of the external probe. The probe can be connected directly to the boiler electrical system and allows the max. system flow temperature to be automatically decreased when the external temperature increases, in order to adjust the heat supplied to the system according to the change in external temperature. The external probe always operates when connected, regardless of the presence or type of room chrono-thermostat used and can work in combination with Immergas chrono-thermostats. The correlation between system flow temperature and external temperature is determined by the position of the central heating selector switch on the boiler control panel (or on the CAR^{V2} control panel if connected to the boiler) according to the curves shown in the diagram (Fig. 7). The electric connection of the external probe must be made on clamps 38 and 39 on the terminal board in the boiler control panel (Fig. 36).

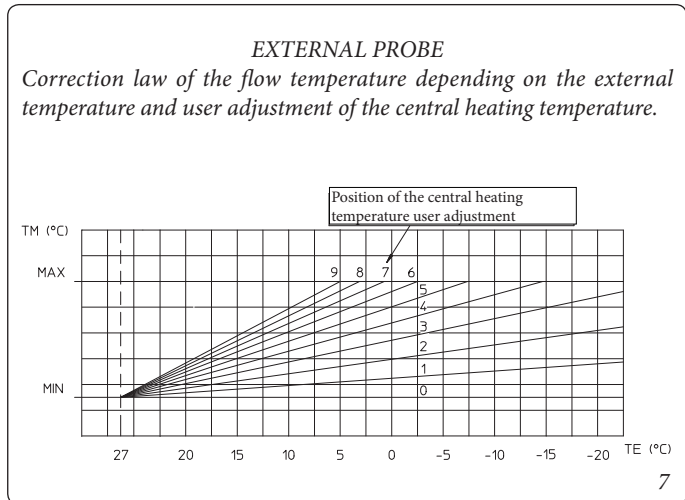

7

1.11 Immergas flue systems.

Immergas supplies various solutions separately from the boilers regarding the installation of air intake terminals and flue exhaust, which are fundamental for boiler operation.

ATTENTION:

the boiler must only be installed together with an original Immergas air intake and flue gas exhaust system.



This flue can be identified by an identification mark and special distinctive marking bearing the note "not for condensing boilers".

The flue exhaust pipes must not be in contact with or be near to flammable materials. Moreover, they must not pass through buildings or walls made of flammable material.

See following paragraphs for the detailed description of the kits available

• Positioning of double lip seals.

For correct positioning of lip seals on elbows and extensions, follow the direction of assembly given in figure (Fig. 8).

• Resistance factors and equivalent lengths.

Each flue component has a *Resistance Factor* based on experimental tests and specified in the table below. The Resistance Factor for individual components is independent from the type of boiler on which it is installed and has a dimensionless size. It is however, conditioned by the temperature of the fluids that pass through the pipe and therefore, varies according to applications for air intake or flue exhaust. Each single component has a resistance corresponding to a certain length in metres of pipe of the same diameter; the so-called *equivalent length*, can be obtained from the ratio between the relative Resistance Factors.

All boilers have an experimentally obtainable maximum Resistance Factor equal to 100.

The maximum Resistance Factor allowed corresponds to the resistance encountered with the maximum allowed pipe length for each type of Terminal Kit. This information allows calculations to be made to verify the possibility of setting up various flue configurations.

- Coupling of extension pipes. To install any push-fit extensions with other flue extraction elements, it is necessary to do the following: install the concentric pipe or elbow with the male side (smooth) on the female section (with lip seal) to the end stop on the previously installed element. This will ensure the sealing and joining of the elements correctly.

ATTENTION:

if the exhaust terminal and/or extension concentric pipe needs shortening, consider that the internal duct must always protrude by 5 mm with respect to the external duct.



Diaphragm installation.

ATTENTION:

based on the boiler model (checking which type of fan is installed), use appropriate diaphragms.



For correct functioning of the boiler it is necessary to install a diaphragm on the outlet of the sealed chamber and before the intake and exhaust pipe. The appropriate diaphragm is chosen based on type of pipe and its maximum extension: this calculation can be made using the tables below:

N.B.: the diaphragms are supplied together with the boiler.

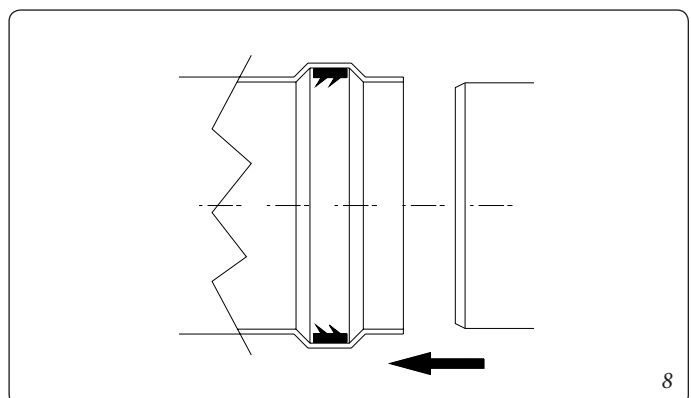

FAN POWER: 30W (Fig. 9).

Diaphragm (ref. 1 fig. 9)	Pipe extension in metres Ø 60/100 horizontal
Ø 85	From 0 to 0.5
Ø 83	From 0.5 to 1.5
WITHOUT	Exceeding 1.5

Diaphragm (ref. 1 fig. 9)	Pipe extension in metres Ø 60/100 vertical
Ø 85	From 0 to 2.2
Ø 83	From 2.2 to 3.7
WITHOUT	Exceeding 3.7

Diaphragm (ref. 1 fig. 9)	Pipe extension in metres Ø 80/125 horizontal
Ø 85	From 0 to 0.5
Ø 83	From 0.5 to 4.6
WITHOUT	Exceeding 4.6

Diaphragm (ref. 1 fig. 9)	Pipe extension in metres Ø 80/125 vertical
Ø 85	From 0 to 5.4
Ø 83	From 5.4 to 9.5
WITHOUT	Exceeding 9.5

Diaphragm (ref. 2 fig. 9)	Pipe extension in metres Ø 80 divided	
	intake	exhaust
Ø 20.5	From 0.5 to 15	1
Ø 15	From 15 to 35	1

Diaphragm (ref. 2 fig. 9)	Pipe extension in metres Ø 80 divided	
	intake	exhaust
Ø 20.5	1	From 0.5 to 8
Ø 15	1	From 8 to 16
WITHOUT	1	Exceeding 16

FAN POWER: 33W / 39W (Fig. 10).

Diaphragm (fig. 10)	Pipe extension in metres Ø 60/100 horizontal
Ø 40	From 0 to 0.5
Ø 41.5	From 0.5 to 1.5
WITHOUT	Over 1.5

Diaphragm (fig. 10)	Pipe extension in metres Ø 60/100 vertical
Ø 40	From 0 to 2.2
Ø 41.5	From 2.2 to 3.2
WITHOUT	Over 3.2

Diaphragm (fig. 10)	*Extension in metres horizontal pipe Ø 80 with two bends
Ø 40	From 0 to 17
Ø 41.5	From 17 to 24
WITHOUT	Over 24

Diaphragm (fig. 10)	*Extension in metres vertical pipe Ø 80 without bends
Ø 40	From 0 to 22
Ø 41.5	From 22 to 29
WITHOUT	Over 29







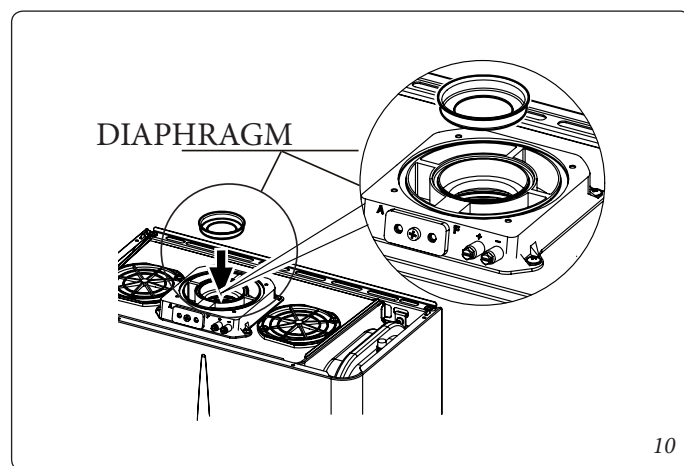
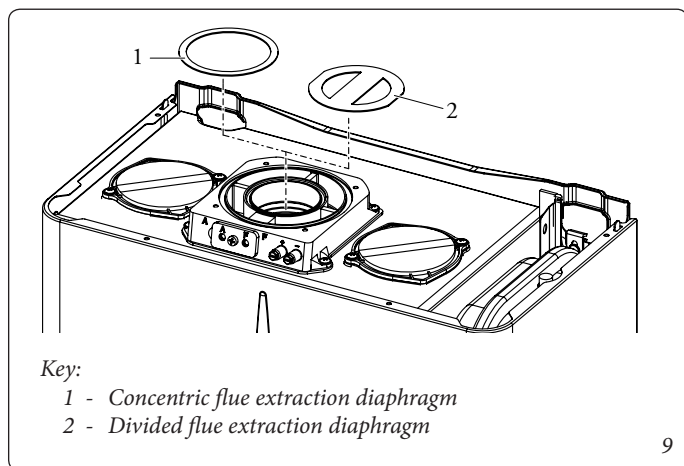



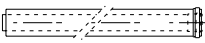

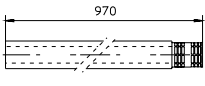

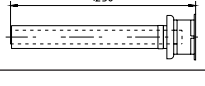
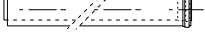

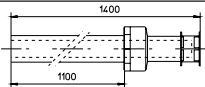
Diaphragm (fig. 10)	Pipe extension in metres Ø 80/125 horizontal
Ø 40	From 0 to 0.5
Ø 41.5	From 0.5 to 3.3
WITHOUT	Over 3.3

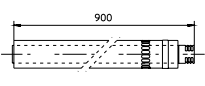
Diaphragm (fig. 10)	Pipe extension in metres Ø 80/125 vertical
Ø 40	From 0 to 5.4
Ø 41.5	From 5.4 to 8.1
WITHOUT	Over 8.1

* The values for maximum length are considered with 1 metre of exhaust pipe and the remaining on intake.

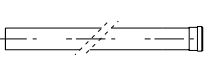
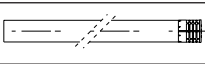

1.12 TABLES OF RESISTANCE FACTORS AND EQUIVALENT LENGTHS.

TYPE OF DUCT	Resistance Factor (R)	Equivalent length in m of concentric pipe Ø 60/100	Equivalent length in m of concentric pipe Ø 80/125	Equivalent length in m of pipe Ø 80
Concentric pipe Ø 60/100 m 1 	Intake and Exhaust 16.5	m 1	m 2.8	Intake m 7.1
				Exhaust m 5.5
Concentric bend 90° Ø 60/100 	Intake and Exhaust 21	m 1.3	m 3.5	Intake m 9.1
				Exhaust m 7.0
Concentric bend 45° Ø 60/100 	Intake and Exhaust 16.5	m 1	m 2.8	Intake m 7.1
				Exhaust m 5.5
Terminal complete with intake-exhaust horizontal concentric Ø 60/100 	Intake and Exhaust 46	m 2.8	m 7.6	Intake m 20
				Exhaust m 15
Intake-exhaust terminal horizontal concentric Ø 60/100 	Intake and Exhaust 32	m 1.9	m 5.3	Intake m 14
				Exhaust m 10.6
Intake-exhaust terminal vertical concentric Ø 60/100 	Intake and Exhaust 41.7	m 2.5	m 7	Intake m 18
				Exhaust 14
Concentric pipe 80/125 Ø m 1 	Intake and Exhaust 6	m 0.4	1.0 m	Intake m 2.6
				Exhaust m 2.0
Concentric bend 90° 80/125 Ø 	Intake and Exhaust 7.5	m 0.5	m 1.3	Intake m 3.3
				Exhaust m 2.5
Concentric bend 45° Ø 80/125 	Intake and Exhaust 6	m 0.4	1.0 m	Intake m 2.6
				Exhaust m 2.0
Terminal complete with intake-exhaust vertical concentric Ø 80/125 	Intake and Exhaust 33	m 2.0	m 5.5	Intake m 14.3
				Exhaust m 11.0
Intake-exhaust terminal vertical concentric Ø 80/125 	Intake and Exhaust 26.5	m 1.6	m 4.4	Intake m 11.5
				Exhaust m 8.8
Terminal complete with intake-exhaust horizontal concentric Ø 80/125 	Intake and Exhaust 39	m 2.3	m 6.5	Intake m 16.9
				Exhaust m 13
Intake-exhaust terminal horizontal concentric Ø 80/125 	Intake and Exhaust 34	m 2.0	m 5.6	Intake m 14.8
				Exhaust m 11.3
Concentric adapter from Ø 60/100 to Ø 80/125 with condensate trap 	Intake and Exhaust 13	m 0.8	m 2.2	Intake m 5.6
				Exhaust m 4.3
Concentric adapter from Ø 60/100 to Ø 80/125 	Intake and Exhaust 2	m 0.1	m 0.3	Intake m 0.8
				Exhaust m 0.6
Pipe Ø 80 m 1 (with and without insulation) 	Intake 2.3	m 0.1	m 0.4	Intake m 1.0
				Exhaust 3
Complete intake terminal Ø 80 m 1 (with or without insulation) 	Intake 5	m 0.3	m 0.8	Intake m 2.2
Complete intake terminal Ø 80 m 1 (with or without insulation) 	Intake 3	m 0.2	m 0.5	Intake m 1.3
				Exhaust 2.5
Bend 90° Ø 80 	Intake 5	m 0.3	m 0.8	Intake m 2.2
				Exhaust 6.5
Bend 45° Ø 80 	Intake 3	m 0.2	m 0.5	Intake m 1.3
				Exhaust 4
Divided parallel Ø 80 from Ø 60/100 to Ø 80/80 	Intake and Exhaust 8.8	m 0.5	m 1.5	Intake m 3.8
				Exhaust m 2.9

INSTALLER

USER

MAINTENANCE TECHNICIAN

TECHNICAL DATA

1.13 Outdoor installation in partially protected area.

A partially protected location is a place where the appliance is not exposed to the direct effects of the weather (rain, snow, hail, etc.).



If the appliance is installed in a place where the ambient temperature drops below 0°C, use the optional antifreeze kit, checking the ambient operating temperature range shown in the technical data table in this instruction booklet.



• Configuration type B, open chamber and fan assisted.

The relevant terminal must be used for this configuration (present in the intake kit for the installation in question), which must be placed on the central hole of the boiler (Fig. 13). Air intake takes place directly from the environment in which the boiler is installed and flue exhaust in individual flue or to the outside.

In this configuration the boiler is classified as type B₂₂.

With this configuration:

- air intake takes place directly from the environment in which the boiler is installed and only functions in permanently ventilated rooms;
- the flue exhaust must be connected to its own individual flue

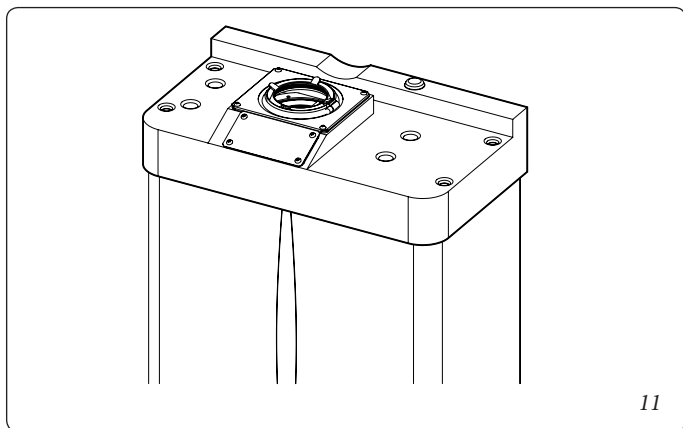

11

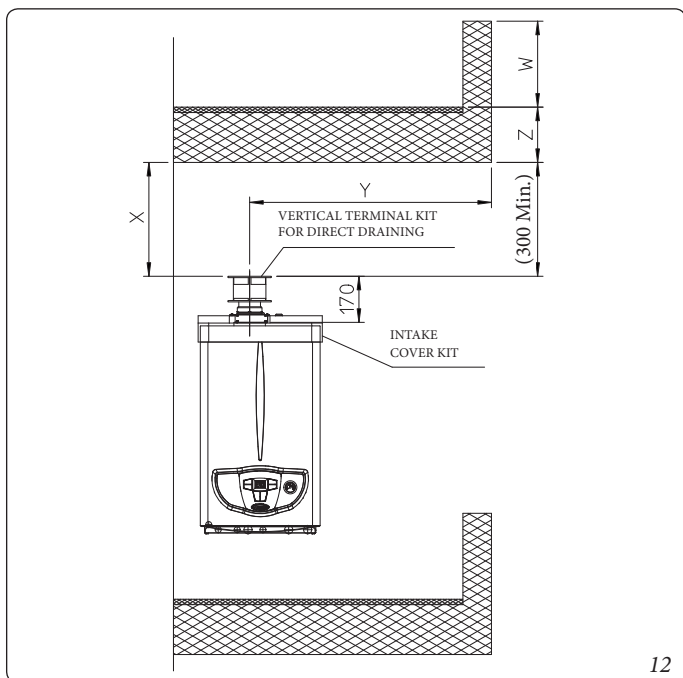

12

or channelled directly into the external atmosphere.

The technical regulations in force must be respected.

• Fitting the cover kit.

To assemble and configure the cover kit correctly, please refer to the relative instructions sheet.

• Max. length of exhaust duct.

The flue pipe (vertical or horizontal) can be extended to a max. length of 12 m straight route, using insulated pipes (Fig. 29). To prevent problems of fume condensate in the exhaust pipe Ø 80, due to fume cooling through the wall, the length of the pipe (not insulated) must be limited to just 5 m.

Example of installation with direct vertical terminal in partially protected location.

When the vertical terminal for direct discharge of combustion fumes is used, a minimum gap of 300 mm must be left between the terminal and the balcony above. The height X+Y+Z+W evaluated with respect to the balcony above, must be equal to or more than 2000 mm (Fig. 12). The term W must only be considered if the balcony above has closed balustrade (W=0 if the balustrade is open).

• Configuration without cover kit (boiler type C).

By leaving the side plugs fitted, it is possible to install the appliance externally, in partially covered places, without the cover kit. Installation takes place using the Ø60/100 and Ø80/125 concentric horizontal intake/ exhaust kits. Refer to the paragraph relative to indoor installation. In this configuration the top cover kit guarantees additional protection for the boiler. It is recommended but not compulsory.

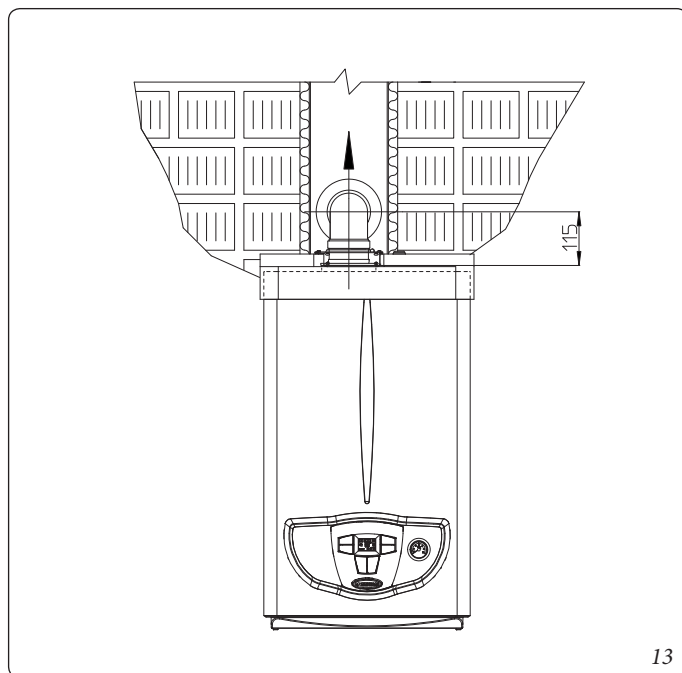

13

1.14 Concentric horizontal kit installation.

Type C configuration, sealed chamber and fan assisted.

Installation of this terminal is governed by standards contained in local building regulations, as amended.

N.B.: in addition to the traditional “Ø60/100 horizontal kit” there is also a specific “Ø60/100 Star” version, with the same measurements and equivalent head loss.

This terminal is connected directly to the outside of the building for air intake and flue exhaust. The horizontal kit Ø 60/100 can be installed with the rear, right side, left side or front outlet.

- External grid. **N.B.:** for safety purposes, do not obstruct the boiler intake-exhaust terminal, even temporarily.

Horizontal intake - exhaust kit Ø60/100. Kit assembly (Fig. 14): install the bend with flange (2) onto the central hole of the boiler inserting the gasket (1) and tighten using the screws included in the kit. Couple the terminal pipe (3) with the male end (smooth) into the female end of the bend (with lip seals) up to the stop; making sure that the internal wall sealing plate and external wall sealing plate have been fitted, this will ensure sealing and joining of the elements making up the kit.

- Application with rear outlet (Fig. 15). The 970 mm pipe length enables routing through a maximum thickness of 770 mm. Normally the terminal must be shortened. Calculate the measurement by the sum of these values: Wall thickness + indoor extension + outdoor extension. The minimum indispensable projection values are given in the figure.
- Application with side outlet (Fig. 16). Using the horizontal intake-exhaust kit, without the special extensions, enables routing through a wall thickness of 725 mm with the left side outlet and 645 with the right side outlet.
- Extensions for horizontal kit. The Ø 60/100 horizontal intake-exhaust kit can be extended up to a max. horizontal length of 3000 mm, including the terminal with grille and excluding the concentric bend leaving the boiler. This configuration corresponds to a resistance factor of 100. In these cases the special extensions must be requested.

Connection with 1 extension (Fig. 17). Max. distance between vertical boiler axis and external wall is 1855mm.

Connection with 2 extensions (Fig. 18). Max. distance between vertical boiler axis and external wall is 2805mm.

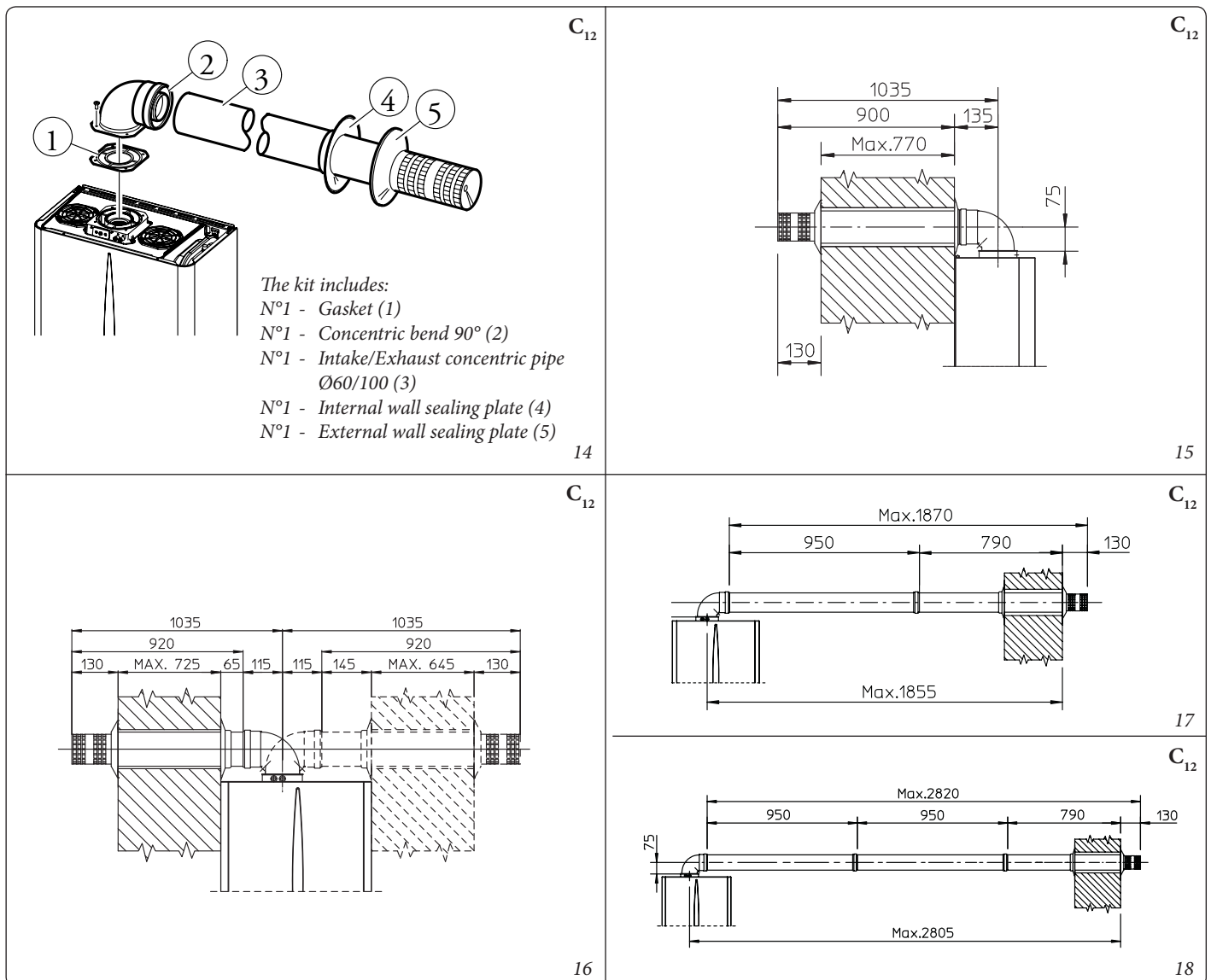

Horizontal intake - exhaust kit Ø80/125. Kit assembly (Fig. 19): install the bend with flange (2) onto the central hole of the boiler inserting the gasket (1) and tighten using the screws included in the kit. Fit the male end (smooth) of the adapter (3) up to the end stop on the female side of the bend (2) (with lip seal). Fit the Ø 80/125 (4) concentric terminal pipe with the male end (smooth) to the female end of the adapter (3) (with lip gasket) up to the stop; making sure that the internal and external wall sealing plates have been fitted; this will ensure sealing and joining of the elements making up the kit.

Normally the horizontal intake/exhaust kit Ø 80/125 is used if particularly long extensions are required.

- Extensions for horizontal kit. The Ø 80/125 horizontal intake-exhaust kit can be extended up to a *max. horizontal distance of 7,300 mm* including the terminal with grid and excluding the concentric bend leaving the boiler and the adapter Ø 60/100 in Ø 80/125 (Fig. 20). This configuration corresponds to a resistance factor of 100. In these cases the special extensions must be requested.

When installing the pipes, a section clamp with pin must be installed every 3 metres.



1.15 Concentric vertical kit installation.

Type C configuration, sealed chamber and fan assisted.

Concentric vertical intake and exhaust kit. This vertical terminal is connected directly to the outside of the building for air intake and flue exhaust.

N.B.: the vertical kit with aluminium tile enables installation on terraces and roofs with a maximum slope of 45% (approx 25°) and the height between the terminal cap and half-shell (374 mm) must always be observed.

Vertical kit with aluminium tile Ø 80/125. Kit assembly (Fig. 21): install the concentric flange (2) on the central hole of the boiler inserting the gasket (1) and tighten using the screws in the kit. Fit the male end (smooth) of the adapter (3) into the female end of the concentric flange (2). Imitation aluminium tile installation. Replace the tile with the aluminium sheet (5), shaping it to ensure that rainwater runs off. Position the fixed half-shell (7) and insert the intake-exhaust pipe (6). Fit the Ø 80/125 concentric terminal pipe with the male end (6) (smooth) to the female end of the adapter (3) (with lip gasket) up to the stop; making sure that the wall sealing plate (4) has been fitted, this will ensure sealing and joining of the elements making up the kit.

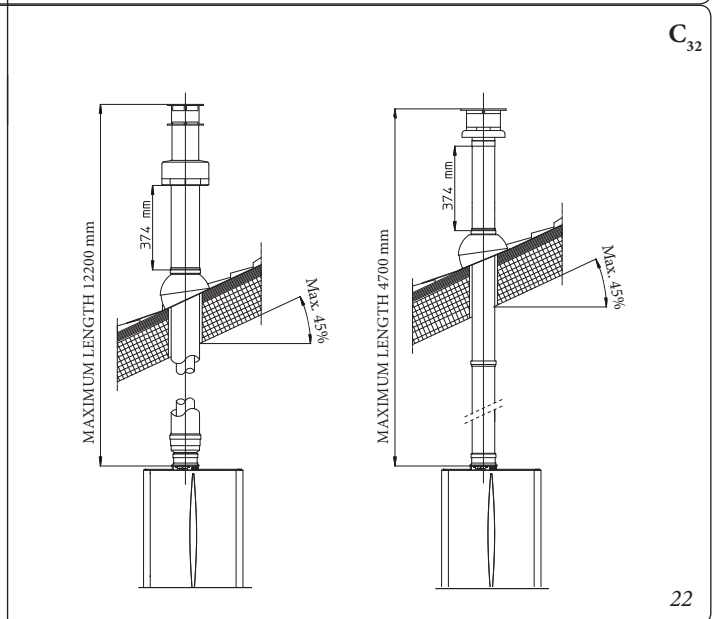
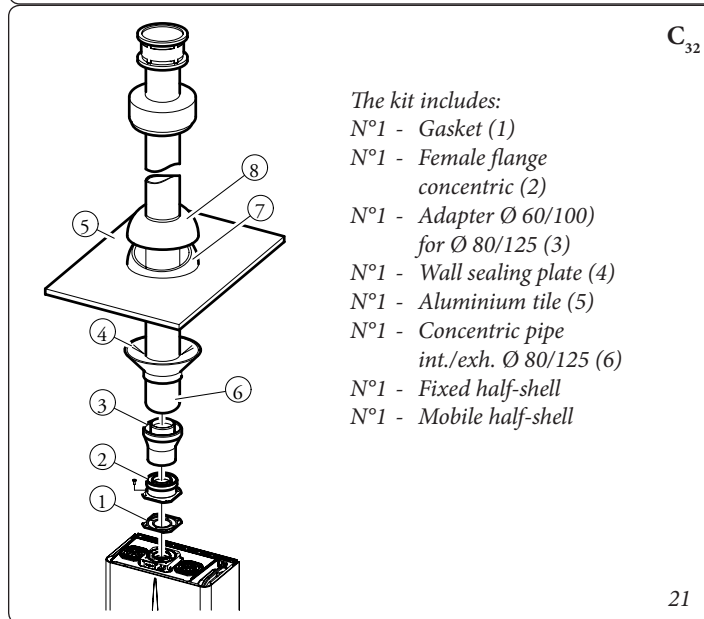
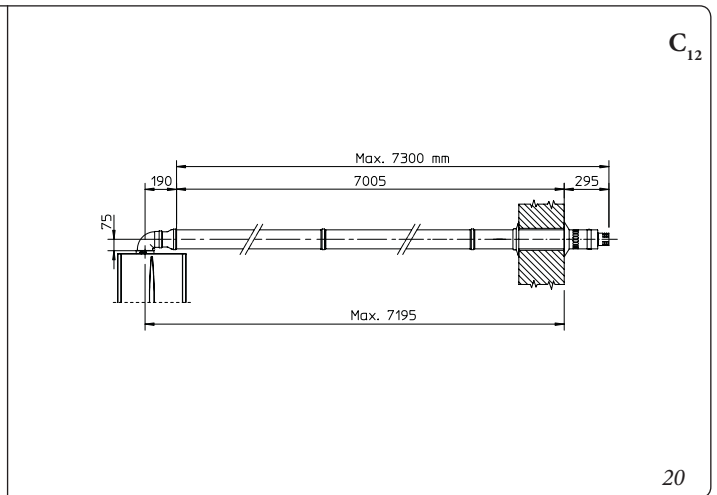
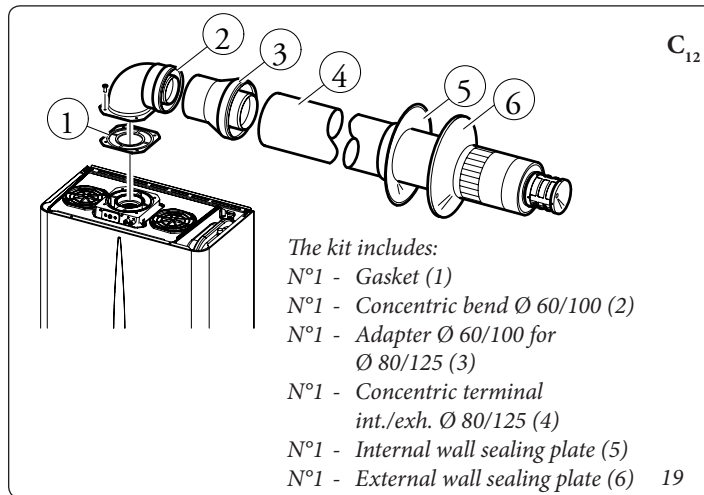

The vertical kit with this configuration can be extended to a *max. straight vertical length of 12200 mm* including the terminal (Fig. 22). This configuration corresponds to a resistance factor of 100. In this case the special extensions must be requested.

The terminal Ø 60/100 can also be used for vertical exhaust, in conjunction with concentric flange code 3.011141 (sold separately).

The vertical kit with this configuration can be extended to a *max. straight vertical length of 4700 mm* including the terminal (Fig. 22).

1.16 Separator kit installation.

Type C configuration, sealed chamber and fan assisted.

This kit allows air to come in from outside the building and the exhaust to exit from the chimney or flue through divided flue exhaust and air intake pipes. Combustion products are expelled from pipe (S). The required amount of air is taken in through pipe (A) for combustion. The intake pipe (A) can be installed either on the right or left hand side of the central exhaust pipe (S). Both ducts can be routed in any direction.

Please note the type of installation C₄ must be done with a natural draught flue. Moreover, with C₅ configuration, intake and exhaust pipes cannot be installed on opposing walls.

- **Separator kit Ø 80/80.** Kit assembly (Fig. 23): install the flange (4) on the central hole of the boiler, interposing the gasket (1) and tighten with the flat-tipped hex screws included in the kit. Remove the flat flange present in the lateral hole with respect to the central one (according to needs) and replace it with the flange (3), positioning the gasket (2) already present in the boiler and tighten using the supplied self-threading screws. Fit the male end (smooth) to the bends (5) in the female end of the flanges (3 and 4). Fit the intake terminal (6) with the male section (smooth) in the female section of the bend (5) up to the stop, ensuring that the internal and external wall sealing plates are fitted. Fit the exhaust pipe (9) with the male end (smooth) to the female end of the bend (5) up to the stop; making sure that the internal wall sealing plate has been fitted, this will ensure sealing and joining of the elements making up the kit.

- **Installation clearances.**

Figure 24 gives the min. installation space dimensions of the Ø 80/80 separator terminal kit in limited conditions.

- Figure 25 shows the configuration with vertical exhaust and horizontal intake.

- **Extensions for separator kit Ø 80/80.**

The max. vertical linear length (without bends) usable for Ø 80 intake and exhaust pipes is 41 metres of which 40 intake and 1 exhaust. This total length corresponds to a resistance factor of 100. The total usable length obtained by the sum of the Ø 80 intake and exhaust pipe lengths can reach, as a maximum, the values provided in the following table. If *mixed accessories or components are used*, the maximum extension can be calculated by using a resistance factor for each component or its *equivalent length*. The sum of these resistance factors must not exceed 100.

- **Temperature loss in flue ducts.**

To prevent problems of flue gas condensate in the exhaust pipe Ø 80, due to fume cooling through the wall, *the length of the pipe must be limited to just 5 m*. Fig. 26). If longer distances must be covered, use Ø 80 pipes with insulation (see insulated separator kit Ø 80/80 chapter).

When installing the Ø 80 ducts, a dividing strip with gusset must be installed every 3 metres.



The kit includes:

N°1 - Exhaust gasket (1)	N°2 - 90° bend Ø 80 (5)
N°1 - Female intake flange (3)	N°1 - Intake terminal Ø 80 (6)
N°1 - Flange gasket (2)	N°2 - Internal wall sealing plates (7)
N°1 - Female exhaust flange (4)	N°1 - External wall sealing plate (8)
	N°1 - Exhaust pipe Ø 80 (9)

C₈₂ * Configuration C₄ envisages connection to flues working with natural draught. **C₄₂**

23
24

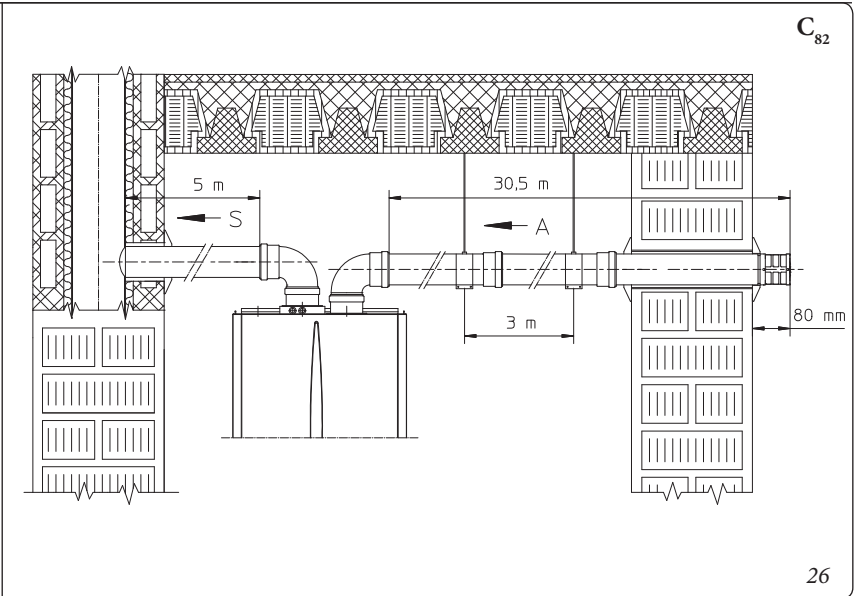
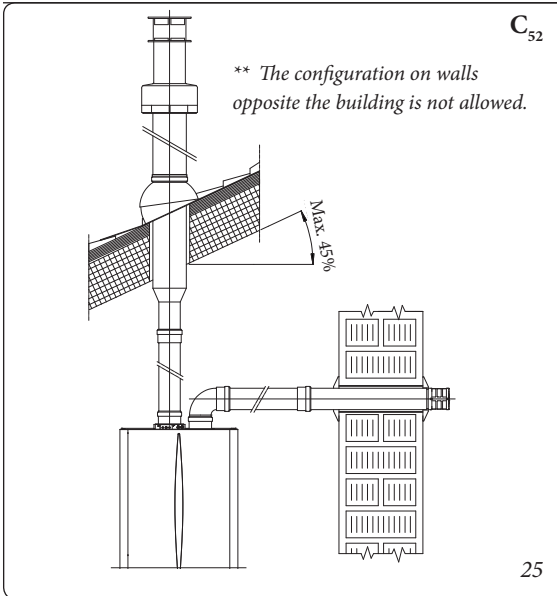

Maximum usable lengths (including intake terminal with grill and two 90° bends)			
NON-INSULATED PIPE		INSULATED PIPE	
Drain (metres)	Intake (metres)	Drain (metres)	Intake (metres)
1	36.0*	6	29.5*
2	34.5*	7	28.0*
3	33.0*	8	26.5*
4	32.0*	9	25.5*
5	30.5*	10	24.0*
* The air intake pipe can be increased to 2.5 metres if the exhaust bend is eliminated, 2 metres if the air intake bend is eliminated, 4.5 metres eliminating both bends.		11	22.5*
		12	21.5*

ATTENTION:  the boiler is designed to evacuate the combustion products up to a maximum extension of 27 linear metres from the exhaust, with 1 m plus 90° bend at the intake. If the installation requests a development of the flue to the discharge that exceeds the recommended 12 m, due consideration must be given to the formation of condensate that could take place inside the pipe and Immergas insulated “Blue Series” flue kits must be used. It's not allowed that condensation flow towards the appliance from exhaust ducts.

- **Insulated separator kit Ø 80/80.** Kit assembly (Fig. 27): install the flange (4) on the central hole of the boiler, interposing the gasket (1) and tighten with the flat-tipped hex screws included in the kit. Remove the flat flange present in the lateral hole with respect to the central one (according to needs) and replace it with the flange (3), positioning the gasket (2) already present in the boiler and tighten using the supplied self-threading screws. Insert and slide cap (6) onto bend (5) from the male side (smooth), and join bends (5) with the male side (smooth) in the female side of flange (3). Fit bend (11) with the male side (smooth) into the female side of flange (4). Fit the male end (smooth) of the intake terminal (7) up to the stop on the female end of the bend (5), making sure you have already inserted the wall sealing plates (8 and 9) that ensure correct installation between pipe and wall, then fix the closing cap (6) on the terminal (7). Join the exhaust pipe (10) with the male side (smooth) in the female side of the bend (11) to the end stop, ensuring that the wall sealing plate (8) is already inserted for correct installation between the pipe and flue.
- **Insulation of separator terminal kit.** Whenever there are flue gas condensate problems in the exhaust pipes or on the external surface of the intake pipes, on request Immergas supplies insulated intake-exhaust pipes. Insulation may be necessary on the exhaust pipe, due to excessive loss of temperature of the flue gas on their route. Insulation may be necessary on the intake pipe as the air entering (if very cold) may cause the outside of the pipe to fall below the dew point of the environmental air.

The figures (Fig. 28 and 29) illustrate different applications of insulated pipes.

Insulated pipes are formed of a Ø 80 internal concentric pipe and a Ø 125 external pipe with static air space. It is not technically possible to start with both Ø 80 elbows insulated, as clearances will not allow it. However starting with an insulated elbow is possible by choosing either the intake or exhaust pipe. When starting with the insulated intake bend it must be engaged on its flange until it is taken up to stop on the flue gas exhaust flange, a situation that takes the two intake flue gas exhaust outlets to the same height.

- **Temperature loss in insulated flue ducting.** To prevent problems of flue gas condensate in the exhaust pipe Ø 80, due to flue gas cooling through the wall, *the length of the pipe must be limited to 12 m.* The figure (Fig. 29) illustrates a typical insulation application in which the intake pipe is short and the exhaust pipe is very long (over 5 m). The entire intake pipe is insulated to prevent moist air in the place where the boiler is installed, in contact with the pipe cooled by air entering from the outside. The entire exhaust pipe, except the elbow leaving the splitter is insulated to reduce heat loss from the pipe, thus preventing the formation of fume condensate.

When installing the insulated pipes, a section clamp with pin must be installed every 2 metres.

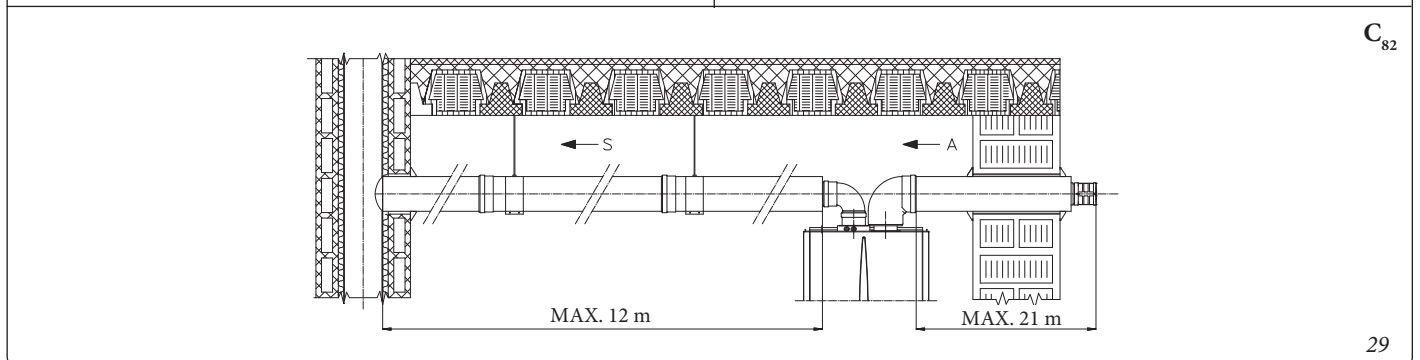
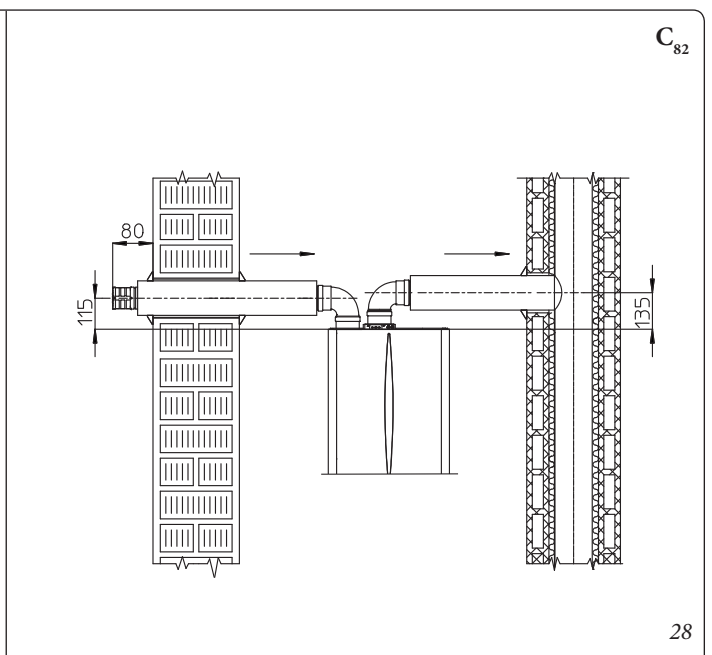
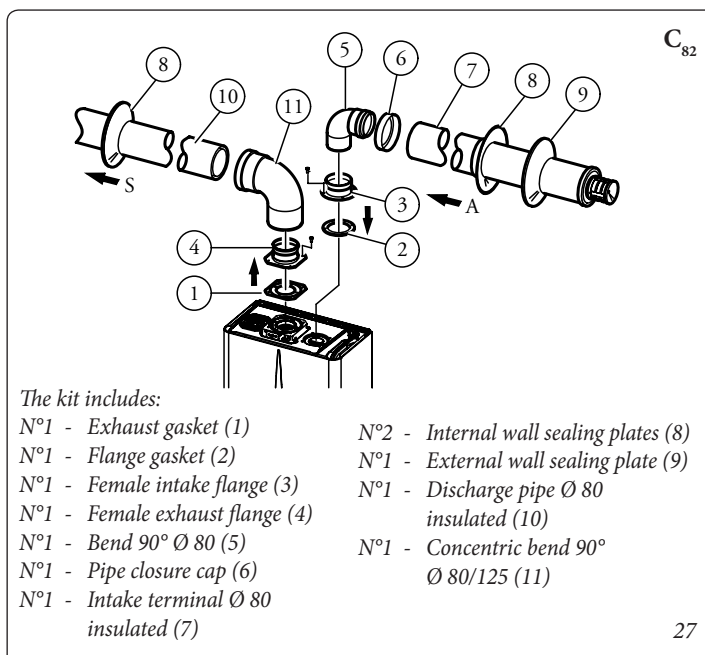

1.17 Flue exhaust to flue/chimney.

Flue exhaust does not necessarily have to be connected to a branched type traditional flue. The flue exhaust can be connected to a special LAS type multiple flue. Multiple and combined flues must be specially designed according to the calculation method and requirements of the standards, by professionally qualified technical staff. Chimney or flue sections for connection of the exhaust pipe must comply with requisites of technical standards in force.

Gas type		G20	G31
Flue temperature at maximum output	°C	135	136
Flue gas mass at maximum power	kg/h	57	58
Flue temperature at minimum output	°C	101	106
Flue gas mass at minimum power	kg/h	59	58
CO ₂ at Q. max.	%	6,4	7,2
CO ₂ a Q. minimum	%	2,4	2,8
Maximum head available at the flue at maximum power (maximum resistance value of the commercial flue system)	Pa	100	
Maximum head available at the flue at minimum power	Pa	100	
Maximum temperature achievable in the exhaust ducts	°C	180	

- Ducts must withstand condensation (only for condensing models);
- Air intake ducts must withstand working air temperatures of up to 60°C;
- The maximum permissible percentage of flue gas recirculation in windy conditions is 10%.
- Suction and exhaust pipes cannot be installed on opposing walls;
- With flues in configuration C₆ discharge into pressurised flues is not permitted.



1.18 Ducting of flues or technical slots.

Ducting is an operation through which by the introduction of one or more relevant pipes, a system is realised for the evacuation of the combustion products of a gas appliance made up from the coupling of an existing or new ducting pipe with a chimney, flue or technical slot (also in new buildings). Ducting requires the use of ducts declared to be suitable for the purpose by the manufacturer. Follow the installation and user instructions provided by the manufacturer and the requirements set forth by standards.

1.19 Configuration for C6 flue installation.

Appliance designed to be connected to a commercial exhaust/intake system.

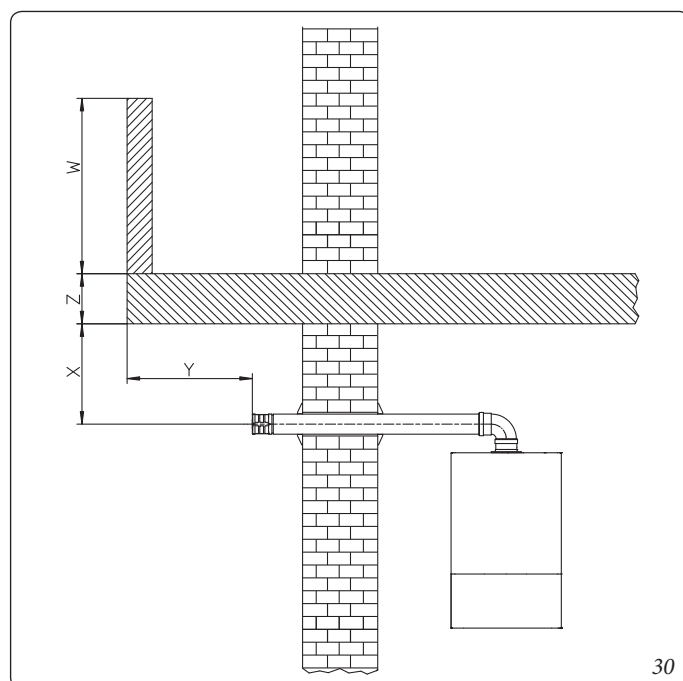

1.20 Flues, chimneys and chimney caps.

The flues, chimneys and chimney caps for the evacuation of combustion products must be in compliance with applicable standards. Chimneys and roof-installed exhaust terminals must comply with the outlet height and with the distance from technical volumes set forth by the technical standards in force.

Positioning the wall exhaust terminals. The exhaust terminals must:

- be installed on external perimeter walls of the building (fig. 30);
- be positioned according to the minimum distances specified in current technical standards.

Combustion products exhaust of natural or fan assisted appliances in open-top closed environments. In spaces closed on all sides with open tops (ventilation pits, courtyards etc.), direct flue gas exhaust is allowed for natural or forced draught gas appliances with a heating power range from 4 to 35 kW, provided the conditions as per the current technical standards are respected.

1.21 System filling.

Once the boiler is connected, proceed with system filling via the filling valve (Fig. 34).

Filling is performed at low speed to ensure release of air bubbles in the water via the boiler and heating system vents.

The boiler has a built-in automatic venting valve on the circulator. Check if the cap is loose.

Open the radiator vent valves. Close radiator vent valves when only water escapes from them.

Close the filling valve when the boiler manometer indicates approx. 1.2 bar.

N.B.: during these operations turn on the circulation pump at intervals, by means of the stand-by/summer winter button (2) positioned on the control panel. *Vent the circulation pump by loosening the front cap and keeping the motor running.*

Tighten the cap after the operation.

1.22 Gas system start-up.

To start up the system, refer to the standard in force.

In particular, for new gas systems:

- open windows and doors;
- avoid presence of sparks or naked flames;
- bleed all air from pipelines;
- check that the internal system is properly sealed according to specifications.

1.23 Boiler start up (ignition).

For issue of the Declaration of Conformity provided for by Italian Law, the following must be performed for boiler start-up:

- check that the internal system is properly sealed according to specifications;
- ensure that the type of gas used corresponds to boiler settings;
- switch the boiler on and ensure correct ignition;
- make sure that the gas flow rate and relevant pressure values comply with those given in the manual (Par. 4.1 / 4.4);
- ensure that the safety device is engaged in the event of gas supply failure and check activation time;
- check activation of the main switch located upstream from the boiler;
- check that the concentric intake-exhaust terminal (if fitted) is not blocked.

The boiler must not be started up even if only one of the checks should be negative.

N.B.: *the preliminary boiler check must be carried out by a qualified technician. The standard boiler warranty is valid from the date of inspection.*

The test certificate and warranty is issued to the user.

1.24 Circulation pump.

The boilers are supplied with a built-in circulation pump with three-position electric speed control. The boiler does not operate correctly with the circulation pump on first speed. To ensure optimal boiler operation, in the case of new systems (single pipe and module) it is recommended to use the pump at maximum speed. The circulation pump is already fitted with a condenser.

Pump release. If, after a prolonged period of inactivity, the circulation pump is blocked, unscrew the front cap and turn the motor shaft using a screwdriver. Take great care during this operation to avoid damage to the motor.

By-pass adjustment (Part. 25 Fig. 32). If necessary, the by-pass can be adjusted according to system requirements from a minimum (by-pass excluded) to a maximum (by-pass inserted) represented by the graph (Fig. 31). Make the adjustment using a flat head screwdriver, turn clockwise and insert the by-pass; by turning it anti-clockwise it is excluded.

1.25 Kits available on request.

- System shut off valves kit. The boiler is designed for installation of system interception cocks to be placed on flow and return pipes of the connection assembly. This kit is particularly useful for maintenance as it allows the boiler to be drained separately without having to empty the entire system.
- Polyphosphate dispenser kit. The polyphosphate dispenser reduces the formation of lime-scale and preserves the original heat exchange and domestic hot water production conditions. The boiler is prepared for application of the polyphosphate dispenser kit.
- Cover kit. For outdoor installations, in partially protected areas and with direct air intake, the top protection cover must be fitted for a correct functioning of the boiler and to protect it from storms (Fig. 11). For indoor installations, type B configuration, a suitable top protection cover coupled with the flue exhaust kit must be fitted.
- Anti freeze kit with resistance (on request). If the boiler is installed in a place where the temperature falls below -5°C and in the event there is no gas, the appliance can freeze. To prevent freezing of the domestic hot water system, an anti freeze kit with an electrical resistance can be fitted from the relative cable and from a control thermostat.

The above-mentioned kits are supplied complete with instructions for assembly and use. Check the complete list of kits available and which can be combined with the product, consult the Immergas website, the Immergas Price List or the technical-commercial documentation (catalogues and data sheets).

Head available to the system.

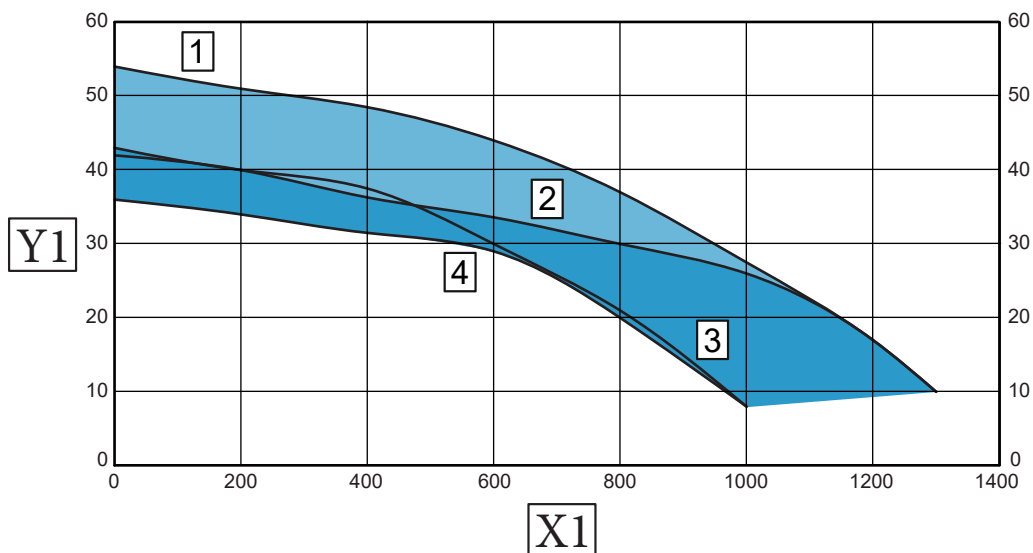

Key:

- 1 = Head available to the system at speed 3 with by-pass closed
 - 2 = Head available to the system at speed 3 with by-pass open
 - 3 = Head available to the system at speed 2 with by-pass closed
 - 4 = Head available to the system at speed 2 with by-pass open
- Area between curves 1 and 3 = Available system head with by-pass closed
 Area between curves 2 and 4 = Available system head with by-pass open
 X1 = Flow rate (l/h)
 Y1 = Head (kPa)

1.26 Boiler components.

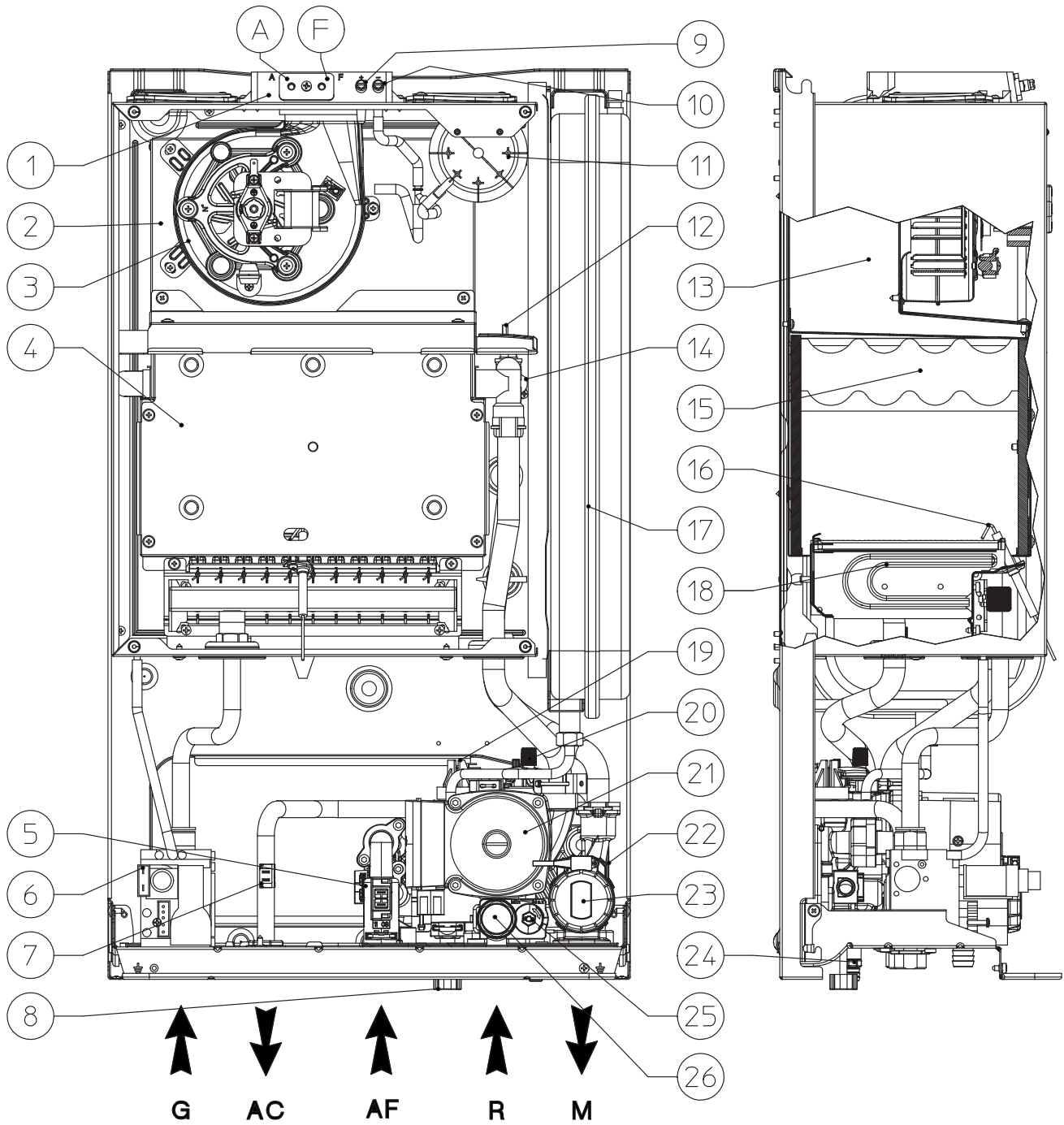

Key:

- | | | |
|--|--|----------------------------------|
| 1 - Sample points (air A) - (flue gas F) | 10 - Negative signal pressure point | 19 - System pressure switch |
| 2 - Sealed Chamber | 11 - Flue pressure switch | 20 - Vent valve |
| 3 - Fan | 12 - Delivery probe | 21 - Boiler pump |
| 4 - Combustion chamber | 13 - Fumes hood | 22 - Plate heat exchanger |
| 5 - Domestic hot water flow switch | 14 - Safety thermostat | 23 - Three-way valve (motorised) |
| 6 - Gas valve | 15 - Primary heat exchanger | 24 - System draining valve |
| 7 - Domestic hot water probe | 16 - Ignition and detection electrodes | 25 - By-pass |
| 8 - System filling valve | 17 - System expansion vessel | 26 - 3 bar safety valve |
| 9 - Positive signal pressure point | 18 - Burner | |

N.B.: connection group (optional)

INSTALLER

USER

MAINTENANCE TECHNICIAN

TECHNICAL DATA

2 INSTRUCTIONS FOR USE AND MAINTENANCE.

2.1 General warnings.

ATTENTION:

- Never expose the wall-mounted boiler to direct vapours from a cooking surface. 
- The device can be used by children at least 8 years old as well as by persons with reduced physical, sensory or mental capabilities, or lack of experience or required knowledge, provided that they are under surveillance, or after they have been instructed relating to the safe use and have understood the potential dangers. Children must not play with the appliance. Cleaning and maintenance destined to be performed by the user can not be carried out by unsupervised children.
- For safety purposes, check that the air intake/flue exhaust terminals (if fitted) are not blocked.
- If temporary shutdown of the boiler is required, proceed as follows:
 - a) drain the heating system if antifreeze is not used;
 - b) shut-off all electrical, water and gas supplies.
- In the case of work or maintenance to structures located in the vicinity of ducting or devices for flue extraction and relative accessories, switch off the appliance and on completion of operations ensure that a qualified technician checks efficiency of the ducting or other devices.
- Never clean the appliance or connected parts with easily flammable substances.
- Never leave containers or flammable substances in the same environment as the appliance.

- Do not open or tamper with the appliance. 
- Do not take apart or tamper with the intake and exhaust pipes.
- Only use the user interface devices listed in this section of the booklet.
- Do not climb on the appliance, do not use the appliance as a supporting surface.

ATTENTION:

- The use of components involving use of electrical power requires some fundamental rules to be observed such as: 
- do not touch the appliance with wet or moist parts of the body; do not touch it when bare-foot;
 - never pull electrical cables or leave the appliance exposed to atmospheric agents (rain, sunlight, etc.);
 - the appliance power cable must not be replaced by the user;
 - in the event of damage to the cable, switch off the appliance and contact exclusively qualified staff for replacement;
 - if the appliance is not to be used for a certain period, disconnect the main power switch.

ATTENTION:

water at a temperature of more than 50 °C can cause serious burns. Always check the water temperature before any use. 

The temperatures indicated by the display have a tolerance of +/- 3°C due to environmental conditions that cannot be blamed on the boiler. 

ATTENTION:



if you smell gas in the building:

- close the gas meter interception device or the main interception device;
- if possible, close the gas interception cock on the product;
- if possible, open doors and windows wide and create an air current;
- do not use open flames (e.g. lighters, matches);
- do not smoke;
- do not use electrical switches, plugs, door bells, telephones or intercom devices in the building;
- call an authorised company (e.g. Authorised After-Sales Service).

ATTENTION:



if you smell burning or see smoke coming out of the appliance, switch it off, disconnect power, close the main gas cock, open the windows and call an authorised company (e.g. Authorised After-Sales Service).

ATTENTION:



At the end of its service life, the appliance must not be disposed of like normal household waste nor abandoned in the environment, but must be removed by a professionally authorised company as required by current legislation. Contact the manufacturer for disposal instructions.

INSTALLER

USER

MAINTENANCE TECHNICIAN

TECHNICAL DATA

2.2 Cleaning and maintenance.

To preserve the boiler's integrity and keep the safety features, performance and reliability, which distinguish it, unchanged over time, you must execute maintenance operations on a yearly basis in compliance with what is stated in the relative point at "annual check and maintenance of the appliance" within the limits established by the Law.



2.3 Controlpanel.

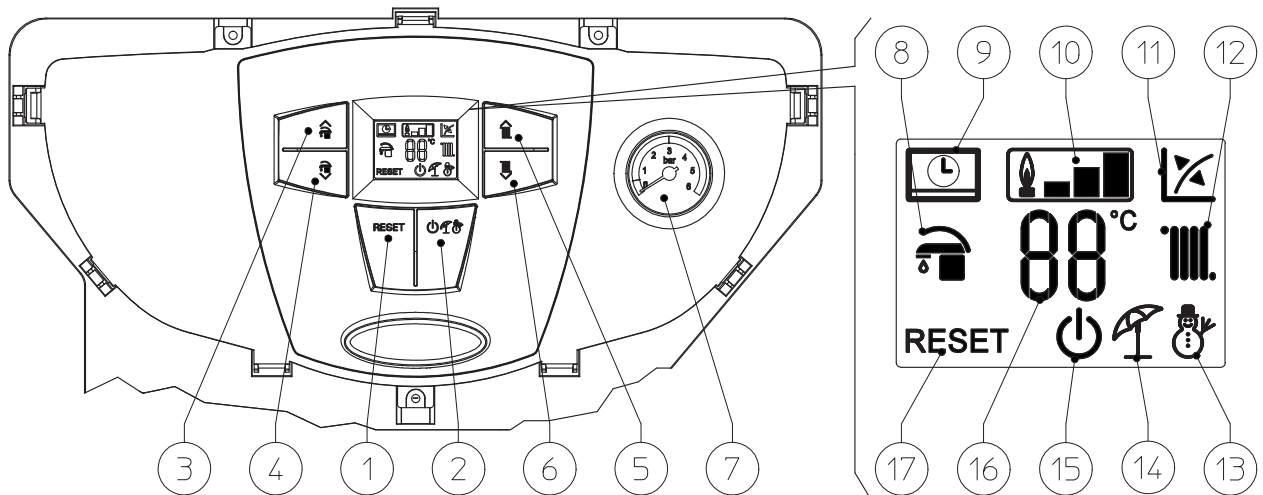

Key:

- | | |
|---|--|
| 1 - Reset button | 9 - Boiler connected to remote control (optional) |
| 2 - Stand-by/Off/Summer/Winter button | 10 - Flame presence symbol and relative power scale |
| 3 - (↑) button to increase the domestic hot water temperature | 11 - Functioning with external temperature probe active (optional) |
| 4 - (↓) button to decrease the domestic hot water temperature | 12 - Functioning room central heating phase active |
| 5 - (↑) button to increase the system water temperature | 13 - Functioning in winter mode |
| 6 - (↓) button to decrease the system water temperature | 14 - Functioning in summer mode |
| 7 - Boiler manometer | 15 - Boiler in Stand-by mode |
| 8 - Functioning DHW production phase active | 16 - Temperatures and error code display |
| | 17 - Boiler in block does not require release via "Reset" button |

2.4 Ignition of the boiler.

Before ignition make sure the heating system is filled with water and that the manometer (7) indicates a pressure of $1 \div 1.2$ bar.

- Open the gas cock upstream from the boiler.
- Press the button (2) until the display switches on, after which press the button in sequence (2) and take the boiler to the summer (☀️) or winter (❄️) position.
- **Summer (☀️)**: in this mode the boiler functions only to heat the DHW, the temperature is set via the buttons (3-4) and the relative temperature is shown on the display via the indicator (16).
- **Winter (❄️)**: in this mode the boiler functions both for heating domestic hot water and heating the environment. The temperature of the DHW is always regulated via buttons (3-4), the heating temperature is regulated via buttons (5-6) and the relative temperature is shown on the display via the indicator (16).

From this moment the boiler functions automatically. With no demand for heat (central heating or domestic hot water production) the boiler goes to “standby” function, equivalent to the boiler being powered without presence of flame. Each time the boiler ignites, the relative flame present symbol is displayed (10) with relative power scale.

- **Operation with Comando Amico Remoto^{V2} remote control (CAR^{V2}) (Optional)**. If the CAR^{V2} is connected, the (🔌) symbol will appear on the display. The boiler regulation parameters can be set via the CAR^{V2} control panel and the reset button (1) remains active on the boiler control panel, along with the switch-off button (2) (“off” mode only) and the display where the functioning state is shown.

ATTENTION:  **if the boiler is put into “off” mode on the CAR^{V2} the “CON” connection error symbol will appear on the CAR^{V2}. The CAR^{V2} is however powered constantly so as not to lose memorised programs.**

- **Functioning with optional external probe (🌡️)**. In the case of a system with optional external probe, the boiler flow temperature for room central heating is managed by the external probe depending on the external temperature measured (Par. 1.10). The flow temperature can be modified by selecting the functioning curve via buttons (5 and 6), selecting a value from “0 to 9” (Fig. 33).

With external probe present, the relative symbol will appear on the display (11). In the central heating phase, if the temperature of the water contained in the plant is sufficient to heat the radiators, the boiler can only function with the activation of the boiler pump.

- **“Stand-by” mode**. Press button (2) in succession until the (🔌) symbol appears. The boiler remains active from this moment and the anti-freeze function, pump anti-block function and 3-way and signalling of any anomalies is guaranteed.

ATTENTION:  **in “Stand-by” and “Off” mode, the boiler is still powered.**

- **“Off” mode**. By holding the button (2) down for 8 seconds, the display switches-off and the boiler is off completely. The safety functions are not guaranteed in this mode.

ATTENTION:  **in “Stand-by” and “Off” mode, the boiler is still powered.**

- **Display functioning**. The display lights up during the use of the control panel, after 15 seconds inactivity, the brightness drops until just the active symbols are displayed. The lighting mode can be varied via parameter P2 in the circuit board customisation menu.

2.5 Fault and anomaly signals.

The boiler signals out anomalies by flashing on the display and relative error codes, listed on the table, are displayed.

Error Code	Anomaly signalled	Cause	Boiler status / Solution
01	No ignition block	In the event of request of room central heating or domestic hot water production, the boiler does not switch on within the preset time. Upon appliance commissioning or after extended down-time, it may be necessary to eliminate the block.	Press the Reset button (1).
02	Safety thermostat block (over-temperature), flame control anomaly	During normal operation, if a fault causes excessive overheating internally, the boiler goes into overheating block.	Press the Reset button (1).
03	Fan anomaly	This occurs if the fan is blocked or if the intake or drain pipes are obstructed.	If normal conditions are restored the boiler restarts without having to be reset (1).
04	General boiler board anomaly	This takes place if the boiler board microprocessor erroneously recognises a signal.	Press the Reset button (1).
05	Flow probe anomaly	The board detects an anomaly on the flow probe.	The boiler does not start (1).
06	Domestic hot water probe anomaly	The board detects an anomaly on the domestic hot water NTC probe.	In this case the boiler continues to produce domestic hot water but not with optimal performance (1). Moreover, the anti-freeze function is prevented and an authorised company must be called.
08	Maximum N° of reset	Number of allowed resets that have already performed.	Attention: the Anomaly can be reset 5 times consecutively, after which the function is inhibited for at least one hour. One attempt is gained every hour for a maximum of 5 attempts. By switching the appliance on and off the 5 attempts are re-acquired.
10	Insufficient system pressure	Water pressure inside the central heating circuit that is sufficient to guarantee the correct operation of the boiler is not detected.	Check on the boiler pressure gauge (1) that the system pressure is between 1÷1.2 bar and restore the correct pressure if necessary.
11	Flue pressure switch failure	This occurs in case of a fault in the flue pressure switch or the fan.	If normal conditions are restored the boiler restarts without having to be reset (1).
15	Configuration error	If the board detects an anomaly or incongruity on the electric wiring, the boiler will not start.	If normal conditions are restored the boiler restarts without having to be reset. Check that the boiler is configured correctly (1).
20	Parasite flame	This occurs in the event of a leak on the detection circuit or anomaly in the flame control unit.	Press the Reset button (1).
24	Push button control panel anomaly	The board detects an anomaly on the pushbutton panel.	If normal conditions are restored the boiler restarts without having to be reset (1).
27	Insufficient circulation	This occurs if there is overheating in the boiler due to insufficient water circulating in the primary circuit; the causes can be: - low system circulation; check that no shut-off devices are closed on the heating circuit and that the system is free of air (deaerated); - pump blocked; free the pump.	If normal conditions are restored the boiler restarts without having to be reset (1).

(1) If the block or anomaly persists, contact an authorised company (e.g. Authorised Technical After-Sales Service).

Error Code	Anomaly signalled	Cause	Boiler status / Solution
31	Loss of remote control communication	This occurs 1 minute after communication loss between the boiler and the remote control.	Switch the boiler on and off again (1).
37	Low power supply voltage	This occurs when the power supply voltage is lower than the allowed limits for the correct boiler operation.	If normal conditions are restored the boiler restarts without having to be reset (1).
38	Loss of flame signal	This occurs when the boiler is ignited correctly and the burner flame switches off unexpectedly; a new attempt at ignition is performed and if normal conditions are restored, the boiler does not have to be reset.	(1).
43	Block due to loss of continuous flame signal	This occurs if the "Flame signal loss" error occurs 6 times consecutively in 8.5 minutes.	Press the Reset button (1).

(1) If the block or anomaly persists, contact an authorised company (e.g. Authorised Technical After-Sales Service).

2.6 Information Menu.

Pressing the buttons (3 and 4) for 5 seconds, the "Information menu" is activated, which allows to display some boiler functioning parameters.

To scroll through the various parameters, press (3 and 4), to exit from the menu press buttons (3 and 4) again for 5 seconds or press button (2) for 5 seconds or wait for 60 seconds.

Id Parametro	Descrizione
d1	Displays the flame signal (uA)
d2	Displays the primary exchanger output instant heating flow temperature
d3	Displays the instant output temperature from the DHW exchanger
d4	Displays the temperature set for the central heating set (if remote control is present)
d5	Displays the temperature set for the DHW set (if remote control is present)
d6	Displays the external environment temperature (if external probe is present). If the temperature is below zero, the value is displayed flashing.

2.7 Boiler shutdown.

For complete boiler switch-off, press the “off” button.

ATTENTION:

In these conditions the boiler is to be considered still live.



Disconnect the omnipolar switch outside the boiler and close the gas cock upstream of the appliance. Never leave the boiler switched on if left unused for prolonged periods.

In case of prolonged inactivity (second house), we also recommend that:

- the electric power supply is disconnected;
- empty the boiler domestic hot water circuit via the drain valves (Fig. 32) and the internal domestic hot water distribution network.

2.8 Restore central heating system pressure.

Periodically check the system water pressure. The boiler pressure gauge should read a value of between 1 and 1.2 bar.

If the pressure is below 1 bar (with the circuit cool) restore normal pressure via the filling cock located in the lower part of the boiler (Fig. 34).

N.B.: close the filling cock after the operation.

If pressure values reach around 3 bar the safety valve may be activated.

In this case ask for assistance from professionally qualified personnel.

In the event of frequent pressure drops, contact qualified staff for assistance to eliminate the possible system leakage.

2.9 Draining the system.

1. Ensure that the filling cock is closed.
2. Open the draining cock (Parag. 1.26).
3. Open all vent valves.
4. At the end, close the emptying cock.
5. Close all previously opened vent valves.

ATTENTION:

if glycol was input in the system's circuit, make sure it is discharged into the waste water system, pursuant to regulation EN 1717.



2.10 Anti-freeze protection.

The boiler has an anti-freeze function that switches on automatically when the temperature falls below 4°C (standard protection to minimum temperature of -5°C). In order to guarantee the integrity of the appliance and the domestic hot water heating system in zones where the temperature falls below zero, we recommend the central heating system is protected using anti-freeze liquid and installation of the Immergas Anti-freeze Kit in the boiler (Par. 1.4). In the case of prolonged inactivity (second case), we also recommend that:

- disconnect the electric power supply;
- the central heating circuit and boiler domestic hot water circuit must be drained. In systems that are drained frequently, filling must be carried out with suitably treated water to eliminate hardness that can cause lime-scale.

2.11 Draining the domestic hot water circuit.

To do this, always close the domestic cold water inlet upstream of the appliance.

Open any domestic hot water tap to discharge the pressure from the circuit.

2.12 Cleaning the case.

Use damp cloths and neutral detergent to clean the boiler casing. Never use abrasive or powder detergents.

2.13 Decommissioning.

In the event of permanent shutdown of the boiler, contact professional staff for the procedures and ensure that the electrical, water and gas supply lines are shut off and disconnected.

Bottom view.

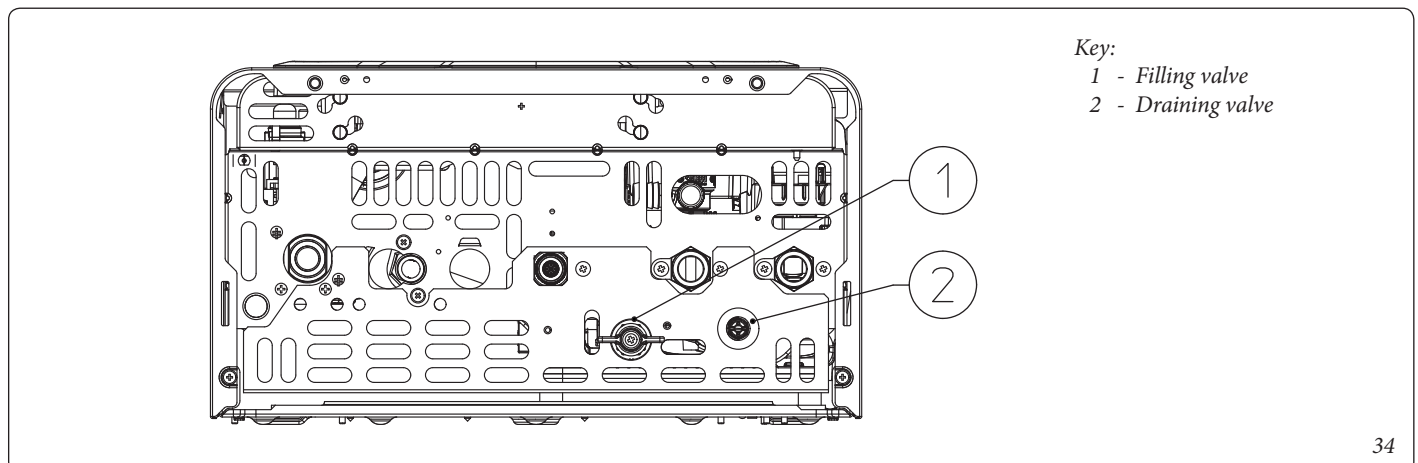

Key:

1 - Filling valve

2 - Draining valve

3 INSTRUCTIONS FOR MAINTENANCE AND INITIAL CHECK.

3.1 General warnings.

ATTENTION:

operators who install and service the appliance must wear the personal protective equipment (PPE) required by applicable law.

Note: the list of possible PPE is not complete as they are indicated by the employer.



ATTENTION:

before performing any maintenance operation, make sure:

- you have disconnected the power to the appliance;
- you have closed the gas cock;
- you have discharged the pressure from the system and domestic hot water circuit.



Supply of spare parts.

The device's warranty shall be rendered null and void if unapproved or unsuitable parts are used for maintenance or repairs. These will also compromise the product's compliance, and the said product may no longer be valid and fail to meet the current regulations.

With regard to the above, only use Immergas original spare parts when replacing parts.



If additional documentation needs to be consulted for extraordinary maintenance, contact the Authorised After-Sales Service.



3.2 Initial check.

To commission the boiler:



- ensure that the declaration of conformity of installation is supplied with the appliance;
- make sure that the type of gas used corresponds to boiler settings (the type of gas is displayed on the data nameplate and in the relevant P01 parameter);
- check connection to a 230V ~ 50Hz power mains, correct L-N polarity and the earthing connection;
- make sure the central heating system is filled with water and that the boiler manometer indicates a pressure of 1÷1.2 bar;
- make sure the air valve cap is open and that the system is well deaerated;
- switch the boiler on and ensure correct ignition;
- check the CO₂ flow rate in the flue:
 - maximum;
 - minimum;
- the values comply with the relevant tables (Par. 3.3);
- check activation of the safety device in the event of no gas, as well as the relative activation time;
- check activation of the main switch located upstream from the boiler;
- check that the intake and/or exhaust terminals are not blocked;
- check activation of the “no air” safety pressure switch;
- ensure activation of all adjustment devices;
- seal the gas flow regulation devices (if the settings are changed);
- ensure production of domestic hot water;
- check the tightness of the hydraulic circuits;
- check ventilation and/or aeration of the installation room where provided.

Even if just one single safety check provides a negative result, do not commission the system.

INSTALLER

USER

MAINTENANCE TECHNICIAN

TECHNICAL DATA

3.3 Yearly appliance check and maintenance.

The following checks and maintenance should be performed at least once a year to ensure operation, safety and efficiency of the appliance over time.



- Clean the flue side of the heat exchanger.
- Clean the main burner.
- Visually check the flue hood for deterioration or corrosion.
- Check correct lighting and operation.
- Ensure correct calibration of the burner in domestic water and central heating phases.
- Check correct operation of control and adjustment devices and in particular:
 - activation of the main switch located outside the boiler;
 - system control thermostat intervention;
 - domestic hot water control thermostat intervention.
- Check sealing efficiency of gas circuit and the internal system; after 10 years of operation, it is necessary to replace the gas valve, then checking the tightness of the gas circuit.
- Check the intervention of the device against no gas ionisation flame control. Intervention time must be less than 10 seconds.
- Check for water leaks or oxidation from/on the fittings.
- Visually check that the drain of the water safety valves is not blocked.
- Check that, after discharging system pressure and bringing it to zero (read on boiler pressure gauge), the expansion vessel load is at 1.0 bar.
- Check that the system static pressure (with system cold and after refilling the system by means of the filling valve) is between 1 and 1.2 bar.
- Check visually that the safety and control devices have not been tampered with and/or shorted, in particular:
 - temperature safety thermostat;
 - water pressure switch;
 - flue pressure switch.
- Check the condition and integrity of the electrical system and in particular:
 - the power supply wires must be housed in the cable glands;
 - there must be no traces of blackening or burning.

	CO ₂ at Nominal Q.	CO ₂ at Minimum Q.
G 20	6.4% (-±-)	2.4% (-±-)
G 31	7.2% (-±-)	2.8% (-±-)

	O ₂ at Nominal Q.	O ₂ at Minimum Q.
G 20	9.4% (-±-)	16.6% (-±-)

In addition to yearly maintenance, one must also check the energy efficiency of the thermal system, with frequency and procedures that comply with the indications of the technical regulations in force.



3.4 Boiler Hydraulic diagram.

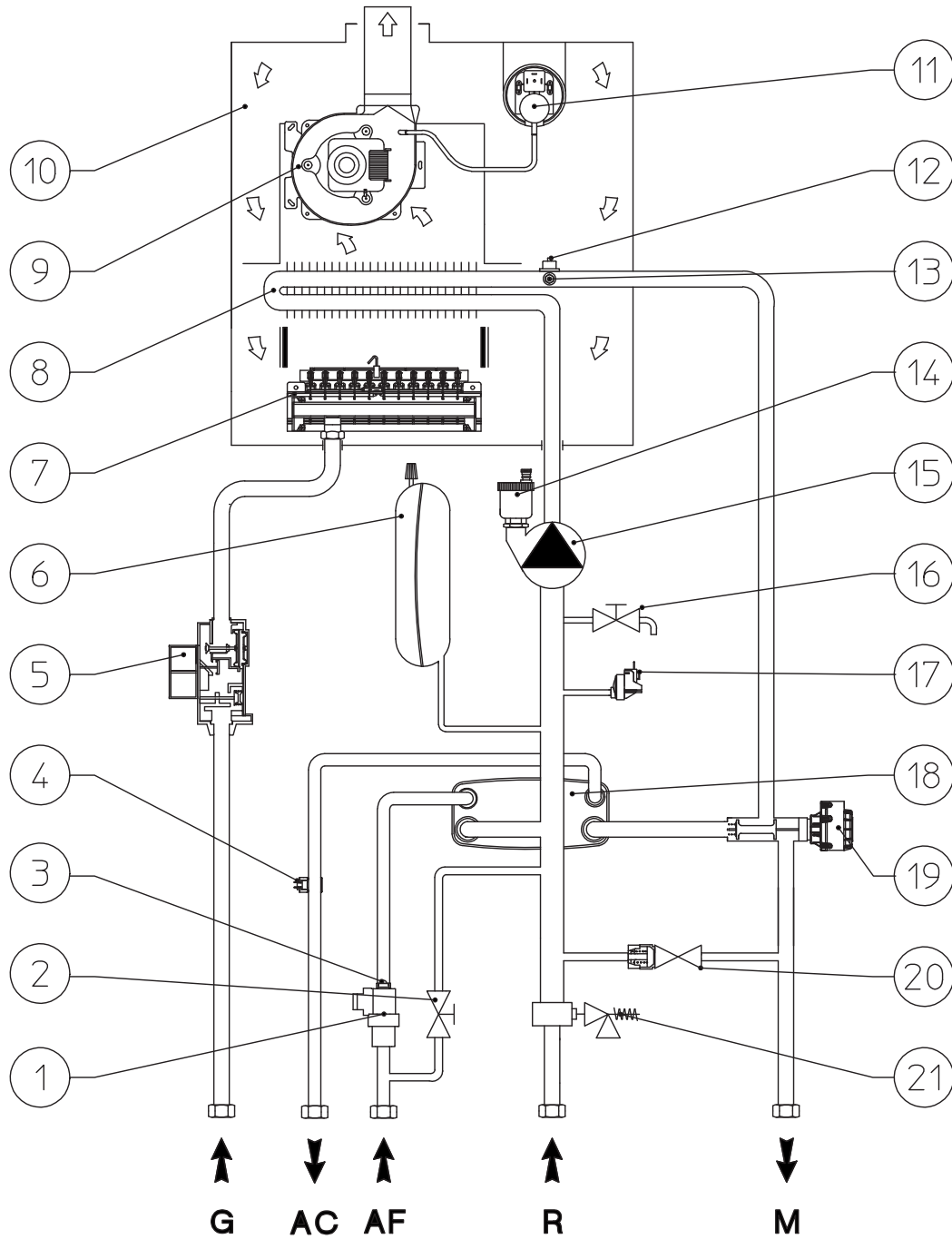

Key:

- 1 - Domestic hot water flow switch
- 2 - System filling valve
- 3 - Flow limiter
- 4 - Domestic hot water probe
- 5 - Gas valve
- 6 - System expansion vessel
- 7 - Burner
- 8 - Primary heat exchanger
- 9 - Fan
- 10 - Sealed chamber
- 11 - Flue pressure switch
- 12 - Flow probe
- 13 - Safety thermostat
- 14 - Air vent valve

- 15 - Boiler pump
 - 16 - System draining valve
 - 17 - System pressure switch
 - 18 - Plate heat exchanger
 - 19 - 3-way valve (motorised)
 - 20 - By-pass
 - 21 - 3 bar safety valve
- G - Gas supply
 AC - Domestic hot water outlet
 AF - Domestic hot water inlet
 R - System return
 M - System flow

INSTALLER

USER

MAINTENANCE TECHNICIAN

TECHNICAL DATA

3.5 Wiring diagram.

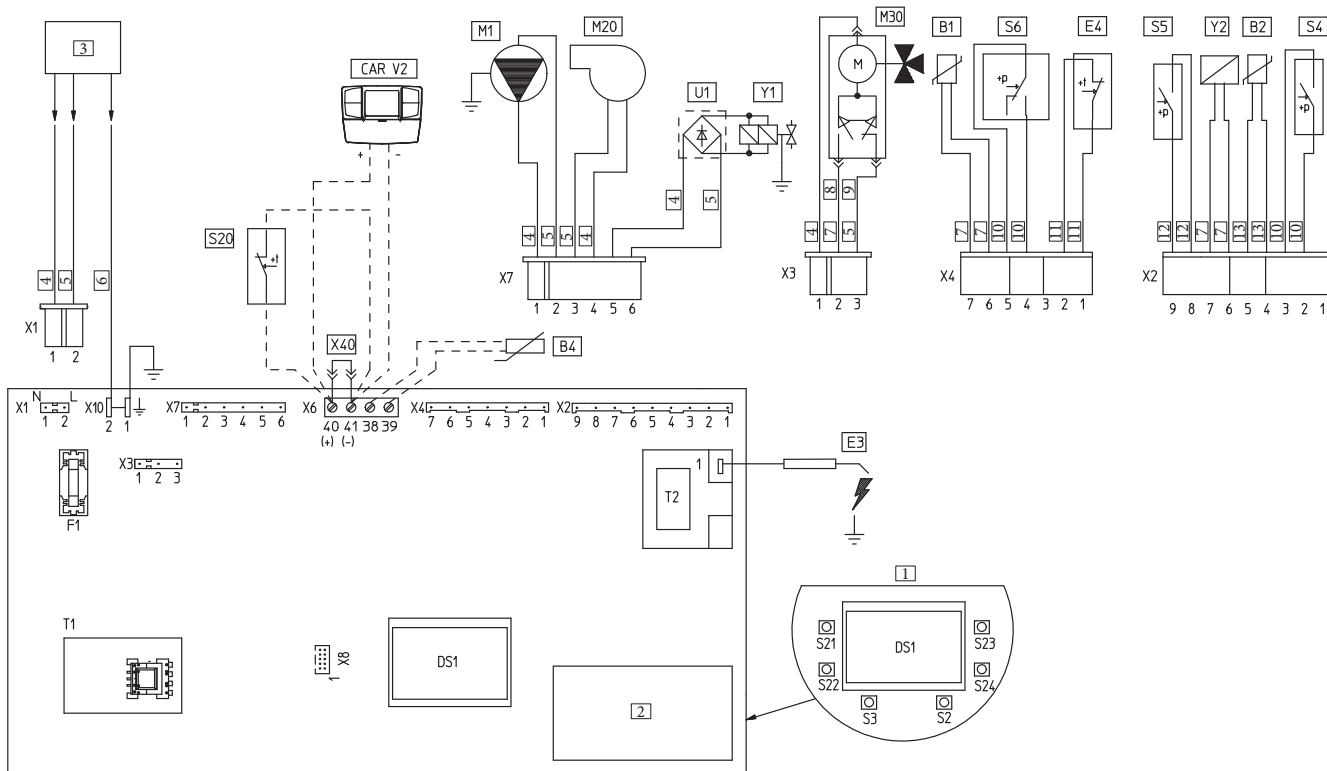

Key:

B1 - Flow probe	S20 - Room thermostat (optional)	1 - User interface
B2 - Domestic hot water probe	S21 - Key to increase DHW temperature	2 - N.B.: The user interface is on the welding side of the boiler board
B4 - External probe	S22 - Key to decrease DHW temperature	3 - 230 Vac 50Hz power supply
CAR ^{V2} - Comando Amico Remoto remote control Version 2 (optional)	S23 - Key to increase central heating temperature	4 - Blue
DS1 - Display	S24 - Key to decrease central heating temperature	5 - Brown
E3 - Ignition and detection electrodes	T1 - Low voltage feeder	6 - Yellow/Green
E4 - Safety thermostat	T2 - Ignition transformer	7 - Black
F1 - Phase fuse	U1 - Rectifier inside the gas valve connector (Only available on Honeywell gas valves)	8 - Domestic hot water
M1 - Boiler pump	Y1 - Gas valve	9 - Central heating
M20 - Fan	Y2 - Gas valve modulator	10 - Grey
M30 - Three-way valve		11 - White
S2 - Selector switch functioning		12 - Red
S3 - Reset block key		13 - Green
S4 - Domestic hot water flow switch		
S5 - System pressure switch		
S6 - Flue pressure switch		

36

The boiler is designed for application of a room thermostat (S20), an On/Off room chronothermostat, a program timer or a Comando Amico Remoto^{V2} remote control (CAR^{V2}). Connect to clamps 40 - 41 eliminating the jumper X40, paying attention not to invert the polarity if the CAR^{V2} is installed.

The connector X8 is used for the connection of the Virgilio Palm-top in the microprocessor software updating operation.

3.6 Possible problems and their causes.

Maintenance interventions must be carried out by an authorised company (e.g. Authorised After-Sales Technical Assistance Service).



Trouble	Possible causes	Solutions
Smell of gas	Caused by leakage from gas circuit pipelines	Check sealing efficiency of gas intake circuit.
The fan works but ignition discharge does not occur on the burner ramp	The fan may start but the safety air pressure switch does not switch the contact over.	Make sure: 1) the intake-exhaust duct is not too long (over allowed length). 2) the intake-exhaust pipe is not partially blocked (on the exhaust or intake side). 3) the diaphragm of the fume exhaust is adequate for the length of the intake-exhaust duct. 4) the sealed chamber is kept in good conditions. 5) the fan power supply voltage is not less than 196 V.
Irregular combustion (red or yellow flame).	Can be caused by: dirty burner, clogged lamellar pack, intake - exhaust terminal not installed properly.	Clean the above components and ensure correct installation of the terminal.
Frequent activation of the temperature overload thermostat	It can depend on reduced water pressure in the boiler, little circulation in the heating system, the blocked pump or an anomaly of the boiler P.C.B.	- Check on the pressure gauge that the system pressure is within established limits. - Check that radiator valves are not all closed.
Abnormal noises in the system	Air in the system.	- Check opening of the special air vent valve cap (Fig. 32). - Make sure the system pressure and expansion vessel factory-set pressure values are within the set limits; the factory-set value for the expansion vessel must be 1.0 bar, and system pressure between 1 and 1.2 bar.
Ignition block	In the event of request of room central heating or domestic hot water production, the boiler does not switch on within the preset time. Upon appliance commissioning or after extended downtime, it may be necessary to eliminate the block.	Press the Reset button.
Presence of condensation on the boiler.	It can be determined by functioning at boiler temperatures that are excessively low.	In this case, make the boiler run at higher temperatures.

INSTALLER

USER

MAINTENANCE TECHNICIAN

TECHNICAL DATA

3.7 Converting the boiler to other types of gas.

The gas conversion operation must be carried out by an authorised company (e.g. Authorised Technical Assistance Service).



If the appliance needs to be converted to a different gas type to that specified on the data plate, request the relative conversion kit for quick and easy conversion.

To convert to another type of gas the following operations are required:

- disconnect power to the appliance;
- replace the main burner injectors, making sure to insert the special seal rings supplied in the kit, between the gas manifold and the injectors;
- re-power the appliance;
- use the boiler push button control panel to select the gas parameter type (G1) and select (Ng) in case of Methane supply or (Lg) in the case of LPG;
- adjust the boiler nominal heat output;
- adjust the boiler minimum heat power;
- adjust the boiler minimum heat output in heating phase;
- adjust (eventually) the maximum heating power (Parag. 3.8 parameter P5);
- seal the gas flow rate regulation devices (if settings are modified);
- after completing the conversion, apply the sticker, contained in the conversion kit, near the data nameplate. Using an indelible marker pen, delete the data relative to the old type of gas.

These adjustments must be made with reference to the type of gas used, following the indications given in the table (Par. 4.1/4.4).

Checks following conversion to another type of gas.

After making sure that conversion was carried out with a nozzle of suitable diameter for the type of gas used and the settings are made at the correct pressure, check that:

- there is no flame in the combustion chamber;
- the burner flame is not too high or low and that it is stable (does not detach from burner);

ATTENTION:

The pressure testers used for calibration should be perfectly closed and there should be no leaks from the gas circuit.



Maintenance interventions must be carried out by an authorised company (e.g. Authorised After-Sales Technical Assistance Service).



Burner adjustment must be carried out using a differential "U" or digital type pressure gauge connected to the pressure socket located above the sealed chamber and the gas valve pressure point, keeping to the pressure value given in the table according to the type of gas for which the boiler is prepared.

SIT 845 GAS valve

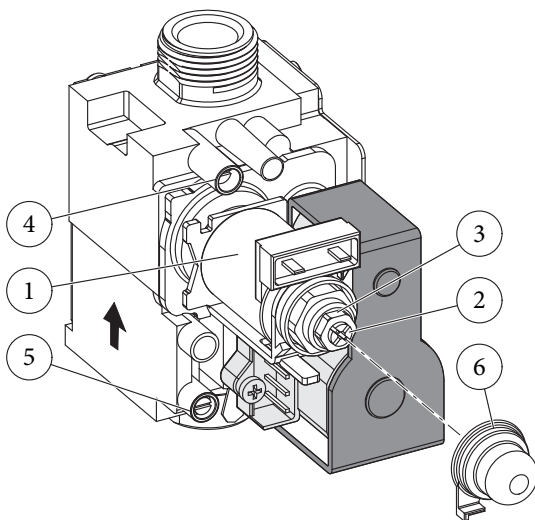

VK 4105 M GAS valve

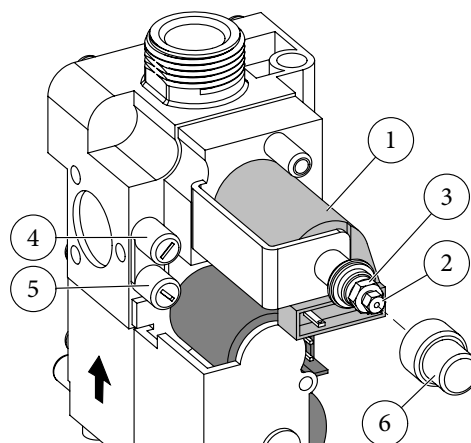

Key:

- 1 - Coil
- 2 - Minimum power adjustment nut
- 3 - Maximum power adjustment nut
- 4 - Gas valve outlet pressure point
- 5 - Gas valve inlet pressure point
- 6 - Protection hood

3.8 Programming the P.C.B.

The boiler is prepared for possible programming of several operation parameters. By modifying these parameters as described below, the boiler can be adapted according to specific needs.

To access the programming phase, proceed as follows (references Fig. 33):

- press buttons (1) and (2) at the same time for approximately 8 seconds;
- using keys (3) and (4), select the parameter to be changed indicated in the following table:

- adjust the corresponding value consulting the table using keys (5) and (6);
 - confirm the value set by pressing the Reset button (1) for about 3 seconds; by pressing keys (3) + and (4) - at the same time exit the function without memorising the modifications made.
- N.B.:** after a period of time, without touching any keys, the operation cancels automatically.

Id Parameter	Parameter	Description	Range (ref. 16 Fig. 33)	Default
P1	Boiler mode (DO NOT USE)	It establishes whether the boiler functions in instant or storage mode.	0 - instant boiler 1 - Boiler with storage tank	0
P2	Display lighting	Establishes the display lighting mode: 0 = (Off) the display is always lit with low intensity 1 = (Auto) the display lights up during use and lowers after 5 seconds of inactivity. In the case of anomaly the display flashes. 2 = (On) the display is always lit with high intensity.	0 - Off 1 - Auto 2 - On	1
P3	DHW thermostat	With the "correlated" thermostat setting, boiler switch-off takes place on the basis of the temperature set. While with the setting of the "fixed" DHW thermostat the switch-off temperature is fixed at the maximum value independently from the value set on the control panel.	0 - Fixed 1 - Correlated	1
P4	Minimum CH output	The boiler also has electronic modulation that adapts the boiler potentiality to the effective heating demand of the house. Then the boiler works normally in a variable gas pressure field between the minimum heating output and the maximum heating output depending on the system's heating load. N.B.: the boiler is produced and calibrated in the central heating phase at nominal output. Approximately 10 minutes are needed to reach the nominal heat output, which can be changed using the parameter (P5). N.B.: the selection of the "Minimum heating output" and "Maximum heating output" parameters, in presence of a heating request, allows boiler ignition and power supply of the modulator with current equal to the value of the respective set value.	0 - 63 %	Set according to factory inspection
P5	Maximum CH output		0 - 99 %	99
P6	Central heating ignitions timer	The boiler has electronic timing, which prevents the burner from igniting too often in central heating mode.	0 - 20 (0 - 10 minutes) (01 equals 30 seconds)	6 (3')
P7	Central heating ramp timer	In the ignition phase, the boiler performs an ignition ramp in order to arrive at the maximum nominal power set.	0 - 28 (0 - 14 minutes) (01 equals 30 seconds)	28 (14')
P8	Heating switch-on delay request from room thermostat and remote control.	The boiler is set to switch-on immediately after a request. In the case of particular systems (e.g. area systems with motorised thermostatic valves etc.) it could be necessary to delay switch-on.	0 - 20 (0 - 10 minutes) (01 equals 30 seconds)	0 (0')
P9	Solar mode (DHW ignition delay)	The boiler is set to switch-on immediately after a request. for DHW In the case of coupling with solar storage tanks positioned upstream from the boiler, it is possible to compensate the distance of the storage tank in order to allow the hot water to reach the utility, setting the necessary time and therefore verifying that the water is hot enough (see Par. Solar panels coupling).	0 - 20 seconds	0

INSTALLER

USER

MAINTENANCE TECHNICIAN

TECHNICAL DATA

Id Parameter	Parameter	Description	Range (ref. 16 Fig. 33)	Default
G1	Gas type selection	The setting of this function is used to adjust the boiler in order to function with the correct type of gas.	nG - Methane lG - LPG Ci - China	The same as the type of gas being used
G2	Ignition power	To access this regulation, once having entered the programming mode, press the button (2) for 4 seconds. To exit, press button (2) again 4 seconds.	0 - 70 %	Set according to factory inspection

3.9 Possible adjustments.

N.B.: to adjust the gas valve, remove the plastic cap (6); after adjusting, refit the cap.

- Preliminary calibration operations.
 - Set parameter P4 at 0%.
 - Set parameter P5 at 99%.
- Activate the chimney sweep function.
 - Enter the “DHW chimney sweep” mode, opening a DHW cock.
- Adjustment of boiler nominal thermal heat output.
 - Set the maximum output (99%) using the buttons (5 and 6 Fig. 33).
 - Adjust the boiler nominal power on the brass nut (3 Fig. 37), keeping to the maximum pressure values stated in the tables (Par. 4.1) according to the type of gas; by turning clockwise the heat potential increases, anti-clockwise it decreases.

- Adjustment of boiler minimum thermal heat output.

N.B.: only proceed after having calibrated the nominal pressure.

- Set the minimum output (0%) always using the buttons (5 and 6 Fig. 33).
- Adjust the minimum thermal input by operating on the cross plastic screws (2) on the gas valve maintaining the brass nut blocked (3);

- Exit the “Chimney sweep” mode and keep the boiler functioning.
- Adjustment of the boiler minimum heat output in heating phase.

N.B.: only proceed after having calibrated the minimum boiler pressure.



- To adjust the minimum heat output during the heating phase, change parameter (P4), increasing the value the pressure increases, reducing it the pressure drops.
- The pressure to which the boiler minimum heat output must be adjusted, must not be lower than that stated in the tables (Par. 4.1/4.4).
- Adjustment (any) of the boiler maximum heat output in heating phase.
 - To adjust the maximum heat output during the heating phase, change parameter (5), increasing the value the pressure increases, reducing it the pressure drops.
 - The pressure to which the boiler maximum heat output must be adjusted in central heating phase, must not be carried out in reference to that stated in the tables (Par. 4.1/4.4)



3.10 Automatic slow ignition function with timed ramp delivery.

In ignition phase, the P.C.B. supplies constant gas with pressure proportional to the parameter “G2” set.

3.11 “Chimney sweep” function.

When activated, this function forces the boiler to variable output for 15 minutes.

In this state all adjustments are excluded and only the safety thermostat and the limit thermostat remain active. To activate the chimney sweep function, press the Reset button (1) for 8 seconds in absence of DHW requests, its activation is signalled by the indication of the flow temperature and the flashing  and  symbols.

This function allows the technician to check the combustion parameters. Once the function is activated, it is possible to select whether to perform the check in CH status, regulating the parameters with buttons (5 and 6) or in DHW mode opening any DHW cock and always regulate the parameters with the buttons (5 and 6). Functioning in CH or DHW mode is visualised by the relative flashing  or  symbols.

On completion of the checks, deactivate the function by pressing the Reset button (1) for 8 seconds.

3.12 Pump anti-block function.

The boiler has a function that starts the pump once every 24 hours for the duration of 30 seconds in order to reduce the risk of the pump becoming blocked due to prolonged inactivity.

3.13 Three-way anti-block system

The boiler is supplied with a function that activates the motorised three-way unit at least every 24 hours, carrying out a complete cycle in order to reduce the risk of three-way block due to prolonged inactivity.

3.14 Radiators anti-freeze function.

If the system return water is below 4°C, the boiler starts up until reaching 42°C.

3.15 P.C.B. periodical self-check.

During functioning in central heating mode or with boiler in standby, the function activates every 18 hours after the last boiler check/power supply. In case of functioning in domestic hot water mode the self-check starts within 10 minutes after the end of the withdrawing in progress, for duration of approx. 10 seconds.

During self-check, the boiler remains off, including signalling.



3.16 Solar panels coupling function.

The boiler is set-up to receive pre-heated water from a system of solar panels up to a maximum temperature of 65°C. In all cases, it is always necessary to install a mixing valve on the hydraulic circuit upstream from the boiler on the cold water inlet.

For good functioning of the boiler; the temperature selected on the solar valve must be 5°C greater with respect to the temperature selected on the boiler control panel.



For correct use of the boiler in this condition, parameter P3 (DHW thermostat) must be set at "1" and the parameter P9 (Solar mode (DHW ignition delay)) at a temperature sufficient to receive water from a storage tank situated upstream from the boiler. The greater the distance from the storage tank, the longer the stand-by time to be set. When these regulations have been performed, when the boiler inlet water is at the same or greater temperature with respect to that set by the DHW selector switch, the boiler does not switch on.

3.17 Casing removal.

To facilitate boiler maintenance the casing can be completely removed as follows (Fig. 38 / 39):

- 1 Unhook the decorative frame (a) from the relative lower retainers.
- 2 Remove the decorative frame (a) from the casing (c).
- 3 Loosen the 2 front screws (b) that fix the casing on.
- 4 Loosen the 2 lower screws (d) that fix the casing on.
- 5 Pull the case towards yourself (c).
- 6 Push the case (c) upwards at the same time to release it from the upper hooks.

Installation drawings key:

- Ⓐ Unmistakeable component identification
- ① Sequential identification of the operation to perform

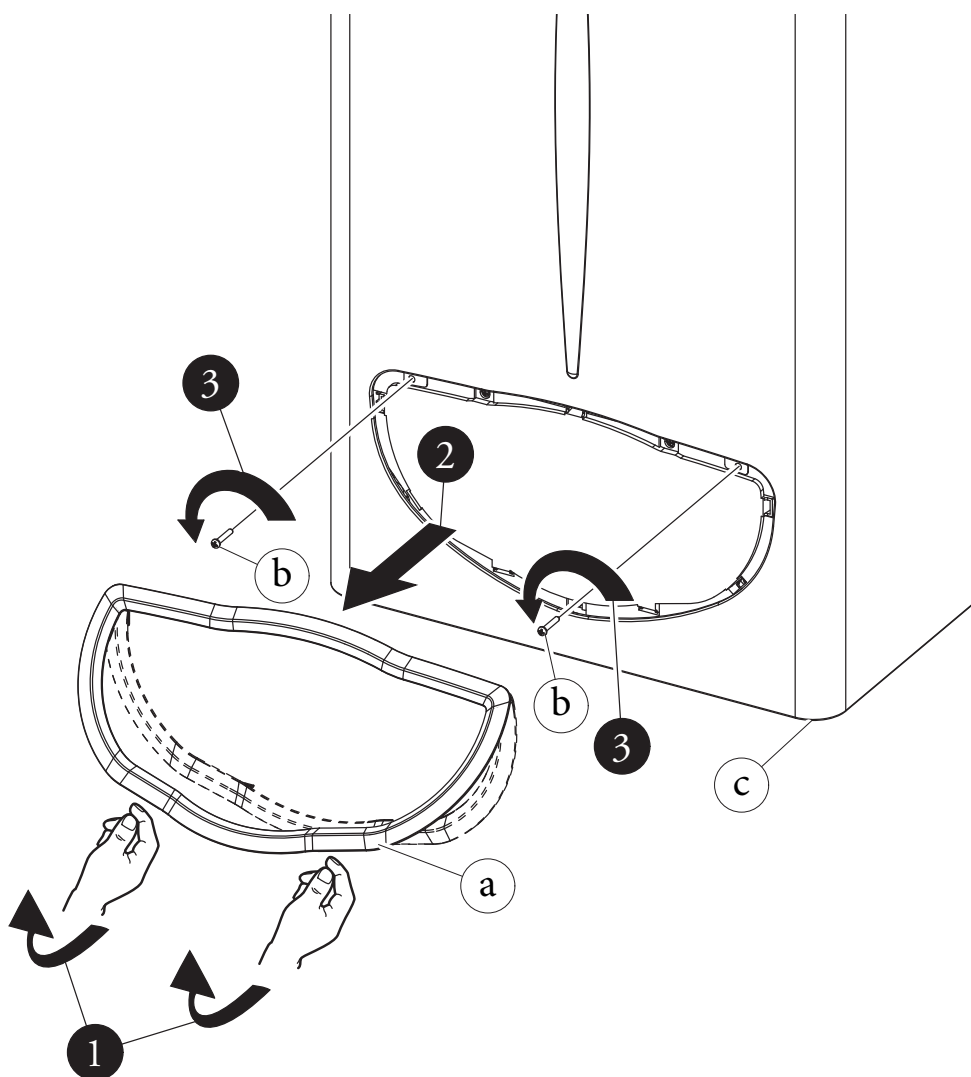

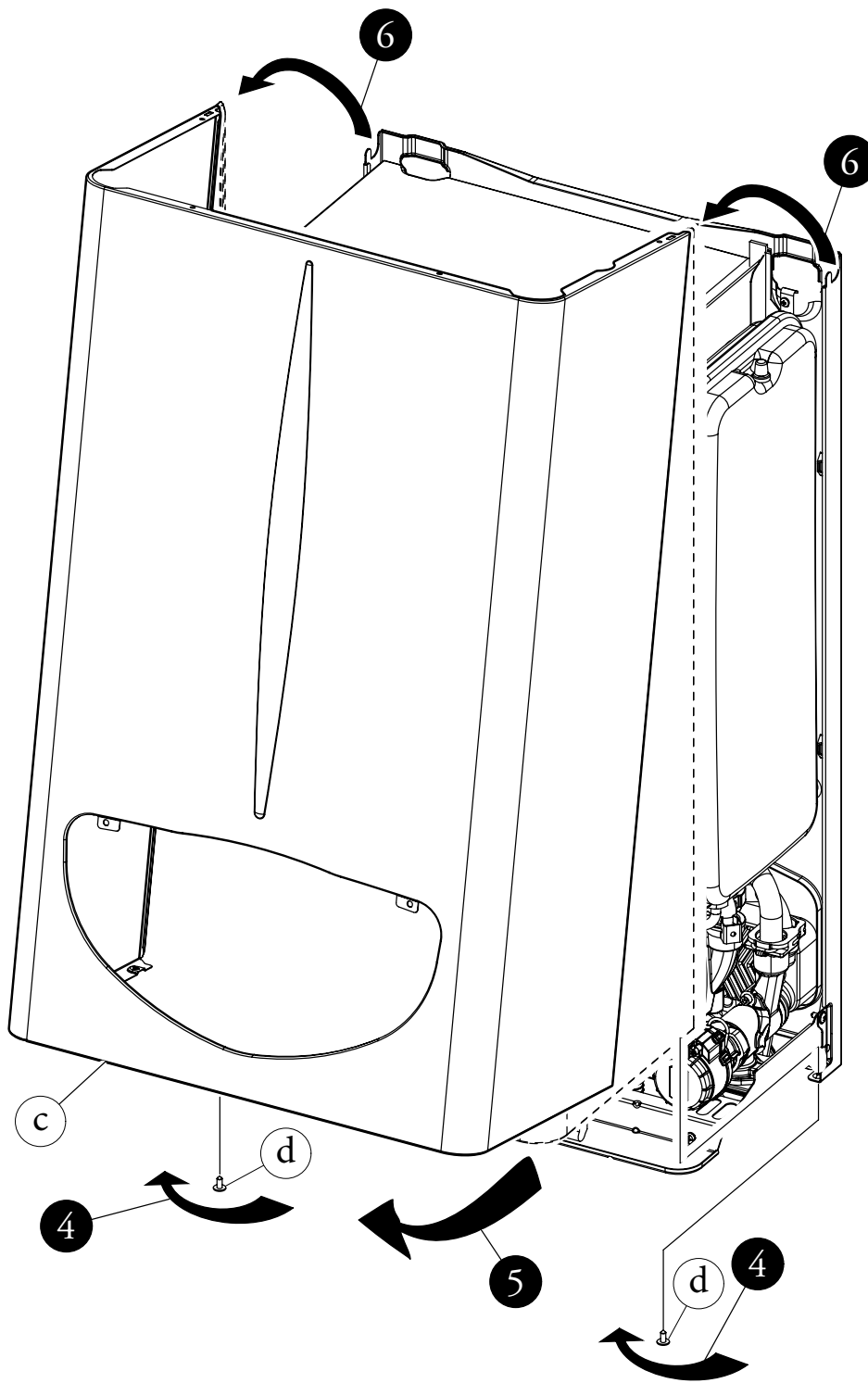

INSTALLER

USER

MAINTENANCE TECHNICIAN

TECHNICAL DATA

4 TECHNICAL DATA.

4.1 Variable heat output.

N.B.: the pressures indicated in the table represent the difference in existing pressures between the gas valve outlet and the combustion chamber. The adjustments should therefore, be carried out using a differential manometer (small "U"-shaped column or digital manometer) with the probes inserted in the pressure test gas valve

outlet and on the sealed chamber positive pressure test.

The power data in the table has been obtained with intake-exhaust pipe measuring 0.5 m in length. Gas flow rates refer to heating power below a temperature of 15°C and at a pressure of 1013 mbar. Burner pressure values refer to use of gas at 15°C.

HEAT INPUT	HEAT OUTPUT	METHANE (G20)			PROPANE (G31)		
		FAN REVS	MODULATION	BURNER GAS FLOWRATE	FAN REVS	MODULATION	BURNER GAS FLOWRATE
(kW)	(kW)	(rpm)	(%)	(m ³ /h)	(rpm)	(%)	(kg/h)
25.6	23.5	11.9	100	2.71	36.5	100	1.99
10.5	9.0	2.3	8	1.11	7.4	9	0.82
8.3	7.1	1.5	0	0.88	4.5	0	0.64

4.2 Combustion parameters.

		G20	G31
Gas nozzle diameter	mm	1.35	0.79
Supply pressure	mbar (mm H ₂ O)	20 (204)	37 (377)
Flue flow rate at heating nominal heat output	kg/h	57	58
Flue flow rate at min heat output	kg/h	59	58
CO ₂ at Nominal Q.	%	6.4	7.2
O ₂ at Nominal Q.	%	9.4	-
CO ₂ to minimum Q.	%	2.4	2,8
O ₂ to minimum Q.	%	16.6	-
CO at 0% of O ₂ at Nom. Q./Min.	ppm	89/90	81/106
NO _x at 0% of O ₂ at Nom.Q./Min.	mg/kWh	216/143	185/126
Flue temperature at nominal output	°C	135	136
Flue temperature at minimum output	°C	101	106

4.3 Technical data.

Nominal heat input	kW (kcal/h)	25.6 (22051)
DHW minimum heat input	kW (kcal/h)	8.3 (7117)
CH minimum heat input	kW (kcal/h)	10.5 (9057)
Nominal heat output (useful)	kW (kcal/h)	23.5 (20206)
DHW minimum heat output (useful)	kW (kcal/h)	7.1 (6104)
CH minimum heat output (useful)	kW (kcal/h)	9.0 (7738)
(*) Effective thermal efficiency 80/60 Nom./Min.	%	91.8/86.0
(*) Efficiency at 30% nominal heat output load	%	88.8
Heat loss at case with burner Off/On	W	153/156
Heat loss at flue with burner Off/On	W	15/1771
Central heating circuit max. operating pressure	bar	3
Central heating circuit max. operating temperature	°C	90
Adjustable central heating temperature	°C	35 - 85
System expansion vessel total volume	l	4
Expansion vessel factory-set pressure	bar	1
Water content in generator	l	2.5
Total head available with 1000 l/h flow rate	kPa	26.0
Domestic hot water adjustable temperature	°C	30 - 60
Nominal domestic hot water circuit flow limiter	l/min	8.0
Min. pressure (dynamic) domestic hot water circuit	bar	0.3
Domestic hot water circuit max. working pressure	bar	10
Minimum D.H.W. flow rate	l/min	1.5
Specific flow rate (ΔT 30°C)	l/min	11.2
Drawing capacity in continuous duty (ΔT 30°C)	l/min	-
Weight of full boiler	kg	34.5
Weight of empty boiler	kg	32.0
Electrical connection	V/Hz	230/50
Power input	A	0.66
Installed electric power	W	130
Equipment electrical system protection	-	IPX5D
Ambient operating temperature range	°C	0 ÷ 40
Maximum flue overheating temperature	°C	180
NO _x class	-	3
Weighted NO _x	mg/kWh	147
Weighted CO	mg/kWh	87
Type of appliance	C12 / C32 / C42 / C52 / C62 / C82 / B22p / B32	
Category	II2H3P	

- The data relevant to domestic hot water performance refers to a dynamic inlet pressure of 2 bar and an inlet temperature of 15°C; the values are measured directly at the boiler outlet considering that to obtain the data declared mixing with cold water is necessary.
- The max. sound level emitted during boiler operation is < 55dBA. The sound level value is referred to semianechoic chamber tests with boiler operating at max. heat output, with extension of flue gas exhaust system according to product standards.

- * The efficiency values refer to the lower calorific value.
- The weighted NO_x value refer to the net calorific value.

INSTALLER

USER

MAINTENANCE TECHNICIAN

TECHNICAL DATA

4.4 Key for Data nameplate.

Md.		Cod. Md.	
Sr N°	CHK	PIN	T.
Type			
Q _{nw} /Q _n min.	Q _{nw} /Q _n max.	P _n min.	P _n max.
PMS	PMW	D	TM
NO _x Class			

N.B.: the technical data are provided on the data plate on the boiler.

	ENG
Md	Model
Code Md	Model code
Sr N°	Serial Number
CHK	Check
PIN	PIN code
T.	Minimum and maximum installation temperature
Type	Type of installation (ref. CEN TR 1749)
Q _{nw} min.	Minimum DHW heat input
Q _n min.	Central heating minimum heat input
Q _{nw} max.	DHW maximum heat input
Q _n max.	Central heating maximum heat input
P _n min.	Minimum heat output
P _n max.	Maximum heat output
PMS	Maximum system pressure
PMW	Maximum domestic hot water pressure
D	Specific flow rate
TM	Maximum operating temperature
NO _x Class	NO _x Class



This instruction booklet
is made of ecological paper



immergas.com

Immergas S.p.A.
42041 Brescello (RE) - Italy
Tel. 0522.689011
Fax 0522.680617



IMMERGAS
IMMERGAS SPA - ITALY
CERTIFIED COMPANY
UNI EN ISO 9001:2015

Design, manufacture and post-sale assistance of gas
boilers, gas water heaters and related accessories

