

OWNER'S MANUAL



Instruction booklet and  IE  
warning

Installer

User

Maintenance Technician

# HERCULES SOLAR 26 2 ERP

\*1.037974ENG\*



## INDEX

Dear Customer.....	3	2	Instructions for use and maintenance.....	43
General recommendations.....	3	2.1	General warnings.....	43
Safety symbols used.....	5	2.2	Cleaning and maintenance.....	45
Personal protective equipment.....	5	2.3	Control panel.....	45
1 Boiler installation.....	6	2.4	Description of functioning states.....	46
1.1 Installation recommendations.....	6	2.5	Using the boiler.....	47
1.2 Main dimensions.....	9	2.6	Troubleshooting.....	49
1.3 Minimum installation distances.....	10	2.7	Parameters and information menu.....	52
1.4 Gas connection.....	11	2.8	Boiler shutdown.....	54
1.5 Hydraulic connection.....	12	2.9	Restore central heating system pressure.....	54
1.6 Solar circuit hydraulic connection.....	12	2.10	Draining the system.....	54
1.7 Electrical connection.....	13	2.11	Draining the domestic hot water circuit.....	54
1.8 Remote controls and room chrono-thermostats (Optional).....	15	2.12	Cylinder draining.....	54
1.9 External temperature probe (Optional).....	16	2.13	Antifreeze protection.....	54
1.10 Immergas flue systems.....	17	2.14	Case cleaning.....	55
1.11 Tables of resistance factors and equivalent lengths.....	18	2.15	Decommissioning.....	55
1.12 Installation of boiler type B with open chamber and fan assisted (optional).....	20	3	Instructions for maintenance and initial check.....	56
1.13 Concentric horizontal kit installation.....	21	3.1	General warnings.....	56
1.14 Concentric vertical Kit installation.....	23	3.2	Initial check.....	56
1.15 Separator kit installation.....	25	3.3	Yearly appliance check and maintenance.....	57
1.16 Adaptor C <sub>9</sub> kit installation.....	27	3.4	Plumbing diagram.....	58
1.17 Ducting of flues or technical slots.....	29	3.5	Wiring diagram.....	59
1.18 Configuration type B, open chamber and fan assisted for indoors.....	29	3.6	Troubleshooting.....	60
1.19 Flue exhaust to flue/chimney.....	29	3.8	Calibration of number of fan revs.....	61
1.20 Flues, chimneys and chimney caps.....	30	3.7	Converting the boiler to other types of gas.....	61
1.21 System filling.....	30	3.9	CO <sub>2</sub> adjustment.....	62
1.22 Filling the condensate drain trap.....	30	3.10	Checks following conversion to another type of gas.....	62
1.23 Gas system start-up.....	30	3.11	Programming the P.C.B.....	62
1.24 Solar circuit start-up.....	31	3.12	“Chimney sweep function”.....	66
1.25 Solar circuit filling.....	32	3.13	Pump anti-block function.....	66
1.26 Boiler start up (ignition).....	33	3.14	three-way anti-block function.....	66
1.27 DHW mixing valve.....	33	3.15	Radiators antifreeze function.....	66
1.28 Circulation pump.....	34	3.16	P.C.B. periodic self-check.....	66
1.29 Solar circuit circulation pump.....	36	3.17	Automatic vent function.....	66
1.30 Auto solar circulation pump with new wave 3 electronics.....	38	3.18	Casing removal.....	67
1.31 Main circulation unit components.....	39	4	Technical data.....	72
1.31 Domestic hot water storage tank unit.....	40	4.1	Variable heat output.....	72
1.32 Kits available on request.....	41	4.2	Combustion parameters.....	72
1.33 Boiler components.....	42	4.3	Technical data.....	73
		4.4	Key for Data nameplate.....	75
		4.5	Technical parameters for mixed boilers (in compliance with Regulation 813/2013).....	76
		4.6	Product fiche (in compliance with Regulation 811/2013).....	77
		4.7	Parameters for filling in the package fiche.....	78

## Dear Customer.

Our compliments for having chosen a top-quality Immergas product, able to ensure well-being and safety for a long period of time. As an Immergas customer you can also count on a Qualified Authorised After-Sales Technical Assistance Centre, prepared and updated to guarantee constant efficiency of your boiler. Read the following pages carefully: you will be able to draw useful tips on the correct use of the device, compliance of which will confirm your satisfaction with the Immergas product.

For assistance and routine maintenance, contact Authorised Technical Service Centres: they have original spare parts and are specifically trained directly by the manufacturer.

### GENERAL RECOMMENDATIONS

This book contains important information for the:

**Installer** (section 1);

**User** (section 2);

**Maintenance Technician** (section 3).



- The user must carefully read the instructions in the specific section (section 2).
- The user must limit operations on the appliance only to those explicitly allowed in the specific section.
- The appliance must be installed by qualified and professionally trained personnel.
- The instruction booklet is an integral and essential part of the product and must be given to the new user in the case of transfer or succession of ownership.
- It must be stored with care and consulted carefully, as all of the warnings provide important safety indications for installation, use and maintenance stages.
- In compliance with the legislation in force, the systems must be designed by qualified professionals, within the dimensional limits established by the Law. Installation and maintenance must be performed in compliance with the regulations in force, according to the manufacturer's instructions and by professionally qualified staff, meaning staff with specific technical skills in the plant sector, as provided for by Law.
- Improper installation or assembly of the Immergas device and/or components, accessories, kits and devices can cause unexpected problems for people, animals and objects. Read the instructions provided with the product carefully to ensure proper installation.
- This instructions manual provides technical information for installing Immergas products. As for the other issues related to the installation of products (e.g. safety at the workplace, environmental protection, accident prevention), it is necessary to comply with the provisions of the standards in force and the principles of good practice.
- All Immergas products are protected with suitable transport packaging.
- The material must be stored in a dry place protected from the weather.
- Damaged products must not be installed.
- Maintenance must be carried out by skilled technical staff. For example, the Authorised Immergas Service Centre that represents a guarantee of qualifications and professionalism.
- The device must only be destined for the use for which it has been expressly declared. Any other use will be considered improper and therefore potentially dangerous.
- If errors occur during installation, operation and maintenance, due to non-compliance with technical laws in force, standards or instructions contained in this booklet (or however supplied by the manufacturer), the manufacturer is excluded from any contractual and extra-contractual liability for any damages and the device warranty is invalidated.

The company **IMMERGAS S.p.A.**, with registered office in via Cisa Ligure 95 42041 Brescello (RE), declares that the design, manufacturing and after-sales assistance processes comply with the requirements of standard **UNI EN ISO 9001:2015**.

For further details on the product CE marking, request a copy of the Declaration of Conformity from the manufacturer, specifying the appliance model and the language of the country.

The manufacturer declines all liability due to printing or transcription errors, reserving the right to make any modifications to its technical and commercial documents without forewarning.



## SAFETY SYMBOLS USED.



### GENERIC HAZARD

Strictly follow all of the indications next to the pictogram. Failure to follow the indications can generate hazard situations resulting in possible harm to the health of the operator and user in general.



### ELECTRICAL HAZARD

Strictly follow all of the indications next to the pictogram. The symbol indicates the appliance's electrical components or, in this manual, identifies actions that can cause an electrical hazard.



### MOVING PARTS

The symbol indicates the appliance's moving components that can cause hazards.



### HOT SURFACES

The symbol indicates the appliance's very hot components that can cause burns.



### SHARP SURFACES

The symbol indicates the appliance's components or parts that can cause cuts if touched.



### EARTH TERMINAL CONNECTION

The symbol identifies the appliance's earth terminal connection point.

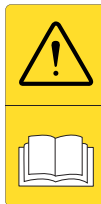

### READ AND UNDERSTAND THE INSTRUCTIONS

Read and understand the appliance's instructions before performing any operation, carefully following the indications provided.



### INFORMATION

Indicates useful tips or additional information.



**The user must not dispose of the appliance at the end of its service life as municipal waste, but send it to appropriate collection centres.**

## PERSONAL PROTECTIVE EQUIPMENT.



### SAFETY GLOVES



### SAFETY GOGGLES



### SAFETY FOOTWEAR

# 1 BOILER INSTALLATION.

## 1.1 INSTALLATION RECOMMENDATIONS.

### ATTENTION:

operators who install and service the appliance must wear the personal protective equipment required by applicable law.



The Hercules Solar 26 2 ErP boiler has been designed for wall mounted installation only; for central heating and production of domestic hot water for domestic use and similar purposes.

In the event the unit is installed in damp places, one must provide an insulation system underneath it, to insulate it from the ground.

The place of installation of the appliance and relative Immergas accessories must have suitable features (technical and structural), such as to allow for (always in safe, efficient and comfortable conditions):

- installation (according to the provisions of technical legislation and technical regulations);
- maintenance operations (including scheduled, periodic, routine, special);
- removal (to outdoors in the place for loading and transporting the appliances and components) as well as the eventual replacement of those with appliances and/or equivalent components.

By varying the type of installation the classification of the boiler also varies, precisely:

- Type B<sub>23</sub> or B<sub>53</sub> boiler if installed using the relevant terminal for air intake directly from the room in which the boiler has been installed.
- Type C boiler if installed using concentric pipes or other types of pipes envisioned for the sealed chamber boiler for intake of air and expulsion of flue gas.

Only professionally enabled companies are authorised to install Immergas gas appliances.

Installation must be carried out according to regulation standards, current legislation and in compliance with local technical regulations and the required technical procedures.



### ATTENTION:

It is not permitted to install boilers that are removed and decommissioned from other systems. The manufacturer declines all liability for damages caused by boilers removed from other systems or for any non-conformities of such equipment.



### ATTENTION:

check the environmental operating conditions of all parts relevant to installation, referring to the values shown in the technical data table in this booklet.



### ATTENTION:

Installation of the Hercules Solar 26 2 ErP boiler when powered by LPG must comply with the rules regarding gases with a greater density than air (remember, as an example, that it is prohibited to install plants powered with the above-mentioned gas in rooms where the floor is at a lower quota than the country level).



### ATTENTION:

if installing a kit or servicing the appliance, always empty the system's domestic hot water circuit first so as not to compromise the appliance's electrical safety (Par. 2.11 and 2.12).



Before installing the appliance, ensure that it is delivered in perfect condition; if in doubt, contact the supplier immediately. Packing materials (staples, nails, plastic bags, polystyrene foam, etc.) constitute a hazard and must be kept out of the reach of children.



If the appliance is installed inside or between cabinets, ensure sufficient space for normal servicing; for the minimum installation distances refer to Fig. 2.

It is just as important that the intake grids and exhaust terminals are not obstructed.

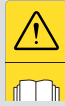

It is recommended to check that no flue gas recirculation is found in the air sample points (0.5% maximum permitted CO<sub>2</sub>).

Keep all flammable objects away from the appliance (paper, rags, plastic, polystyrene, etc.).

The minimum distance for exhaust pipes from flammable materials must be at least 25 cm.

For the aforementioned reasons, we recommend not placing furnishings, furniture, etc. under the boiler.

In the event of malfunctions, faults or incorrect operation, turn the appliance off immediately and contact an authorised company (e.g. the Authorised Technical Assistance centre, which has specifically trained staff and original spare parts). Do not attempt to modify or repair the appliance alone.

Any modification to the appliance that is not explicitly indicated in this section of the booklet is forbidden.

### Installation Standards:



**- this boiler must be installed in rooms where the temperature cannot fall below 0°C and must not be exposed to atmospheric agents.**

**- Installation of gas appliances, flue exhaust pipes and combustion air intake pipes is forbidden in places with a fire risk (for example: garages, closed parking stalls), and in potentially dangerous places.**

**- Installation is forbidden in places/rooms that constitute public areas of apartment buildings, internal stairways or other escape routes (e.g. floor landings, entrance halls, etc.).**

**- Installation is also forbidden in places/rooms that constitute public areas of apartment buildings such as cellars, entrance halls, attics, lofts, etc.. unless otherwise provided for by local regulations in force.**

These boilers are used to heat water to below boiling temperature in atmospheric pressure.



They must be connected to a central heating system and domestic hot water circuit suited to their performance and capacity.

### Risk of damage due to corrosion caused by unsuitable combustion air and environment.

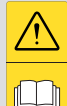

Spray, solvents, chlorine-based detergents, paints, glue., ammonium compounds, powders and similar cause product and flue duct corrosion.

- Check that combustion air power supply is free from chlorine, sulphur, powders, etc.

- Make sure that no chemical substances are stored in the place of installation.

- If you want to install the product in beauty salons, paint workshops, carpenter's shop, cleaning companies or similar, choose a separate installation area that ensures combustion air supply that is free from chemical substances.

- Make sure the combustion air is not fed from chimneys that were used with gas boilers or other heating devices. In fact, these may cause an accumulation of soot in the chimney.

### Risk of material damage after using sprays and liquids to search for leaks

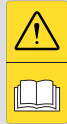

Leak sprays and liquids clog the reference hole PR. (Part. 4 Fig. 49) of the gas valve, damaging it irreparably.

During installation and maintenance, do not use spray or liquids in the upper area of the gas valve (side referring to the electric connections)

### Filling the condensate drain trap.



On first lighting of the boiler, flue gas may come out from the condensate drain; after a few minutes' operation, check that this no longer occurs. This means that the drain trap is filled with condensate to the correct level preventing the passage of flue gas.

### "Anti-legionella" heat treatment of the Immergas storage tank (activated by the specific function present on the predisposed thermoregulatory systems):



during this stage, the temperature of the water inside the storage tank exceeds 60°C with a relative risk of burns. Keep this domestic water treatment under control (and inform the users) to prevent unforeseeable damage to people, animals, things. If required install a thermostatic valve on the domestic hot water outlet to prevent scalding.

**ATTENTION:**

before starting the solar system. the solar collector must be covered to protect the absorber from overheating and the operator from scalding. The solar circuit must only be filled when the hydraulic system has been completely assembled and cannot be started before it has been possible to eliminate the heat generated by the solar collector.



To size the solar system, contact a qualified heating engineer.

**ATTENTION:**

- Type B open chamber boilers must not be installed in places where commercial, artisan or industrial activities take place, which use products that may develop volatile vapours or substances (e.g. acid vapours, glues, paints, solvents, combustibles, etc.). as well as dusts (e.g. dust deriving from the working of wood, coal fines, cement, etc.). which may be damaging for the components of the appliance and jeopardise functioning.
- Unless otherwise provided for by local regulations in force, configurations B<sub>23</sub> and B<sub>53</sub>: the boilers must not be installed in bedrooms, bathrooms or bedsits. They must neither be installed in rooms containing solid fuel heat generators nor in rooms communicating with said rooms.
- Installation of appliances in B<sub>23</sub> and B<sub>53</sub> configuration is recommended in non-residential premises and which are permanently ventilated.

**ATTENTION:**

Failure to comply with the above implies personal responsibility and invalidates the warranty.





## 1.2 MAIN DIMENSIONS.

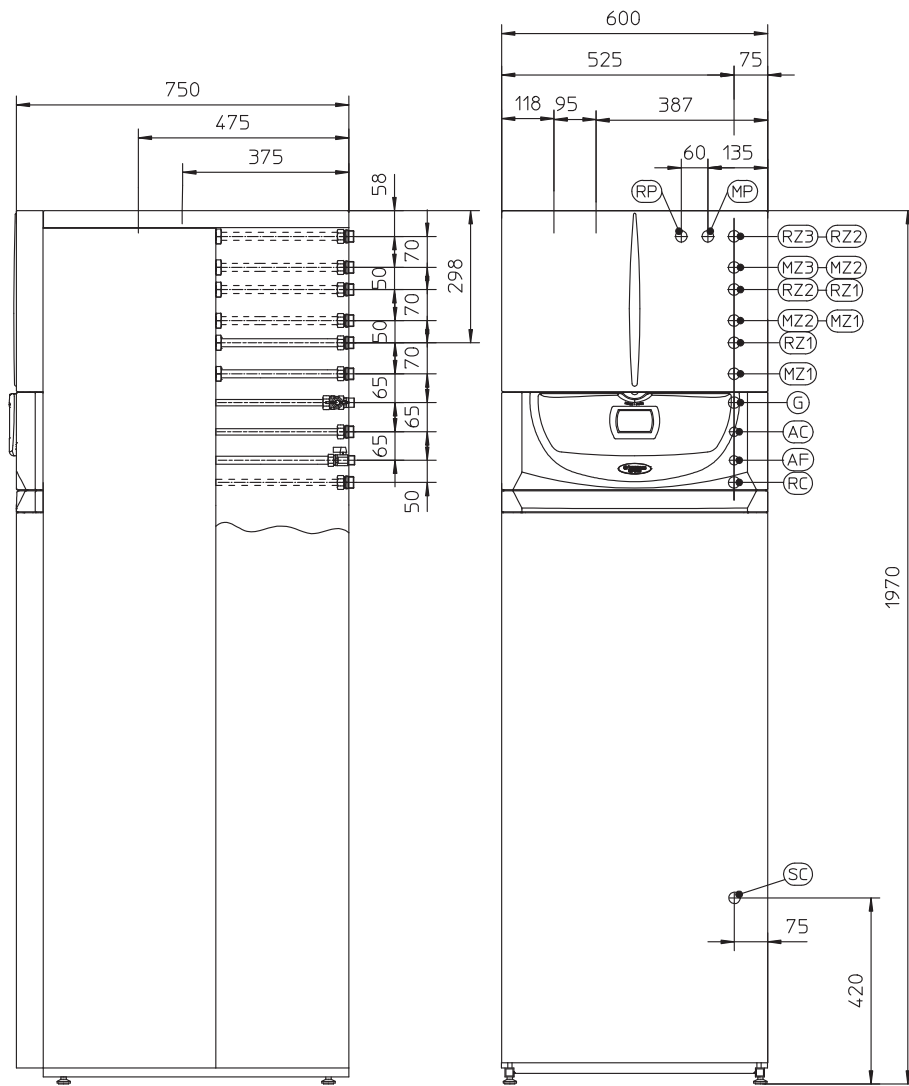

### Key:

- RZ3 - Direct zone 3 system return G 3/4" (optional)
- MZ3 - Direct zone 3 system flow G 3/4" (optional)
- RZ2 - Direct zone 2 system return G 3/4" (optional)
- MZ2 - Direct zone 2 system flow G 3/4" (optional)
- RZ2 - Mixed zone 2 system return G 1" (optional)
- MZ2 - Mixed zone 2 system flow G 1" (optional)
- RZ1 - Mixed zone 1 system return G 1" (optional)
- MZ1 - Mixed zone 1 system flow G 1" (optional)
- RZ1 - Direct zone 1 system return G 3/4"
- MZ1 - Direct zone 1 system flow G 3/4"
- G - Gas supply G 1/2"
- AC - DHW output G 3/4"
- AF - DHW inlet G 3/4"
- RP - Return to solar panels G 3/4"
- MP - Flow from solar panels G 3/4"
- RC - Recirculation G 3/4"
- SC - Condensate drain (minimum internal diameter  $\varnothing$  13 mm)

INSTALLER

USER

MAINTENANCE TECHNICIAN

1.3 MINIMUM INSTALLATION DISTANCES.

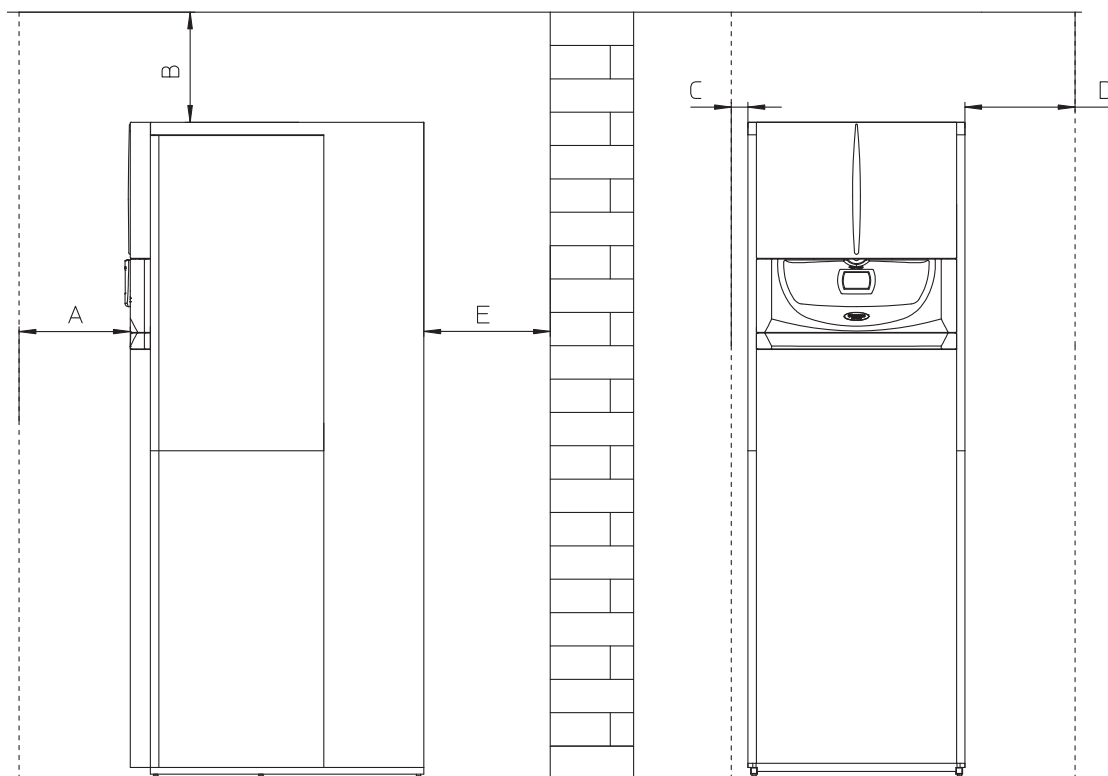

- Key:
- A - 450 mm
  - B - 350 mm
  - C - 30 mm
  - D - 400 mm
  - E - 10 mm

#### 1.4 GAS CONNECTION.

Our boilers are designed to operate with methane gas (G20) and LPG. Supply pipes must be the same as or larger than the boiler fitting.

##### **ATTENTION:**

**Before connecting the gas line, carefully clean inside all the fuel feed system pipes to remove any residue that could impair boiler efficiency. Also make sure the gas corresponds to that for which the boiler is prepared (see boiler data nameplate). If different, the boiler must be converted for operation with the other type of gas (see converting appliance for other gas types). It is also important to check the dynamic pressure of the mains (methane or LPG) used to supply the boiler, which must comply with EN 437 and its attachment, as insufficient levels may reduce generator output and cause discomfort to the user.**



**According to local regulations in force, make sure that a gas cock is installed upstream of each connection between the appliance and the gas system.**

**In any case, make sure the gas cock is connected properly.**



The gas supply pipe must be suitably dimensioned according to current regulations in order to guarantee correct gas flow rate to the burner even in conditions of maximum generator output and to guarantee appliance efficiency (technical specifications). The coupling system must conform to standards in force.

##### **ATTENTION:**

**the appliance is designed to operate with fuel gas free from impurities; otherwise it is advisable to fit special filters upstream of the appliance to restore the purity of the fuel.**



##### **Storage tanks (in case of supply from LPG depot).**

- New LPG storage tanks may contain residual inert gases (nitrogen) that degrade the mixture delivered to the appliance causing functioning anomalies.
- Due to the composition of the LPG mixture, layering of the mixture components may occur during the period of storage in the tanks. This can cause a variation in the calorific value of the mixture delivered to the appliance, with subsequent change in its performance.

## 1.5 HYDRAULIC CONNECTION.

In order not to void the condensation module warranty before making the boiler connections, carefully clean the heating system (pipes, radiators, etc.) with special pickling or descaling products to remove any deposits that could compromise correct boiler operation.



A treatment of the heating and water system water is required, in compliance with the technical standards in force, in order to protect the system and the appliance from deposits (e.g. scale), slurry or other hazardous deposits.

Water connections must be made in a rational way using the couplings on the boiler template.

### 3 - 8 bar safety valve.

The boiler safety valves outlet must be connected to a draining funnel. Otherwise, the manufacturer declines any responsibility in case of flooding if the drain valve cuts in.

### ATTENTION:

**the manufacturer declines all liability in the event of damage caused by the installation of an automatic filling system.**



In order to meet the system requirements established by EN 1717 in terms of pollution of drinking water, we recommend installing the IMMERGAS anti-backflow kit to be used upstream of the cold water inlet connection of the boiler. We also recommend using category 2 heat transfer fluid (ex: water + glycol) in the internal unit primary circuit (heating and/or cooling circuit), as defined in standard EN 1717.

To preserve the duration of appliance efficiency features, in the presence of water whose features can lead to the deposit of lime scale, installation of the “polyphosphate dispenser” kit is recommended.



## 1.6 SOLAR CIRCUIT HYDRAULIC CONNECTION.

### ATTENTION:

**when installing the solar circuit (pipes and fittings), only use suitable materials that withstand high temperatures.**



The pump unit allows you to connect the storage tank to the solar collector, making the water circulate according to the request of the control unit.

The pipes for connection to the solar collector must be ordered separately.



- Every time the solar system is emptied, the system must be rinsed well with running water.
- The circulation unit is not designed for use in direct contact with swimming pool water.

### Condensate drain.

To drain the condensate produced by the appliance, it is necessary to connect to the drainage system by means of acid condensate resistant pipes, with an internal Ø of at least 13 mm. The system connecting the appliance to the drainage system must be carried out in such a way as to prevent occlusion and freezing of the liquid contained in it. Before appliance ignition, ensure that the condensate can be correctly removed. After first ignition, check that the drain trap is filled with condensate (Para. 1.22). Also, comply with national and local regulations on discharging waste waters.

In the event condensate is not discharged into the wastewater drainage system, a condensate neutraliser must be installed to ensure compliance with the parameters established by the legislation in force.

## 1.7 ELECTRICAL CONNECTION.

The appliance has an IPX5D protection degree; electrical safety of the appliance is achieved only when it is connected properly to an efficient earthing system, as specified by current safety standards.

### ATTENTION:

**the manufacturer declines any responsibility for damage or physical injury caused by failure to connect the boiler to an efficient earthing system or failure to comply with the reference standards.**



Also ensure that the electrical installation corresponds to maximum absorbed power specifications as shown on the boiler data nameplate. The boilers are supplied complete with a “X” type power cable without plug.

### ATTENTION:

**The power supply cable must be connected to a 230V  $\pm 10\%$  / 50Hz mains supply respecting L-N polarity and earth connection;  this network must also have a multi-pole circuit breaker with class III overvoltage category in compliance with installation regulations.**



To protect from possible dispersions of DC voltage, it is necessary to provide a type A differential safety device.

If the power supply cable is damaged, it must be replaced by a special cable or assembly, which are only available from the manufacturer or its Authorised After-Sales Technical Assistance Centre. It is recommended to contact a qualified company (e.g. the Authorised After-Sales Technical Assistance Centre) for replacement to avoid a hazard.

The power cable must be laid as shown (Fig. 4).

If the network fuse on the integrated P.C.B. needs replacing, this must also be done by qualified personnel: use a 3.15 A F (fast) 250 V fuse (size 5 x 20).

For the main power supply to the appliance, never use adapters, multiple sockets or extension leads.

**Solar panels electrical connection.** Only use an appropriately sized cable to make the connections. Making them follow the same route as the power supply cable (in the relevant pipe), make the connections on the control panel on clamps 45 and 46, eliminating the resistance R15 (Fig. 3). Connect the supplied probe on the solar panel and position it in the relevant seat.

### Installation with system operating at direct low temperature.

The boiler can directly feed a low temperature system by acting on parameter “P66” (Par. 3.11) and setting the delivery temperature adjustment range “P66/A” and “P66/B”. In this situation it is good practice to insert a safety device in series with the power supply and boiler. This device is made up from a thermostat with a temperature limit of 60°C. The thermostat must be positioned on the system flow pipe at a distance of at least 2 metres from the boiler.

INSTALLER

USER

MAINTENANCE TECHNICIAN

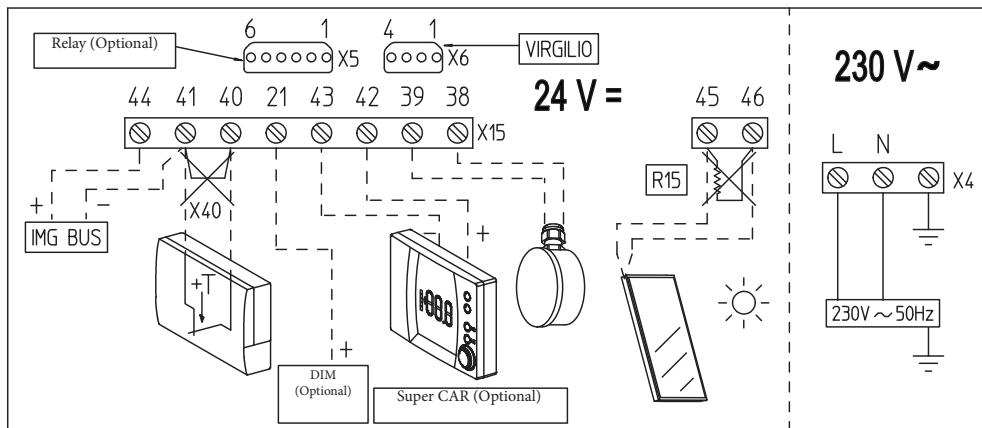

3

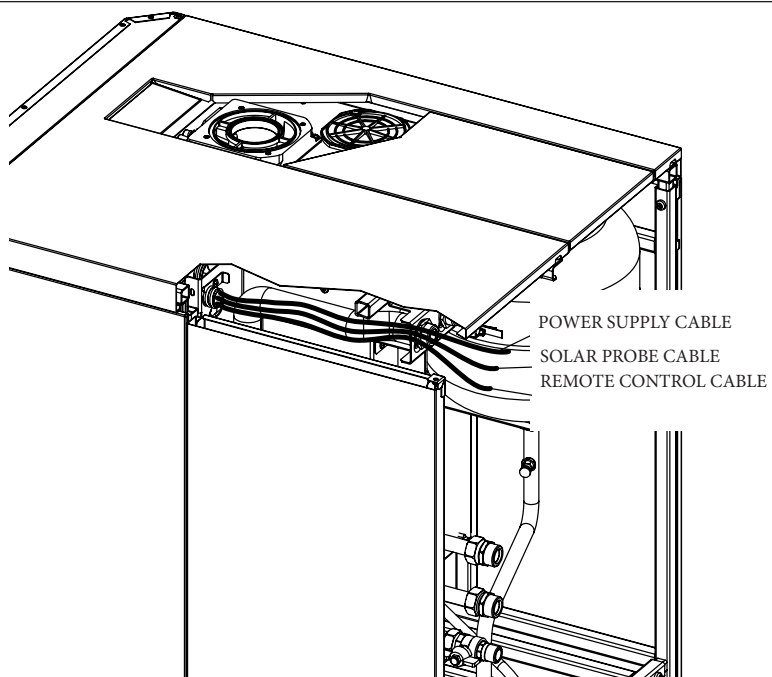

4

## 1.8 REMOTE CONTROLS AND ROOM CHRONO-THERMOSTATS (OPTIONAL).

The boiler is prepared for the application of room chrono-thermostats or remote controls, which are available as optional kits. All Immergas chrono-thermostats are connected with 2 wires only. Carefully read the user and assembly instructions contained in the accessory kit.

### ATTENTION:

**disconnect power to the appliance before any electrical connection.**



#### • On/Off Immergas digital chrono-thermostat (Fig. 5).

The chrono-thermostat allows:

- set two room temperature value: one for day (comfort temperature) and one for night (reduced temperature);
- set a weekly programme with four daily switch on and switch off times;
- selecting the required function mode from the various possible alternatives:
  - manual mode (with adjustable temperature).
  - automatic mode (with set programme).
  - forced automatic mode (momentarily changing the temperature of the automatic programme).

The chrono-thermostat is powered by two 1.5V LR 6 type alkaline batteries;

#### • Comando Amico Remoto remote control<sup>V2</sup> (CAR<sup>V2</sup>) and Super Comando Amico Remoto remote control (Super CAR) both with a climate chrono-thermostat operation (Fig. 6).

In addition to the functions described in the previous point, the chrono-thermostat panels enable the user to control all the important information regarding operation of the appliance and the central heating system with the opportunity of easily intervening on the previously set parameters without having to go to the place where the appliance is installed. The panel is provided with self-diagnosis to display any boiler functioning anomalies. The climate chrono-thermostat incorporated into the remote panel enables the system flow temperature to be adjusted to the actual needs of the room being heated, in order to obtain the desired room temperature with extreme precision and therefore with evident saving in running costs. The chrono-thermostat is fed directly by the boiler by means of the same 2 wires used for transmitting data between boiler and device.

If the system is divided into zones using the relevant kit, the CAR<sup>V2</sup> must be used with its climate thermostat function disabled, i.e. it must be set to On/Off mode.



CAR<sup>V2</sup>, Super CAR or On/Off chrono-thermostat electrical connection (Optional). *The operations described below must be performed after having removed the voltage from the appliance.* Any On/Off room chrono-thermostat must be connected to clamps 40 and 41 eliminating jumper X40 (Fig. 48). Make sure that the On/Off thermostat contact is of the “clean” type, i.e. independent of the mains voltage, otherwise the P.C.B. would be damaged. Any CAR<sup>V2</sup> or Super CAR must be connected by means of terminals IN+ and IN- to terminals 42 and 43 on the P.C.B. (in the boiler), eliminating jumper X40 and respecting polarity (Fig. 48). Connection with the wrong polarity prevents functioning, but without damaging the CAR<sup>V2</sup>. The boiler can only be connected to one remote control.

If the Comando Amico Remoto remote control<sup>V2</sup> or any other On/Off chrono-thermostat is used arrange two separate lines in compliance with current regulations regarding electrical systems. No boiler pipes must ever be used to earth the electric system or telephone lines. Ensure elimination of this risk before making the boiler electrical connections.

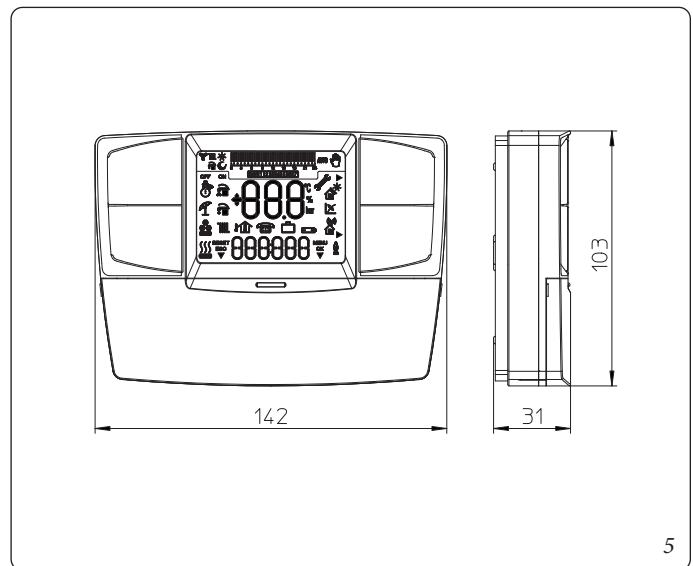

5

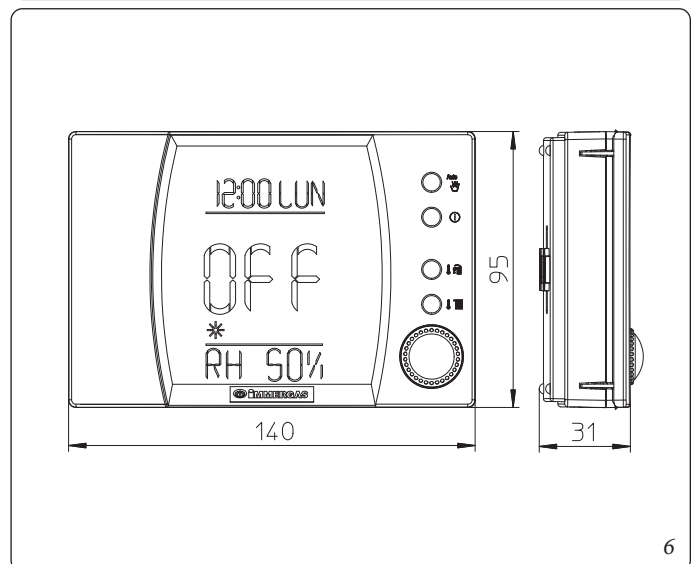

6

INSTALLER

USER

MAINTENANCE TECHNICIAN

**1.9 EXTERNAL TEMPERATURE PROBE (OPTIONAL).**

The boiler is designed for the application of the external temperature probe (Fig. 7), which is available as an optional kit. Refer to the relative instruction sheet to position the external probe. The probe can be connected directly to the boiler electrical system and allows the max. system flow temperature to be automatically decreased when the external temperature increases, in order to adjust the heat supplied to the system according to the change in external temperature. The external probe always operates when connected, regardless of the presence or type of room chrono-thermostat used and can work in combination with Immergas timer thermostats. The correlation between system flow temperature and external temperature is determined by the parameters set in menu “M5” under item “P66” according to the curves represented in the diagram (Fig. 8). The electric connection of the external probe must be made on clamps 38 and 39 on the boiler P.C.B. (Fig. 48).

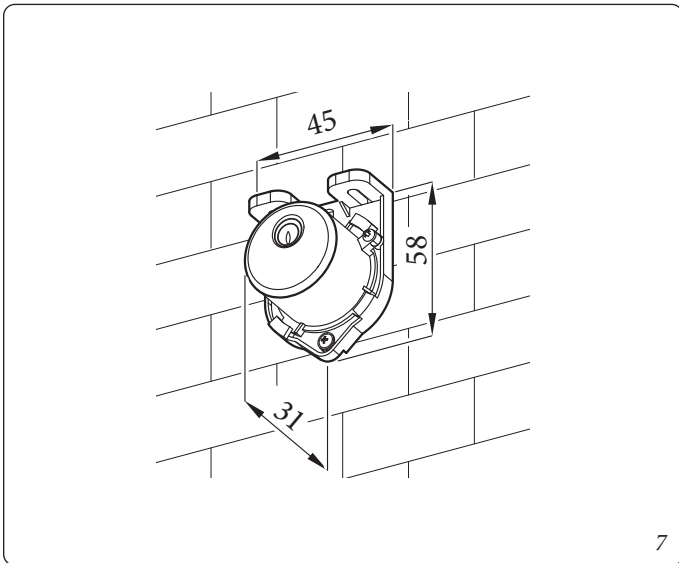

7

**EXTERNAL PROBE**

*Correction law of the flow temperature depending on the external temperature and user adjustment of the central heating temperature.*

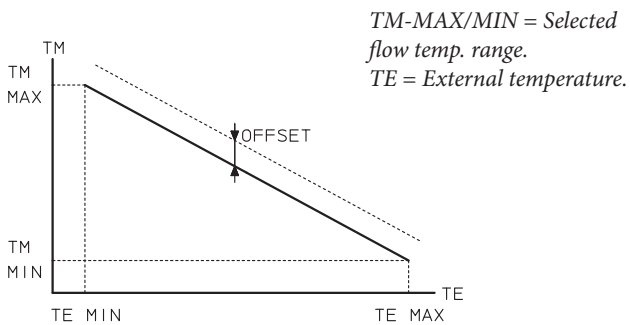

8



## 1.10 IMMERGAS FLUE SYSTEMS.

Immergas supplies various solutions separately from the boilers regarding the installation of air intake terminals and flue exhaust, which are fundamental for boiler operation.

### ATTENTION:



**the boiler must be installed exclusively with an original Immergas “Green Range” inspectionable air intake system and flue gas extraction system made of plastic, with the exception of the C6 configuration, as required by the regulations in force and by the product’s approval.**

**This flue can be identified by an identification mark and special distinctive marking bearing the note "only for condensation boilers".**

**The plastic pipes cannot be installed outdoors, for tracts longer than 40 cm, without suitable protection from UV rays and other atmospheric agents.**

#### • Resistance factors and equivalent lengths.

Each flue component has a *Resistance Factor* based on experimental tests and specified in the table below. The Resistance Factor for individual components is independent from the type of boiler on which it is installed and has a dimensionless size. It is however, conditioned by the temperature of the fluids that pass through the pipe and therefore, varies according to applications for air intake or flue exhaust. Each single component has a resistance corresponding to a certain length in metres of pipe of the same diameter; the so-called *equivalent length*, can be obtained from the ratio between the relative Resistance Factors.

**All boilers have an experimentally obtainable maximum Resistance Factor equal to 100.**

The maximum Resistance Factor allowed corresponds to the resistance encountered with the maximum allowed pipe length for each type of Terminal Kit. This information allows calculations to be made to verify the possibility of setting up various flue configurations.

**Note:** to dimension the flue ducting using commercial components, refer to the table of combustion parameters (Paragraph 4.2).

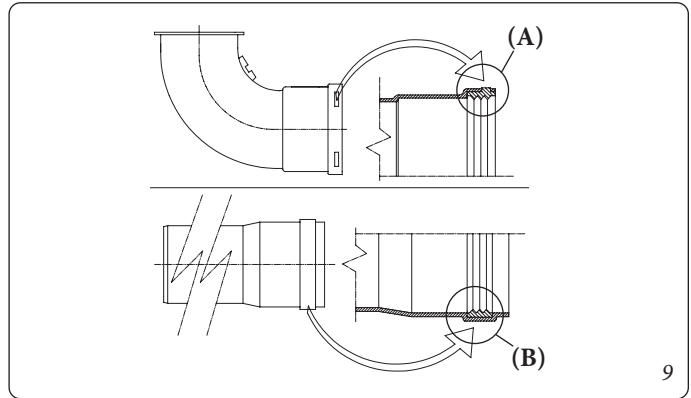

#### • Positioning the gaskets (black) for “green range” flue systems.

Position the gasket correctly (for bends and extensions) (Fig. 9):

- gasket (A) with notches, to use for bends;
- gasket (B) without notches, to use for extensions.

**N.B.:** if necessary, to ease the push-fitting, spread the elements with commonly-used talc.

#### • Extension pipes and concentric elbows push-fittings.

To install push-fitting extensions with other elements of the flue extraction elements assembly, proceed as follows: Install the concentric pipe or elbow with the male side (smooth) on the female side (with lip seal) to the end stop on the previously installed element in order to ensure sealing efficiency of the coupling.

**N.B.:** if the exhaust terminal and/or extension concentric pipe needs shortening, consider that the internal duct must always protrude by 5 mm with respect to the external duct.





**N.B.:** for safety purposes, do not obstruct the boiler intake/exhaust terminal, even temporarily.





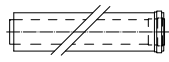

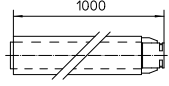
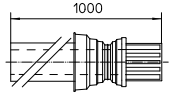



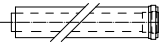

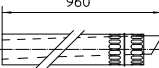

The various parts of the flue system must be checked to ensure that they have been laid in such a way as to prevent the coupled parts from detaching, in particular, the flue exhaust duct in the Ø80 separator kit configuration. Should the aforesaid condition not be adequately guaranteed, it will be necessary to use the special clamp ring nut clip kit.



**N.B.:** when installing horizontal pipes, a minimum inclination of 3% towards the boiler must be maintained, and a section clip with pin must be installed every 3 metres.

**1.11 TABLES OF RESISTANCE FACTORS AND EQUIVALENT LENGTHS.**

TYPE OF DUCT		Resistance Factor (R)	Equivalent length in metres of concentric pipe Ø 80/125
Concentric pipe 80/125 Ø m 1		2.1	1
90° concentric bend 80/125 Ø		3.0	1.4
Concentric bend 45° Ø 80/125		2.1	1
Terminal complete with concentric horizontal intake-exhaust Ø 80/125		2.8	1.3
Terminal complete with concentric vertical intake-exhaust Ø 80/125		3.6	1.7
90° concentric bend Ø 80/125 with inspection		3.4	1.6
Stub pipe with inspection Ø 80/125		3.4	1.6

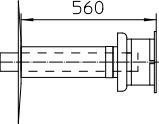
TYPE OF DUCT		Resistance Factor (R)	Equivalent length in metres of concentric pipe Ø 60/100	Equivalent length in metres of a Ø 80 pipe	Equivalent length in metres of a Ø 60 pipe	Equivalent length in metres of concentric pipe Ø 80/125
Concentric pipe Ø 60/100 m 1		Intake and Exhaust 6.4	<b>m 1</b>	Intake m 7.3	Exhaust m 1.9	m 3.0
				Exhaust m 5.3		
90° concentric bend Ø 60/100		Intake and Exhaust 8.2	<b>m 1.3</b>	Intake m 9.4	Exhaust m 2.5	m 3.9
				Exhaust m 6.8		
Concentric bend 45° Ø 60/100		Intake and Exhaust 6.4	<b>m 1</b>	Intake m 7.3	Exhaust m 1.9	m 3.0
				Exhaust m 5.3		
Terminal complete with concentric horizontal intake-exhaust Ø 60/100		Intake and Exhaust 15	<b>m 2.3</b>	Intake m 17.2	Exhaust m 4.5	m 7.1
				Exhaust m 12.5		
Concentric horizontal intake-exhaust terminal Ø 60/100		Intake and Exhaust 10	<b>m 1.5</b>	Intake m 11.5	Exhaust m 3.0	m 4.7
				Exhaust m 8.3		
Terminal complete with concentric vertical intake-exhaust Ø 60/100		Intake and Exhaust 16.3	<b>m 2.5</b>	Intake m 18.7	Exhaust m 4.9	m 7.7
				Exhaust m 13.6		
Concentric vertical intake-exhaust terminal Ø 60/100		Intake and Exhaust 9	<b>m 1.4</b>	Intake m 10.3	Exhaust m 2.7	m 4.3
				Exhaust m 7.5		
Pipe Ø 80 m 1		Intake 0.87	m 0.1	<b>Intake m 1.0</b>	Exhaust m 0.4	m 0.4
		Exhaust 1.2	m 0.2	<b>Exhaust m 1.0</b>		m 0.5
Complete intake terminal Ø 80 m 1		Intake 3	m 0.5	<b>Intake m 3.4</b>	Exhaust m 0.9	m 1.4
Intake terminal Ø 80 Exhaust terminal Ø 80		Intake 2.2	m 0.35	<b>Intake m 2.5</b>	Exhaust m 0.6	m 1
		Exhaust 1.9	m 0.3	<b>Exhaust m 1.6</b>		m 0.9
Bend 90° Ø 80		Intake 1.9	m 0.3	<b>Intake m 2.2</b>	Exhaust m 0.8	m 0.9
		Exhaust 2.6	m 0.4	<b>Exhaust m 2.1</b>		m 1.2
Bend 45° Ø 80		Intake 1.2	m 0.2	<b>Intake m 1.4</b>	Exhaust m 0.5	m 0.5
		Exhaust 1.6	m 0.25	<b>Exhaust m 1.3</b>		0.7
Pipe Ø 60 m 1 for ducting		Exhaust 3.3	m 0.5	Intake 3.8	<b>Exhaust m 1.0</b>	m 1.5
				Exhaust 2.7		
Bend 90° Ø 60 for ducting		Exhaust 3.5	m 0.55	Intake 4.0	<b>Exhaust m 1.1</b>	m 1.6
				Exhaust 2.9		
Reduction Ø 80/60		Intake and Exhaust 2.6	m 0.4	Intake m 3.0	<b>Exhaust m 0.8</b>	m 1.2
				Exhaust m 2.1		
Terminal complete with exhaust vertical Ø 60 for ducting		Exhaust 12.2	m 1.9	Intake m 14	<b>Exhaust m 3.7</b>	m 5.8
				Exhaust m 10.1		

INSTALLER

USER

MAINTENANCE TECHNICIAN

## 1.12 INSTALLATION OF BOILER TYPE B WITH OPEN CHAMBER AND FAN ASSISTED (OPTIONAL).

**Configuration type B, open chamber and fan assisted.**  
(B<sub>23</sub> or B<sub>53</sub>).

In this configuration the relevant terminal must be used (present in the intake kit for the installation in question) to be placed on the intake hole above the sealed chamber (Fig. 10). Air intake takes place directly from the environment and flue exhaust in individual chimney or to the outside. The boiler in this configuration, following the assembly instructions stated on the relative instruction sheet, is classified as type B<sub>23</sub> or B<sub>53</sub> (according to the applicable regulations).

With this configuration:

air intake takes place directly from the environment in which the boiler is installed and only functions in permanently ventilated rooms

- the flue gas exhaust must be connected to its own individual flue or ducted directly into the external atmosphere;
- Type B open chamber boilers must not be installed in places where commercial, artisan or industrial activities take place, which use products that may develop volatile vapours or substances (e.g. acid vapours, glues, paints, solvents, combustibles, etc.), as well as dusts (e.g. dust deriving from the processing of wood, coal dust, cement, etc.), which may be harmful for the components of the appliance and jeopardise operation;
- in B<sub>23</sub> and B<sub>53</sub> configuration, the boilers must not be installed in bedrooms, bathrooms or in studio flats;
- installation of appliances in B<sub>23</sub> or B<sub>53</sub> configuration is recommended in non-residential premises and which are permanently ventilated.

The following technical regulations in force must therefore be adhered to.

**Max. length of exhaust duct.** The flue pipe (both vertical or horizontal) can be extended to a max. length of 30 linear metres.

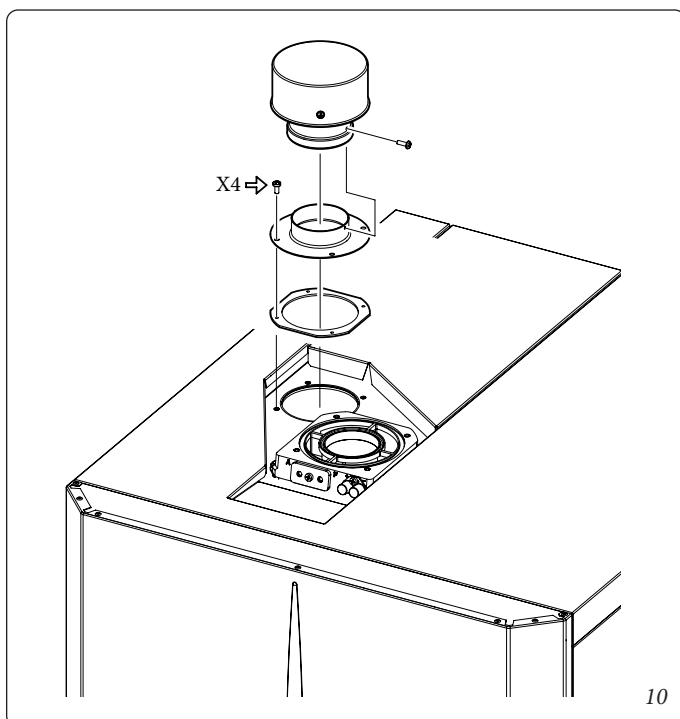

### 1.13 CONCENTRIC HORIZONTAL KIT INSTALLATION.

#### • Type C configuration. sealed chamber and fan assisted.

The installation of this terminal is governed by the applicable technical standards and subsequent amendments. that enables wall flue exhaust for condensing boilers with low NOx in the cases provided. The position of the terminal (in terms of distances from openings, overlooking buildings, floor, etc.) must be in compliance with the regulations in force.

This terminal is connected directly to the outside of the building for air intake and flue gas exhaust. The horizontal kit can be installed with the rear, right side, left side or front outlet. For installation with frontal outlet, one must use the fixing plate and a concentric bend coupling in order to ensure sufficient space to carry out the tests required by law upon commissioning.

#### • External grid.

Both the Ø 60/100 and Ø 80/125 intake/exhaust terminal. if properly installed, is pleasant to look at on the outside of the building. Make sure that the external silicone wall sealing plate is properly inserted in the wall.

#### ATTENTION:

**for correct functioning of the system the terminal with grid must be installed correctly ensuring that, the "high" indication present on the terminal is respected on installation.**



#### Horizontal intake-exhaust kit Ø 60/100. Kit Assembly.

(Fig. 11):

install the bend with flange (2) on the central hole of the boiler. positioning gasket (1) with the circular projections downwards in contact with the boiler flange, and tighten using the screws present in the kit. Fit the Ø 60/100 (3) concentric terminal pipe with the male side (smooth) to the female side of the bend (2) up to the end stop; making sure that the internal and external wall sealing plate have been fitted, this will ensure sealing and joining of the elements making up the kit.

#### • Extensions for Ø 60/100 horizontal kit (Fig. 12).

The kit with this configuration can be extended up to a max. horizontal length of 12.9 m including the terminal with grid and excluding the concentric bend leaving the boiler. This configuration corresponds to a resistance factor of 100. In this case the special extensions must be requested.

Immergas also provides a Ø 60/100 simplified terminal, which in combination with its extension kits allows you to reach a maximum extension of 11.9 metres.

#### Horizontal intake-exhaust kit Ø 80/125 Kit Assembly.

(Fig. 13):

to install the kit Ø 80/125 one must use the flanged adapter kit in order to install the flue system Ø 80/125. Install the flanged adaptor (2) on the central hole of the boiler, positioning gasket (1) with the circular projections downwards in contact with the boiler flange, and tighten using the screws contained in the kit. Engage the bend (3) with the male side (smooth) to the end stop on the adapter (1). Fit the Ø 80/125 (5) concentric terminal pipe with the male side (smooth) to the female side of the bend (4) (with lip seals) up to the end stop; making sure that the internal (6) and external wall sealing plate (7) have been fitted, this will ensure sealing and joining of the elements making up the kit.

#### • Extensions for Ø 80/125 horizontal kit (Fig. 14).

The kit with this configuration can be extended up to a max. length of 32 m, including the terminal with grid and excluding the concentric bend leaving the boiler. If additional components are assembled, the length equivalent to the maximum allowed must be subtracted, In this case the special extensions must be requested.

C<sub>13</sub>

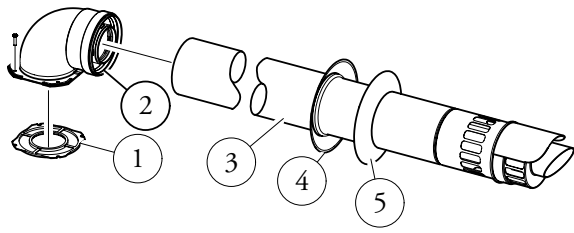

The kit includes:

- N° 1 - Gasket (1)
- N° 1 - Concentric bend Ø 60/100 (2)
- N° 1 - Int./exhaust concentric terminal Ø 60/100 (3)
- N° 1 - Internal wall sealing plate (4)
- N° 1 - External wall sealing plate (5)

11

C<sub>13</sub>

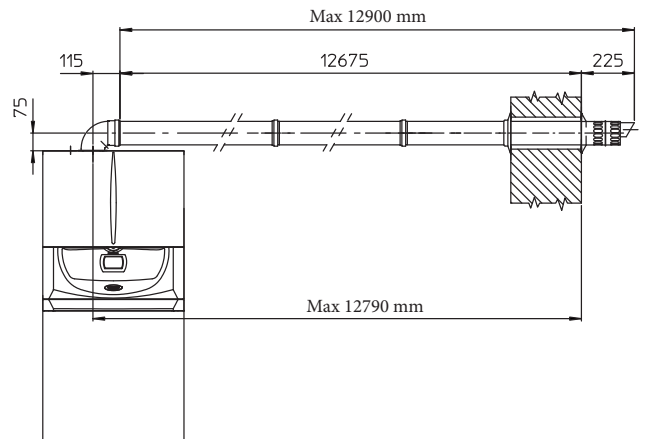

12

C<sub>13</sub>

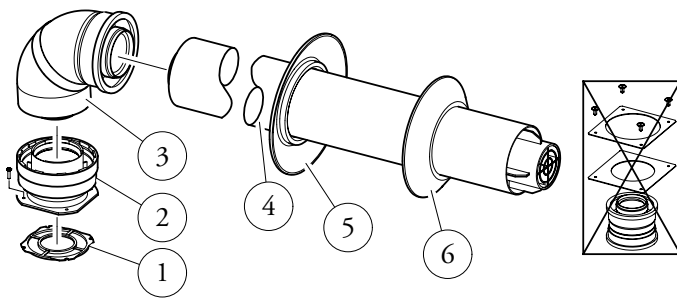

The adaptor kit includes:

- N° 1 - Gasket (1)
- N° 1 - Adaptor Ø 80/125 (2)

The Kit Ø 80/125 includes:

- N° 1 - Concentric bend Ø 80/125 a 87° (3)
  - N° 1 - Int./exhaust concentric terminal Ø 80/125 (4)
  - N° 1 - Internal wall sealing plate (5)
  - N° 1 - External wall sealing plate (6)
- The remaining kit components must not be used

13

C<sub>13</sub>

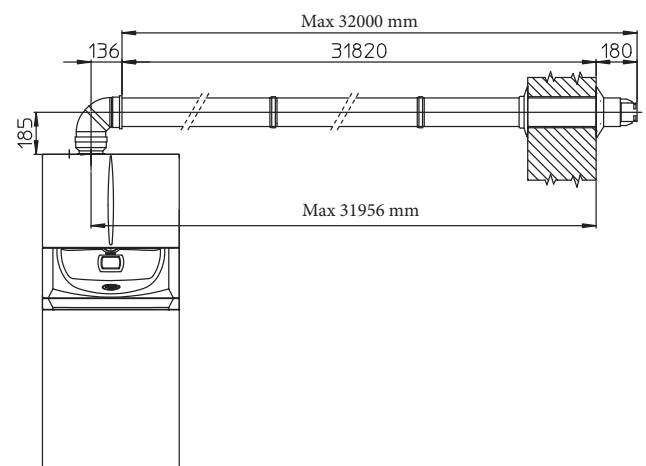

14

## 1.14 CONCENTRIC VERTICAL KIT INSTALLATION.

### • Type C configuration, sealed chamber and fan assisted.

Concentric vertical intake and exhaust kit. This vertical terminal is connected directly to the outside of the building for air intake and flue gas exhaust.

**N.B.:** the vertical kit with aluminium tile enables installation on terraces and roofs with a maximum slope of 45% (approx 25°) and the height between the terminal cap and half-shell (374 mm for Ø 60/100 and 260 mm for Ø 80/125) must always be observed.

### Vertical kit with aluminium tile Ø 60/100.

#### Kit assembly (Fig. 15):

install the concentric flange (2) on the central hole of the boiler, positioning gasket (1) with the circular projections downwards in contact with the boiler flange, and tighten using the screws contained in the kit.

Installation of the fake aluminium tile: replace the tiles with the aluminium sheet (4), shaping it to ensure that rainwater runs off. Position the fixed half-shell (6) on the aluminium tile and insert the intake-exhaust pipe (5). Fit the Ø 60/100 concentric terminal pipe with the male side (5) (smooth) into the flange (2) up to the end stop; making sure that the wall sealing plate has been fitted (3), this will ensure sealing and joining of the elements making up the kit.

**NOTE:** when the boiler is installed in areas where very cold temperatures can be reached, a special anti-freeze kit is available that can be installed as an alternative to the standard kit.

### • Extensions for vertical kit Ø 60/100 (Fig. 16).

The kit with this configuration can be extended to a max. straight vertical length of 14.4 m, including the terminal. This configuration corresponds to a resistance factor of 100. In this case specific extensions must be requested.

### Vertical kit with aluminium tile Ø 80/125.

#### Kit assembly (Fig. 17):

to install the kit Ø 80/125 one must use the flanged adaptor kit in order to install the flue system Ø 80/125. Install the flanged adaptor (2) on the central hole of the boiler, positioning gasket (1) with the circular projections downwards in contact with the boiler flange, and tighten using the screws contained in the kit. Installation of the fake aluminium tile: replace the tiles with the aluminium sheet (4), shaping it to ensure that rainwater runs off. Position the fixed half-shell (5) on the aluminium tile and insert the intake-exhaust pipe (7). Fit the Ø 80/125 concentric terminal pipe with the male side (smooth) to the female side of the adapter (1) (with lip gaskets) up to the end stop; making sure that the wall sealing plate (3) has been fitted, this will ensure sealing and joining of the elements making up the kit.

### • Extensions for vertical kit Ø 80/125 (Fig. 18).

The kit with this configuration can be extended up to a max. length of 32 m including the terminal. If additional components are assembled, the length equivalent to the maximum allowed must be subtracted. In this case specific extensions must be requested.

C<sub>33</sub>

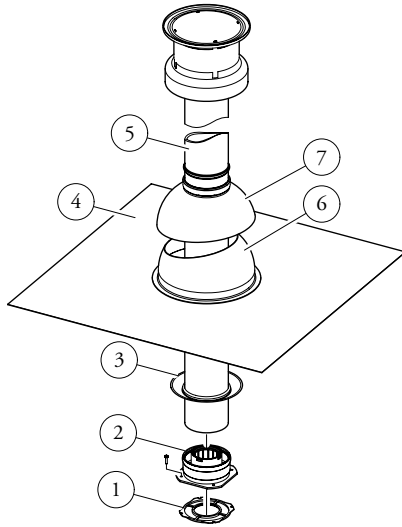

The Kit includes:

- N° 1 - Gasket (1)
- N° 1 - Female concentric flange (2)
- N° 1 - Wall sealing plate (3)
- N° 1 - Aluminium tile (4)
- N° 1 - Int./exhaust concentric pipe Ø 60/100 (5)
- N° 1 - Fixed half-shell (6)
- N° 1 - Mobile half-shell (7)

15

C<sub>33</sub>

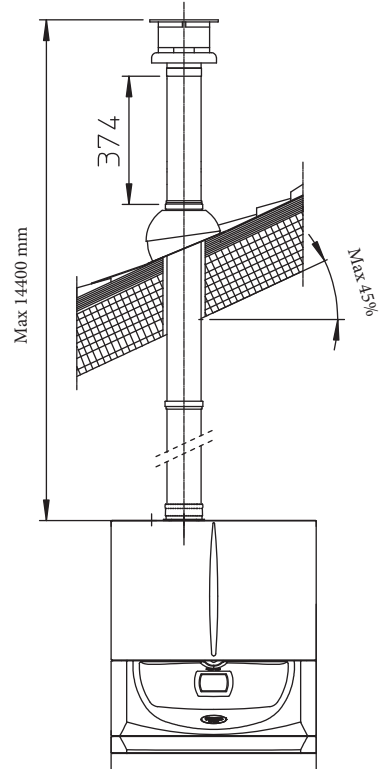

16

C<sub>33</sub>

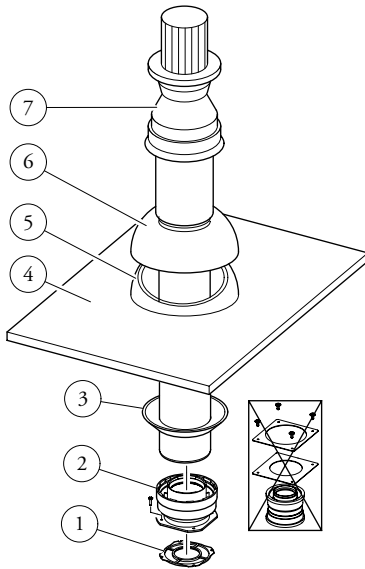

The adaptor kit includes:

- N° 1 - Gasket (1)
- N° 1 - Adaptor Ø 80/125 (2)

The Kit Ø 80/125 includes:

- N° 1 - Wall sealing plate (3)
  - N° 1 - Aluminium tile (4)
  - N° 1 - Fixed half-shell (5)
  - N° 1 - Mobile half-shell (6)
  - N° 1 - Int./exhaust concentric pipe Ø 80/125 (7)
- The remaining kit components must not be used

17

C<sub>33</sub>

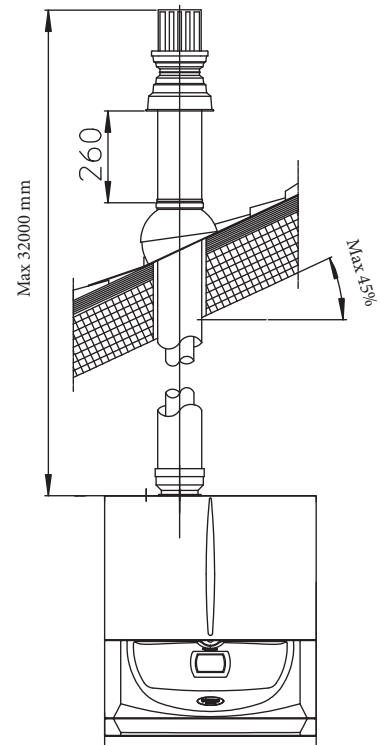

18



## 1.15 SEPARATOR KIT INSTALLATION.

### Type C configuration, sealed chamber and fan assisted.

- **Separator kit Ø 80/80.**

This kit allows air to come in from outside the building and the exhaust to exit from the chimney, flue or intubated duct through divided flue exhaust and air intake pipes. Combustion products are expelled from pipe (S) (in plastic, so as to resist acid condensate). Air is taken in through duct (A) for combustion (this is also in plastic). The intake pipe (A) can be installed either on the right or left hand side of the central exhaust pipe (S). Both ducts can be routed in any direction.

- **Kit assembly (Fig. 19):**

install flange (4) on the central hole of the boiler, positioning gasket (1) with the circular projections downwards in contact with the boiler flange, and tighten using the hex screws with flat tip contained in the kit. Remove the flat flange present in the lateral hole with respect to the central one (according to needs) and replace it with the flange (3), positioning the gasket (2) already present in the boiler and tighten using the supplied self-threading screws. Fit the male side (smooth) to the bends (5) in the female side of the flanges (3 and 4). Fit the intake terminal (6) with the male side (smooth) in the female side of the bend (5) up to the end stop, ensuring that the internal and external wall sealing plates are fitted. Fit the exhaust pipe (9) with the male end (smooth) to the female end of the bend (5) up to the end stop; making sure that the internal wall sealing plate has been fitted. this will ensure sealing and joining of the elements making up the kit.

- **Installation clearances (Fig. 20).**

The minimum installation clearance measurements of the Ø 80/80 separator terminal kit have been stated in some limit conditions.

- **Extensions for separator kit Ø 80/80.**

The maximum vertical straight length (without bends) that can be used for Ø 80 intake and exhaust pipes is 41 metres, regardless from whether they are used for intake or exhaust. The maximum horizontal straight length (with bend in suction and in exhaust) that can be used for Ø 80 intake and exhaust pipes is 36 metres, regardless from whether they are used for intake or exhaust. Please note the type of installation  $C_{43}$  must be done with a natural draught flue.

**N.B.:** to favour the removal of possible condensate forming in the exhaust pipe, tilt the pipes towards the boiler with a minimum slope of 1.5% (Fig. 21).

C<sub>53</sub>\* - C<sub>83</sub>

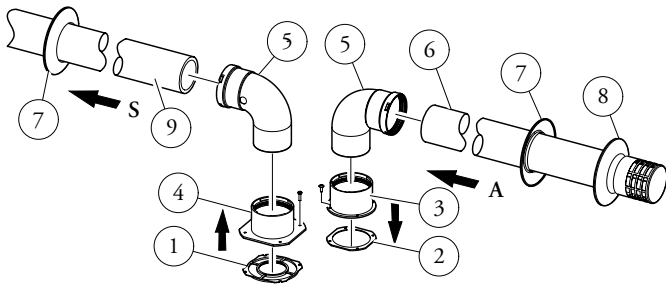

The kit includes:

- N° 1 - Exhaust gasket (1)
- N° 1 - Flange seal gasket (2)
- N° 1 - Female intake flange (3)
- N° 1 - Female drain flange (4)
- N° 2 - Bend 90° Ø 80 (5)
- N° 1 - Intake terminal Ø 80 (6)
- N° 2 - Internal wall sealing plates (7)
- N° 1 - External wall sealing plate (8)
- N° 1 - Drain pipe Ø 80 (9)

\* to er complete C<sub>53</sub> configuration also provide for a roof discharge terminal.

19

C<sub>43</sub>

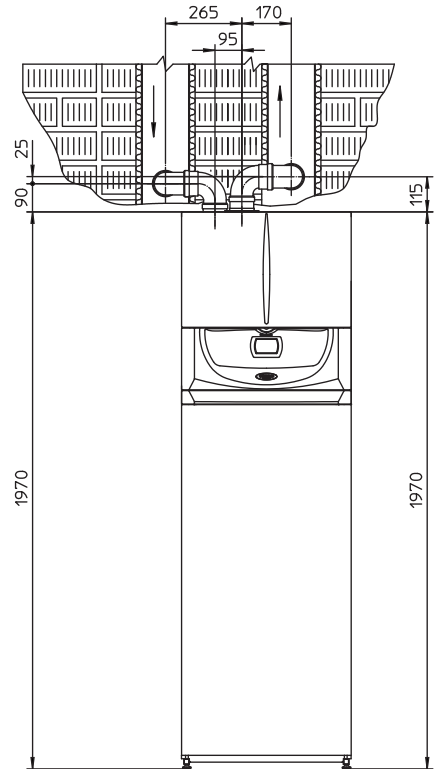

20

C<sub>83</sub>

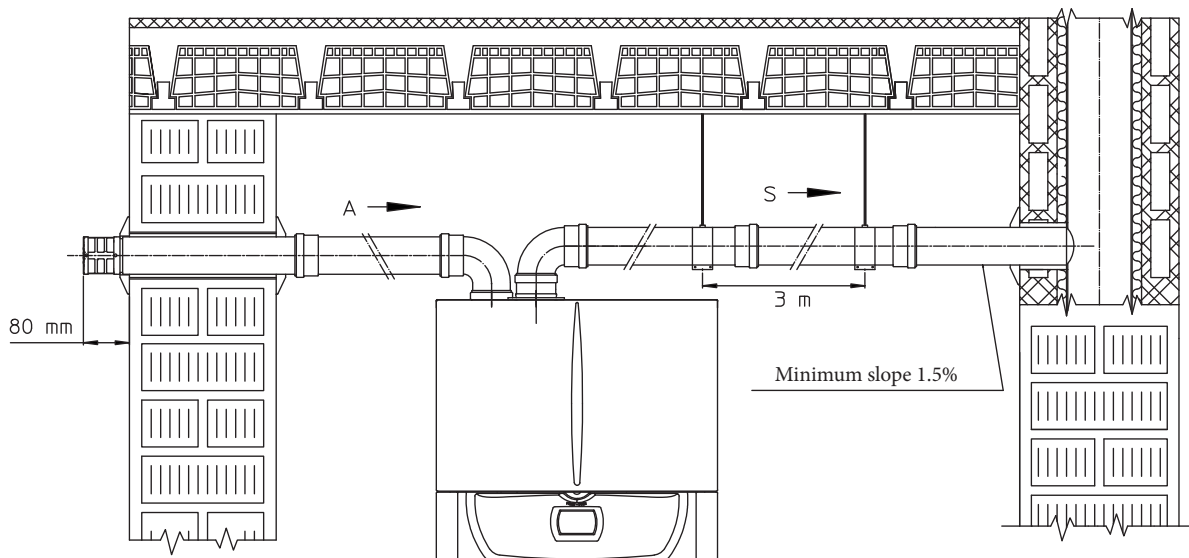

21

### 1.16 ADAPTOR C9 KIT INSTALLATION.

This kit allows an Immergas boiler to be installed in "C<sub>93</sub>" configuration, with combustion air intake directly from the shaft where the flue gas exhaust is, obtained by means of a ducting system.

#### System composition.

The system must be combined with the following components (sold separately) to be functional and complete:

- kit C<sub>93</sub> Ø 100 or Ø125 version;
- rigid ducting Ø 60 and Ø 80 and flexible Ø 50 and Ø 80 kit;
- flue exhaust kit Ø 60/100 or Ø 80/125 configured according to the installation and type of boiler.

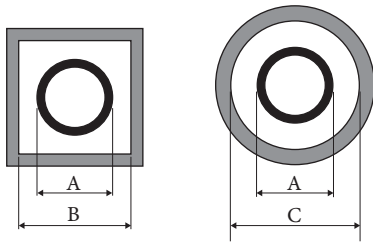

Ducting Ø 60 Rigid Ø 50 Flexible (A) mm	SHAFT (B) mm	SHAFT (C) mm
66	106	126

Ducting Ø 80 Rigid (A) mm	SHAFT (B) mm	SHAFT (C) mm
86	126	146

Ducting Ø 80 Flexible (A) mm	SHAFT (B) mm	SHAFT (C) mm
90	130	150

22

#### Kit Assembly.

- Mount the components of kit "C9" on the door (A) of the ducting system (Fig. 23).
- (Version Ø 125 only) mount the flanged adaptor (11) interposing the concentric gasket (10) on the boiler, fitting it with the screws (12).
- Mount the ducting system as described in the relative instructions sheet.
- Calculate the distances between the boiler drain and the bend of the ducting system.
- Prepare the boiler flue system, making sure that the internal pipe of the concentric kit is fitted up to the end stop in the ducting system curve (Quota "X" Fig. 24), whereas the external pipe must reach the end stop of the adapter (1).

**N.B.:** to encourage the removal of possible condensate forming in the exhaust pipe, tilt the pipes towards the boiler with a minimum slope of 1.5%.

- Mount the cover (A) complete with adaptor (1) and caps (6) on the wall and assemble the flue system to the ducting system.

**N.B.:** (version Ø 125 only) before assembly check the gaskets are in the right position. In the event component lubrication (already carried out by the manufacturer) is not sufficient, remove the residual lubricant using a dry cloth, then to ease fitting coat the parts with common or industrial talc.

Once all components have been assembled properly, the exhaust fumes will be expelled via the ducting system; the combustion air for normal boiler operation will be aspirated directly by the shaft (Fig. 24).

#### Kit composition:

Ref.	Qty	Description
1	1	Door adaptor Ø 100 or Ø 125
2	1	Door gasket made of neoprene
3	4	Screws 4.2 x 9 AF
4	1	Hex headed screw M6 x 20
5	1	Flat nylon washer M6
6	2	Door hole closure metal-sheet plate plug
7	1	Plug gasket made of neoprene
8	1	Toothed washer M6
9	1	Nut M6
10	1 (kit 80/125)	Concentric gasket Ø 60-100
11	1 (kit 80/125)	Flanged adapter Ø 80-125
12	4 (kit 80/125)	Hex headed screws M4 x 16 slotted
-	1 (kit 80/125)	Bag of lubricating talc

#### Supplied separately:

Ref.	Qty	Description
A	1	Ducting kit door

#### Installation drawings key:

- ① Unique identification of the component in the kit
- A Identification of the component not supplied in this kit

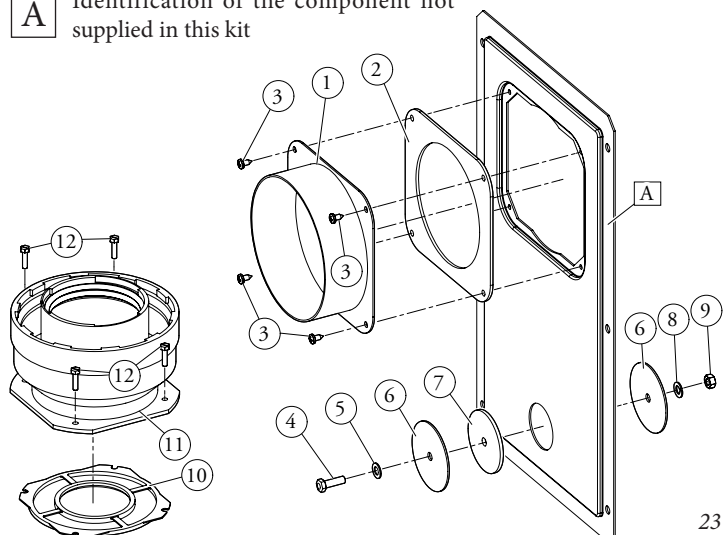

23

**Technical data.**

- The dimensions of the shafts must ensure a minimum gap between the outer wall of the smoke duct and the inner wall of the shaft: 30 mm for circular section shafts and 20 mm in the event of a square section shaft (Fig. 22).
- Maximum 2 changes of direction are allowed on the vertical section of the flue system with a maximum clearance angle of 30° with respect to the vertical.
- The maximum vertical extension using a Ø 60 ducting system is 13 m. the maximum extension includes 1 bend Ø 60/10 at 90°, 1 m of horizontal pipe 60/100, 1 90° ducted bend Ø 60 and the roof terminal for ducting.

To determine the  $C_{93}$  flue system in configurations other than that described (Fig. 24) one must consider that 1 metre of ducted pipe according to the indications described has a resistance factor equal to 4.9.

- The maximum vertical extension using a Ø 80 ducting system is 28 m. the maximum extension includes 1 adapter 60/100 to 80/125, 1 87° bend Ø 80/125, 1 m of horizontal pipe 80/125, 1 90° ducted bend Ø 80 and the roof terminal for ducting.

To determine the  $C_{93}$  flue system in configurations other than that described (Fig. 24) one must consider the following head losses:

- 1 m of concentric pipe Ø 80/125 = 1 m of ducted pipe;
- 1 87° bend = 1.4 m of ducted pipe;

Consequently one must subtract the equivalent length of the part added to the 28 m available.

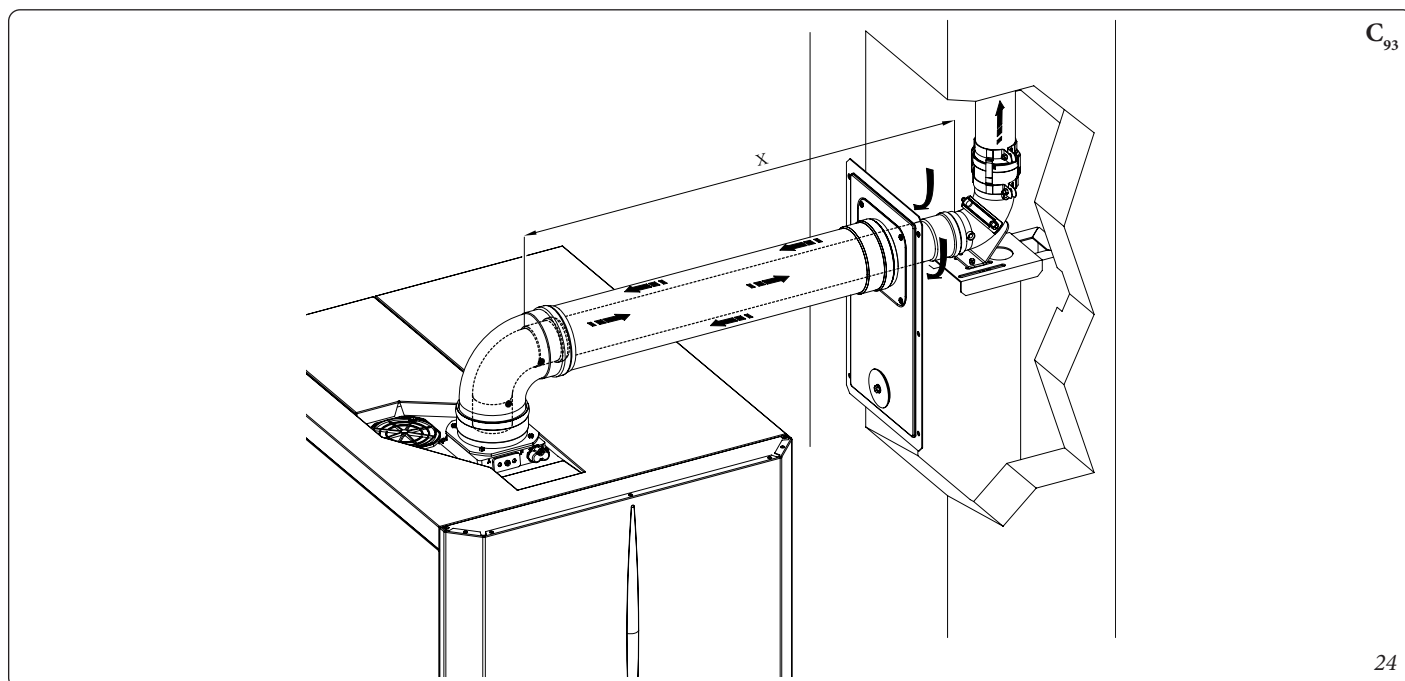

### 1.17 DUCTING OF FLUES OR TECHNICAL SLOTS.

Ducting is an operation through which by inserting one or more relevant pipes, one achieves a system for the evacuation of the combustion products of a gas appliance, consisting in the combination of an existing or new ducting pipe with a chimney, flue or technical slot (also in new buildings) (Fig. 25). Ducting requires ducts declared to be suitable for the purpose by the manufacturer, following the installation and user instructions, provided by the manufacturer and the requirements of the regulations in force.

#### Immergas ducting system.

*The Ø 60 rigid, Ø50 and Ø 80 flexible and Ø80 rigid "Green Range" ducting systems must only be used for domestic use and with Immergas condensing boilers.*

In any case, ducting operations must respect the provisions contained in the standard and in current technical regulations; in particular, the declaration of conformity must be compiled at the end of work and on commissioning of the ducted system. The instructions in the project or technical report must likewise be followed, in cases provided for by the standard and current technical regulations. The system or components of the system have a technical life complying with current standards, provided that:

- it is used in average atmospheric and environmental conditions, according to current regulations (absence of combustion products, dusts or gases that can alter the normal thermophysical or chemical conditions; existence of temperatures coming within the standard range of daily variation, etc.).

- Installation and maintenance must be performed according to the indications supplied by the manufacturer and in compliance with the regulations in force.
- The maximum length specified by the manufacturer must be respected; in this regard:

- The max. possible length of the Ø 60 flexible ducting vertical section is equal to 22 m. This length is obtained considering the complete Ø 80 exhaust terminal, 1m of Ø 80 pipe in exhaust, two 90° Ø 80 bends at boiler outlet.
- The max. possible length of the Ø 80 flexible ducting vertical section is equal to 18 m. This length is obtained considering the Ø80 complete exhaust terminal, 1m of Ø 80 pipe in exhaust, two 90° Ø 80 bends at boiler outlet for connecting to the ducting system and two direction changes of the flexible hose inside the chimney/technical slot.
- The max. possible length of the Ø 80 flexible ducting vertical section is equal to 30 m. This length is obtained considering the complete Ø 80 exhaust terminal, 1m of Ø 80 pipe in exhaust, two 90° Ø 80 bends at boiler outlet.

You can also install an additional Ø50 flexible ducting system the specifications of which are found on the relevant instructions sheet inside the kit.

### 1.18 CONFIGURATION TYPE B, OPEN CHAMBER AND FAN ASSISTED FOR INDOORS.

The appliance can be installed inside buildings in B<sub>23</sub> or B<sub>53</sub> mode; in this case, all technical rules and national and local regulations in force, must be complied with.

For installation the cover kit must be used, referred to in (Par. 1.12).

### 1.19 FLUE EXHAUST TO FLUE/CHIMNEY.

The flue exhaust does not necessarily have to be connected to a branched type traditional flue. The flue exhaust, for boiler clots installed in C configuration, can be connected to a special LAS type multiple flue. For B<sub>23</sub> configurations, exhaust is only allowed into individual chimney or directly into the external atmosphere via a suitable terminal, unless otherwise provided for by local regulations in force. The multiple flues and the combined flues must also only be connected to type C appliances of the same type (condensing), having nominal heat inputs that do not differ by more than 30% less with respect to the maximum that can be attached and powered by the same fuel. The thermo-fluid dynamic features (flue flow rate, % of carbon dioxide, % humidity etc....) of the appliances attached to the same multiple flues or combined flue, must not differ by more than 10% with respect to the average boiler attached. Multiple and combined flues must be specially designed according to the calculation method and requirements of the technical standards in force (such as EN 13384), by a professionally qualified company. Chimney or flue sections for connection of the exhaust pipe must comply with requisites of technical standards in force. It is possible to replace a type C conventional device with one provided with condensation only, if the derogation conditions established by the regulations in force have been verified.

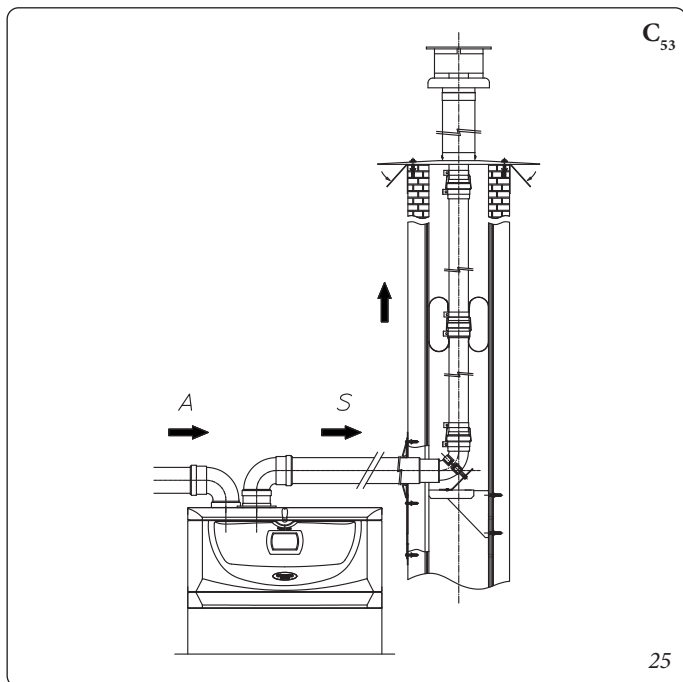

## 1.20 FLUES, CHIMNEYS AND CHIMNEY CAPS.

The flues, chimneys and chimney caps for the evacuation of combustion products must be in compliance with applicable standards. Chimneys and roof-installed exhaust terminals must comply with the outlet height and with the distance from technical volumes set forth by the technical standards in force.

### Positioning the wall flue exhaust terminals.

The wall flue exhaust terminals must:

- be installed on external perimeter walls of the building (Fig. 26);
- be positioned according to the minimum distances specified in current technical standards.

### Combustion products exhaust of natural draught or fan assisted appliances in open-top closed environments.

In spaces closed on all sides with open tops (ventilation pits, courtyards etc.), direct combustion product exhaust is allowed for natural draught or fan assisted gas appliances with a heat input range from 4 to 35 kW, provided the conditions as per the current technical standards are respected.

## 1.21 SYSTEM FILLING.

Once the boiler is connected, proceed with system filling via the filling cock (Fig. 46). Filling is performed at low speed to ensure release of air bubbles in the water via the boiler and central heating system vents.

The pump may be noisy on start-up due to the presence of air. This noise should stop after a few minutes of functioning and however after having correctly bled the air contained in the hydraulic circuit.

The boiler incorporates an automatic vent valve positioned on the boiler pump and one positioned on the hydraulic manifold. *Make sure that the hoods are loosened.* Open the radiator vent valves. Close radiator vent valves when only water escapes from them. Close the filling cock when the boiler pressure gauge indicates approx. 1.2 bar.

**N.B.:** during these operations, turn on the circulating pump at intervals using the main switch on the control panel. *Vent the circulation pump by loosening the front cap and keeping the motor running and assuring that the liquid that escapes cannot cause injury/damage to persons/objects.* Tighten the cap after the operation.

### ATTENTION:

**to carry out the filling procedure correctly, activate the “automatic vent” function”**



## 1.22 FILLING THE CONDENSATE DRAIN TRAP.

On first lighting of the boiler, flue gas may come out the condensate drain; after a few minutes' operation check that this no longer occurs. This means that the drain trap is filled with condensate to the correct level preventing the passage of flue gas.

## 1.23 GAS SYSTEM START-UP.

To start up the system, refer to the technical standards in force.

In particular, for new gas systems:

- open windows and doors;
- avoid presence of sparks or naked flames;
- bleed all air from pipelines;
- ensure the internal system is properly sealed according to the specifications set forth by technical regulations in force.

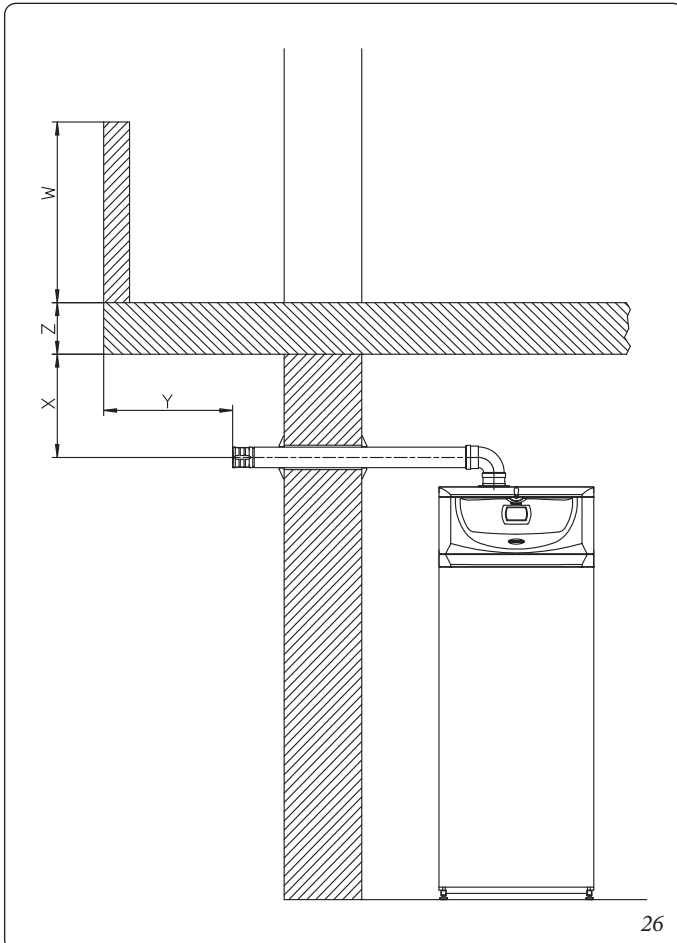

## 1.24 SOLAR CIRCUIT START-UP.

**Preliminary checks.** Before filling the hydraulic circuit and starting the system, carry out the following checks:

- ensure that the declaration of conformity of installation of the solar system is supplied with the appliance;
- check the functionality of the safety devices, particularly:
  - safety valve (6 bar)
  - expansion vessel
  - thermostatic mixing valve
- make sure there are no leaks in the hydraulic circuit;
- make sure there is an air vent valve positioned in the highest point of the circuit above the manifold and that it is operational.

If even only a single safety check offers a negative result, do not commission the system.

### **Expansion vessel factory-set pressure of the solar circuit hydraulic unit.**

To compensate the high temperatures that can be reached by the liquid in the circuit and therefore its dilation, an expansion vessel has been envisioned that has sufficient capacity to perform this task.

The expansion vessels are supplied pre-loaded at 2.5 bar. It is therefore necessary to deflate them and reload them at the pressure required for the circuit.

The expansion vessel must be charged to:

**1.5 bar + 0.1 bar for every metre of the water column.**

“*metre of the water column*” means the vertical distance that is present between the expansion vessel and the solar manifold.

Example:

The circulation unit is found on the ground floor and the solar manifold is found on the roof at a hypothetical height of 6 m. the distance to be calculated is:

$$6 \text{ m} \times 0.1 \text{ bar} = 0.6 \text{ bar}$$

therefore the expansion vessel must be charged to:

$$1.5 + 0.6 = \mathbf{2.1 \text{ bar}}$$

### **Hydraulic unit safety valve.**

There is a safety valve present on the hydraulic unit that protects the system from an excessive increase in pressure. This valve intervenes by discharging the liquid contained in the circuit when the pressure reaches 6 bar.

If the safety valve intervenes and therefore part of the liquid contained in the circuit is lost, it must be re-integrated.

## 1.25 SOLAR CIRCUIT FILLING.

**ATTENTION:**

**If errors occur during installation, operation and maintenance, due to non compliance with the technical laws in force, standards or instructions contained in this manual (or however supplied by the manufacturer), the manufacturer accepts no contractual and extra-contractual liability for any damages and the appliance warranty is invalidated.**



The system can only be filled when:

- any operational residues have been eliminated that may cause obstructions and deteriorate the features of the glycol over time;
- any presence of water in the system has been eliminated, which could otherwise cause damage to the system in winter;
- the absence of leaks has been verified by checks using air;
- the storage tank unit has been filled;
- the expansion vessel has been charged according to system requirements.

The system must be filled only using the glycol supplied by Immergas via an automatic pump. The system must be filled with vent valve closed.

Proceed as follows to fill the system (Fig. 33):

- 1 connect the flow pipe of the automatic pump to the fitting of the filling valve (9) located under the pump and open the valve.
- 2 connect the return pipe of the automatic pump to the fitting of the draining valve (8) and open the draining valve.
- 3 The flow-rate regulator screw (11) must be orientated horizontally to ensure the closure of the integrated ball valve. Open the ball valve with thermometer (2) above the pump.
- 4 fill the filling pump tank with the amount of glycol necessary plus a minimum amount to be left on the bottom of the tank in order to prevent air circulating inside the circuit.
- 5 The filling stage must have a minimum duration of 20 ÷ 25 minutes. This time is required to completely remove all air from the circuit. Every now and again open the flow rate regulator adjustment screw in order to eliminate air from inside (vertical position).
- 6 Eliminate any air in the solar circuit preferably using the so-called “pressure shot” method, which consists in raising the filling pressure of the circuit followed by a quick opening of the return valve (8). This method allows air to be expelled from the circuit.
- 7 Close the filling cock and switch the filling pump off, open the regulator screw of the flow rate regulator (notch in vertical position).
- 8 Leave the circuit pressurised. Any pressure drop indicates a leak in the system.
- 9 Set the functioning pressure in the circuit at 1.5 bar + 0.1 bar for every metre in the distance between the solar manifold and the expansion vessel (practically, set the same pressure between expansion vessel and system).

**ATTENTION:**

**Do not exceed 2.5 bar.**



10 Switch the solar pump on at a maximum speed and make it run for at least 15 minutes.

11 Disconnect the filling pump and close the fittings using the relevant screw caps.

12 Open the ball valve above the pump completely.

**ATTENTION:**

**Do not fill the system in conditions with strong insolation and with the manifolds at high temperatures.**



**Make sure that all air bubbles have been completely eliminated.**

**Solar circuit vent.**

Any air present in the system must be bled:

- on start-up (after filling);
- if necessary, e.g. in the case of breakdown.

**ATTENTION:**

**danger of burns from the liquid contained in the collectors.**





### 1.26 BOILER START UP (IGNITION).

To commission the boiler (the operations listed below must only be performed by a qualified firm and without any unauthorised persons):

- check that the internal system is properly sealed according to the specifications set forth by technical regulations in force;
- make sure that the type of gas used corresponds to boiler settings;
- Check that there are external factors that may cause the formation of fuel pockets;
- switch the boiler on and check correct ignition;
- make sure that the gas flow rate and relevant pressure values comply with those given in the manual (Par. 4.1);
- ensure that the safety device intervenes in the event of gas supply failure and check the relative intervention time;
- check the intervention of the main switch located upstream from the boiler and in the boiler;
- check that the intake and/or exhaust terminals (if fitted) are not blocked.

The boiler must not be started up even if only one of the checks should be negative.

### 1.27 DHW MIXING VALVE.

The thermostatic mixing valve mixes the cold water with the hot water and via an internal wax element, sensitive to the temperature, automatically controls the temperature of the mixed water set by the user.

For excellent management of the temperatures, the mixing valve must be set by the installer at a safety temperature required by the user. The outlet temperature of the domestic hot water can also depend on the value set on the boiler, however, the upper limit temperature value of the domestic hot water is always determined by the position of the mixing valve: knob position 1 = 42°C, 2 = 48°C, 3 = 54°C, 4 = 60°C (standard) (the values indicated refer to a storage tank with water at 70°C).



**Any release of the three-way mixing valve.** If after a long period of inactivity the three-way mixing valve is blocked, it is necessary to act manually on the knob positioned on the top of the same in a way to release the shutter of the valve itself.

INSTALLER

USER

MAINTENANCE TECHNICIAN

## 1.28 CIRCULATION PUMP.

Boilers in the “Hercule Solar 26 2 ErP” series are supplied with 2 types of circulating pumps. Set operation modes according to one’s installation requirements.

- **Boiler circulator pump.** The circulator pump is not equipped with speed selector. To change operation mode, parameter “P57” in the “M5” boiler menu must be changed.

**Pump release.** If the pump should be blocked after a long period of inactivity, it must be released. Loosen the front cap, making sure that the liquid that escapes cannot cause injury/damage to persons/objects and turn the motor shaft very carefully using a screwdriver so as not to damage the latter. Once the pump is released, close the vent cap.

- **Zone 1 circulator pump.** The pump is ideal for the requirements of each central heating system in a domestic and residential environment. In fact, the pump is equipped with electronic control that allows to set advanced functions.

**Adjustments.** Turn the selector and set it on the desired curve to adjust the circulator pump.

Program	LED
P 1 lower ( $\Delta P-V$ )	green
P 2 upper ( $\Delta P-V$ )	
C 3 lower ( $\Delta P-C$ ) - H=3 m	orange
C 4 upper ( $\Delta P-C$ ) - H=4 m	
Min - Max	blue

**Program P (1 lower 2 upper) ( $\Delta P-V$ ) - Proportional curve (green LED).** This allows the pressure level (head) to be proportionally reduced as the system heat demand decreases (flow rate reduction). Thanks to this function, the electric power consumption of the circulator pump is reduced further: the energy (power) used by the pump decreases according to the pressure level and flow rate. With this setting, the pump guarantees optimal performance in most heating systems, thereby being particularly suitable in single-pipe and two-pipe installations. Any noise of the water flow in the pipes, valves and radiators is eliminated by reducing the head. Optimal conditions for thermal comfort and acoustic well-being.

**Programs C (3 lower 4 upper) ( $\Delta P-C$ ) - Constant curve (orange LED).** The circulator pump maintains the pressure level (head) constant as the system heat demand decreases (flow rate reduction). With these settings, the circulator pump is suitable for all floor systems where all the circuits must be balanced for the same drop in head.

**MIN-MAX Program (Blue LED).** The pump is distinguished by adjustable operating curves by positioning the selector in any point between the Min and Max positions, thereby satisfying any installation requirement (from a simple single-pipe to more modern and sophisticated systems) and always guarantee optimum performance. The precise working point can be selected in the entire field of use by gradually adjusting the speed.

**Real time diagnostics:** a lit LED (in various colours) provides information regarding the pump operating status, see fig. 27.

**Possible pump release.** The pump block is indicated by a fixed red LED switching on. Turn the selector up to the MAX position, disconnect and reconnect the power to restart the automatic release process. The pump will then activate the procedure that will last a maximum of 15 minutes and the LED will flash upon each restart. It then turns blue for a few seconds and goes back to red if the attempt to restart is not successful. Once the process is complete, set the selector back to the desired curve and if the problem has not been resolved, perform the manual release procedure as described below.

- Disconnect the power to the boiler (the LED switches off).
- Close the system flow and return and let the pump cool down.
- Empty the system circuit via the relative cock.
- Remove the motor and clean the impeller.
- Once unblocked, remount the motor.
- Fill the primary circuit; restore boiler power and set the desired curve.

### ATTENTION:

**there is a burns hazard due to high fluid temperature and pressure. Burns hazard from coming in contact.**



Circulating pump LED	Description	Diagnostics	Remedy
LED steady on	Pump noisy	Insufficient system pressure. circulating pump in cavitation	Restore correct thermal circuit pressure
Flashing white LED	Noises during circulation of the heat transfer fluid	Presence of foreign matter in the impeller	Remove the motor and clean the impeller
LED steady on		Presence of air in the system	Vent the system
LED off	The circulator does not work	Flow rate too high	Reduce rotation speed
Red LED		Power outage	Ensure the boiler is correctly powered. ensure the circulator is correctly powered
		Faulty circulating pump	Replace the circulating pump
		Rotor seized	Remove the motor and clean the impeller
		Insufficient power supply voltage	Check boiler power supply voltage

Head available to the direct zone system fixed speed.

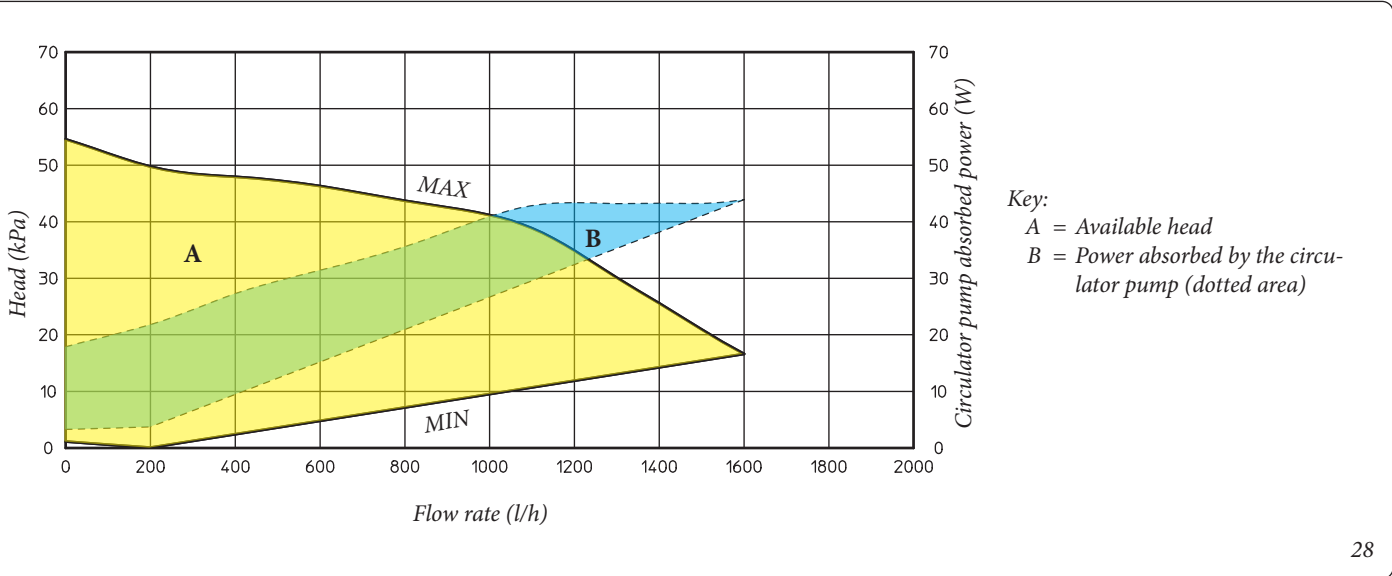

Head available to the direct zone system proportional or constant speed.

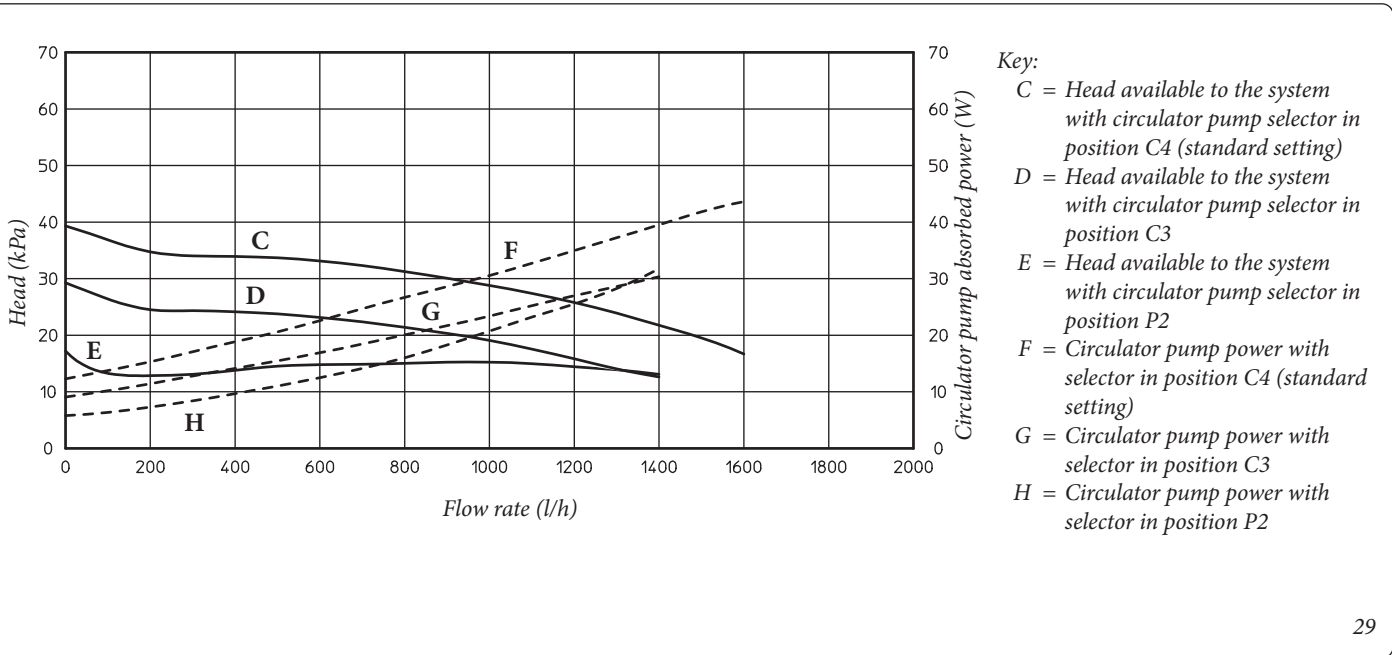

### 1.29 SOLAR CIRCUIT CIRCULATION PUMP.

The units are supplied with circulating pumps fitted with speed regulator.

These settings are suitable for most systems.

In fact, the pump is equipped with electronic control to set advanced functions. For proper operation one must select the most suitable type of operation for the system and select a speed in the available range, with a focus on energy savings.

**Display of operation status.** During normal operation the status LED (2) is on green (flashing (FL) when it is in stand-by), the four yellow LEDs (3) indicate circulator absorption according to the following table:

Circulating pump LED	Absorption
 FL Off Off Off Off	Circulator in stand-by
 On On Off Off Off	0 ÷ 25 %
 On On On Off Off	25 ÷ 50 %
 On On On On Off	50 ÷ 75 %
 On On On On On	75 ÷ 100 %

**Selection of operating mode.** To see the current operation mode it is sufficient to press button (1) once.

To change operation mode press the button for between 2 to 10 seconds until the current configuration flashing, each time the button is pressed all possible functions are scrolled cyclically according to the table (Fig. 31). After a few seconds without doing any operation the circulator memorises the selected mode and goes back to operation display.

- Constant curve: the circulator works maintaining system head constant. The circulator working point will move up or down according to the system's demand.

- PWM Profile: **do not use this operation mode.**

**Selection button lock.** The button has a feature that locks its operation to prevent accidental modifications, to lock the control panel it is necessary to press button (1) longer than 10 seconds (during which the current configuration flashes), the active lock is signalled by all LEDs of the control panel flashing. To unlock the button press again longer than 10 seconds.

**Real time diagnostics:** in the event of malfunction the LEDs provide information on the circulator operation status, see table (Fig. 32):

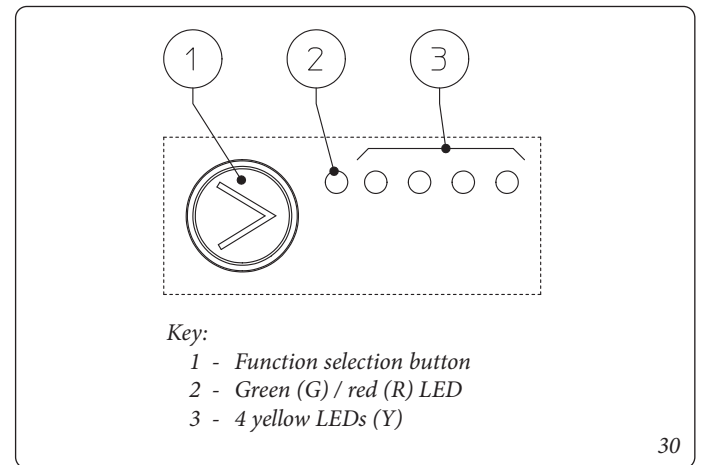

Circulating pump LED	Description
 On On On Off Off	Constant curve speed 1
 On On On On Off	Constant curve speed 2
 On On On On On	Constant curve speed 3
 On On On Off On	Constant curve speed 4 <b>(default)</b>

DO NOT USE	
Circulating pump LED	Description
 On Off On Off Off	PWM Profile speed 1
 On Off On On Off	PWM Profile speed 2
 On Off On On On	PWM Profile speed 3
 On Off On Off On	PWM Profile speed 4

Circulating pump LED (first red LED)	Description	Diagnostics	Remedy
R    Y    Y    Y    Y ●   ○   ○   ○   ● On Off Off Off On	Circulator pump blocked	The circulator pump cannot restart automatically due to an anomaly	Wait for the circulator to make automatic release attempts or manually release the motor shaft acting on the screw in the centre of the head. If the anomaly persists replace the circulator.
R    Y    Y    Y    Y ●   ○   ○   ●   ○ On Off Off On Off	Abnormal situation (the circulator continues operating). low power supply voltage	Voltage off range	Check power supply
R    Y    Y    Y    Y ●   ○   ●   ○   ○ On Off On Off Off	Electrical fault (Circulator pump blocked)	The circulator is locked due to power supply too low or serious malfunction	Check the power supply, if the anomaly persists replace the circulator

### 1.30 AUTO SOLAR CIRCULATION PUMP WITH NEW WAVE 3 ELECTRONICS.

The units are supplied with circulating pumps fitted with speed regulator.

These settings are suitable for most systems.

In fact, the pump is equipped with electronic control to set advanced functions. For proper operation one must select the most suitable type of operation for the system and select a speed in the available range, with a focus on energy savings.

#### Display of operation status (Fig. 33).

When the pump starts, the LED (2) lights up green for about 2 seconds, followed by short flashing at great intensity to then switch off during normal operation. The LED (3) only lights up in PWM setting, not used in the application. The three yellow LEDs (4) indicate the three constant curve speeds.

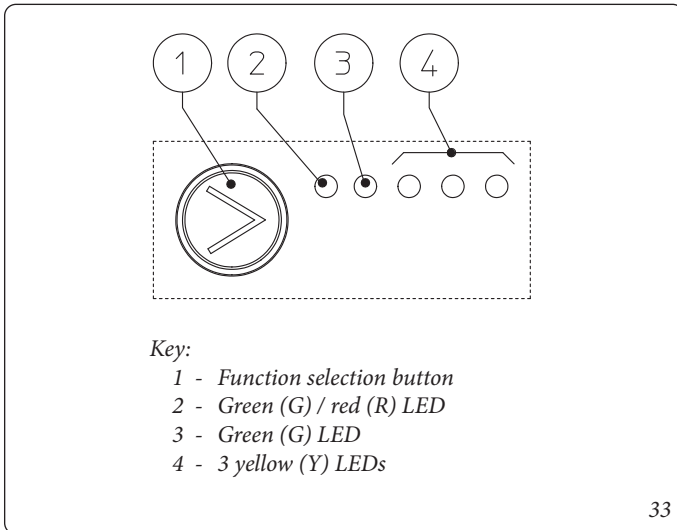

33

#### Selection of operating mode.

The operating mode is always visible and indicated by the 3 yellow LEDs (4).

**Info:** All the LEDs are off when the pump is not powered.

Press the button (1) to change operating mode.

Every time the button is pressed, all the possible functions are scrolled cyclically according to the following table:

Circulating pump LED	Description
G G Y Y Y ○ ○ ● ○ ○	Constant curve speed 1
G G Y Y Y ○ ○ ● ● ○	Constant curve speed 2
G G Y Y Y ○ ○ ● ● ●	Constant curve speed 3
G G Y Y Y ○ ● ● ● ●	PWM - Do not use
G G Y Y Y ○ ●* ● ● ●	PWM - Do not use

- Constant curve: the pump works maintaining system head constant. The pump working point will move up or down according to the system's demand.

#### ATTENTION:

**PWM Profile: do not use this operating mode. If this profile is selected, the pump will stop.**



For the "Hercules Solar 26 2 ErP" boiler, the pump is set at "Constant curve speed 3" by default.

**Real time diagnostics:** in the event of malfunction the LEDs provide information on the pump operation status, see table (Fig. 34):

Circulating pump LED (first red LED)	Description	Diagnostics	Remedy
R Y Y Y Y ● ○ ○ ○ ●	Pump blocked mechanically	The pump cannot restart automatically due to an anomaly	Wait for the pump to make automatic release attempts or manually release the motor shaft acting on the screw in the centre of the head. If the anomaly persists replace the pump.
R Y Y Y Y ● ○ ○ ● ○	Abnormal situation (the pump continues operating). low power supply voltage	Voltage off range < 160 Vac	Check power supply
R Y Y Y Y ● ○ ● ○ ○	Electrical fault (Pump blocked)	The pump is locked due to power supply too low or serious malfunction	Check the power supply if the anomaly persists replace the pump

34

Solar circulation unit available head.

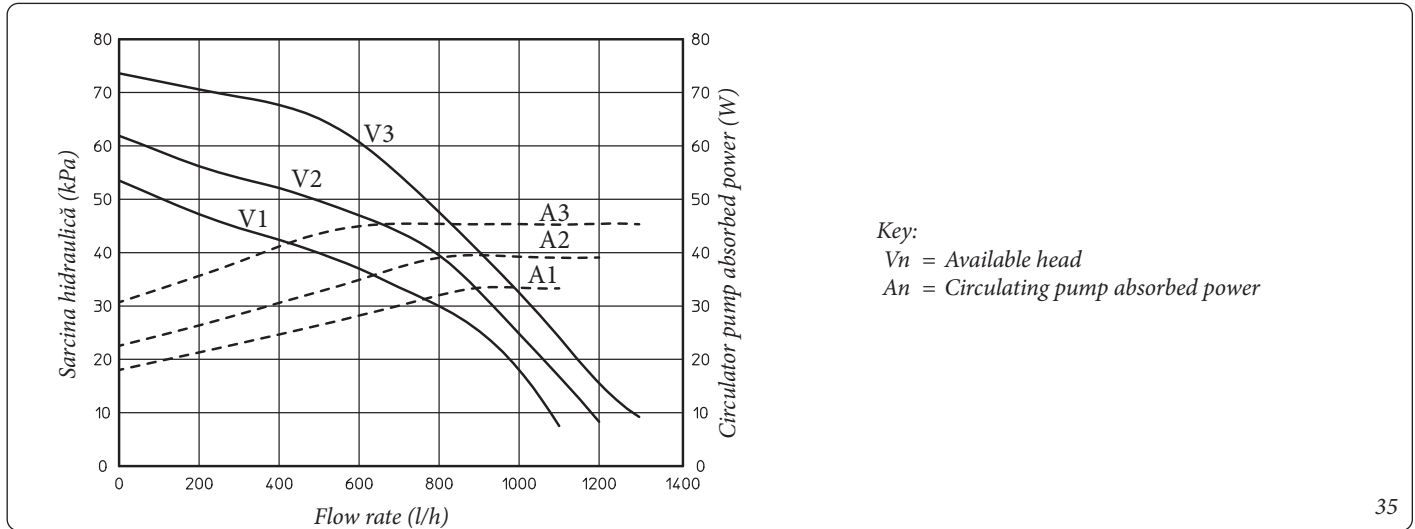

35

1.31 MAIN CIRCULATION UNIT COMPONENTS.

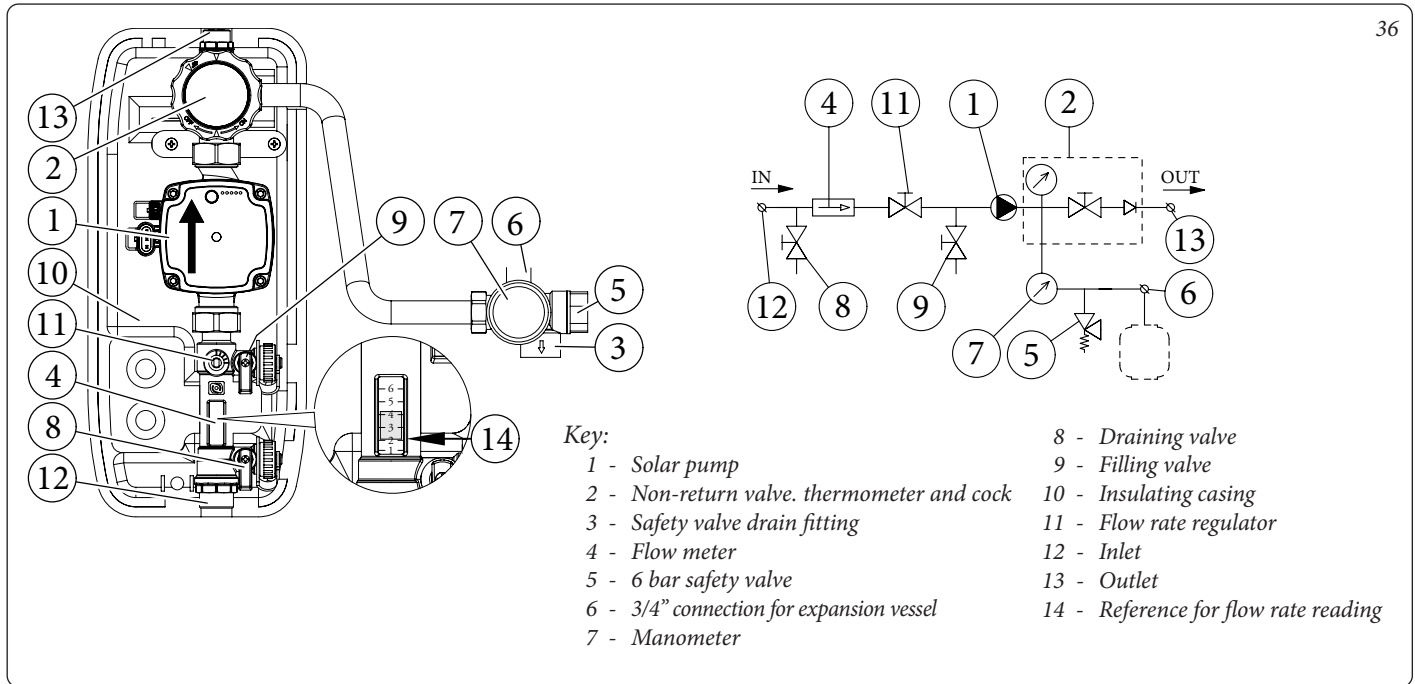

36

INSTALLER

USER

MAINTENANCE TECHNICIAN

**1.31 DOMESTIC HOT WATER STORAGE TANK UNIT.**

The “Hercules Solar 26 2 ErP” boiler is the storage tank type with a capacity of 200 litres. It contains large coiled stainless steel heat exchanger pipes, which allow to notably reduce hot water production times. These storage tank units constructed with stainless steel casing and bottoms, guarantee long duration through time. The assembly concepts and welding (T.I.G.) are implemented to the minimum detail to ensure maximum reliability.

The upper inspection flange ensures practical control of the storage tank unit and the coiled heat exchanger and easy internal cleaning. The DHW and the DHW pump connection couplings are positioned on the lid of the flange (cold inlet and hot outlet). The Magnesium Anode holder cap including the same, supplied as per standard for the internal protection of the storage tank from possible corrosion, is positioned on the side of the cylinder (part. 53 Fig. 38).

**Storage tank unit disassembly.** For easy maintenance or particular handling requirements, remove the cylinder as described below.

To disassemble the storage tank unit, empty the boiler system by acting on the relevant drain fitting. Before carrying out this operation, make sure that the system filling valves are closed. Close the cold water inlet valve and open any domestic hot water cock. Loosen the nuts on the system flow and return pipes (3) and the cold inlet and hot outlet nuts present on the storage tank unit (1). Empty the solar system via its drain fitting. Loosen the nuts (6) on the solar system flow and return pipes present on the cylinder. Loosen the nut (4) on the connection pipe to the DHW expansion vessel. Loosen the bracket fixing screws (2) Remove the screws (5) with the relative retainer brackets and slide the cylinder outwards on the relevant guides. Work in reverse order to assemble the storage tank unit.

Have the efficiency of the storage tank Magnesium Anode checked annually by a qualified firm (for example contact the Authorised Technical Service Centre). The storage tank unit is prepared for introduction of the domestic hot water pump fitting.

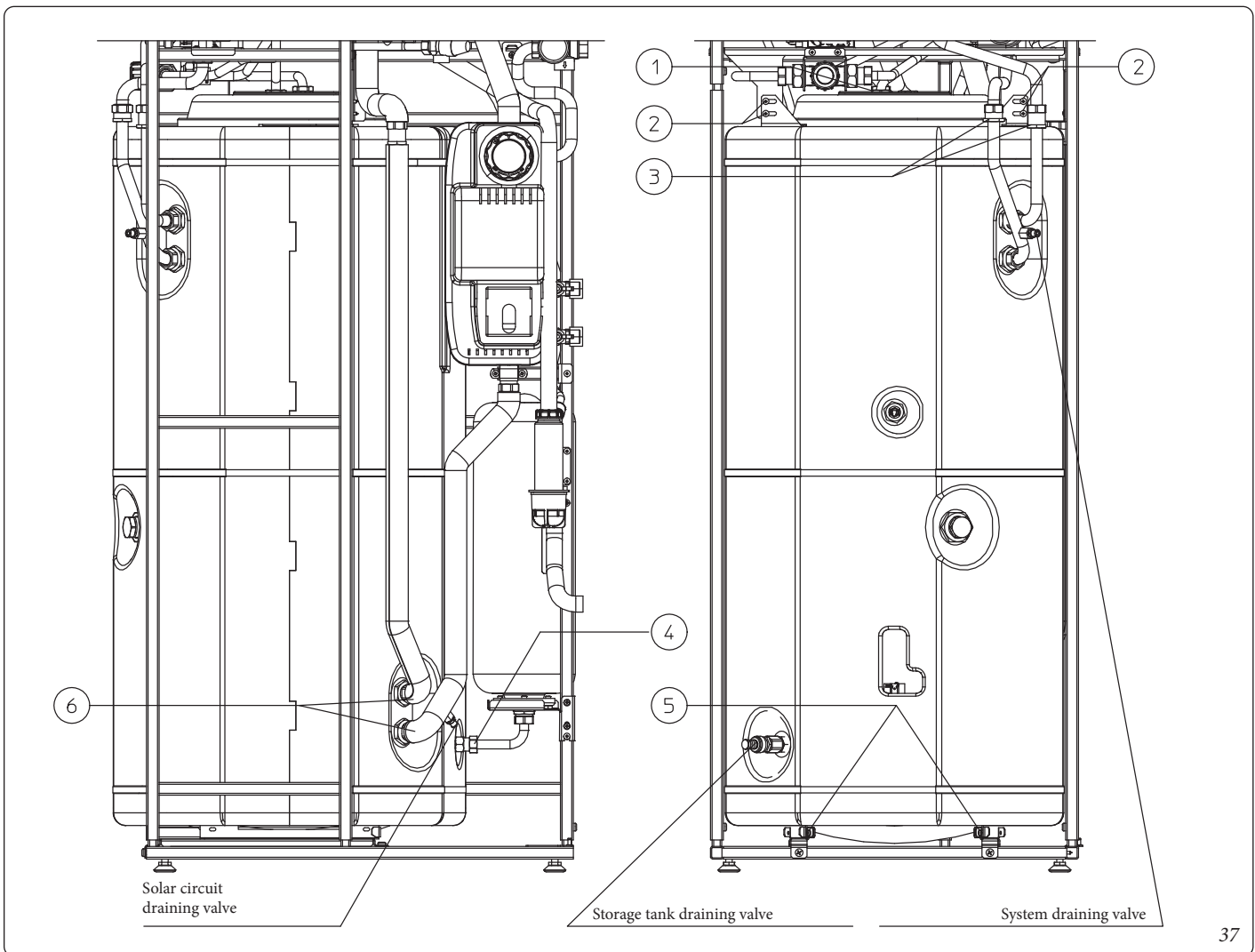



### 1.32 KITS AVAILABLE ON REQUEST.

- Recirculation kit (on request). The boiler storage tank unit is prepared for application of the pump kit. Immergas supplies a series of fittings and attachments that allow connection between the storage tank unit and domestic hot water system. The pump probe fitting is already inserted on the storage unit kit and the indication of the pump kit attachment is envisioned on the installation template.
- System cut-off valves kit (on request). The boiler is designed for installation of system interception cocks to be placed on flow and return pipes of the connection assembly. This kit is particularly useful for maintenance as it allows the boiler to be drained separately without having to empty the entire system.
- Polyphosphate dispenser kit (on request). The polyphosphate dispenser reduces the formation of lime-scale and preserves the original heat exchange and domestic hot water production conditions. The boiler is prepared for application of the polyphosphate dispenser kit.
- Zone pumps kit (on request). If the central heating system is to be divided into several zones (**max. three**) in order to interlock them with separate adjustments and to keep water flow rate high for each zone. Immergas supplies zone pump kits on request.
- Mixed zone kit (on request). If the central heating system is to be divided into direct zones (radiators) and mixed zone (floor plants) in order to interlock them with separate adjustments and to keep water flow rate high for each zone, Immergas supplies the mixed zone kit on request.
- Solar panels kit (on demand). If solar panels are to be used for the production of domestic hot water, Immergas supplies the solar panels kit on demand.
- Low temperature safety thermostat kit. With the boiler functioning in direct low temperature (no control downstream from the boiler), to prevent problems to the low temperature system a safety thermostat must be inserted onto the flow pipe.

The above-mentioned kits are supplied complete with instructions for assembly and use.

### 1.33 BOILER COMPONENTS.

INSTALLER

USER

MAINTENANCE TECHNICIAN

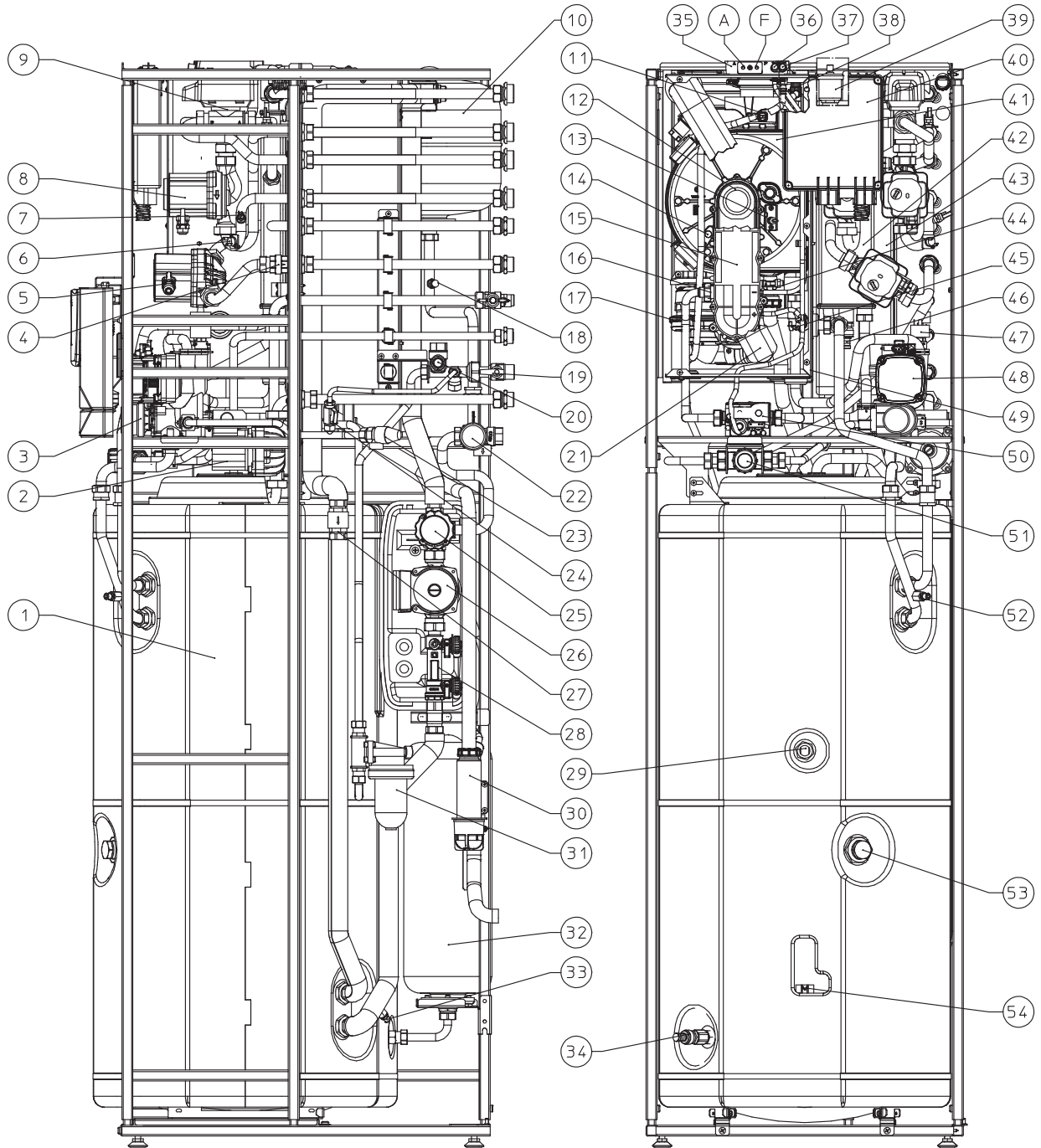

**Key**

- |   |   |  |
|---|---|--|
| 1 - Stainless steel storage tank unit         | 20 - 8 bar safety valve                   | 39 - Vent valve  |
| 2 - DHW recirculation pump (optional)         | 21 - Air intake pipe                      | 40 - Zones management electrical connection box (optional) |
| 3 - Three-way valve (motorised)               | 22 - Safety valve with manometer          | 41 - Condensation module                                   |
| 4 - Zone 1 one-way valve                      | 23 - 3 bar safety valve                   | 42 - Hydraulic manifold                                    |
| 5 - Zone 1 pump                               | 24 - System filling valve                 | 43 - System expansion vessel                               |
| 6 - Safety thermostat (mixed zone) (optional) | 25 - Shut-off valve with thermometer      | 44 - Delivery probe  |
| 7 - Flow probe (mixed zone) (optional)        | 26 - Solar pump                           | 45 - Safety thermostat                                     |
| 8 - Zone 2 pump (optional)                    | 27 - One-way solar valve                  | 46 - Manifold draining cock                                |
| 9 - Mixing valve (optional)                   | 28 - Flow meter                           | 47 - System pressure switch (absolute)                     |
| 10 - Solar expansion vessel                   | 29 - Domestic hot water probe             | 48 - Boiler Circulator                                     |
| 11 - Flue probe                               | 30 - Condensate drain trap                | 49 - Sealed Chamber  |
| 12 - Burner                                   | 31 - Polyphosphate dispenser (optional)   | 50 - Gas valve   |
| 13 - Ignition electrode                       | 32 - D.H.W. expansion vessel              | 51 - DHW mixing valve                                      |
| 14 - Detection electrode                      | 33 - Solar system drain fitting           | 52 - System draining valve                                 |
| 15 - Venturi                                  | 34 - Storage tank unit draining valve     | 53 - Magnesium anode                                       |
| 16 - Gas nozzle                               | 35 - Sample points (air A) - (flue gas F) | 54 - Cylinder solar probe                                  |
| 17 - Fan                                      | 36 - Positive signal pressure point       |  |
| 18 - Manual air vent valve                    | 37 - Negative signal pressure point       |  |
| 19 - Cold water inlet cock                    | 38 - Manual air vent valve                |  |

## 2 INSTRUCTIONS FOR USE AND MAINTENANCE.

### 2.1 GENERAL WARNINGS.

#### ATTENTION:



- The device can be used by children at least 8 years old as well as by persons with reduced physical, sensory or mental capabilities, or lack of experience or required knowledge, provided that they are under surveillance, or after they have been instructed relating to the safe use and have understood the potential dangers. Children must not play with the appliance. Cleaning and maintenance destined to be performed by the user can not be carried out by unsupervised children.
- For safety purposes, check that the air intake/flue exhaust terminals (if fitted) are not blocked.
- If temporary shutdown of the boiler is required, proceed as follows:
  - a) drain the heating system if antifreeze is not used;
  - b) shut-off all electrical, water and gas supplies.
- In the case of work or maintenance to structures located in the vicinity of ducting or devices for flue extraction and relative accessories, switch off the appliance and on completion of operations ensure that a qualified technician checks efficiency of the ducting or other devices.
- Never clean the appliance or connected parts with easily flammable substances.
- Never leave containers or flammable substances in the same environment as the appliance.

#### ATTENTION:



The use of components involving use of electrical power requires some fundamental rules to be observed such as:

- do not touch the appliance with wet or moist parts of the body; do not touch when bare-foot;
- never pull electrical cables or leave the appliance exposed to atmospheric agents (rain, sunlight, etc.);
- the appliance power cable must not be replaced by the user;
- in the event of damage to the cable, switch off the appliance and contact exclusively qualified staff for replacement;
- if the appliance is not to be used for a certain period, disconnect the main power switch.

INSTALLER

USER

#### ATTENTION:



water at a temperature of more than 50 °C can cause serious burns. Always check the water temperature before any use.

The temperatures indicated by the display have a tolerance of +/- 3°C due to environmental conditions that cannot be blamed on the boiler.



MAINTENANCE TECHNICIAN

**ATTENTION:**

if you smell gas in the building:



- close the gas meter interception device or the main interception device;
- if possible, close the gas interception cock on the product;
- if possible, open doors and windows wide and create an air current;
- do not use open flames (e.g. lighters, matches);
- do not smoke;
- do not use electrical switches, plugs, door bells, telephones or intercom devices in the building;
- call an authorised company (e.g. Authorised After-Sales Service).

**ATTENTION:**

if you smell burning or see smoke coming out of the appliance, switch it off. disconnect the power, close the main gas cock. open the windows and call an authorised company (e.g. Authorised After-Sales Service).

**ATTENTION:**

At the end of its service life, the appliance must not be disposed of like normal household waste nor abandoned in the environment, but must be removed by a professionally authorised company as required by current legislation. Contact the manufacturer for disposal instructions.



## 2.2 CLEANING AND MAINTENANCE.

To preserve the boiler's integrity and keep the safety features, performance and reliability which distinguish it unchanged over time, maintenance operations must be carried out on a yearly basis in compliance with that stated in the "annual check and maintenance of the appliance" section, in compliance with national, regional, or local standards in force.

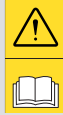

## 2.3 CONTROL PANEL.

Key:

- ⏻ - Stand-by - On Button
- A - Summer (☀️) and winter (❄️) operating mode button
- B - "COMFORT" (🏠) or "SAVING" domestic hot water function button
- C - Reset (RESET) / exit menu (ESC) button
- D - Menu entry button (MENU) / data confirmation (OK) button
- 1 - Domestic hot water temperature selector
- 2 - Domestic hot water temperature set
- 3 - Central heating temperature selector

- 4 - Central heating temperature set
- 4 - Presence of anomalies
- 6 - Display of boiler functioning status
- 8 - Flame presence symbol and relative power scale
- 9 and 7 - Primary heat exchanger outlet water temperature
- 10 - Boiler in stand-by
- 11 - Boiler connected to remote control (Optional)
- 12 - Functioning in summer mode
- 13 - Antifreeze function in progress
- 14 - Functioning in winter mode
- 15 - DHW functioning in "COMFORT" mode
- 16 - Presence of external connected devices
- 17 - Display of menu items
- 18 - Functioning with external temperature probe active
- 19 - Display of data confirmation or menu access
- 20 and 7- Outside temperature display with external probe connected (optional)
- 21 - Display of reset or exit menu request
- 22 - Chimney sweep function in progress
- 23 - Boiler manometer
- 24 - Multi-function display

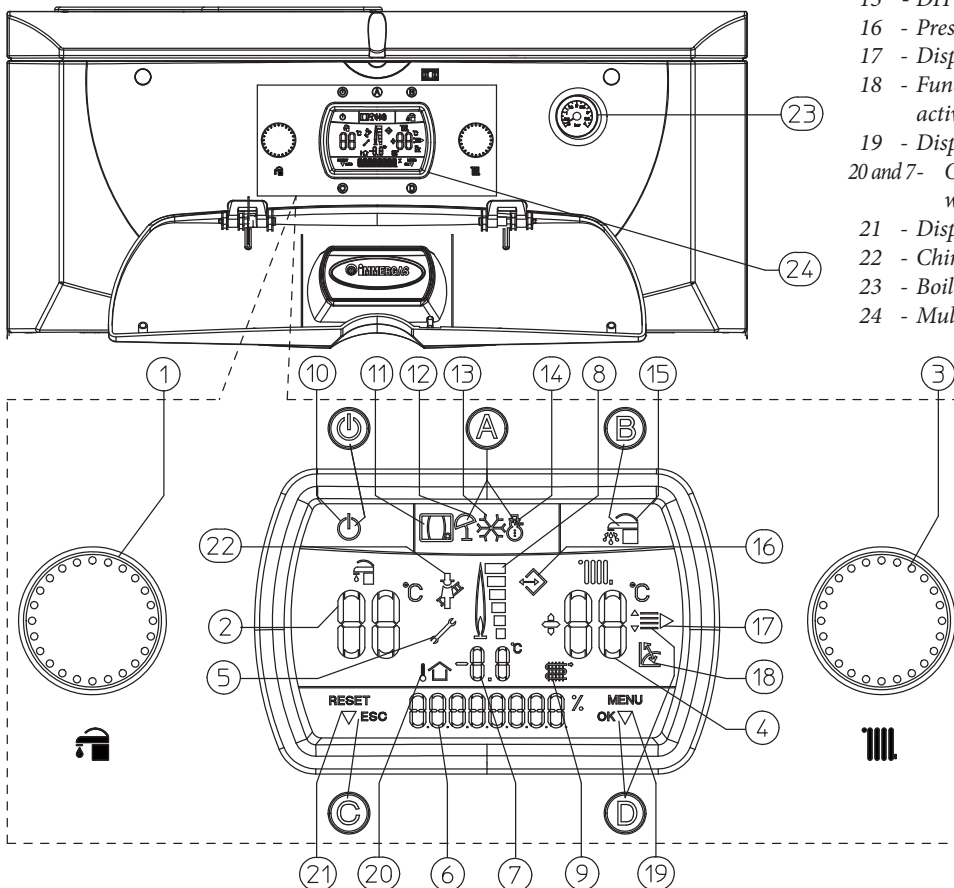

## 2.4 DESCRIPTION OF FUNCTIONING STATES

Below find a list of boiler functioning states that appear on the multifunction display (24) by means of the indicator (6) with a brief description. Refer to the instruction book for a complete explanation.

INSTALLER

USER

MAINTENANCE TECHNICIAN

Display (6)	Description of functioning states
SUMMER	Summer functioning mode without request in progress. Boiler in stand-by for domestic hot water request.
WINTER	Winter functioning mode without request in progress. Boiler in stand-by for domestic hot water or central heating request.
DHW ON	Domestic hot water mode in progress. Boiler functioning, domestic hot water heating in progress.
CH ON	Central heating mode in progress. Boiler functioning, central heating in progress.
F3	Antifreeze mode in progress. Boiler functioning to restore the minimum safety temperature against boiler freezing.
CAR OFF	Remote Control (Optional) off.
DHW OFF	In the case of use with Super CAR jointly with the operation period in reduced D.H.W. Timer mode, will be displayed DHW OFF and indicators 15 and 2 switch off (see Super CAR instructions manual).
F4	Postventilation in progress. Fan in function after a request for domestic hot water or central heating in order to evacuate residual flue gas.
F5	Postcirculation in progress. Pump in function after a request for domestic hot water or central heating in order to cool the primary circuit.
P33	With Remote Control (Optional) or room thermostat (TA) (Optional) in block, the boiler functions all the same in central heating mode. (Can be activated through menu "M3". It allows you to activate the central heating even if the Remote Control or TA are out of order).
STOP	Reset attempts finished Wait for 1 hour to re-acquire 1 attempt. (Error code 08).
ERR xx	Anomaly present with relative error code. The boiler does not work. (see troubleshooting paragraph).
SET	When the domestic hot water temperature selector switch is turned (1 Fig. 37) it displays the control status of the domestic hot water temperature in progress.
SET	When the central heating temperature selector switch is turned (3 Fig. 39) it displays the control status of the boiler flow temperature for room central heating.
SET	In the presence of the external probe (optional) replace the "SET" item. The value that appears is the correction of the flow temperature with respect to the functioning curve set by the external probe. See OFFSET on external probe graphics (Fig. 8).
F8	System deaeration in progress. During this phase, which lasts 18 hours, the boiler circulator pump is started at preset intervals, thus allowing deaeration of the central heating system.
F9	Only in the case of use with Super CAR, does it allow to activate the anti-legionella function, which takes the temperature of the water in the storage tank to 65°C for 15 minutes. (see Super CAR instruction manual).
SOLAR	Solar function. The solar function is activated to control just the pump for DHW. When the solar pump is powered, the display will show the text 'SOLAR', which may alternate with other function texts in progress.
SOLAR ON	The solar pump functions permanently.
SOLAR OFF	The solar pump stays off.

## 2.5 USING THE BOILER.

**Before ignition make sure the central heating system is filled with water and that the manometer (23) indicates a pressure of 1 - 1.2 bar;**

Open the gas cock upstream from the boiler. With the boiler off, only the Stand-by symbol (10) appears on the display. By pressing the (⏻) button the boiler switches on. Once the boiler is on, by pressing button “A” repeatedly, the functioning mode changes and switches from summer functioning mode (☀️) to winter functioning mode (❄️).

- **Solar circuit:** the operation of the solar circuit is completely automatic and does not require regulation by the user. The function is always active with the boiler on and must be kept so in the summer and in the winter. In the case of faults on the boiler, the solar circuit continues to function supplying heat to the water according to the possibility of the system and the weather conditions. Putting the boiler in stand-by (⏻) disables the solar function preventing disposal of the heat accumulated. It is therefore important to have the solar collector covered by qualified staff.

- **Summer (☀️):** in this mode the boiler functions only to heat domestic hot water. The temperature is set using the selector switch (1) and the relative temperature is shown on the display (24) by means of the indicator (2) and the “SET” indication is shown (Fig. 40). By turning the selector switch (1) in a clockwise direction the temperature increases and in an anti-clockwise direction it decreases.

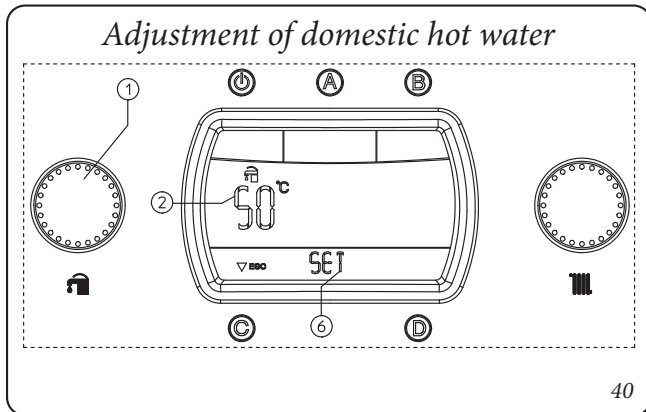

During domestic hot water heating, “DHW ON” is displayed (24) on the status indicator (6) and at the same time as the burner ignites, the flame presence indicator switches on (8) with the relative power scale and the indicator (9 and 7) with the instantaneous outlet temperature from the primary heat exchanger.

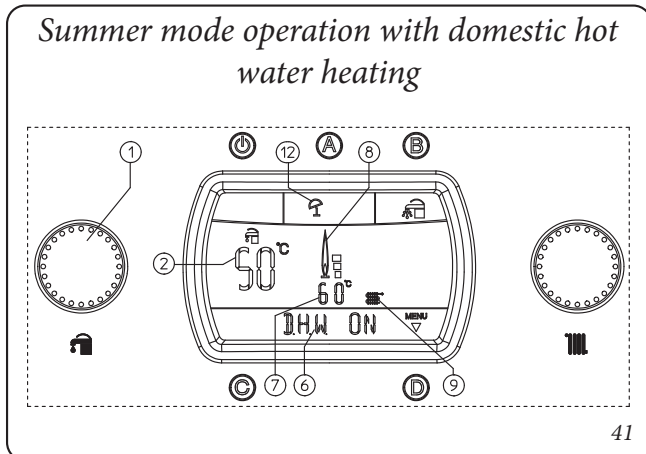

- **Winter (❄️):** in this mode the boiler functions both for heating domestic hot water and heating the environment. The temperature of the domestic hot water is always adjusted using the selector switch (1), the central heating temperature is adjusted using the selector switch (3) and the relative temperature is shown on the display (24) using the indicator (4) and the “SET” indication is shown (Fig. 42). By turning the selector switch (3) in a clockwise direction the temperature increases and in an anti-clockwise direction it decreases.

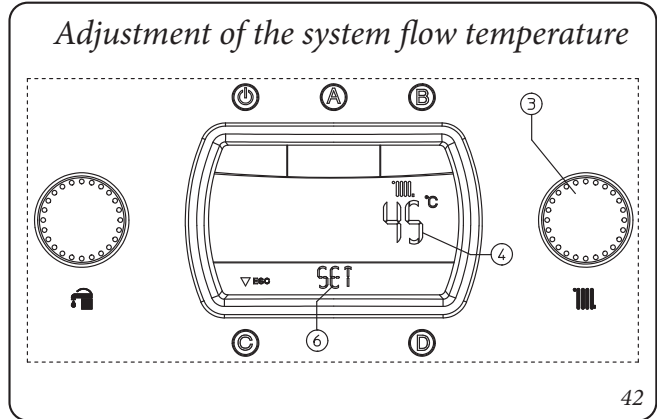

During the request for room heating the wording “CH ON” is displayed (24) on the status indicator (6) and at the same time as burner ignition the flame on indicator switches on (8) with relative power scale and the indicator (9 and 7) with the instantaneous outlet temperature from the primary heat exchanger. In the central heating phase, if the temperature of the water contained in the system is sufficient to heat the radiators, the boiler can only function with the activation of the boiler pump.

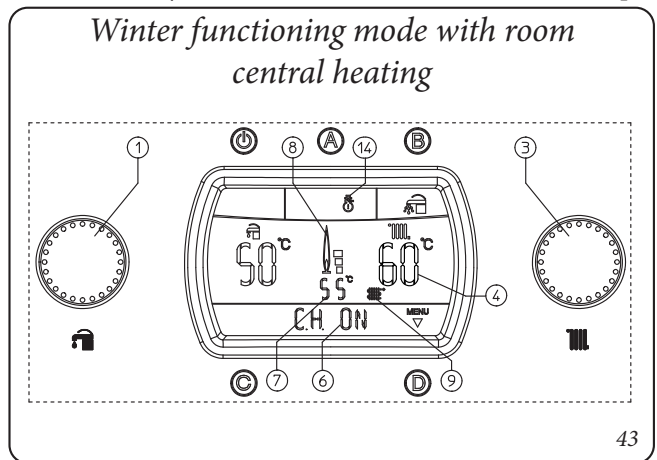

INSTALLER

USER

MAINTENANCE TECHNICIAN

- **Operation with Comando Amico Remoto remote control (CAR<sup>V2</sup>) (Optional).** In the event of connection to the CAR<sup>V2</sup> remote control, the boiler automatically detects the device and the symbol (  ) appears on the display. From this moment onwards all controls and adjustments are referred to the CAR<sup>V2</sup>. The stand-by button “U”, the Reset button “C”, the menu access button “D” and the DHW priority button “B” however remain active on the boiler.

**ATTENTION:**

If the boiler is put into stand-by (10)  the “CON” connection error symbol will appear on the CAR<sup>V2</sup> remote control. The CAR<sup>V2</sup> remote control is however constantly powered thus stored programs are not lost.

- **Operation with Super Comando Amico Remoto remote control (Super CAR) (Optional).** In the event of connection to the Super CAR remote control, the boiler automatically detects the device and the (  ) symbol appears on the display. From this moment it is possible to make adjustments indifferently from the Super CAR remote control or the boiler. Except for the central heating temperature that is shown on the display but managed by the Super CAR remote control.

**ATTENTION:**

If the boiler is put into stand-by (10)  the “ERR>CM” connection error symbol will be displayed on the Super CAR. The Super CAR remote control is however constantly powered thus stored programs are not lost.

- **“COMFORT” or “SAVING” DHW function.** Pressing button “B” on the display makes the (  ) symbol appear and the “COMFORT” function is activated, which allows you to have the maximum amount of water available set according to user requirements by adjusting the selector switch (1). The production of the hot water is guaranteed by the solar system and the boiler. Pressing button “B” again passes to “SAVING” mode, signalled by the indicator (15) off. In this way priority is given to the solar system to produce DHW, thus guaranteeing a minimum temperature of the water contained in the storage tank of 45°C. In this mode it is also possible to regulate the temperature of the water contained in the cylinder by acting on the selector switch (1).
- **Functioning with external probe (Fig. 44) optional.** In the case of a system with optional external probe, the boiler flow temperature for room central heating is managed by the external probe depending on the external temperature measured (Par. 1.9 and par. 3.11 under item “P66”). It is possible to modify the flow temperature from -15°C to +15°C with respect to the adjustment curve (Fig. 8 Offset value). This correction, which can be activated using selector switch (3) is kept active for any external temperature measured. The modification of the offset temperature is displayed via the indicator (7). The indicator (4) shows the current flow temperature and after a few seconds from the modification it is updated with the new correction. The “SET” indication is displayed (Fig. 44). By turning the selector switch (3) in a clockwise direction the temperature increases and in an anti-clockwise direction it decreases.

### System flow temperature adjustment with external probe (optional)

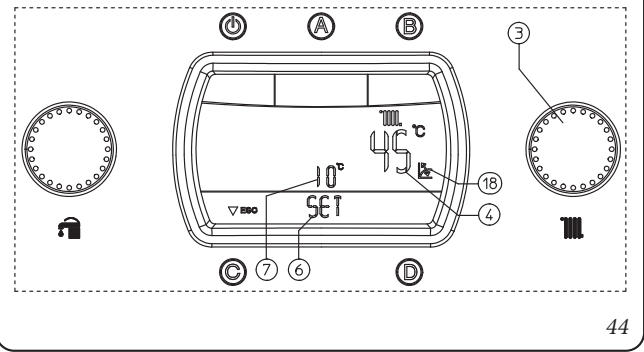

During the request for room heating the wording “CH ON” is displayed (24) on the status indicator (6) and at the same time as burner ignition the flame on indicator switches on (8) with relative power scale and the indicator (9 and 7) with the instantaneous outlet temperature from the primary heat exchanger. In the central heating phase, if the temperature of the water contained in the system is sufficient to heat the radiators, the boiler can only function with the activation of the boiler pump.

### Functioning in winter mode with external probe (optional)

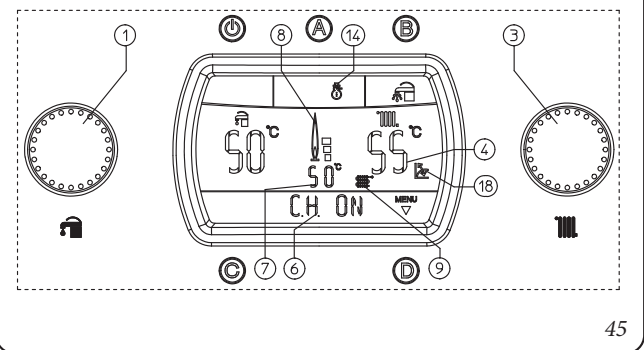

From this moment the boiler functions automatically. With no demand for heat (central heating or domestic hot water production) the boiler goes to “standby” function, equivalent to the boiler being powered without presence of flame.

**N.B.:** it is possible that the boiler may start-up automatically if the antifreeze function is activated (13). Moreover, the boiler can function for a brief period of time after a withdrawal of domestic hot water in order to take the domestic hot water temperature back into temperature.

**ATTENTION:**

with the boiler in stand-by mode. hot  water cannot be produced and the following safety functions are not ensured: pump anti-block device, antifreeze and three-way anti-block device.



## 2.6 TROUBLESHOOTING.

The Hercules Solar 26 2 ErP boiler signals any anomalies by the flashing symbol (5) along with the “ERRxx” indication on the indicator (6) where “xx” corresponds to the error code described in the following table. On the remote control, the error code will

be displayed by means of the same numeric code represented according to the following example (e.g. CAR<sup>V2</sup> = Exx. Super CAR = ERR>xx).

Error codes over 31 are not shown on the CAR<sup>V2</sup> and Super CAR display.



Error Code	Anomaly signalled	Cause	Boiler status / Solution
01	No ignition block	In the event of request of room central heating or domestic hot water production. the boiler does not switch on within the preset time. Upon appliance commissioning or after extended downtime. it may be necessary to eliminate the block.	Press the Reset button (1)
02	Safety thermostat block (overheating). flame control or fumes thermofuse anomaly	During normal operation. if a fault causes excessive overheating internally. the boiler goes into overheating block.	Press the Reset button (1)
03	Flue safety thermostat block	During normal operation, if a fault causes excessive flue gas overheating, the boiler blocks	Press the Reset button (1)
04	Contacts resistance block	Safety thermostat fault (overheating) or flame control anomaly.	Press the Reset button (1)
05	Flow probe anomaly	The board detects an anomaly on the flow NTC probe.	The boiler does not start (1)
08	Maximum N° of reset	Number of allowed resets that have already performed.	<b>Attention:</b> the anomaly can be reset 5 times consecutively, after which the function is inhibited for at least one hour. One attempt is gained every hour for a maximum of 5 attempts. By switching the appliance on and off the 5 attempts are re-acquired.
10	Insufficient system pressure	Water pressure inside the central heating circuit that is sufficient to guarantee the correct operation of the boiler is not detected.	Check on the boiler pressure gauge (1) that the system pressure is between 1+1.2 bar and restore the correct pressure if necessary.
12	Storage tank probe anomaly	The board detects an anomaly on the storage tank probe.	The boiler cannot produce domestic hot water
15	Configuration error	If the board detects an anomaly or incongruity on the electric wiring. the boiler will not start.	If normal conditions are restored the boiler restarts without having to be reset (1)
16	Fan anomaly	This occurs if the fan has a mechanical or electrical fault.	Press the Reset button (1)
20	Parasite flame block	This occurs in the event of a leak on the detection circuit or anomaly in the flame control unit.	Press the Reset button (1)
22	General alarm	This type of error is displayed on the CAR <sup>V2</sup> or Super CAR remote control in the event of faults or anomalies of the circuit boards or components not directly connected to boiler management: anomaly on the zones control unit, substation or solar circuit.	(1)
23	Return probe anomaly	The board detects an anomaly on the return NTC probe	The boiler does not start (1)
24	Push button control panel anomaly	The board detects an anomaly on the pushbutton panel	If normal conditions are restored the boiler restarts without having to be reset (1)

(1) If the shutdown or fault persists, contact an authorised firm (e.g. Authorised Technical After-Sales Service).  
 (2) Error codes over 31 are not shown on the CAR<sup>V2</sup> and Super CAR display.

INSTALLER

USER

MAINTENANCE TECHNICIAN

	Error Code	Anomaly signalled	Cause	Boiler status / Solution
INSTALLER	25	<b>Block due to flue gas temperature gradient intervention</b>	If the board detects a rapid increase in flue gas temperature probably due to a blocked circulating pump or lack of water in the heat exchanger, the boiler shuts down due to the flue gas temperature gradient trip.	Press the Reset button (1)
	27	<b>Insufficient circulation</b>	This occurs if there is overheating in the boiler due to insufficient water circulating in the primary circuit; the causes can be: - low system circulation; check that no shut-off devices are closed on the heating circuit and that the system is free of air (deaerated); - pump blocked; free the pump.	Press the Reset button (1).
	29	<b>Flue probe anomaly</b>	If the board detects an anomaly on the flue gas probe the boiler will not start	(1)
USER	31	<b>Loss of remote control communication</b>	This occurs if an incompatible remote control is connected, or if communication between the boiler and the remote control or Super CAR is lost.	Power cycle the boiler. If the Remote Control is still not detected on re-starting the boiler will switch to local operating mode, i.e. using the controls on the control panel. In this case the function "CH ON" cannot be activated. To make the boiler work in "CH ON" mode in any case, activate the "P33" function in the "M3" menu (1) (2).
	32	<b>Low temperature zone 2 probe anomaly</b>	If the board detects an anomaly on the mixed zone 2 probe, the boiler cannot work in the affected area.	(1) (2)
	33	<b>Low temperature zone 3 probe anomaly</b>	If the board detects an anomaly on the mixed zone 3 probe, the boiler cannot work in the affected area.	(1) (2)
	34	<b>Low temperature zone 2 safety thermostat intervention</b>	During operation, if a fault causes excessive over-heating internally on the mixed zone 2, the boiler does not satisfy the requests of the interested zone.	If normal conditions are restored the boiler restarts without needing to be reset (1) (2).
	35	<b>Low temperature zone 3 safety thermostat intervention</b>	During operation, if a fault causes excessive over-heating internally on the mixed zone 3, the boiler does not satisfy the requests of the interested zone.	If normal conditions are restored the boiler restarts without needing to be reset (1) (2).
MAINTENANCE TECHNICIAN	36	<b>IMG Bus communication loss</b>	Communication between the control units is interrupted due to an anomaly on the boiler control unit or on the IMG Bus.	The boiler does not satisfy the room heating requests (1) (2).
	37	<b>Low power supply voltage</b>	This occurs when the power supply voltage is lower than the allowed limits for the correct boiler operation.	If normal conditions are restored the boiler restarts without having to be reset (1) (2).
	38	<b>Loss of flame signal</b>	This occurs when the boiler is ignited correctly and the burner flame switches off unexpectedly; a new ignition attempt is performed and if normal conditions are restored, the boiler does not need to be reset (this fault can be checked in the list of errors in the "M1" menu only).	If normal conditions are restored the boiler restarts without having to be reset (1) (2).
	39	<b>Storage tank probe solar collector</b>	If the board detects an anomaly on the solar collector probe, the boiler continues to work regularly without the intake of solar energy for heating the DHW as the solar pump stops working.	(1)
<p>(1) If the shutdown or fault persists, contact an authorised firm (e.g. Authorised Technical After-Sales Service).</p> <p>(2) Error codes over 31 are not shown on the CAR<sup>v2</sup> and Super CAR display.</p>				

Error Code	Anomaly signalled	Cause	Boiler status / Solution
40	<b>Solar storage tank probe anomaly</b>	If the board detects an anomaly on the solar storage tank probe, the boiler continues to work regularly without the intake of solar energy for heating the DHW as the solar pump stops working.	(1)
41	<b>High temperature on the solar collector</b>	This occurs when the temperature of the solar collector exceeds the maximum limit set.	(1)
42	<b>High temperature on the solar storage tank</b>	This occurs when the temperature of the water in the solar storage tank exceeds the maximum limit set.	(1)
47	<b>Burner power limitation</b>	Should flue high temperature be detected, the boiler reduces power supplied so as not to damage it.	(1)
<p>(1) If the shutdown or fault persists, contact an authorised firm (e.g. Authorised Technical After-Sales Service).</p> <p>(2) Error codes over 31 are not shown on the CAR<sup>V2</sup> and Super CAR display.</p>			

INSTALLER

USER

MAINTENANCE TECHNICIAN

## 2.7 PARAMETERS AND INFORMATION MENU.

By pressing the button “D” it is possible to access a menu divided into three main parts:

- “M1” information
- “M3” customisations
- “M5” configurations: menu reserved to the technician and for which a password is required (See “Maintenance” chapter).
- “M9” settings.

By turning the central heating temperature selector switch (3) scroll through the menu items. By pressing button “D” access the various levels of the menu and the choice of parameters is confirmed. Press button “C” to go back one level.

“M1” information menu. This menu contains the various information relative to boiler functioning:

1st Level	Button	2nd Level	Button	3rd Level	Button	Description	
M1	D ⇨ ⇨ C	P11	D ⇨ ⇨ C			View the management software version of the P.C.B. installed in the boiler	
		P12				View the total functioning hours of the boiler	
		P13				View the number of burner ignitions	
		P14 (with optional external probe present)	D ⇨ ⇨ C		P14/A		View the current external temperature (if optional external probe present)
					P14/B		View the minimum external temperature recorded (if optional external probe present)
					P14/C		View the maximum external temperature recorded (if optional external probe present)
		-- (without external probe (optional)			RESET	D x select ⇨ C	By pressing button "D" the MIN and MAX temperatures measured are reset to zero
		P15	D ⇨ ⇨ C			No display on this boiler model	
		P17				View the speed in instantaneous revs.of the fan	
		P18				View the circulator pump instantaneous speed (in %)	
		P19				View the last 5 events that caused boiler shutdown. Indicator (6) shows the sequential number from 1 to 5 and on indicator (7) the relative error code. By pressing button "D" repeatedly it is possible to view the functioning time and the number of ignitions at which the anomaly occurred	

**Customisations Menu “M3”.** This menu contains all functioning options that can be customised. (The first item of the various options that appears inside the parameter is that selected by default).

If the international language is to be restored (**A1**), proceed as follows:

- press button “D” to access the configuration menu.
- turn selector switch “3” to “PERSONAL”.
- press button “D” to confirm.
- turn selector switch “3” to “DATI”.
- press button “D” to confirm.
- turn selector switch “3” to “LINGUA”.
- press button “D” to confirm.
- turn selector switch “3” to “A1”.
- press button “D” to confirm.

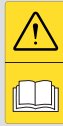

At this point the international items indicated in the menu tables appear on the display.

1st Level	Button	2nd Level	Button	3rd Level	Button	4th Level	Button	Description		
M3	D ⇨ ⇨ C	P31	D ⇨ ⇨ C	AUTO (Default)	D x select  ⇨ C			The display lights up when the burner is ignited and when the controls are accessed, it remains on for 5 seconds after the last operation performed		
				ON				The display is always lit up		
				OFF				The display only lights up when the controls are accessed and remains on for 5 seconds after the last operation performed		
		P32	D ⇨ ⇨ C	P32/B	D ⇨ ⇨ C			ITALIANO  A1 (Default)	D x select  ⇨ C	All descriptions are given in Italian
										All descriptions are given in alpha-numerical format
		P33	D ⇨ ⇨ C		D ⇨ ⇨ C	OFF (Default)	D x select  ⇨ C			In winter mode, by activating this function it is possible to activate the room central heating function even if the eventual Remote Control or TA are out of service.
						ON				
		RESET			D x select  ⇨ C					By pressing button “D” the customisations made are zeroed, restoring factory settings “P31” in “ILL. AUTO” and “P32/B” in “ITALIANO”

**Zone Menu (optional) “M9”.** The “M9” zone menu is only activated if the board detects connection to an additional zone board (optional). This menu contains the temperature settings of additional zones.

1st Level	Button	2nd Level	Button	Description
M9	D ⇨ ⇨ C	P91	D ⇨	It displays the current temperature of mixed zone 2.
			⇨ C	
		P92	D ⇨	It displays the current temperature of mixed zone 3 (Optional).
			⇨ C	
P93	D ⇨	It defines the flow temperature of mixed zone 2. With external probe (Optional) fitted the flow temperature may be corrected with respect to the operation curve set by the external probe. See OFFSET on external probe graph (Fig. 8) changing temperature from -15°C to +15°C.		
	⇨ C			
P94	D x select  ⇨ C	It defines the flow temperature of zone number 3 at low temperature (Optional). With external probe (Optional) fitted the flow temperature may be corrected with respect to the operation curve set by the external probe. See OFFSET on external probe graph (Fig. 8) changing temperature from -15°C to +15°C.		

## 2.8 BOILER SHUTDOWN

Switch the boiler off by pressing the “” button. disconnect the onnipolar switch outside of the boiler and close the gas cock upstream of the appliance. Never leave the boiler switched on if left unused for prolonged periods.

## 2.9 RESTORE CENTRAL HEATING SYSTEM PRESSURE.

Periodically check the system water pressure. The boiler pressure gauge should read a pressure between 1 and 1.2 bar.

*If the pressure falls below 1 bar (when the circuit is cold) restore normal pressure via the relevant cock located to the right of the boiler and accessible from the side door (Fig. 46).*

**N.B.:** close the cock after the operation.

If pressure values reach around 3 bar the safety valve may be activated.

In this case, remove water from a radiator air vent valve until a pressure of 1 bar is achieved, or ask for assistance from professionally qualified personnel.

In the event of frequent pressure drops, contact qualified staff for assistance to eliminate the possible system leakage.

## 2.10 DRAINING THE SYSTEM.

To drain the boiler, use the special draining valve (Fig. 37-38). Before draining, ensure that the filling cock is closed.

### ATTENTION:

**if glycol was input in the system's circuit, make sure it is discharged into the waste water system, pursuant to regulation EN 1717.**



## 2.11 DRAINING THE DOMESTIC HOT WATER CIRCUIT.

To do this, always close the domestic cold water inlet upstream of the appliance.

Open any domestic hot water tap to discharge the pressure from the circuit.

## 2.12 CYLINDER DRAINING.

To drain the storage tank, use the special draining valve (Fig. 37-38).

Before performing this operation, close the boiler cold water inlet valve and open any DHW system hot water valve in order to air into the cylinder.



## 2.13 ANTIFREEZE PROTECTION.

The boiler comes standard with an antifreeze function that activates the pump and burner when the system water temperature in the boiler falls below 4°C.

*The antifreeze function is only guaranteed if:*

- *the boiler is correctly connected to gas and electricity power supply circuits;*
- *the boiler is powered constantly;*
- *the boiler is on and not in stand-by ();*
- *the boiler is not in no ignition block (Par.*
- *the boiler essential components are not faulty.*

In the case of prolonged inactivity (second home), we also recommend to:

- disconnect the electric power supply;
- fully drain the central heating circuit, the boiler domestic hot water circuit and the condensation trap. In systems that are drained frequently, filling must be carried out with suitably treated water to eliminate hardness that can cause lime-scale.

#### 2.14 CASE CLEANING.

Use damp cloths and neutral detergent to clean the boiler casing.  
Never use abrasive or powder detergents.

#### 2.15 DECOMMISSIONING.

In the event of permanent shutdown of the boiler, contact professional staff for the procedures and ensure that the electrical, water and gas supply lines are shut off and disconnected.

INSTALLER

USER

MAINTENANCE TECHNICIAN

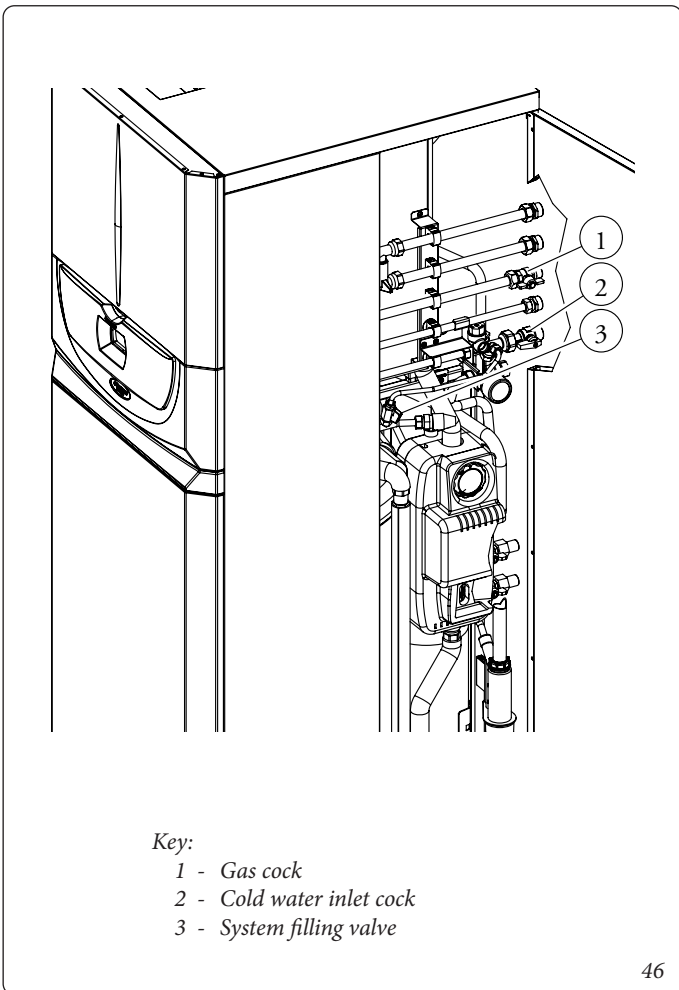

### 3 INSTRUCTIONS FOR MAINTENANCE AND INITIAL CHECK.

#### 3.1 GENERAL WARNINGS.

##### ATTENTION:

operators who install and service the appliance must wear the personal protective equipment (PPE) required by applicable law.



Note: the list of possible PPE is not complete as they are indicated by the employer.

##### ATTENTION:

before performing any maintenance operation, make sure:

- you have disconnected the power to the appliance;
- you have closed the gas cock;
- you have discharged the pressure from the system and domestic hot water circuit.



**Risk of material damage after using sprays and liquids to search for leaks.**

Leak sprays and liquids clog the reference hole PR (Ref. 4 Fig. 49) of the gas valve, damaging it irreparably.

During installation and maintenance, do not use spray or liquids in the upper area of the gas valve (side referring to the electric connections)



##### Supply of spare parts.

The device's warranty shall be rendered null and void if unapproved or unsuitable parts are used for maintenance or repairs. These will also compromise the product's compliance, and the said product may no longer be valid and fail to meet the current regulations.

With regard to the above, only use Immergas original spare parts when replacing parts.



If additional documentation needs to be consulted for extraordinary maintenance, contact the Authorised After-Sales Service.



#### 3.2 INITIAL CHECK.

##### To commission the boiler:



- make sure that the type of gas used corresponds to boiler settings;
- check connection to a 230V-50Hz power mains. correct L-N polarity and the earthing connection;
- make sure the central heating system is filled with water and that the pressure gauge indicates a pressure of 1-1.2 bar.
- check that the the air vent valve cap is open and that the system is well deaerated;
- switch the boiler on and check correct ignition;
- check the  $\Delta p$  gas values in domestic hot water and central heating modes;
- check the CO<sub>2</sub> flow rate in the flue:
  - maximum
  - minimum
 the values must comply with what is indicated in the relative tables (Par. 3.3);
- check activation of the safety device in the event of no gas, as well as the relative activation time;
- check the intervention of the main switch located upstream of the boiler and in the boiler;
- check that the intake and/or exhaust terminals are not blocked;
- ensure activation of all adjustment devices;
- seal the gas flow rate regulation devices (if settings are modified);
- check the production of domestic hot water;
- check sealing efficiency of water circuits;
- check ventilation and/or aeration of the installation room where provided.

**Even if just one single safety check provides a negative result. do not commission the system.**



### 3.3 YEARLY APPLIANCE CHECK AND MAINTENANCE.



The following checks and maintenance should be performed at least once a year to ensure operation, safety and efficiency of the appliance over time.



- Clean the flue side of the heat exchanger.
  - Clean the main burner.
  - Check the correct positioning, integrity and cleanliness of the detection and ignition electrodes; remove any oxide present.
  - If deposits are detected in the combustion chamber they must be removed and the heat exchanger coils must be cleaned using nylon or broomcorn brushes; it is forbidden to use brushes made of metal or other materials that may damage the combustion chamber. It is also forbidden to use alkaline or acid detergents.
  - Check the integrity of the insulating panels inside the combustion chamber and if damaged replace them.
  - Visually check for water leaks or oxidation from/on fittings and traces of condensate residues inside the sealed chamber.
  - Check contents of the condensate drain trap.
  - Via the condensate drain cap check that there are no residues of material that clog condensate passage; also check that the entire condensate drain circuit is clear and efficient.
- In the event of obstructions (dirt, sediment, etc.) with consequent leakage of condensate in the combustion chamber, one must replace the insulating panels.
- Check that the burner seal gaskets and the lid are intact and perfectly efficient, otherwise replace them. In any case the gaskets must be replaced at least every two years, regardless of their state of wear.
  - Check that the burner is intact, that it has no deformations or cuts and that it is properly fixed to the combustion chamber lid; otherwise it must be replaced.
  - Visually check that the water safety valves drain is not blocked.
  - Check, after discharging the system pressure and bringing it to zero (read on boiler pressure gauge), that the expansion vessel charge is at 1.0 bar.
  - Check that the domestic hot water expansion vessel charge is at a pressure between 2.2 and 2.8 bar.
  - Check the charge of the solar DHW expansion vessel according to system requirements.
  - Check that the system static pressure (with system cold and after refilling the system by means of the filling cock) is between 1 and 1.2 bar.
  - Visually check that the safety and control devices have not been tampered with and/or shorted, in particular:
    - temperature safety thermostat;
    - system pressure switch.
  - Check integrity of the boiler Magnesium anode.

- Check the condition and integrity of the electrical system and in particular:



- supply voltage cables must be inside the fairleads;
- there must be no traces of blackening or burning.
- Check the cleanliness of the solar collector glass.
- Check the status of the glycol present in the solar circuit.
- Control the heat carrying liquid every 2 years for its antifreeze capacity and pH value.
- Check ignition and operation.
- Check correct calibration of the burner in domestic hot water and central heating phases.
- Check the operation of the appliance control and adjustment devices and in particular:
  - system control thermostat intervention;
  - domestic hot water control thermostat intervention.
- Check sealing efficiency of the gas circuit and the internal system.
- Check the intervention of the device against no gas ionisation flame control. The relative intervention time must be less than 10 seconds.

Hercules Solar 26 2 ErP		
	CO <sub>2</sub> at nominal output	CO <sub>2</sub> at minimum output
G 20	9.50% ± 0.5	8.60% ± 0.5
G 31	10.50% ± 0.5	9.60% ± 0.5

In addition to yearly maintenance, one must also check the thermal system, with frequency and procedures that comply with the indications of the technical regulations in force.



INSTALLER

USER

MAINTENANCE TECHNICIAN

### 3.4 PLUMBING DIAGRAM.

INSTALLER

USER

MAINTENANCE TECHNICIAN

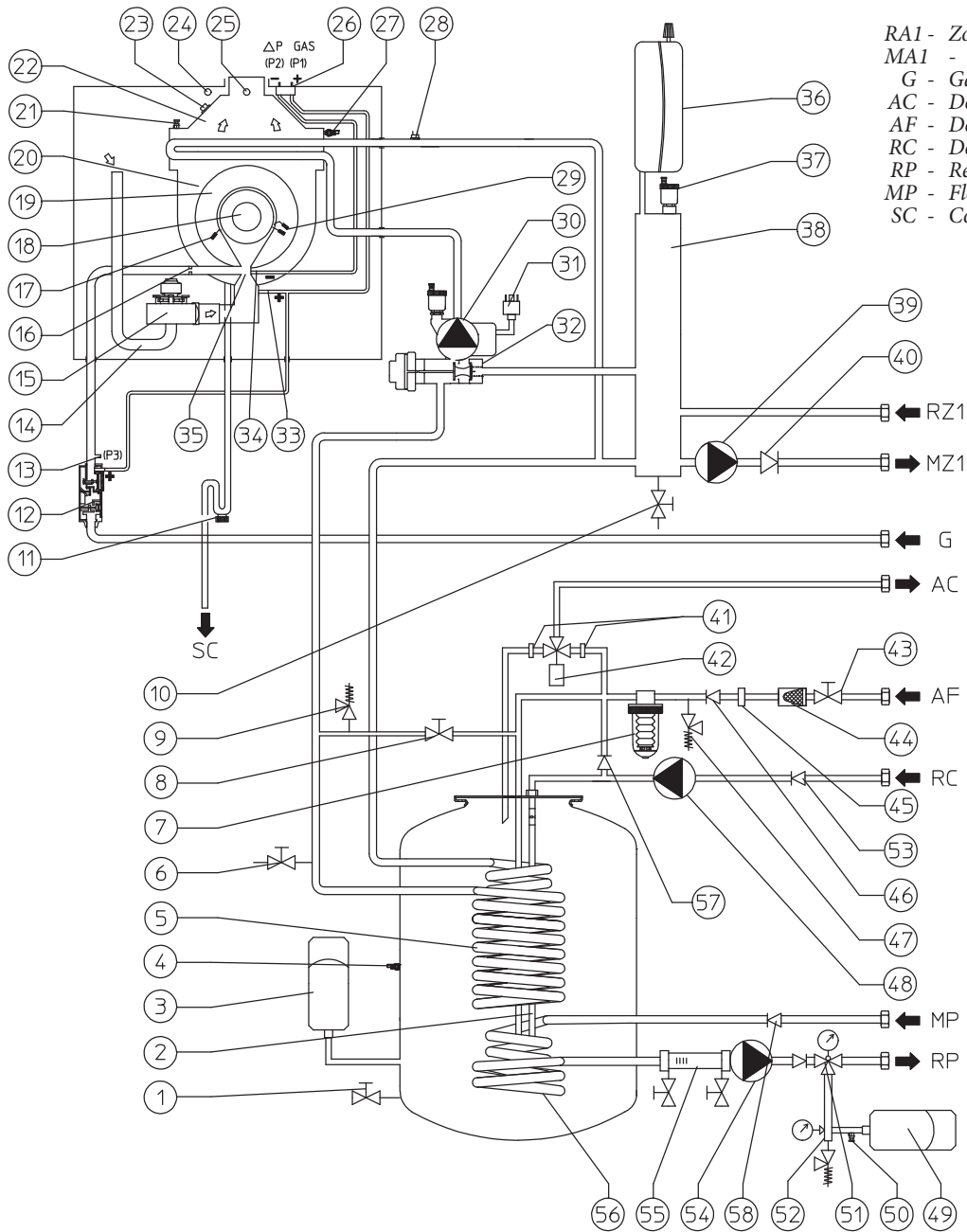

- RA1 - Zone 1 system return (High temperature)
- MA1 - Zone 1 system flow (High temperature)
- G - Gas supply
- AC - Domestic hot water outlet
- AF - Domestic cold water inlet
- RC - Domestic hot water recirculation
- RP - Return from solar panels
- MP - Flow from solar panels
- SC - Condensate drain

#### Key

- |   |  |  |
|---|--|--|
| 1 - Storage tank unit draining valve      | 21 - Manual air vent valve             | 41 - Mixing valve filter               |
| 2 - Magnesium anode                       | 22 - Fumes hood                        | 42 - DHW mixing valve                  |
| 3 - D.H.W. expansion vessel               | 23 - Flue probe                        | 43 - Cold water inlet cock             |
| 4 - Domestic hot water probe              | 24 - Air sample point                  | 44 - Cold water filter                 |
| 5 - Stainless steel coil for storage tank | 25 - Flue sample point                 | 45 - Flow limiter                      |
| 6 - System draining valve                 | 26 - Gas ΔP pressure point             | 46 - Cold water inlet non-return valve |
| 7 - Polyphosphate dispenser (optional)    | 27 - Flow probe                        | 47 - 8 bar safety valve                |
| 8 - System filling valve                  | 28 - Safety thermostat                 | 48 - DHW recirculation pump (optional) |
| 9 - 3 bar safety valve                    | 29 - Ignition electrode                | 49 - Solar expansion vessel            |
| 10 - Manifold draining valve              | 30 - Boiler Circulator                 | 50 - Manual air vent valve             |
| 11 - Condensate drain trap                | 31 - System pressure switch (absolute) | 51 - Shut-off valve with thermometer   |
| 12 - Gas valve                            | 32 - Three-way valve (motorised)       | 52 - Safety valve with manometer       |
| 13 - Gas valve outlet pressure point (P3) | 33 - Venturi positive sign P1          | 53 - One-way valve                     |
| 14 - Air intake pipe                      | 34 - Venturi negative signal P2        | 54 - Solar pump                        |
| 15 - Fan                                  | 35 - Air/gas Venturi manifold          | 55 - Flow meter                        |
| 16 - Gas nozzle                           | 36 - System expansion vessel           | 56 - Solar stainless steel coil        |
| 17 - Detection electrode                  | 37 - Vent valve                        | 57 - One-way valve                     |
| 18 - Burner                               | 38 - Hydraulic manifold                | 58 - One-way solar valve               |
| 19 - Condensation module covers           | 39 - Zone 1 pump                       |  |
| 20 - Condensation module                  | 40 - Zone 1 one-way valve              |  |

### 3.5 WIRING DIAGRAM.

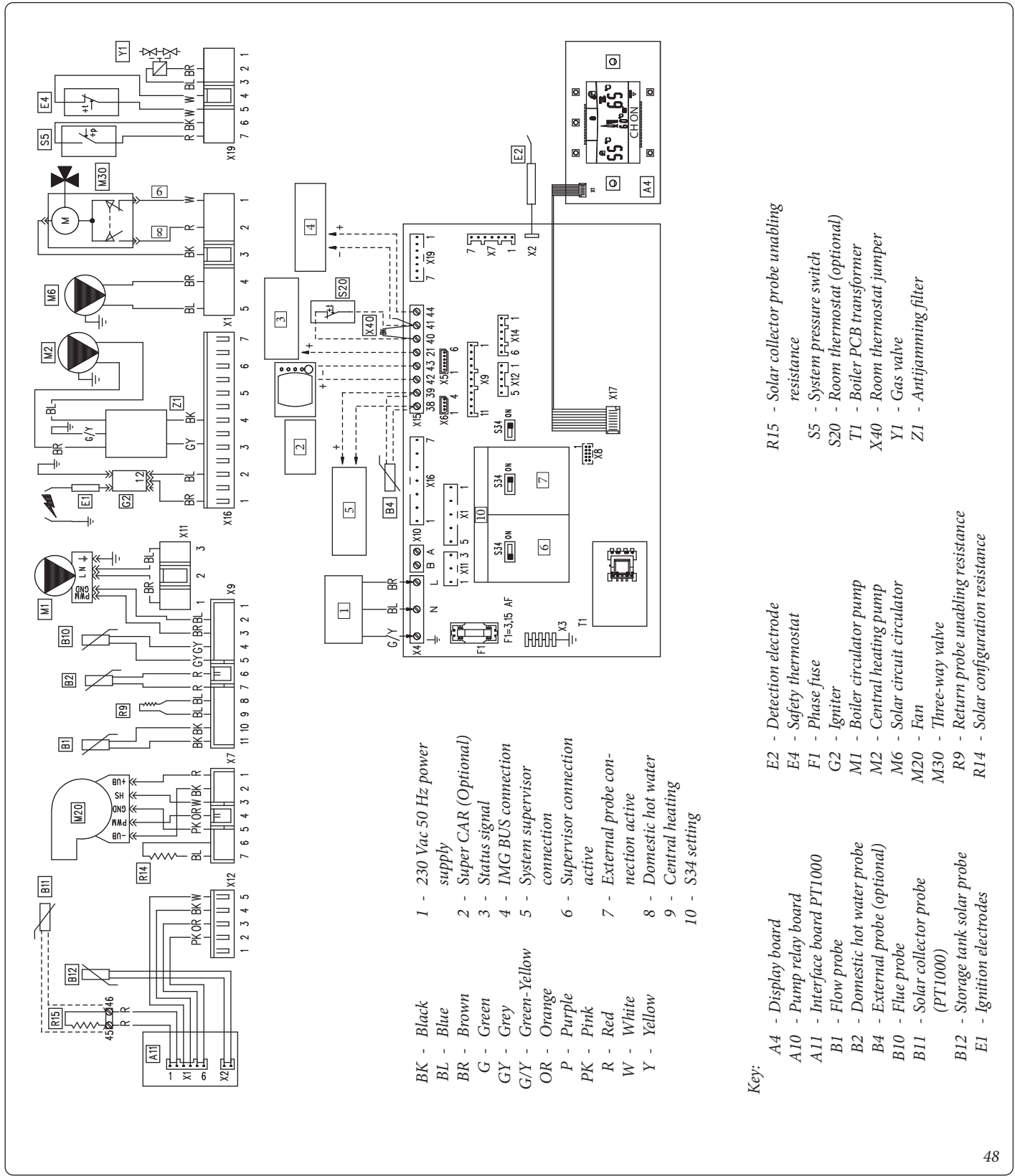

Remote controls: the boiler is designed for use with the Comando Amico Remoto remote control <sup>v2</sup> (CAR<sup>v2</sup>) or alternatively the Super Comando Amico Remoto remote control, which must be connected to clamps 42 and 43 of connector X15 on the P.C.B., observing polarity and eliminating jumper X40.

Room thermostat: the boiler is designed for the application of the Room Thermostat (S20). Connect it to clamps 40 – 41 eliminating jumper X40.

The connector X5 is used for the connection to the relay board.

The connector X6 is for connection to a personal computer.

The connector X8 is used for software updating operations.

Solar collector probe: the boiler is set-up for the connection to a solar panel system; the probe must be connected to clamps 45 and 46, eliminating resistance R15.

INSTALLER

USER

MAINTENANCE TECHNICIAN

### 3.6 TROUBLESHOOTING.

Maintenance operations must be carried out by an authorised company (for example contact the Authorised Technical Service Centre).



#### Red pump LED

There can be three possible causes for this anomaly:

- **Low power supply voltage.** After about 2 seconds, the LED switches from green to red and the pump stops). Wait for the power supply voltage to rise; when the pump restarts, the LED will turn green again with a delay of about one second. Note: The flow rate decreases as the supply voltage decreases.
- **Rotor seized** (Powering the pump with the rotor seized, after about 4 seconds the LED switches from green to red). Carefully act on the screw in the middle of the head to manually release the crankshaft; circulation starts up immediately after the rotor is released and the LED switches from red to green after about 10 seconds.
- **Electrical error.** Check that there is no fault on the pump (on its wiring or electronics).
- **Smell of gas.** Caused by leakage from gas circuit pipelines. Check sealing efficiency of gas intake circuit.
- **Repeated ignition blocks.** No gas, check the presence of pressure in the network and that the gas adduction cock is open.
- **Incorrect adjustment of the gas cock,** check the correct calibration of the gas valve.
- **Irregular combustion or noisiness.** It may be caused by: a dirty burner, incorrect combustion parameters, intake-exhaust terminal not correctly installed. Clean the above components and ensure correct installation of the terminal, check correct setting of the gas valve (Off-Set setting) and correct percentage of CO<sub>2</sub> in flue gas.
- **Frequent interventions of the overheating safety thermostat.** It can depend on the lack of water in the boiler, little water circulation in the system or blocked pump (see Par. 1.28). Check on the manometer that the system pressure is within established limits. Check that the radiator valves are not closed and also the functionality of the pump.
- **Drain trap clogged.** This may be caused by dirt or combustion products deposited inside. Check, by means of the condensate drain cap, that there are no residues of material blocking the flow of condensate.
- **Heat exchanger clogged.** This may be caused by the drain trap being blocked. Check, by means of the condensate drain cap, that there are no residues of material blocking the flow of condensate.
- **Noise due to air in the system.** Check opening of the special air vent valve cap (Part. 39 Fig. 38). Make sure the system pressure and expansion vessel pre-charge values are within the set limits; The factory-set pressure values of the expansion vessel must be 1.0 bar. the value of system pressure must be between 1 and 1.2 bar. Check that system filling and air bleeding has been performed according to the requirements.
- **Noise due to air inside the condensation module.** Use the manual air vent valve (Part. 32 Fig. 38) to eliminate any air present in the condensation module. When the operation has been performed, close the manual vent valve.

#### Gas Valve 848

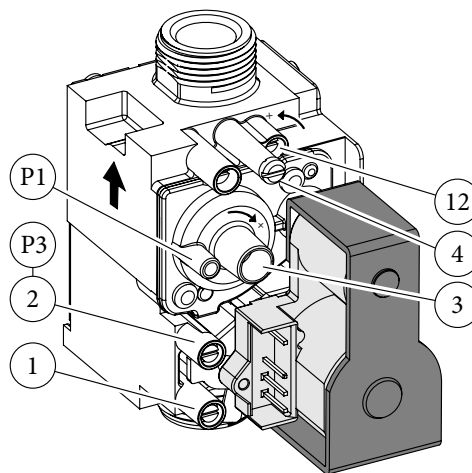

Key:

- 1 - Gas valve inlet pressure point
- 2 - Gas valve outlet pressure point
- 3 - Off/Set adjustment screw
- 4 - Pressure regulator connection (PR)
- 12 - Outlet gas flow rate regulator

49

#### P.C.B.

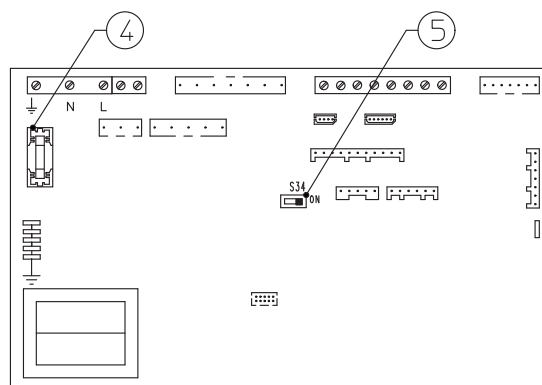

Key:

- 4 - Fuse 3.15 AF
- 5 - S34 Selector:  
On = external probe;  
Off = system supervisor

50

- **Domestic hot water probe faulty.** In order to replace the DHW probe, the storage tank does not have to be emptied as the probe is not in direct contact with the DHW inside the storage tank.

### 3.7 CONVERTING THE BOILER TO OTHER TYPES OF GAS.

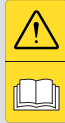

If the boiler has to be converted to a different gas type to that specified on the data nameplate, request the relative conversion kit for quick and easy conversion. The gas conversion operation must be carried out by an authorised company (e.g. Authorised After-Sales Technical Assistance Service).

To convert to another type of gas the following operations are required:

- disconnect the appliance;
  - replace the nozzle located between the gas pipe and gas/air mixing sleeve (Part. 16 Fig. 38), taking care to remove the voltage from the appliance during this operation;
  - re-power the appliance;
  - calibrate the number of fan revolutions (Parag. 3.8);
  - adjust the correct CO2 value (Par. 3.9);
  - seal the gas flow rate regulation devices (if settings are modified);
  - after completing the conversion, apply the sticker, contained in the conversion kit, near the data nameplate. Using an indelible marker pen, delete the data relative to the old type of gas.
- These adjustments must be made with reference to the type of gas used, following that given in the table (Par. 4.2).

### 3.8 CALIBRATION OF NUMBER OF FAN REVS.

**Attention:** Verification and calibration is necessary, in the case of transformation to other types of gas, in the extraordinary maintenance phase with replacement of the PCB air/gas circuit components or in the case of installations with fume extraction systems, with horizontal concentric pipe measuring more than 1 metre.

The boiler heat output is correlated to the length of the air intake and flue exhaust pipes. This decreases with the increase of pipe length. The boiler leaves the factory adjusted for minimum pipe length (1m). It is therefore necessary, especially in the case of maximum pipe extension, to check the  $\Delta p$  gas values after at least 5 minutes of the burner operating at nominal heat output, when the temperatures of the intake air and exhaust flue gas have stabilised. Adjust the nominal and minimum heat output in the domestic hot water and central heating modes according to the values in the table (Par. 4.1) using the differential manometers connected to the  $\Delta p$  gas pressure points (36 and 37 Fig. 38).

Access the configurations menu (M5) under the “SERVICE” item and adjust the following parameters (Par. 3.11):

- boiler maximum heat output “P62”;
- boiler minimum heat output “P63”;
- maximum central heating output “P64”;
- minimum central heating output “P65”;

Below find the default settings present on the boiler:

Hercules Solar 26 2 ErP		
P62	G20: 5580 (rpm)	GPL: 5580 (rpm)
P63	G20: 1020 (rpm)	GPL: 1020 (rpm)
P64	G20: 5100 (rpm)	GPL: 5040 (rpm)
P65	G20: 1020 (rpm)	GPL: 1020 (rpm)

### 3.9 CO<sub>2</sub> ADJUSTMENT.

#### Calibration of the minimum CO<sub>2</sub> (minimum central heating power).

Enter the chimney sweep phase without withdrawing domestic hot water and take the selector switches to minimum (turn them in an anti-clockwise direction until "0" is seen on the display). To have an exact value of CO<sub>2</sub> in the flue gas the technician must insert the sampling probe to the bottom of the sample point, then check that the CO<sub>2</sub> value is that specified in the table (Par. 4.2), otherwise adjust the screw (3 Fig. 49) (Off-Set adjuster). To increase the CO<sub>2</sub> value, turn the adjustment screw (3) in a clockwise direction and vice versa to decrease it.

#### Calibration of the maximum CO<sub>2</sub> (nominal central heating power).

On completion of the adjustment of the minimum CO<sub>2</sub> keeping the chimney sweep function active, take the heating selector switch to maximum (turn it in a clockwise direction until "99" is seen on the display). To have an exact value of CO<sub>2</sub> in the flue gas the technician must insert the sampling probe to the bottom of the sample point, then check that the CO<sub>2</sub> value is that specified in the table (Par. 4.2), otherwise adjust the screw (12 Fig. 49) (gas flow rate regulator).

To increase the CO<sub>2</sub> value, turn the adjustment screw (12) in an anti-clockwise direction and vice versa to decrease it.

At every adjustment variation on the screw 12 it is necessary to wait for the boiler to stabilise itself at the value set (about 30 sec.).

### 3.10 CHECKS FOLLOWING CONVERSION TO ANOTHER TYPE OF GAS.

After making sure that conversion was carried out with a nozzle of suitable diameter for the type of gas used and the settings are made at the correct pressure, check that the burner flame is not too high or low and is stable (does not detach from burner);

All boiler adjustment operations must be carried out by a qualified company (e.g. Authorised After-Sales Assistance).



### 3.11 PROGRAMMING THE P.C.B.

The boiler is prepared for possible programming of several operation parameters. By modifying these parameters as described below, the boiler can be adapted according to specific needs.

If the international language is to be restored (A1), see the indications described in Par. 2.8 (Customisations menu - M3).



By pressing the button "D" it is possible to access the main menu, divided into three main parts:

- Information "M1" (See "User" Chapter)
- customisations "M3" (See "User" Chapter)
- "M5" configurations, menu reserved for the technician and for which a password is required.

To access programming, press button "D", turn the heating temperature selector switch (3) and scroll through the menu items until reaching "M5", press button "D", enter the password and set the parameters according to requirements.

Listed below are the items in the "M5" menu with default parameters and possible options indicated.

By turning the central heating temperature selector switch (3) scroll through the menu items. By pressing button "D" access the various levels of the menu and the choice of parameters is confirmed. Press button "C" to go back one level.

(The first item of the various options that appears inside the parameter is that selected by default).

M5 menu  
(password must be entered)

1st Level	2nd Level	Options	Description	Default value	Value set by the technician
P50		25 ÷ 50	Set the boiler power in the ignition stage. The value is in percentage with respect to parameter P62	(See par. 3.8)	
P53		P53 1	Identifies the power of the boiler on which the P.C.B. is installed P53 1 = Not used P53 2 = 26 kW P53 3 = 32 kW	Equal to boiler power	Equal to boiler power
		P53 2			
		P53 3			
P54		P54 1	Displays the temperature measured by the probe in the top part of the storage tank unit	-	-
		P54 2	Displays the temperature measured by the probe in the bottom part of the storage tank unit (controlled by the solar circuit)	-	-
		P54 3	The value displayed does not affect this model	-	-
		P54 4	Displays the temperature measured by the probe on the solar collector	-	-
P55			Displays the central heating flow temperature at which the boiler functions, calculated by the controls active on the system heat adjustment	-	-
SERVICE	P57	AUTO	- DELTA T = 0:proportional head (see parag. 1.28) - DELTA T = 5 ÷ 25 K: constant ΔT (see par. 1.28) <b>Note:</b> after selecting DELTA T adequate to the requirements, maximum (Vmax) and minimum (Vmin) circulating pump speed may be selected (adjustable from 100% to 75%).	AUTO 0	
		FIX	Fixed circulator pump speed (adjustable between 100% and 75%)		
	P62	4000 ÷ 5900	Set the maximum output depending on the domestic hot water, setting the speed of the fan (in RPM)	(See par. 3.8)	
	P63	900 ÷ 1500	Set the minimum output depending on the domestic hot water, setting the speed of the fan (in RPM)	(See par. 3.8)	
	P64	≤ P62	Set the maximum output depending on room heating. The value must be less than or equal to P62	(See par. 3.8)	
	P65	≥ P63	Set the minimum output according to room heating. The value must be greater than or equal to P63	(See par. 3.8)	
	P66	P66/A	Without the external probe (optional) it defines the minimum flow temperature. With the external probe present it defines the minimum flow temperature corresponding to operation with maximum external temperature (see graph Fig. 8) (it can be set between 20°C and 50°C) <b>N.B.:</b> to continue one must confirm the parameter (press “D” or exit adjustment “P66” by pressing “C”)	20°C	
		P66/B	Without the external probe (optional) it defines the maximum flow temperature. With the external probe present it defines the maximum flow temperature corresponding to operation with minimum external temperature (see graph Fig. 8) (it can be set between 50°C and 85°C) <b>N.B.:</b> to continue one must confirm the parameter (press “D” or exit adjustment “P66” by pressing “C”)	85°C	

INSTALLER

USER

MAINTENANCE TECHNICIAN

M5 menu (password must be entered)					
1st Level	2nd Level	Options	Description	Default value	Value set by the technician
SERVICE	P66	P66/C	With the external probe present it defines at which minimum external temperature the boiler must operate at the maximum flow temperature (see graph Fig. 8) (can be set between -20°C and 0°C) <b>N.B.:</b> to continue one must confirm the parameter (press "D" or exit adjustment "P66" by pressing "C")	-5°C	
		P66/D	With the external probe present it defines at which maximum external temperature the boiler must operate at the minimum flow temperature (see graph Fig. 8) (can be set between 5°C and +25°C) <b>N.B.:</b> to continue one must confirm the parameter (press "D" or exit adjustment "P66" by pressing "C")	25°C	
	P67	P67.1	In winter mode the pump is always powered and so functions continuously	P67.2	
		P67.2	In winter mode the pump is managed by the room thermostat or by the remote control		
		P67.3	In winter mode the pump is managed by the room thermostat or by the remote control and by the boiler flow probe		
	P68	0s ÷ 500s	The boiler is set to ignite the burner immediately after a request for central heating. In the case of particular systems (e.g. area systems with motorised thermostatic valves etc.) it could be necessary to delay switch-on	0 seconds	
	P69	0s ÷ 255s	The boiler has an electronic timing device that prevents the burner from igniting too often in the central heating phase.	180 seconds	
	P70	0s ÷ 840s	The boiler performs an ignition ramp to arrive from minimum power to nominal heat output.	180 seconds (3 minutes)	
	P71	P71.1	OFF domestic hot water "correlated" to the switch-off of the boiler takes place on the basis of the temperature set using the domestic hot water adjustment selector switch. Solar function active, if the input domestic hot water has a sufficient temperature the boiler does not switch on	P71.1	
		P71.2	"fixed" domestic hot water OFF; the boiler switches off at 65°C. Solar function deactivated		
	P72	AUTO OFF 09 L/M 12 L/M 15 L/M	The boiler allows to set the flow rate adjuster on the various levels. Auto (automatic functioning, therefore with variable flow rate) Open (adjuster completely open therefore maximum flow rate available) 09 L/M, 12 L/M and 15 L/M (operation with defined flow)	AUTO	
	RELE1 (optional)	RELE1-0	Relay 1 not used	RELE1-1	
		RELE1-1	In a system divided into zones, relay 1 controls the main zone		
		RELE1-2	The relay signals the intervention of a boiler block (Can be coupled to an external signalling device, not supplied)		
		RELE1-3	The relay signals that the boiler is on and in the heating stage (Can be coupled with an external circulator pump, not supplied)		
RELE1-4		Controls the opening of an external gas valve in concomitance with an ignition request of the boiler burner			
RELE1-5		In the event the boiler circulator pump is replaced with a traditional fixed speed circulator pump one must connect the new circulator pump to the relay board.			



M5 menu (password must be entered)					
1st Level	2nd Level	Options	Description	Default value	Value set by the technician
SERVICE	RELE2 (optional)	RELE2-0	Relay 2 not used	RELE2-0	
		RELE2-1	In a system divided into zones, relay 2 controls the secondary zone		
		RELE2-2	The relay signals the intervention of a boiler block (Can be coupled to an external signalling device. not supplied)		
		RELE2-3	The relay signals that the boiler is on and in the heating stage (Can be coupled with an external circulator pump, not supplied)		
		RELE2-4	Controls the opening of an external gas valve in concomitance with an ignition request of the boiler burner		
		RELE2-5	Function not available in this boiler model		
		RELE2-6	In the event the boiler circulator pump is replaced with a traditional fixed speed circulator pump one must connect the new circulator pump to the relay board.		

M5 menu (password must be entered)					
1st Level	2nd Level	Options	Description	Default value	Value set by the technician
	RELE3 (optional)	RELE3-0	Relay 3 not used	RELE3-0	
		RELE3-1	Check the storage tank recirculation pump (not used on this model)		
		RELE3-2	The relay signals the intervention of a boiler block (Can be coupled to an external signalling device. not supplied)		
		RELE3-3	The relay signals that the boiler is on and in the heating stage (Can be coupled with an external circulator pump, not supplied)		
		RELE3-4	Controls the opening of an external gas valve in concomitance with an ignition request of the boiler burner		
		RELE3-5	Function not available in this boiler model		
		RELE3-6	In the event the boiler circulator pump is replaced with a traditional fixed speed circulator pump one must connect the new circulator pump to the relay board		
	P76	-15°C ÷ +14°C CE	With S34 = On. If the reading of the external probe is not correct it is possible to correct it in order to compensate any environmental factors With S34 = Off and system supervisor connected set the parameter to maximum until CE value is displayed	0°C	
SOLAR	PAR 1	0 ÷ 3	Solar operating mode. 0 = Disabled 1 = Solar active with automatic pump 2 = Solar active with continuous pump 3 = Solar active with automatic pump (CH integration cannot be activated on this boiler)	1	
	PAR 2	ΔT 1 ÷ 20K	Enabling differential. Collector pump.	6	
	PAR 3	ΔT 1 ÷ 20K	Disabling differential. Collector pump.	4	
	PAR 4	0 ÷ 1	Antifreeze function. 0 = Deactivated 1 = Active	0	
	PAR 5	100°C ÷ 200°C	Maximum temperature accepted by the collector	140	
	PAR 6	60°C ÷ 95°C	Maximum temperature accepted by the storage tank	80	
	PAR 7	10°C ÷ 90°C	Minimum temperature accepted by the collector	35	

INSTALLER

USER

MAINTENANCE TECHNICIAN

### 3.12 “CHIMNEY SWEEP FUNCTION”

If this function is activated it takes boiler functioning to the adjustable power of the central heating selector switch. In this state all adjustments are excluded and only the safety thermostat and the limit thermostat remain active. To activate the chimney sweep function press the Reset button “C” for 8 to 15 seconds in absence of domestic hot water and heating requests. Its activation is signalled by the relative symbol (22 Fig. 39). This function allows the technician to check the combustion parameters. After the checks deactivate the function, switching the boiler off and then on again using the Stand-by button.

### 3.13 PUMP ANTI-BLOCK FUNCTION.

The boiler has a function that starts the pump at least once every 24 hours for the duration of 30 seconds in order to reduce the risk of the pump becoming blocked due to prolonged inactivity.

### 3.14 THREE-WAY ANTI-BLOCK FUNCTION.

Both in “domestic hot water” and in “domestic hot water-central heating” phase the boiler is equipped with a function that starts the three-way motorised group 24 hours after it was last in operation, running it for a full cycle so as to reduce the risk of the three-way group becoming blocked due to prolonged inactivity.

### 3.15 RADIATORS ANTIFREEZE FUNCTION.

If the system return water is close to freezing, the boiler starts up until it reaches a safety temperature.

### 3.16 P.C.B. PERIODIC SELF-CHECK.

During functioning in central heating mode or with boiler in standby, the function activates every 18 hours after the last boiler check/power supply. In case of functioning in domestic hot water mode the self-check starts within 10 minutes after the end of the withdrawing in progress, for duration of approx. 10 seconds.

#### ATTENTION:

during self-check, the boiler remains off.



### 3.17 AUTOMATIC VENT FUNCTION.

In the case of new central heating systems and in particular mode for floor systems, it is very important that deaeration is performed correctly. To activate function “F8” press buttons “A and B” at the same time (Fig. 39) for 5 seconds with the boiler in stand-by. The function consists of the cyclic activation of the pump (100 s ON. 20 s OFF) and the 3-way valve (120 s domestic hot water. 120 s central heating). The function ends after 18 hours or by switching the boiler on using the ignition button “⏻”.

### 3.18 CASING REMOVAL.

To facilitate boiler maintenance the casing can be completely removed as follows:

- Control panel opening (1) (Fig. 51 and 52).
  - Open the door (2) by pressing it in the centre to make it swing.
  - Remove the rubber protection caps (3) and loosen the two screws (4).
  - Disassemble the upper front (5) pushing it upwards in order to free it from the fixing slots and pulling it towards yourself (detail A).
  - Lift the control panel, gripping it at the sides to make it exit from the fixing pins (6).
  - After which, pull the control panel towards yourself and turn it as shown in the figure.
- Right side door disassembly (Fig. 53).
  - Open the door (7) making it turn by at least 90° outwards.
  - Remove the screw (8) in the top corner of the door (7).
  - Release the door (7) from the bracket just released from the screw (8) bending it outwards and sliding it off of the lower pin (9).
- Lower front panel disassembly (10) (Fig. 54).
  - undo the front screws (11), push the front slightly upwards (10) in order to free it from the lower fixing slots and pull it towards yourself (detail B);
- Disassembly of the lids (12, 14) (Fig. 54).
  - remove the front half-cover (12) loosening the internal screws (13), pull the cover towards yourself to release it from the 3 screws with end stop positioned in the rear (Part. C) and then lift the lid.
  - remove the rear half-cover (14) (not indispensable) by loosening the two screws (15).
- Right side disassembly (16) (Fig. 54).
  - remove the right side (16) loosening the three screws (17) present and then lightly push upwards in a way to release the side from its seat and pull it outwards (part. D).
- Disassembly of the left sides (17, 19) (Fig. 55).
  - remove the upper side (17) loosening the two screws (18) present and then lightly push the side upwards in a way to release the side from its seat and pull it outwards (part. E).
  - remove the lower side (19) loosening the two screws (18) present and then lightly push the side upwards in a way to release the side from its seat and pull it outwards (part. E).

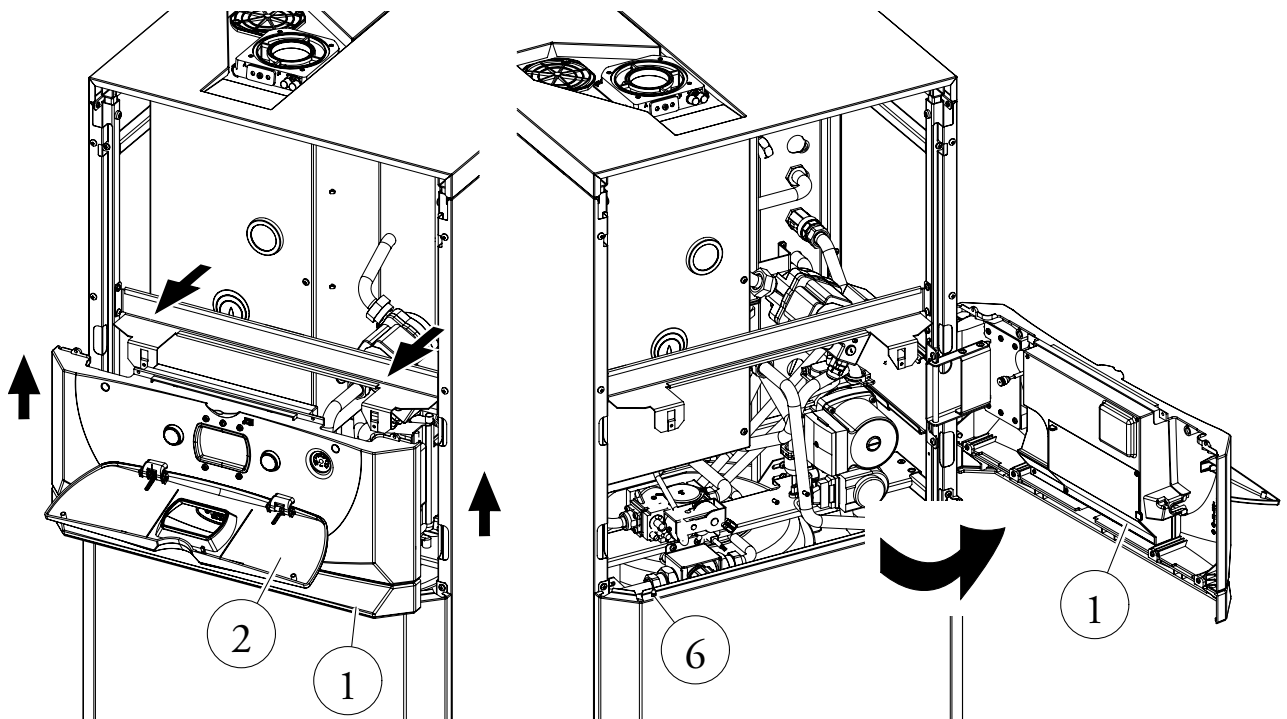
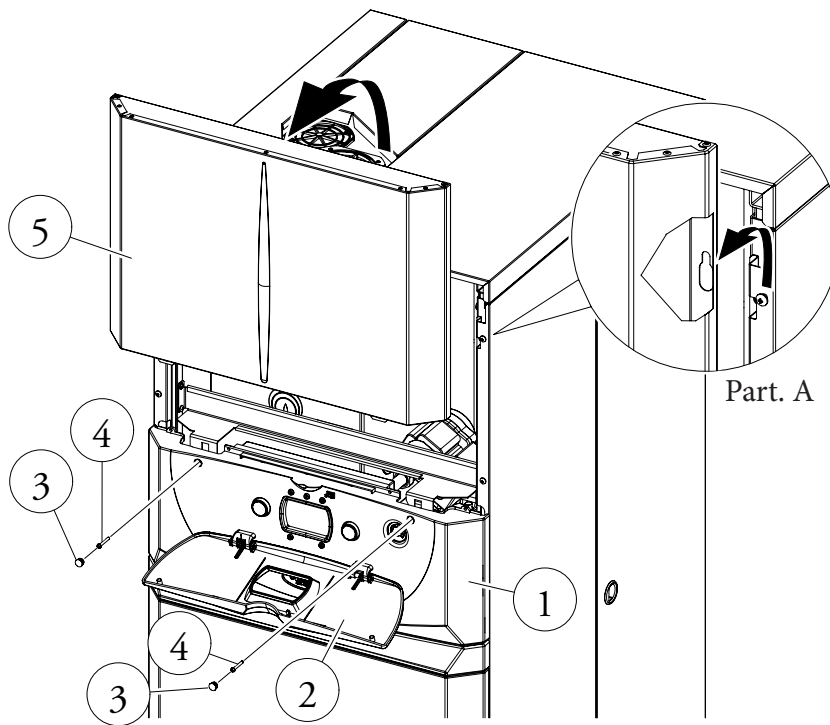

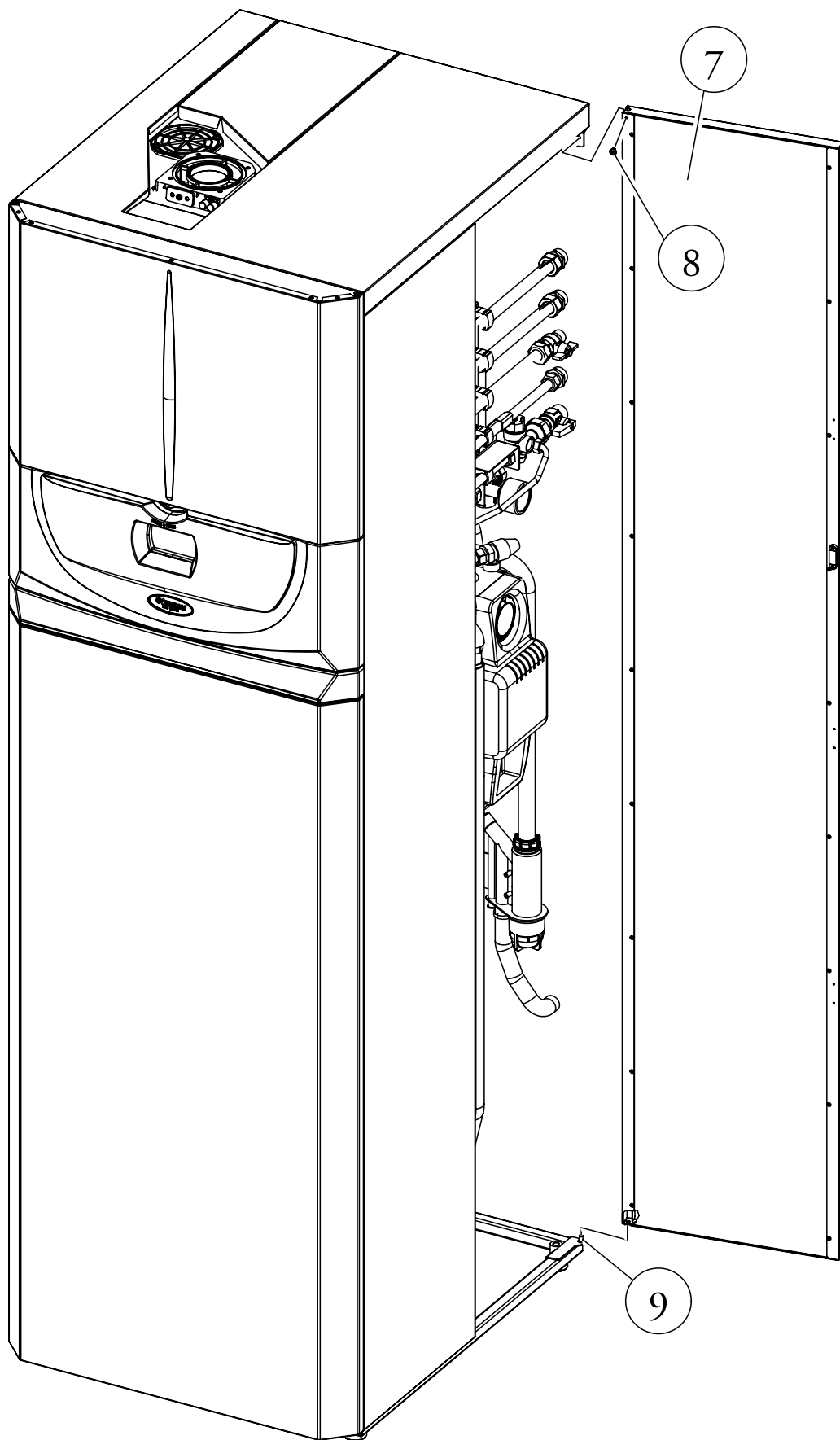

INSTALLER

USER

**MAINTENANCE TECHNICIAN**

INSTALLER

USER

MAINTENANCE TECHNICIAN

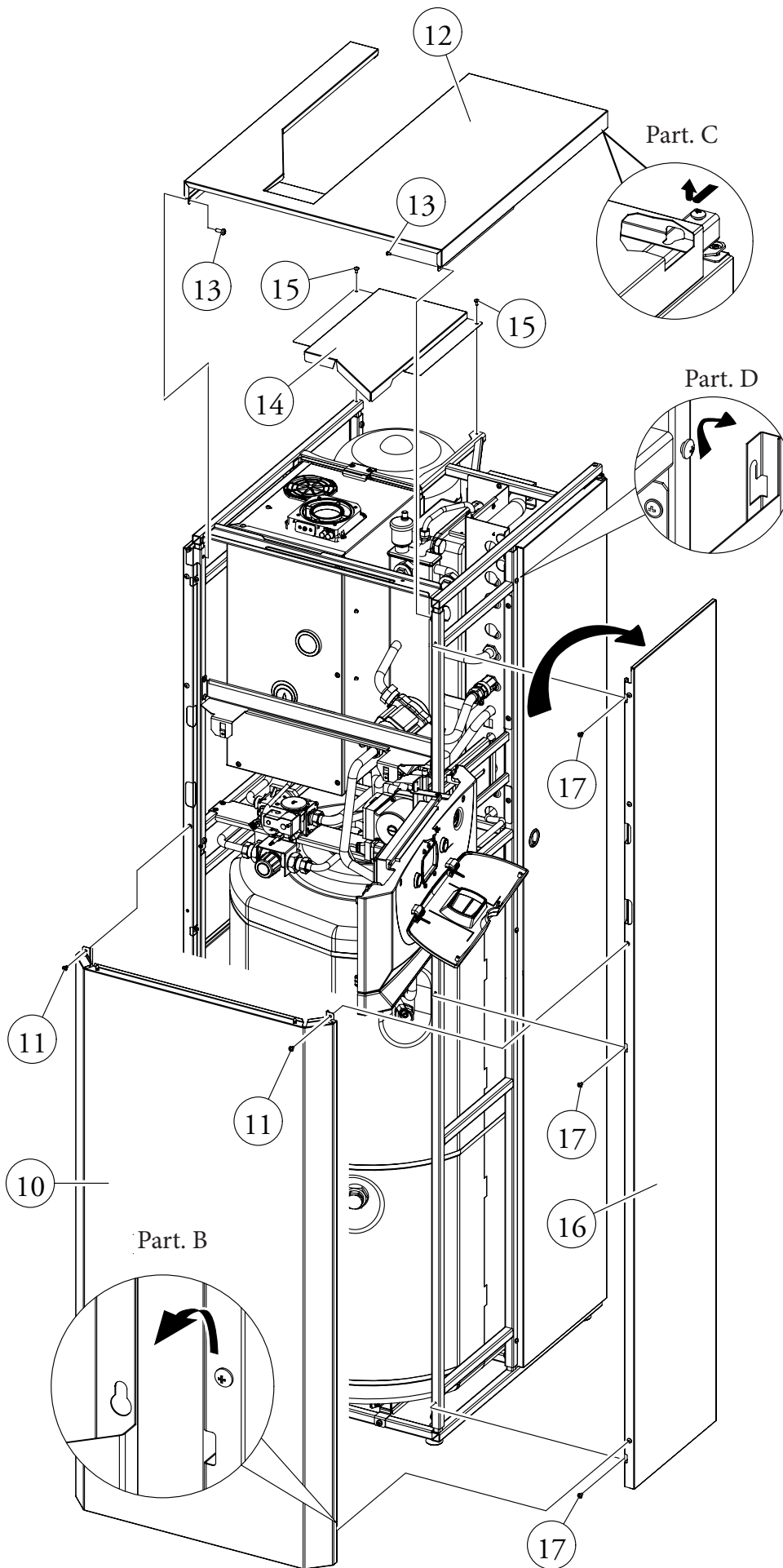

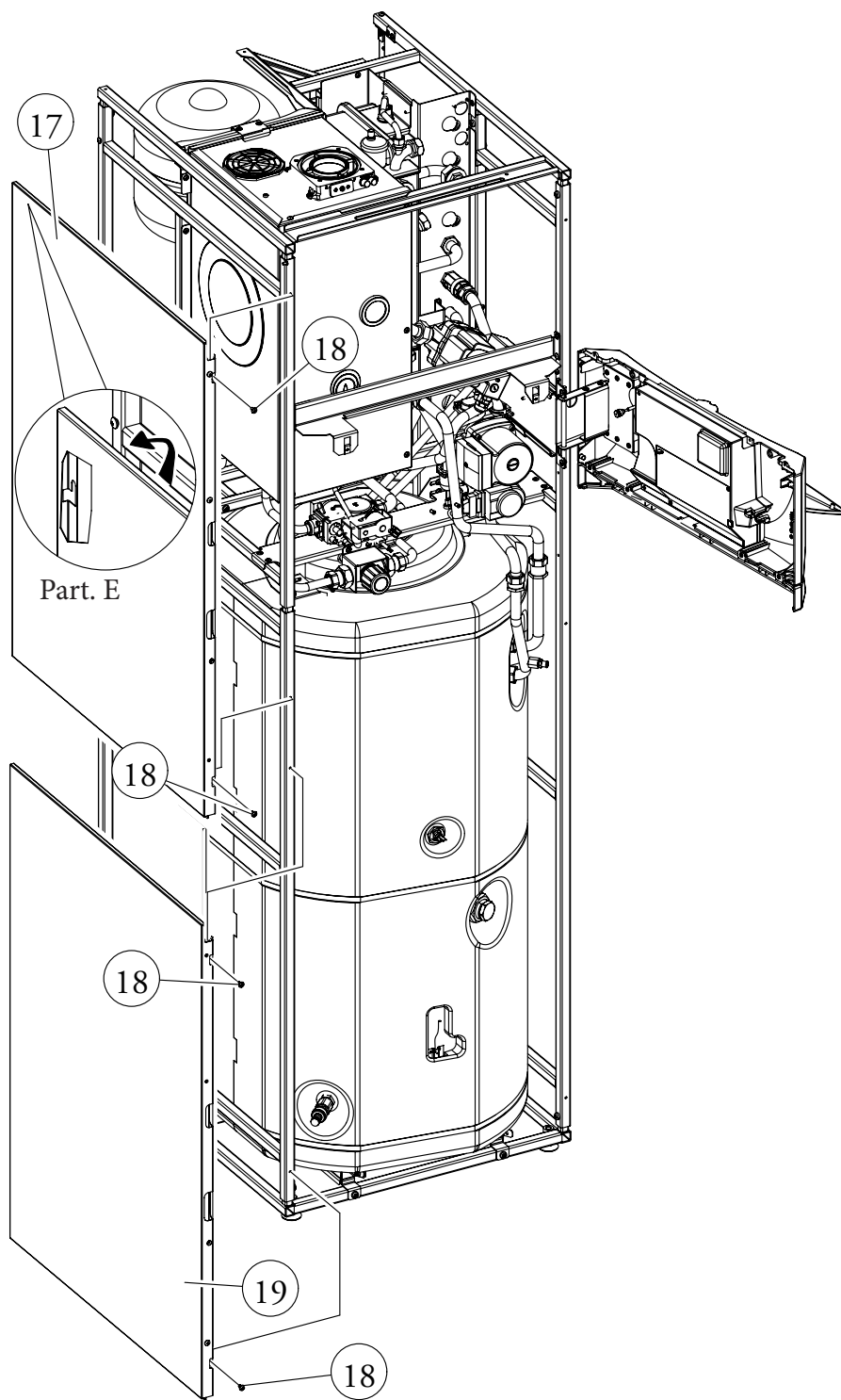

INSTALLER

USER

MAINTENANCE TECHNICIAN

# 4 TECHNICAL DATA.

## 4.1 VARIABLE HEAT OUTPUT.

N.B.: the pressures indicated in the table represent the differences of pressures at the ends of the Venturi mixer and can be measured from the pressure points in the upper part of the sealed chamber (see pressure test 36 and 37 Fig. 38). The adjustments must be made

with a digital differential pressure gauge with scale in tenths of a mm or Pascal. The power data in the table has been obtained with an intake-exhaust pipe measuring 0.5 m in length. Gas flow rates refer to the lower calorific value at a temperature of 15°C and at a pressure of 1013 mbar. The burner pressure values refer to the use of gas at a temperature of 15°C.

		METHANE (G20)			PROPANE (G31)			
THERMAL POWER	THERMAL POWER		BURNER GAS FLOW RATE	PRESS. BURNER NOZZLES		BURNER GAS FLOW RATE	PRESS. BURNER NOZZLES	
(kW)	(kcal/h)		(m³/h)	(mbar)	(mm H <sub>2</sub> O)	(kg/h)	(mbar)	(mm H <sub>2</sub> O)
26.7	22962	D.H.W.	2.93	6.30	64.2	2.15	7.80	79.5
26.0	22360		2.85	6.06	61.8	2.09	7.47	76.2
25.0	21500		2.74	5.73	58.4	2.01	7.01	71.5
24.4	20984	CEN. HEAT. + D.H.W.	2.67	5.53	56.4	1.96	6.74	68.8
23.0	19780		2.51	5.08	51.8	1.84	6.14	62.6
21.8	18733		2.38	4.71	48.0	1.74	5.64	57.5
21.0	18060		2.29	4.48	45.6	1.68	5.33	54.4
20.0	17200		2.18	4.18	42.6	1.60	4.95	50.5
19.0	16340		2.07	3.90	39.7	1.52	4.58	46.7
18.0	15480		1.96	3.62	36.9	1.44	4.22	43.0
17.0	14620		1.86	3.34	34.1	1.36	3.88	39.5
16.0	13760		1.75	3.08	31.4	1.28	3.54	36.1
15.0	12900		1.64	2.82	28.7	1.21	3.22	32.9
14.0	12040		1.54	2.56	26.1	1.13	2.91	29.7
13.0	11180		1.43	2.32	23.6	1.05	2.61	26.7
12.0	10320		1.32	2.07	21.1	0.97	2.33	23.7
11.0	9460		1.21	1.83	18.7	0.89	2.05	20.9
10.0	8600		1.11	1.60	16.3	0.81	1.78	18.2
9.0	7740		1.00	1.37	14.0	0.73	1.53	15.6
8.0	6880		0.89	1.15	11.7	0.65	1.28	13.0
7.0	6020		0.78	0.93	9.5	0.57	1.04	10.6
6.0	5160		0.67	0.72	7.3	0.49	0.82	8.3
5.0	4300		0.56	0.51	5.2	0.41	0.60	6.1
4.0	3440		0.45	0.30	3.1	0.33	0.40	4.0
3.0	2580		0.34	0.10	1.0	0.25	0.20	2.0

## 4.2 COMBUSTION PARAMETERS.

		G20	G31
Supply pressure	mbar (mm H <sub>2</sub> O)	20 (204)	37 (377)
Gas nozzle diameter	mm	5.60	4.00
Flue flow rate at nominal heat output	kg/h (g/s)	43 (11.94) - 40 (11.11)	45 (12.50) - 41 (11.39)
Flue flow rate at min heat output	kg/h (g/s)	6 (1.67)	6 (1.67)
CO <sub>2</sub> at Q. Nom./Min.	%	9.50 / 8.60 (± 0.2)	10.50 / 9.60 (± 0.2)
CO with 0% O <sub>2</sub> at Nom./Min. Q. Nom./Min.	ppm	235 / 3	220 / 4
NO <sub>x</sub> at 0% of O <sub>2</sub> at Q. Nom./Min.	mg/kWh	44 / 12	35 / 13
Flue temperature at nominal output	°C	63	63
Flue temperature at minimum output	°C	47	47
Max air combustion temperature	°C	50	50
Intake / exhaust available head at 5580 revs	Pa	33	---
Intake / exhaust available head at 5790 revs	Pa	75	---
Intake / exhaust available head at 5900 revs	Pa	148	---
Intake / exhaust available head at 5640 revs	Pa	---	33
Intake / exhaust available head at 5820 revs	Pa	---	75
Intake / exhaust available head at 5900 revs	Pa	---	148

Combustion parameters: measuring conditions of useful efficiency (flow temperature/return temperature= 80 / 60 °C), ambient temperature reference = 15°C.



### 4.3 TECHNICAL DATA.

<b>BOILER TECHNICAL DATA</b>		
Domestic hot water nominal heat input	kW (kcal/h)	27.7 (23797)
Central heating nominal heat input	kW (kcal/h)	25.2 (21655)
Minimum heat input	kW (kcal/h)	3.2 (2768)
Domestic hot water nominal heat output (useful)	kW (kcal/h)	26.7 (22962)
Central heating nominal heat output (useful)	kW (kcal/h)	24.4 (20984)
Minimum heat output (useful)	kW (kcal/h)	3.0 (2580)
*Effective thermal efficiency 80/60 Nom./Min.	%	96.9 / 93.2
*Effective thermal efficiency 50/30 Nom./Min.	%	105.3 / 106.8
*Effective thermal efficiency 40/30 Nom./Min.	%	107.5 / 108.8
Casing losses with burner On/Off (80-60°C)	%	0.68 / 0.90
Heat loss at flue with burner On/Off (80-60°C)	%	0.05 / 2.60
Central heating circuit max. operating pressure	bar	3 (0.3)
Maximum heating temperature	°C	90
Adjustable heating temperature (max operating field)	°C	30 - 85
Adjustable heating temperature (min operating field)	°C	25 - 85
System expansion vessel total volume	l	10.8
Heating expansion vessel pre-charge	bar (MPa)	1.0 (0.1)
Total volume domestic hot water expansion vessel	l	4.3
Domestic hot water expansion vessel pre-charge	bar (MPa)	2.5 (0.25)
Appliance water content	l	7.6
High temperature zone total head available with 1000 l/h flow rate	kPa (m H <sub>2</sub> O)	28.8 (2.94)
Low temperature zone total head available with 1000 l/h flow rate	kPa (m H <sub>2</sub> O)	35.0 (3.57)
Hot water production useful heat output	kW (kcal/h)	26.7 (22962)
Domestic hot water adjustable temperature	°C	10 - 60
Domestic hot water circuit min. pressure (dynamic)	bar	0.3 (0.03)
Domestic hot water circuit max. operating pressure	bar	8.0 (0.8)
Flow rate capacity in continuous duty (ΔT 30°C)	l/min	19,0
Domestic hot water performance classification according to N 13203-1		★★★
Weight of full boiler	kg	404.4
Weight of empty boiler	kg	193.8
Electrical connection	V/Hz	230 / 50
Nominal power absorption	A	1.2
Installed electric power	W	165
Boiler circulator pump absorbed power	W	58.5
Value EEI	-	≤ 0.20 - Part. 3
Zone pump absorbed power	W	30.6
Value EEI	-	≤ 0.21 - Part. 2
Fan power absorbed power	W	23.0
Equipment electrical system protection	-	IPX5D
Max temperature of combustion products	°C	75
Max. flue overheating temperature	°C	120
Ambient operating temperature range	°C	0 ÷ +50
Ambient operating temperature range with optional antifreeze kit	°C	--
NO <sub>x</sub> class	-	6
Weighted NO <sub>x</sub>	mg/kWh	52
Weighted CO	mg/kWh	56
(**)Type of appliance	C13-C13x-C33-C33X-C43-C43x-C53-C63-C83-C93-C93x B23p-B33-B53p	
Category	II 2H3P - I 3P	

<b>SOLAR CIRCUIT TECHNICAL DATA</b>		
Maximum continuous operating temperature	°C	130
Maximum peak temperature	°C	150
Safety valve pressure	bar (MPa)	6 (0.6)
Total volume hot water expansion vessel	l	10.8
Expansion vessel factory-set pressure	bar (MPa)	2.5 (0.25)
Content of glycol in the solar circuit	l	2.0
Pump absorbed power	W	33.9
Value EEI	-	≤ 0,20 - Part. 3
Head available with 800 l/h flow rate	kPa (m H <sub>2</sub> O)	46.7 (4.76)
Flow rate regulator control range	l/min.	1 - 6

- The data relevant to domestic hot water performance refer to a dynamic inlet pressure of 2 bar and an inlet temperature of 15°C; the values are measured directly at the boiler outlet considering that to obtain the data declared mixing with cold water is necessary.
- \* Yields refer to the lower heating value.
- The weighted NO<sub>x</sub> value refer to the net calorific value.
- \*\* For type C63 it is forbidden to install the appliance as it came out of the factory, in configurations that require shared flues in positive pressure.

#### 4.4 KEY FOR DATA NAMEPLATE.

Md		Cod. Md	
Sr N°	CHK	Cod. PIN	
Type			
Q <sub>nw</sub> /Q <sub>n</sub> min.	Q <sub>nw</sub> /Q <sub>n</sub> max.	P <sub>n</sub> min.	P <sub>n</sub> max.
PMS	PMW	D	TM
NO <sub>x</sub> Class			
		CONDENSING	

**Note:** the technical data is provided on the data nameplate on the boiler

ENG	
Md	Model
Code Md	Model code
Sr N°	Serial Number
CHK	Check
Code PIN	PIN code
Type	Type of installation (ref. CEN TR 1749)
Q <sub>nw</sub> min.	Minimum DHW heat input
Q <sub>n</sub> min.	Central heating minimum heat input
Q <sub>nw</sub> max.	DHW maximum heat input
Q <sub>n</sub> max.	Central heating maximum heat input
P <sub>n</sub> min.	Minimum heat output
P <sub>n</sub> max.	Maximum heat output
PMS	Maximum system pressure
PMW	Maximum domestic hot water pressure
D	Specific flow rate
TM	Maximum operating temperature
NO <sub>x</sub> Class	NO <sub>x</sub> Class
CONDENSING	Condensing boiler

#### 4.5 TECHNICAL PARAMETERS FOR MIXED BOILERS (IN COMPLIANCE WITH REGULATION 813/2013).

The yields in the following tables refer to the higher heating value.

Model/s:				Hercules Solar 26 2 ErP				
Condensing boiler:				YES				
Low-temperature boiler:				NO				
B1 boiler:				NO				
Cogeneration space heater:				NO			Equipped with a supplementary heater:	NO
Combination heater:				YES				
Item	Symbol	Value	Unit	Item	Symbol	Value	Unit	
Rated heat output	$P_n$	24	kW	Seasonal space heating energy efficiency	$\eta_s$	92	%	
For boiler space heaters and boiler combination heaters: useful heat output				For boiler space heaters and boiler combination heaters: Useful efficiency				
At rated heat output and high-temperature regime (*)	$P_4$	24.4	kW	At rated heat output and high-temperature regime (*)	$\eta_4$	87.0	%	
At 30 % of rated heat output and low-temperature regime (**)	$P_1$	8.2	kW	At 30 % of rated heat output and low-temperature regime (**)	$\eta_1$	97.2	%	
Auxiliary electricity consumption				Other items				
At full load	$el_{max}$	0.039	kW	Standby heat loss	$P_{stby}$	0.132	kW	
At part load	$el_{min}$	0.019	kW	Ignition burner power consumption	$P_{ign}$	0.000	kW	
In standby mode	$P_{SB}$	0,005	kW	Emissions of nitrogen oxides	$NO_x$	47	mg / kWh	
For combination heaters:								
Declared load profile	XL			Water heating energy efficiency	$\eta_{WH}$	80	%	
Daily electricity consumption	$Q_{elec}$	0.220	kWh	Daily fuel consumption	$Q_{fuel}$	30.464	kWh	
Contact details	IMMERGAS S.p.A. VIA CISA LIGURE, 95 - 42041 BRESCELLO (RE) ITALY							
(*) High-temperature regime means 60 °C return temperature at heater inlet and 80 °C feed temperature at heater outlet.								
(**) Low temperature means for condensing boilers 30 °C, for low-temperature boilers 37 °C and for other heaters 50 °C return temperature.								

4.6 PRODUCT FICHE (IN COMPLIANCE WITH REGULATION 811/2013).

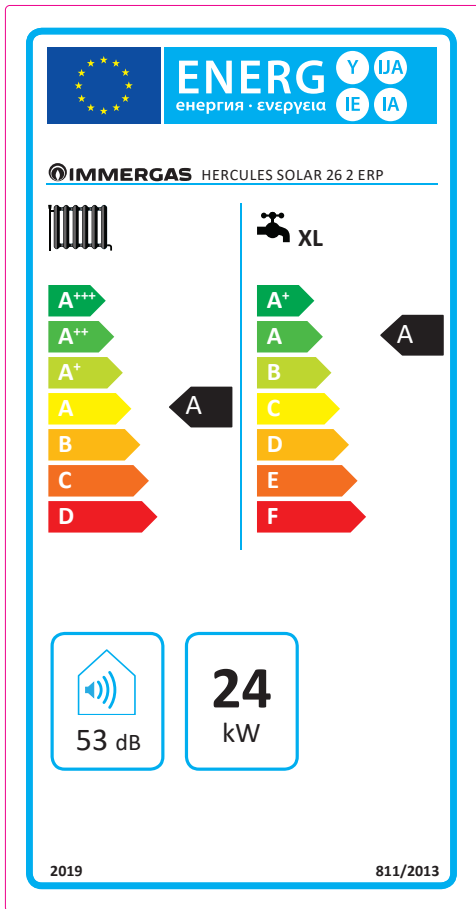

Parameter	value
Yearly energy consumption for the heating function ( $Q_{HE}$ )	41.8 GJ
Yearly electricity consumption for the domestic hot water function (AEC)	48 kWh
Yearly fuel consumption for the domestic hot water function (AFC)	18 GJ
Seasonal room heating yield ( $\eta_s$ )	92 %
Domestic hot water production yield ( $\eta_{wh}$ )	80 %

For proper installation of the device, refer to chapter 1 of this booklet (for the installer) and current installation regulations. For proper maintenance refer to chapter 3 of this booklet (for the maintenance technician) and adhere to the frequencies and methods set out herein.

#### 4.7 PARAMETERS FOR FILLING IN THE PACKAGE FICHE.

In case you should wish to install an assembly, starting from the Hercules Solar 26 2 ErP boiler, use the package fiches in fig. 58 e 61. For correctly filling in, enter the figures shown in tables fig. 57 and 60 (as shown in the facsimile package fiche fig. 56 and 59) . The remaining values must be obtained from the technical data sheets of the products used to make up the assembly (e.g. solar devices, integration heat pumps, temperature controllers).

Use fiche fig. 58 for “packages” related to the heating function (e.g.: boiler + temperature controller).

Use fiche fig. 61 for “packages” related to the domestic hot water function (e.g.: boiler + solar thermal system).

#### Facsimile for filling in the package fiche for room central heating systems.

Seasonal central heating energy efficiency of the boiler	① <input style="width: 50px;" type="text" value="I"/> %																														
Temperature control From temperature control board	+ <input style="width: 50px;" type="text" value=""/> %																														
<div style="border: 1px solid black; padding: 5px; display: inline-block;">             Class I = 1 %. Class II = 2 %.              Class III = 1.5 %. Class IV = 2 %.              Class V = 3 %. Class VI = 4 %.              Class VII = 3.5 %. Class VIII = 5 %           </div>																															
Supplementary boiler From boiler board	± <input style="width: 50px;" type="text" value=""/> %																														
<div style="border: 1px solid black; padding: 5px; display: inline-block;">             Seasonal central heating energy efficiency (in %)           </div> $( \text{ } - \text{'I'} ) \times 0.1 = \pm \text{ } \%$																															
<b>Solar contribution</b>																															
<i>From the board of the solar device</i>																															
<div style="border: 1px solid black; padding: 2px; display: inline-block; margin-right: 10px;">             Dimensions of the manifold (in m<sup>2</sup>)           </div> <div style="border: 1px solid black; padding: 2px; display: inline-block; margin-right: 10px;">             Volume of the tank (in m<sup>3</sup>)           </div> <div style="border: 1px solid black; padding: 2px; display: inline-block; margin-right: 10px;">             Efficiency of the manifold (in %)           </div> <div style="border: 1px solid black; padding: 2px; display: inline-block;">             Classification of the tank              A* = 0.95. A = 0.91.              B = 0.86. C = 0.83.              D-G = 0.81           </div>	④ <input style="width: 50px;" type="text" value=""/> %																														
$( \text{'III'} \times \text{ } + \text{'IV'} \times \text{ } ) \times (0.9 \times ( \text{ } / 100 ) \times \text{ } = + \text{ } \%$																															
Supplementary heat pump From the heat pump board	+ <input style="width: 50px;" type="text" value=""/> %																														
<div style="border: 1px solid black; padding: 5px; display: inline-block;">             Seasonal central heating energy efficiency (in %)           </div> $( \text{ } - \text{'I'} ) \times \text{'II'} = + \text{ } \%$																															
<b>Solar contribution and supplementary heat pump</b>																															
Select the lowest value	- <input style="width: 50px;" type="text" value=""/> %																														
$0.5 \times \text{ } \text{ O } 0.5 \times \text{ } = - \text{ } \%$																															
Seasonal central heating energy efficiency of the set	⑦ <input style="width: 50px;" type="text" value=""/> %																														
Seasonal central heating energy efficiency class of the set																															
<div style="border: 1px solid black; padding: 10px; display: inline-block;"> <table style="width: 100%; text-align: center;"> <tr> <td><input type="checkbox"/></td><td><input type="checkbox"/></td><td><input type="checkbox"/></td><td><input type="checkbox"/></td><td><input type="checkbox"/></td><td><input type="checkbox"/></td><td><input type="checkbox"/></td><td><input type="checkbox"/></td><td><input type="checkbox"/></td><td><input type="checkbox"/></td> </tr> <tr> <td><b>G</b></td><td><b>F</b></td><td><b>E</b></td><td><b>D</b></td><td><b>C</b></td><td><b>B</b></td><td><b>A</b></td><td><b>A<sup>+</sup></b></td><td><b>A<sup>++</sup></b></td><td><b>A<sup>+++</sup></b></td> </tr> <tr> <td>&lt; 30 %</td><td>≥ 30 %</td><td>≥ 34 %</td><td>≥ 36 %</td><td>≥ 75 %</td><td>≥ 82 %</td><td>≥ 90 %</td><td>≥ 98 %</td><td>≥ 125 %</td><td>≥ 150 %</td> </tr> </table> </div>		<input type="checkbox"/>	<input type="checkbox"/>	<input type="checkbox"/>	<input type="checkbox"/>	<input type="checkbox"/>	<input type="checkbox"/>	<input type="checkbox"/>	<input type="checkbox"/>	<input type="checkbox"/>	<input type="checkbox"/>	<b>G</b>	<b>F</b>	<b>E</b>	<b>D</b>	<b>C</b>	<b>B</b>	<b>A</b>	<b>A<sup>+</sup></b>	<b>A<sup>++</sup></b>	<b>A<sup>+++</sup></b>	< 30 %	≥ 30 %	≥ 34 %	≥ 36 %	≥ 75 %	≥ 82 %	≥ 90 %	≥ 98 %	≥ 125 %	≥ 150 %
<input type="checkbox"/>	<input type="checkbox"/>	<input type="checkbox"/>	<input type="checkbox"/>	<input type="checkbox"/>	<input type="checkbox"/>	<input type="checkbox"/>	<input type="checkbox"/>	<input type="checkbox"/>	<input type="checkbox"/>																						
<b>G</b>	<b>F</b>	<b>E</b>	<b>D</b>	<b>C</b>	<b>B</b>	<b>A</b>	<b>A<sup>+</sup></b>	<b>A<sup>++</sup></b>	<b>A<sup>+++</sup></b>																						
< 30 %	≥ 30 %	≥ 34 %	≥ 36 %	≥ 75 %	≥ 82 %	≥ 90 %	≥ 98 %	≥ 125 %	≥ 150 %																						
Boiler and supplementary heat pump installed with low temperature heat emitters at 35 °C? From the board of the heat pump.	⑦ <input style="width: 50px;" type="text" value=""/> + ( 50 x 'II' ) = <input style="width: 50px;" type="text" value=""/> %																														
<i>The energy efficiency of the set of products indicated in this fiche may not reflect the actual energy efficiency after installation since such efficiency is affected by additional factors. such as the heat loss in the distribution system and the size of the products compared to the size and features of the building.</i>																															

**Parameters for filling in the package fiche.**

Parameter	Hercules Solar 26 2 ErP
'I'	92
'II'	*
'III'	1.11
'IV'	0.44

\* to be established by means of table 5 of Regulation 811/2013 in case of "package" including a heat pump to integrate the boiler. In this case the boiler must be considered as the main appliance of the assembly.

57

**Room central heating system package fiche.**

Seasonal central heating energy efficiency of the boiler 1  %

Temperature control  
From temperature control board

Class I = 1 %. Class II = 2 %.  
 Class III = 1.5 %. Class IV = 2 %.  
 Class V = 3 %. Class VI = 4 %.  
 Class VII = 3.5 %. Class VIII = 5 %

+ 2  %

Supplementary boiler  
From boiler board

Seasonal central heating energy efficiency (in %)

(  - \_\_\_\_\_ ) x 0.1 = ± 3  %

Solar contribution  
From the board of the solar device

Dimensions of the manifold (in m<sup>2</sup>)

Volume of the tank (in m<sup>3</sup>)

Efficiency of the manifold (in %)

Classification of the tank  
A\* = 0.95. A = 0.91.  
B = 0.86. C = 0.83.  
D-G = 0.81

( \_\_\_\_\_ x  + \_\_\_\_\_ x  ) x ( 0.9 x (  / 100 ) x  = + 4  %

Supplementary heat pump  
From the heat pump board

Seasonal central heating energy efficiency (in %)

(  - \_\_\_\_\_ ) x \_\_\_\_\_ = + 5  %

Solar contribution and supplementary heat pump

Select the lowest value 0.5 x 4  O 0.5 x 5  = - 6  %

Seasonal central heating energy efficiency of the set 7  %

Seasonal central heating energy efficiency class of the set

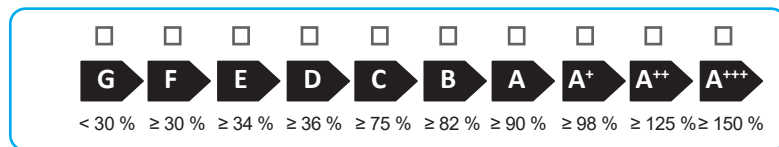

Boiler and supplementary heat pump installed with low temperature heat emitters at 35 °C?

From the board of the heat pump. 7  + ( 50 x \_\_\_\_\_ ) =  %

The energy efficiency of the set of products indicated in this fiche may not reflect the actual energy efficiency after installation since such efficiency is affected by additional factors, such as the heat loss in the distribution system and the size of the products compared to the size and features of the building.

58

Facsimile for filling in the domestic hot water production system package fiche.

Water heating energy efficiency of combination boiler

<sup>1</sup>  
 %

Stated load profile:

Solar contribution

From the board of the solar device

Auxiliary electricity

$$(1.1 \times \text{'I'} - 10\%) \times \text{'II'} - \text{'III'} - \text{'I'} = + \text{$$

<sup>2</sup>  
 %

Water heating energy efficiency of the set in average climate conditions

<sup>3</sup>  
 %

Water heating energy efficiency class of the set in average climate conditions

	<input type="checkbox"/>	<input type="checkbox"/>	<input type="checkbox"/>	<input type="checkbox"/>	<input type="checkbox"/>	<input type="checkbox"/>	<input type="checkbox"/>	<input type="checkbox"/>	<input type="checkbox"/>	<input type="checkbox"/>
	<b>G</b>	<b>F</b>	<b>E</b>	<b>D</b>	<b>C</b>	<b>B</b>	<b>A</b>	<b>A<sup>+</sup></b>	<b>A<sup>++</sup></b>	<b>A<sup>+++</sup></b>
<input type="checkbox"/> <b>M</b>	< 27 %	≥ 27 %	≥ 30 %	≥ 33 %	≥ 36 %	≥ 39 %	≥ 65 %	≥ 100 %	≥ 130 %	≥ 163 %
<input type="checkbox"/> <b>L</b>	< 27 %	≥ 27 %	≥ 30 %	≥ 34 %	≥ 37 %	≥ 50 %	≥ 75 %	≥ 115 %	≥ 150 %	≥ 188 %
<input type="checkbox"/> <b>XL</b>	< 27 %	≥ 27 %	≥ 30 %	≥ 35 %	≥ 38 %	≥ 55 %	≥ 80 %	≥ 123 %	≥ 160 %	≥ 200 %
<input type="checkbox"/> <b>XXL</b>	< 28 %	≥ 28 %	≥ 32 %	≥ 36 %	≥ 40 %	≥ 60 %	≥ 85 %	≥ 131 %	≥ 170 %	≥ 213 %

Water heating energy efficiency class in colder and hotter climate conditions

Colder: <sup>3</sup> - 0.2 x <sup>2</sup> =  %

Hotter: <sup>3</sup> + 0.4 x <sup>2</sup> =  %

*The energy efficiency of the set of products indicated in this fiche may not reflect the actual energy efficiency after installation since such efficiency is affected by additional factors, such as the heat loss in the distribution system and the size of the products compared to the size and features of the building.*



Parameters for filling in the DHW package fiche.

Parameter	Hercules Solar 26 2 ErP
‘I’	80
‘II’	*
‘III’	*

\* to be determined according to Regulation 811/2013 and transient calculation methods as per Notice of the European Community no. 207/2014.

58

Domestic hot water production system package fiche.

Water heating energy efficiency of combination boiler

%

Stated load profile:

Solar contribution

From the board of the solar device

Auxiliary electricity

( 1.1 x \_\_\_\_\_ - 10% ) x \_\_\_\_\_ -  - \_\_\_\_\_ =

+  %

Water heating energy efficiency of the set in average climate conditions

%

Water heating energy efficiency class of the set in average climate conditions

	G	F	E	D	C	B	A	A <sup>+</sup>	A <sup>++</sup>	A <sup>+++</sup>
<input type="checkbox"/> M	< 27 %	≥ 27 %	≥ 30 %	≥ 33 %	≥ 36 %	≥ 39 %	≥ 65 %	≥ 100 %	≥ 130 %	≥ 163 %
<input type="checkbox"/> L	< 27 %	≥ 27 %	≥ 30 %	≥ 34 %	≥ 37 %	≥ 50 %	≥ 75 %	≥ 115 %	≥ 150 %	≥ 188 %
<input type="checkbox"/> XL	< 27 %	≥ 27 %	≥ 30 %	≥ 35 %	≥ 38 %	≥ 55 %	≥ 80 %	≥ 123 %	≥ 160 %	≥ 200 %
<input type="checkbox"/> XXL	< 28 %	≥ 28 %	≥ 32 %	≥ 36 %	≥ 40 %	≥ 60 %	≥ 85 %	≥ 131 %	≥ 170 %	≥ 213 %

Water heating energy efficiency class in colder and hotter climate conditions

Colder:  % - 0.2 x  % =  %

Hotter:  % + 0.4 x  % =  %

The energy efficiency of the set of products indicated in this fiche may not reflect the actual energy efficiency after installation since such efficiency is affected by additional factors, such as the heat loss in the distribution system and the size of the products compared to the size and features of the building.

60







This instruction booklet  
is made of ecological paper



[immergas.com](http://immergas.com)

Immergas S.p.A.  
42041 Brescello (RE) - Italy  
Tel. 0522.689011  
Fax 0522.680617



**IMMERGAS**  
IMMERGAS SPA - ITALY  
CERTIFIED COMPANY  
UNI EN ISO 9001:2015

Design, manufacture and post-sale assistance of gas  
boilers, gas water heaters and related accessories

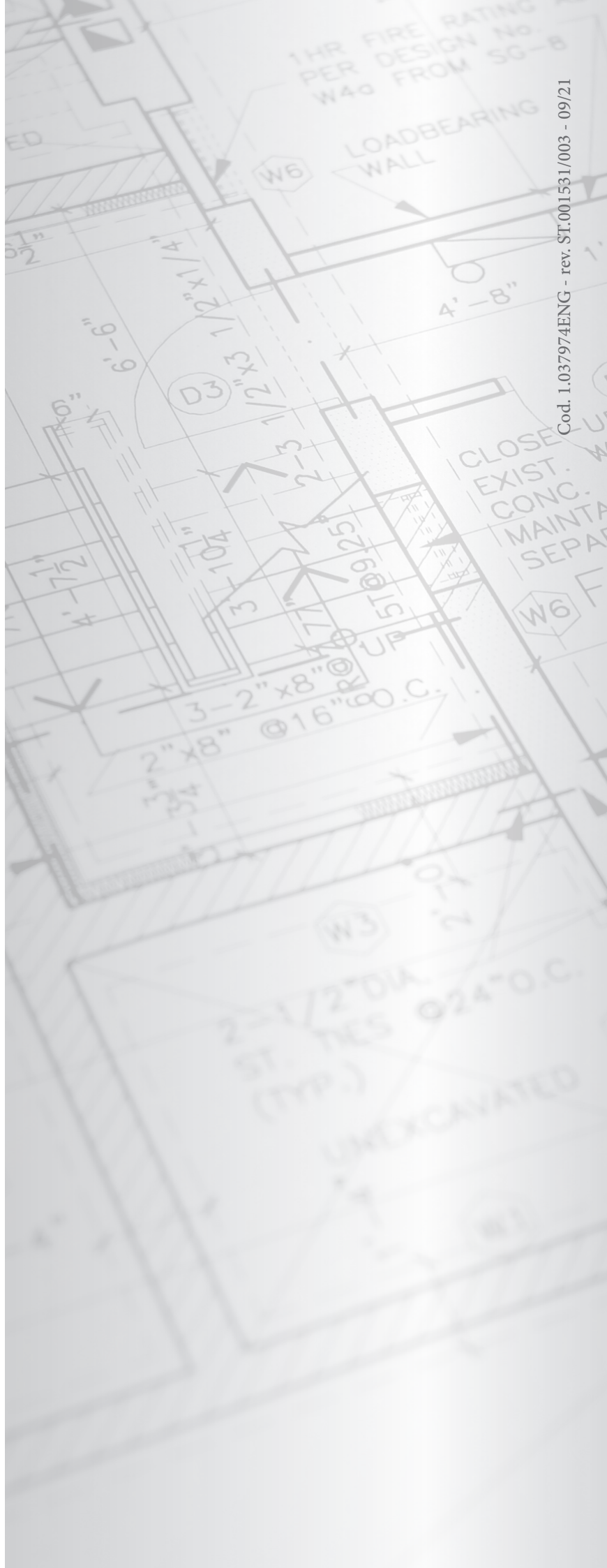

Cod. I.037974ENG - rev. ST.001531/003 - 09/21