

MAGIS HERCULES PRO MINI 6/9 EH

IE

Instructions and recommendations

Installer

User

Maintenance technician

Technical Data

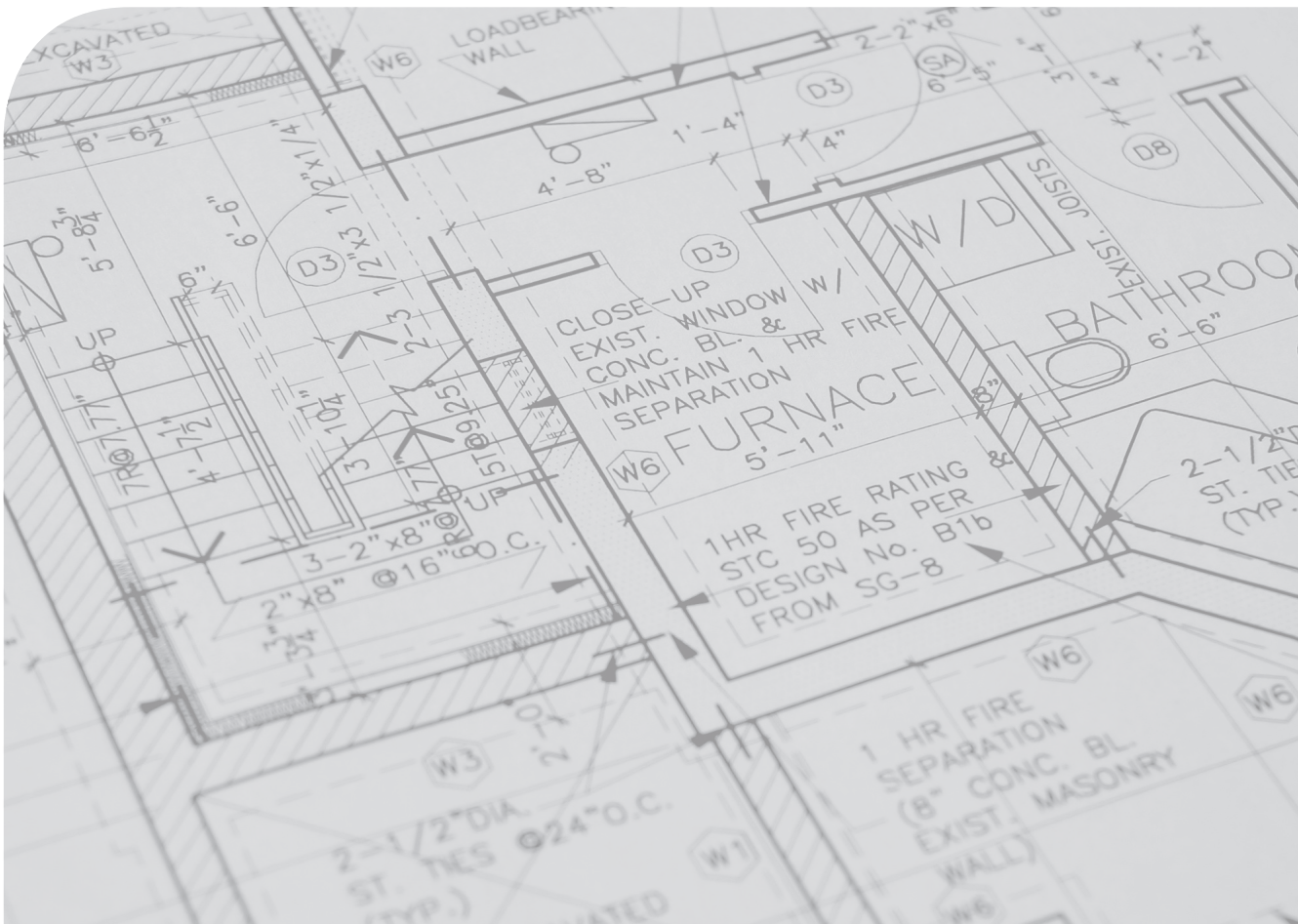

INDEX

Dear Customer.....	4
General Recommendations.....	5
Safety symbols used.....	6
Personal protective equipment	6
1 Installing the Indoor Unit.....	7
1.1 Description of the product	7
1.2 Installation warnings	7
1.3 Data plate.....	10
1.4 Indoor Unit main dimensions	12
1.5 Minimum indoor unit installation distances	13
1.6 Indoor unit hydraulic connection	14
1.7 Connecting the chiller line.....	15
1.8 Electrical connection.....	16
1.9 Remote zone control (Optional)	23
1.10 MODBUS temperature and humidity room probes (Optional).....	24
1.11 Room chrono-thermostats (Optional)	25
1.12 Humidistat ON/OFF (Optional)	25
1.13 Dehumidifiers (optional)	25
1.14 External temperature probe (Optional).....	26
1.15 Dominus (Optional)	26
1.16 Temperature control setting	27
1.17 System filling	28
1.18 Operating limits.....	28
1.19 Indoor Unit start-up (ignition)	29
1.20 Circulation pump.....	30
1.21 Domestic hot water storage tank unit.....	32
1.22 Kits available on request	33
1.23 Main components	34
2 Instructions for use and maintenance	35
2.1 General recommendations	35
2.2 Cleaning and maintenance	37
2.3 Control panel.....	37
2.4 System use	38
2.5 Operating mode	40
2.6 Parameters and information menu	46
2.7 Fault and anomaly signals	60
2.8 Restore central heating system pressure	70
2.9 Draining the system.....	70
2.10 Emptying the D.H.W. circuit.....	71
2.11 Storage tank draining	71
2.12 Cleaning the case.....	71
2.13 Permanent shutdown.....	71
3 Instructions for maintenance and initial check.....	72
3.1 General recommendations	72
3.2 Initial check	73
3.3 Yearly appliance check and maintenance	73
3.4 Finned air coil maintenance.....	74
3.5 Hydraulic diagram.....	75
3.6 Wiring diagram.....	77
3.7 System filter.....	84
3.8 Troubleshooting.....	84



3.9	P.C.B. programming.....	85
3.10	First ignition parameter setting.....	98
3.11	DHW (Domestic hot water) BOOST.....	100
3.12	Anti-legionella.....	100
3.13	DHW (Domestic hot water) recirculation.....	100
3.14	Pump anti-block.....	101
3.15	Three-way anti-block.....	101
3.16	System setpoint correction.....	101
3.17	Integration with system internal electrical resistance.....	102
3.18	Integration with system external electrical resistances.....	103
3.19	Zone 2/3 safety thermostat.....	103
3.20	Conjunction Mode.....	103
3.21	Heat pump disabling function.....	104
3.22	Power reduction function.....	104
3.23	Diverter valve management (summer / winter).....	104
3.24	Diverter valve management (DHW/System) (Optional).....	104
3.25	Heat pump circulator function.....	104
3.26	External probe setting.....	105
3.27	Manual drives.....	105
3.28	Outdoor unit Testmode Function.....	105
3.29	Outdoor Unit Pump Down.....	105
3.30	Supervision device configuration.....	105
3.31	Photovoltaic function.....	105
3.32	Access to control panel and electrical panel.....	106
3.33	Casing removal.....	109
4	Technical data.....	111
4.1	Technical data table.....	111
4.2	Magis Hercules PRO MINI 6 EH product fiche (in compliance with Regulation 811/2013).....	113
4.3	Table 2 Regulation 813/2013.....	114
4.4	Magis Hercules PRO MINI 9 EH product fiche (in compliance with Regulation 811/2013).....	115
4.5	Table 2 Regulation 813/2013.....	116
4.6	Parameters for filling in the package fiche.....	117



Dear Customer

Congratulations for having chosen a top-quality Immergas product, able to assure well-being and safety for a long period of time. As an Immergas customer you can also count on a Qualified Authorised After-Sales Technical Assistance Centre, prepared and updated to guarantee the constant efficiency of your products. Read the following pages carefully: you will be able to draw useful tips on the proper use of the device, compliance with which will confirm your satisfaction with the Immergas product.

For assistance and routine maintenance, contact Authorised Technical Service Centres: they have original spare parts and are specifically trained directly by the manufacturer.

Thermal systems must undergo periodic maintenance and scheduled checks of the energy efficiency in compliance with national, regional or local provisions in force.

The company **IMMERGAS S.p.A.**, with registered office in via Cisa Ligure 95 42041 Brescello (RE), declares that the design, manufacturing and after-sales assistance processes comply with the requirements of standard **UNI EN ISO 9001:2015**.

For further details on the product CE marking, request a copy of the Declaration of Conformity from the manufacturer, specifying the appliance model and the language of the country.

The manufacturer declines all liability due to printing or transcription errors, reserving the right to make any modifications to its technical and commercial documents without forewarning.





GENERAL RECOMMENDATIONS

This book contains important information for the:

Installer (section 1);

User (section 2);

Maintenance Technician (section 3).

- The user must carefully read the instructions in the specific section (section 2).
- The user must limit operations on the appliance only to those explicitly allowed in the specific section.
- The appliance must be installed by qualified and professionally trained personnel.
- It must be stored with care and consulted carefully, as all of the warnings provide important safety indications for installation, use and maintenance stages.
- In compliance with the legislation in force, the systems must be designed by qualified professionals, within the dimensional limits established by the Law. Installation and maintenance must be performed in compliance with the regulations in force, according to the manufacturer's instructions and by professionally qualified staff, meaning staff with specific technical skills in the plant sector, as provided for by Law.
- Improper installation or assembly of the Immergas device and/or components, accessories, kits and devices can cause unexpected problems for people, animals and objects. Read the instructions provided with the product carefully to ensure proper installation.
- This instructions manual provides technical information for installing Immergas products. As for the other issues related to the installation of products (e.g. safety at the workplace, environmental protection, accident prevention), it is necessary to comply with the provisions of the standards in force and the principles of good practice.
- All Immergas products are protected with suitable transport packaging.
- The material must be stored in a dry place protected from the weather.
- Damaged products must not be installed.
- Maintenance must be carried out by skilled technical staff. For example, the Authorised Service Centre that represents a guarantee of qualifications and professionalism.
- The appliance must only be destined for the use for which it has been expressly declared. Any other use will be considered improper and therefore potentially dangerous.
- If errors occur during installation, operation and maintenance, due to non-compliance with technical laws in force, standards or instructions contained in this booklet (or however supplied by the manufacturer), the manufacturer is excluded from any contractual and extra-contractual liability for any damages and the device warranty is invalidated.
- In the event of malfunctions, faults or incorrect operation, turn the appliance off and contact an authorised company (e.g. the Authorised Technical Assistance Centre, which has specifically trained staff and original spare parts). Do not attempt to modify or repair the appliance alone.



SAFETY SYMBOLS USED



GENERIC HAZARD

Strictly follow all of the indications next to the pictogram. Failure to follow the indications can generate hazard situations resulting in possible harm to the health of the operator and user in general, and/or property damage.



ELECTRICAL HAZARD

Strictly follow all of the indications next to the pictogram. The symbol indicates the appliance's electrical components or, in this manual, identifies actions that can cause an electrical hazard.



WARNING FOR INSTALLER

Read the instruction booklet carefully before installing the product.



LOW FLAMMABILITY MATERIAL

The symbol indicates that the appliance contains low flammability material.



WARNINGS

Strictly follow all of the indications next to the pictogram. Failure to follow the indications can generate hazard situations resulting in possible minor injuries to the health of both the operator and the user in general, and/or slight material damage.



ATTENTION

Read and understand the instructions of the appliance before carrying out any operation, carefully following the instructions given. Failure to observe the instructions may result in malfunction of the unit.



INFORMATION

Indicates useful tips or additional information.



EARTH TERMINAL CONNECTION

The symbol identifies the appliance's earth terminal connection point.



DISPOSAL WARNING

The user must not dispose of the appliance at the end of its service life as municipal waste, but send it to appropriate collection centres.

PERSONAL PROTECTIVE EQUIPMENT



SAFETY GLOVES



EYE PROTECTION



SAFETY FOOTWEAR



1 INSTALLING THE INDOOR UNIT

1.1 DESCRIPTION OF THE PRODUCT

Magis Hercules Pro Mini 6-9 EH is a heat pump consisting of:

- UIMHPM EH indoor unit (hereinafter called, indoor unit or UIMHPM EH).
- Audax Pro 6-9 V2 outdoor unit (hereinafter referred to as outdoor unit or Audax Pro 6-9 V2).

Magis Hercules Pro Mini 6-9 EH is perfectly operational only if the two units are correctly powered and interconnected.

The UIMHPM EH indoor unit was designed solely for floor installation for heating and air conditioning and to produce domestic hot water for domestic use and similar purposes.

For normal operation it must be paired with one of the following outdoor units:

- Audax Pro 6 V2;
- Audax Pro 9 V2.

Accordingly, it is necessary to comply with all of the rules regarding safety and the use of both appliances.

1.2 INSTALLATION WARNINGS



Operators who install and service the appliance must wear the personal protective equipment required by applicable law.



The place of installation of the appliance and relative Immergas accessories must have suitable features (technical and structural), such as to allow for (always in safe, efficient and comfortable conditions):

- installation (according to the provisions of technical legislation and technical regulations);
- maintenance operations (including scheduled, periodic, routine and special maintenance);
- removal (to outdoors in the place for loading and transporting the appliances and components) as well as the eventual replacement of those with appliances and/or equivalent components.



Installation must be carried out according to regulation standards, current legislation and in compliance with local technical regulations and the required technical procedures.



The appliance operates with R32 refrigerant gas.

This gas is ODOURLESS.

Pay the utmost attention

Strictly follow the instruction handbook of the Outdoor Unit before installation and any type of operation on the chiller circuit.



R32 refrigerant gas belongs to the low flammability refrigerant category: class A2L according to standard ISO 817. It guarantees high performance with low environmental impact. The new gas reduces the potential environmental impact by one third compared to R410A, having less effect on global warming (GWP 675).



The manufacturer declines all liability in the event of damage caused by appliances removed from other systems or for any non-conformities with such equipment.





Only a professionally enabled company is authorised to install Immergas appliances.



Check the environmental operating conditions of all parts relevant to installation, referring to this booklet.



If installing a kit or servicing the appliance, always empty the system's domestic hot water circuit first so as not to compromise the appliance's electrical safety (Par. 2.9, 2.10).

Always disconnect the appliance from voltage and, depending on the type of operation, decrease the pressure and/or bring it to zero in the gas and DHW circuits.



Before installing the appliance, ensure that it is delivered in perfect condition; if in doubt, contact the supplier immediately. Packing materials (staples, nails, plastic bags, polystyrene foam, etc.) constitute a hazard and must be kept out of the reach of children.

If the appliance is installed inside or between cabinets, ensure sufficient space for routine servicing; for minimum installation distances, see Fig. 4.



Keep all combustible material away from the appliance (paper, rags, plastic, polystyrene, etc.).



Any modification to the appliance that is not explicitly indicated in this section of the booklet is forbidden.

Installation standards



This appliance must be installed indoors or outdoors in a partially protected area where the temperature cannot drop below 0 °C.

By partially protected area, we mean one in which the appliance is not directly exposed to the elements (rain, snow, hail, etc.).



This type of installation is possible when permitted by the laws in force in the appliance's country of destination.



Do not install in places/rooms that constitute public areas of apartment buildings, internal stairways or other escape routes (e.g. floor landings, entrance halls, etc.).



To prevent electrocution, fire or injury, always switch off the unit, disable the protective switch and, if smoke escapes or if the unit is extremely noisy, contact the Authorised After-Sales Technical Assistance Centre.



Do not install near sources of heat.



Pay attention not to generate sparks as follows:

- Do not remove the fuses while the unit is on.
- Do not unplug the unit while it is on.

It is recommended to install the outlet high up. Lay the cables in such a way that they do not get tangled.



This Indoor Unit is used to heat water to below boiling temperature in atmospheric pressure.



They must be connected to a central heating system and domestic hot water circuit suited to their performance and capacity.



The appliance is built to also operate in cooling mode.

If cold water production, during summer, could interfere and damage the central heating only systems, necessary precautions must be taken to prevent that an unintentional production of cold water enters the heating only system.



Failure to comply with the above implies personal responsibility and invalidates the warranty.

“Anti-legionella” thermal treatment of the accumulation storage tank.



The anti-Legionella function is programmed directly on the control panel.

During this phase, the temperature of the water inside the tank exceeds 60°C with the subsequent risk of burns.

Keep this domestic hot water treatment under control (and inform the users) to prevent unforeseeable damage to people, animals, things. If required install a thermostatic valve on the domestic hot water outlet to prevent scalding.



For correct operation of the system, check that the minimum flow rate in operating conditions never drops below 500l/h without system integrative resistance and 1000 l/h if there is the system integrative resistance.



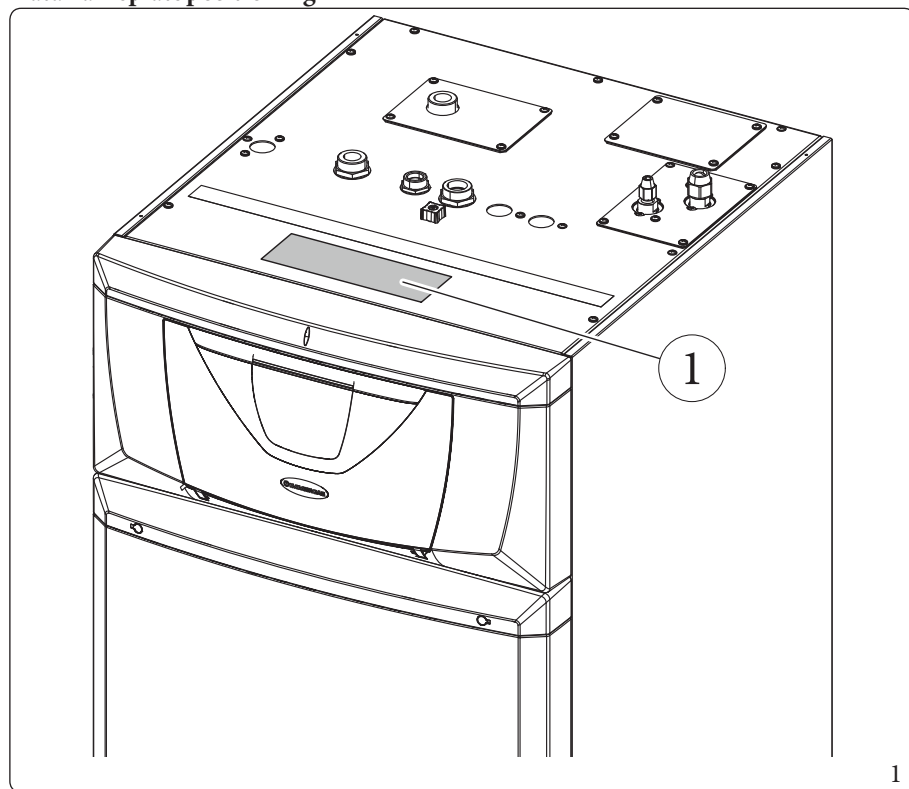

1.3 DATAPLATE

Data nameplate positioning



Key (Fig. 1):
1 - Dataplate

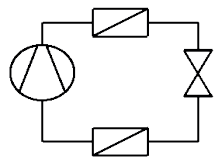

Key for data nameplate

Md.	Cod.Md.	Sr N°	CHK
T.A.			
 	MPa Max.		GWP PS HI PS LO

2

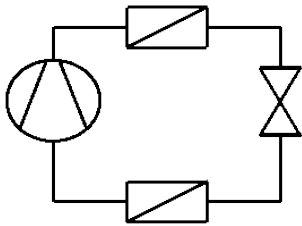

The technical data are provided on the data plate on the appliance.

ENG	
Md.	Model
CodeMd.	Model code
SrN°	Serial Number
CHK	Check
T.A.	Minimum and maximum installation room temperature
 	Achievable temperatures for Cooling and Heating respectively (Minimum and maximum system temperature)
MPa Max.	Maximum water circuit pressure
	Heat pump circuit representation
GWP	Global warming potential of the refrigerant gas versus carbon dioxide
PSHI	Maximum operating pressure of refrigerant gas
PSLO	Minimum operating pressure of refrigerant gas

INSTALLER

USER

MAINTENANCE TECHNICIAN

TECHNICAL DATA



1.4 INDOOR UNIT MAIN DIMENSIONS

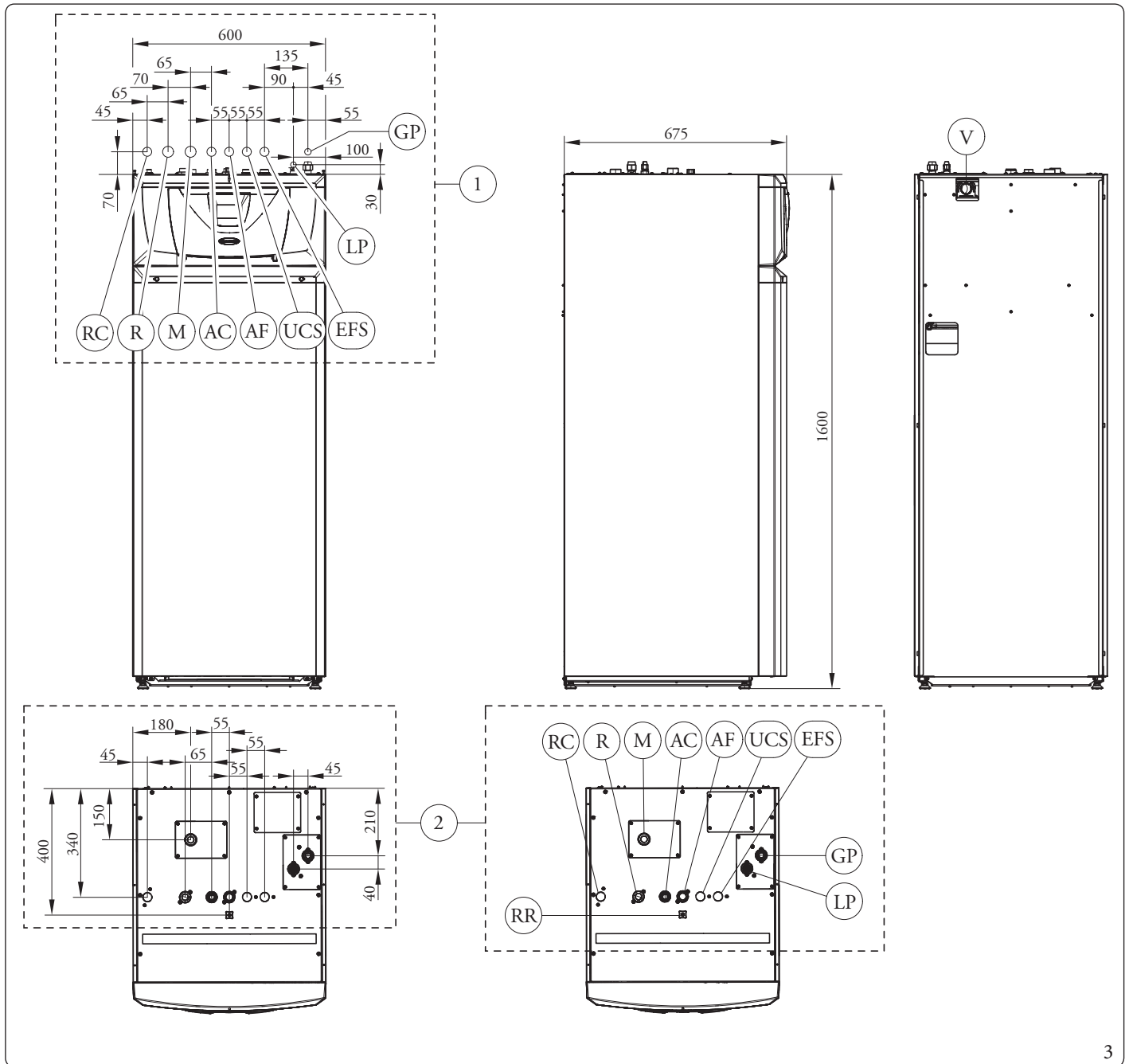

3

Key (Fig. 3):

- GP - Chiller line - gaseous phase
- LP - Chiller line - liquid phase
- R - System return
- M - System flow
- AC - Domestic hot water outlet
- AF - DHW (Domestic hot water) water inlet
- RC - Pump (optional)

- UCS - Solar heat exchanger outlet (optional)
- EFS - Solar cold exchanger inlet (optional)
- V - Electrical connections
- RR - Filling

- 1 - Wall-mounted hydraulic connection with Immergas template (*)
- 2 - Direct hydraulic connection in heat pump (*)

Height (mm)	Width (mm)	Depth (mm)
1600	600	675

(*) Connection dimensions see table on next page.



DIRECT HEAT PUMP CONNECTIONS						
CHILLER LINE		DOMESTIC HOT WATER		RECIRCULATION	SYSTEM	SOLAR SYSTEM
LP	GP	AC	AF	RC	M-R	UCS-EFS
SAE 1/4"	SAE 5/8"	G 3/4"	G 1"	G 3/4"	G 1"	G 3/4"

WALL CONNECTIONS WITH TEMPLATE						
CHILLER LINE		DOMESTIC HOT WATER		RECIRCULATION	SYSTEM	SOLAR SYSTEM
LP	GP	AC	AF	RC	M-R	UCS-EFS
SAE 1/4"	SAE 5/8"	G 3/4"	G 3/4"	G 3/4"	G 1"	G 3/4"

1.5 MINIMUM INDOOR UNIT INSTALLATION DISTANCES

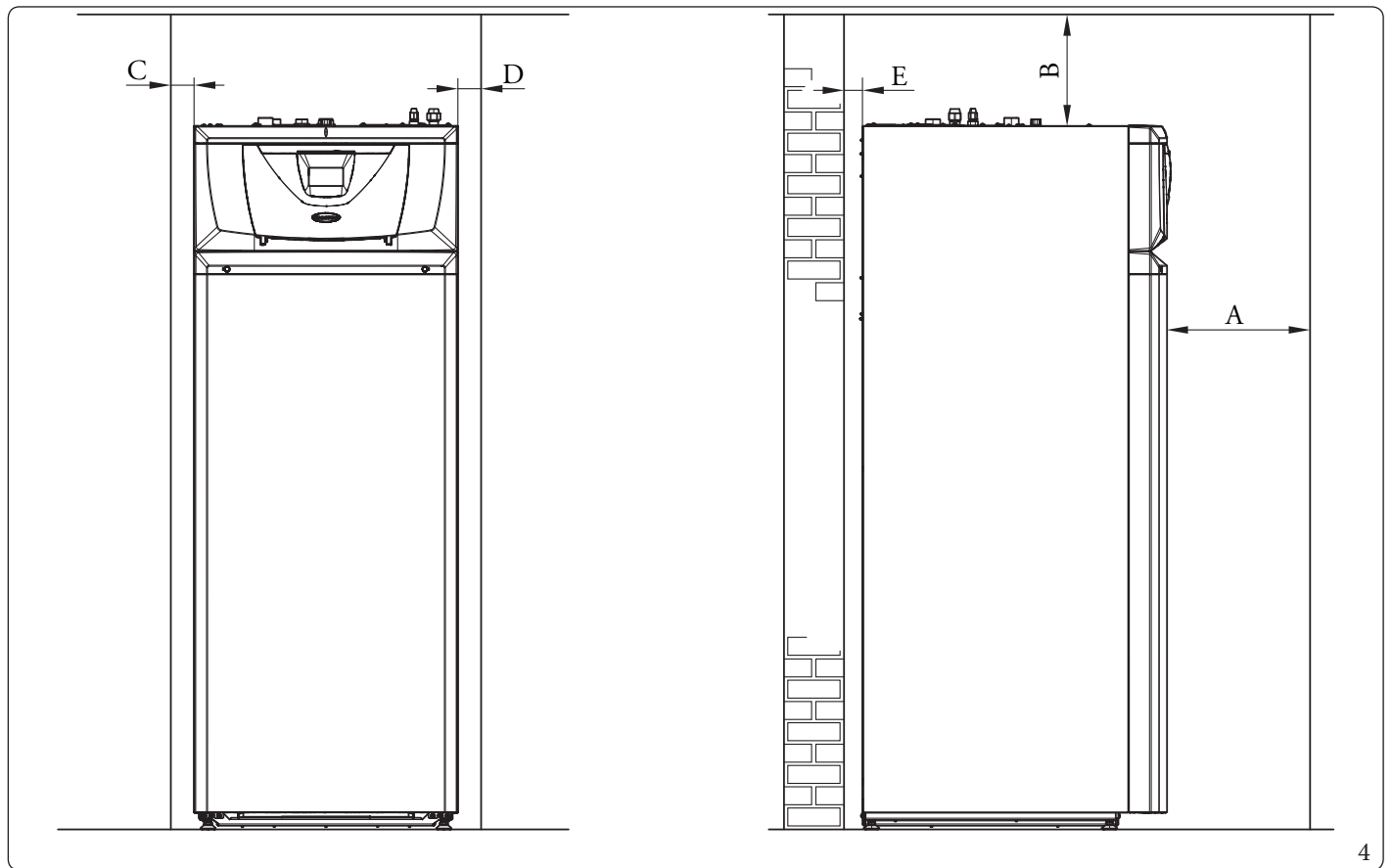

Key (Fig. 4):

- A - 800 mm
- B - 300 mm
- C - 30 mm
- D - 30 mm
- E - 10 mm

INSTALLER

USER

MAINTENANCE TECHNICIAN

TECHNICAL DATA



1.6 INDOOR UNIT HYDRAULIC CONNECTION

3 and 8 bars safety valve



The appliance safety valves outlet must be connected to a tundish.
Otherwise, the appliance's manufacturer declines any responsibility in case of flooding if the drain valves cut.

The current technical standards in force prescribes the washing and treatment of the water in the heating and water system, in order to protect the system and the appliance from deposits (e.g. scale), slurry or other hazardous deposits.

Water connections must be made in a rational way using the couplings on the Indoor Unit template.



The manufacturer declines all liability in the event of damage caused by the installation of an automatic filling system.

In order to meet the system requirements established by EN 1717 in terms of pollution of drinking water, we recommend installing the IMMERGAS anti-backflow kit to be used upstream of the cold water inlet connection of the Indoor Unit. We also recommend using category 2 heat transfer fluid (ex: water + glycol) in the Indoor Unit primary circuit (heating and/or cooling circuit), as defined in standard EN 1717.

Make the hydraulic connection by placing the filter (pos. 2), the flow limiter (pos. 3) and the non return valve (pos. 4) on the cold water infeed tube as shown in the figure 5.

Also install the "Y" filter (pos. 1) on the system return pipe as shown in figure 5.

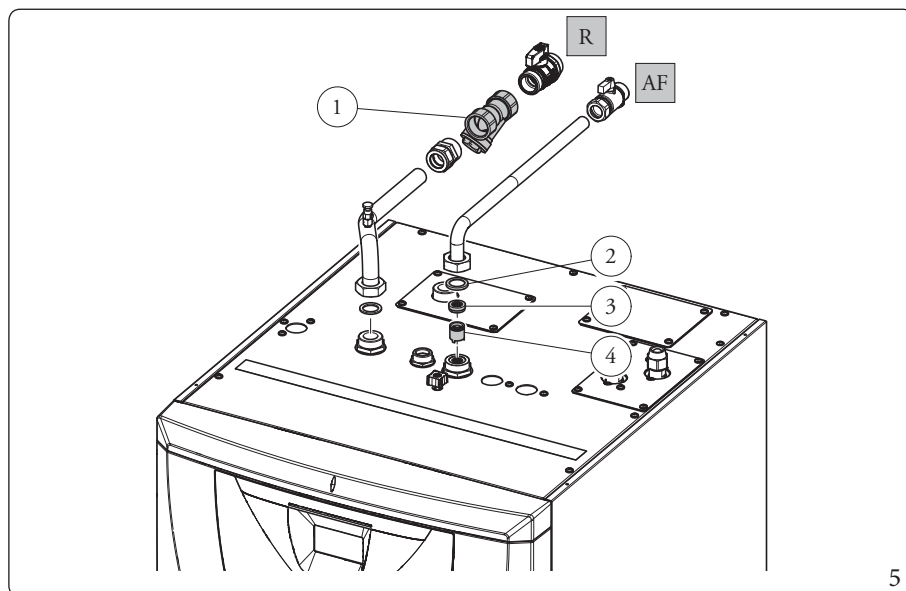

Key (Fig. 5):

- 1 - Filter
- 2 - Sealed filter
- 3 - Flow limiter
- 4 - Non return valve

- AF - 3/4" Domestic cold water inlet
- R - 1" system return



In order to preserve the proper functioning of the manifold within the hydraulic circuit, it is necessary for the inspection Y-filter (pos. 1, Fig. 5) to work in a horizontal position.



1.7 CONNECTING THE CHILLER LINE

As far as connecting the chiller line is concerned, all the instructions contained in the outdoor unit instructions booklet must be followed.

Make the connections directly on the indoor unit couplings (Pos. 1 and 2, Fig. 6).

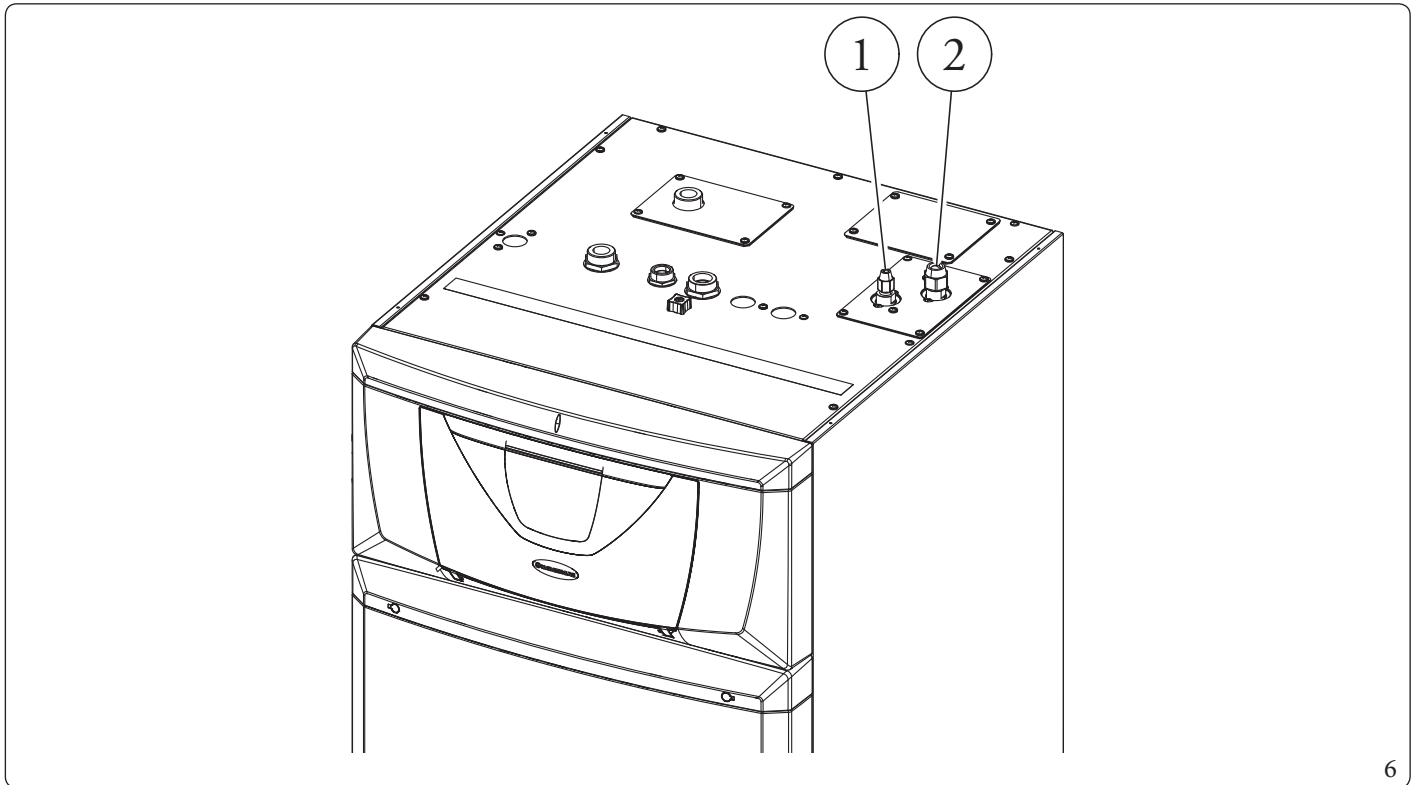

6

INSTALLER

USER

MAINTENANCE/TECHNICIAN

TECHNICAL DATA



1.8 ELECTRICAL CONNECTION

Indoor unit electrical connection

The internal unit has an IPX5D degree of protection; electrical safety of the appliance is achieved only when it is properly connected to an efficient earthing system, as specified by current safety standards.



The manufacturer declines any responsibility for damage or physical injury caused by failure to connect the Indoor Unit to an efficient earthing system or failure to comply with the IEC reference standards.

Connections are provided to both the control panel (Fig. 15) and the main panel (Fig. 16).

Main panel opening

To open the main panel, simply follow the instructions below:

1. Remove the protection caps (a) and loosen the screws (b) to remove the aesthetic profile (c) (Fig. 7).
2. Open the cover door (f) to make it tilt. Remove the protection caps (d), loosen the two upper front screws and the lower screws (e) to remove the cover (f) (Fig. 8).

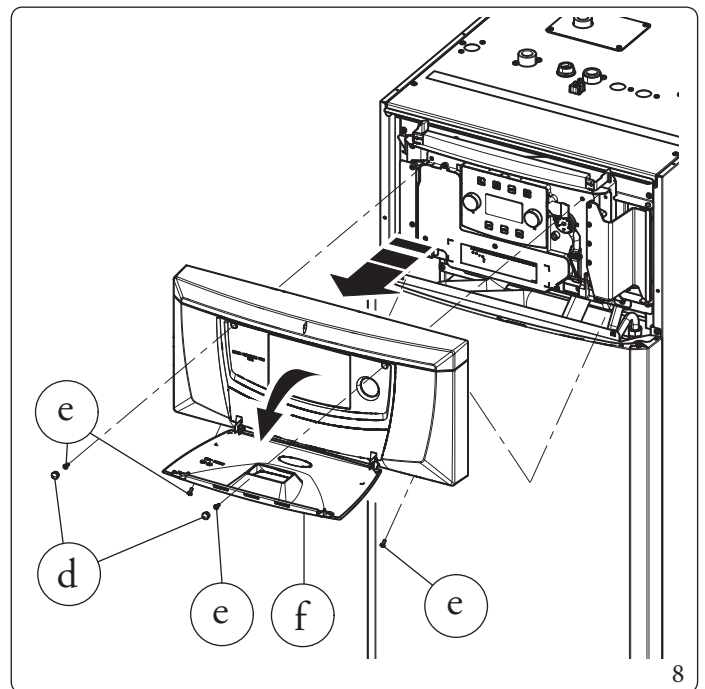
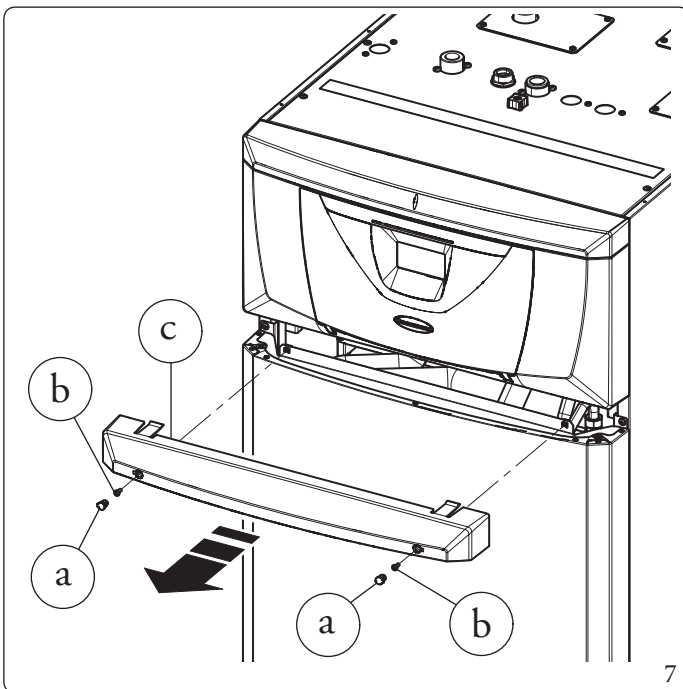

3. Unscrew the screws (g) (Fig. 9).
4. Open the main panel as shown in figure 10.

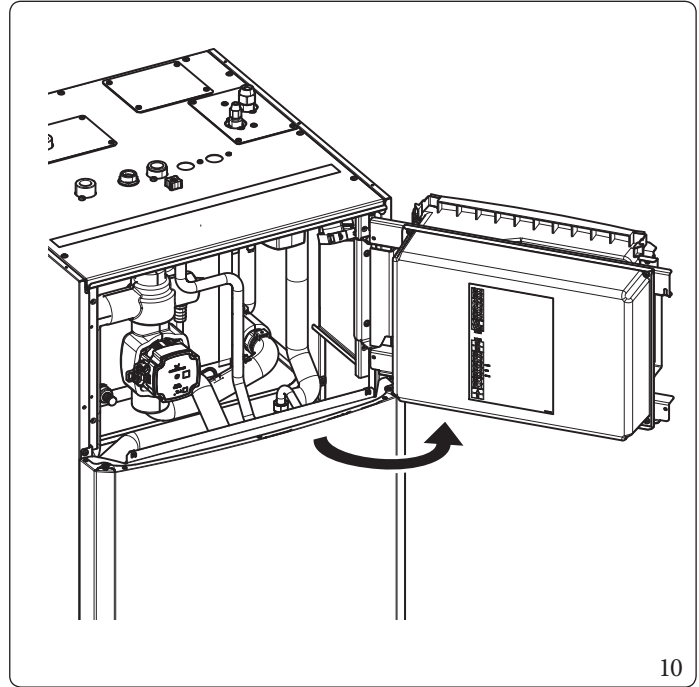
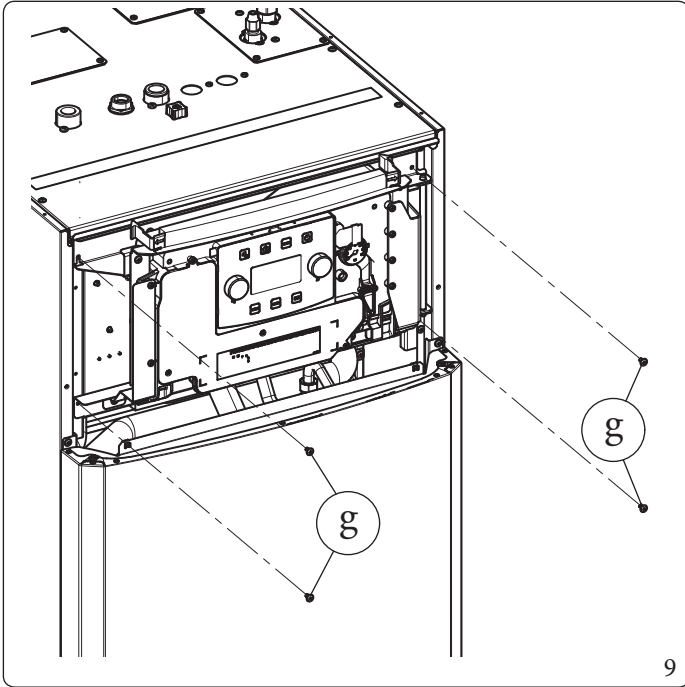

5. Undo the screws (h) and remove the cover (i) (Fig. 11).

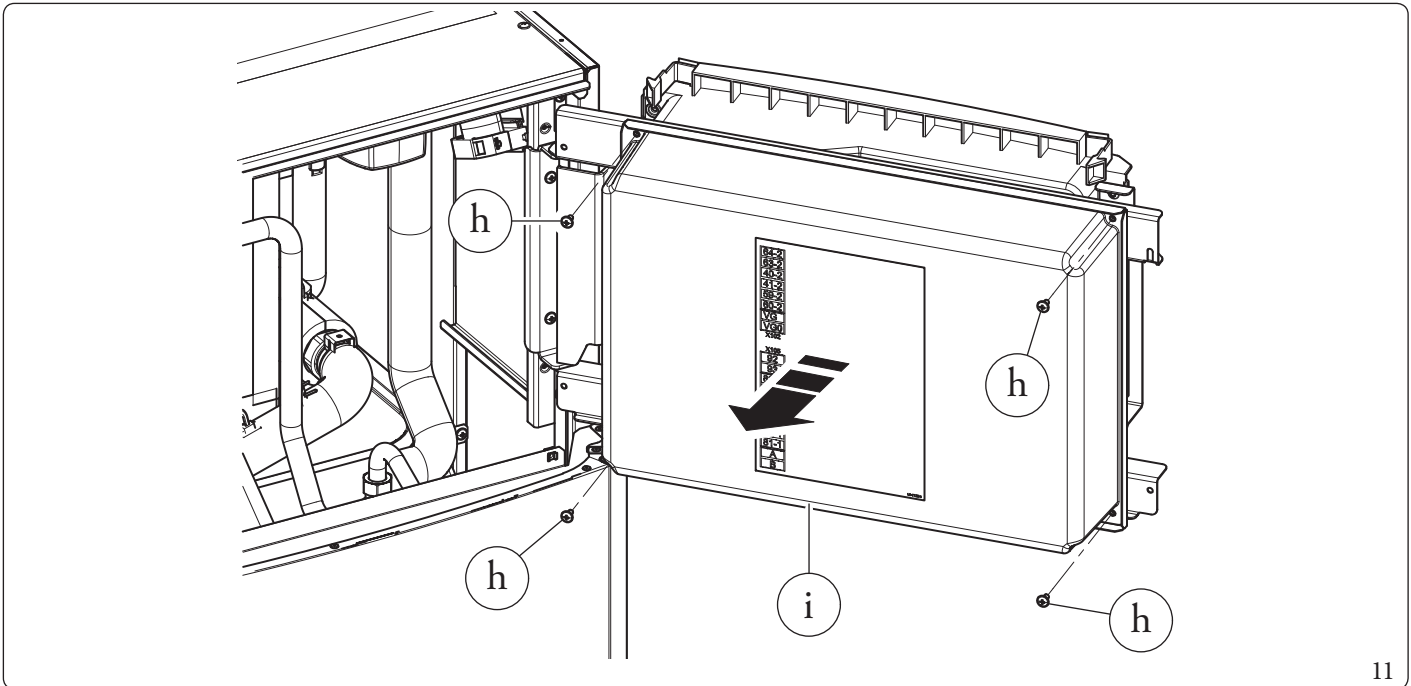

Ensure that the electrical installation corresponds to maximum absorbed power specifications as shown on the indoor unit data nameplate.

Indoor units are supplied complete with an "X" type power cable (l, Fig. 12) without plug.

If a longer power cable is required, choose one with an adequate cross-section based on the rated current value indicated in the table "Indoor Unit data" on page 112 and according to the provisions of technical legislation and standards.

The device is equipped with two fuses:

- Control phase fuse (F1, Fig. 43): 3,15A F 250 V 5x20;
- Phase fuse for DHW integrative resistance (F2, Fig. 43): 12 A aM 500V CH10.

If fuses in the main electrical panel are to be replaced, this must also be done by qualified personnel.



The power supply cable (1) must be laid as shown (Fig. 12).

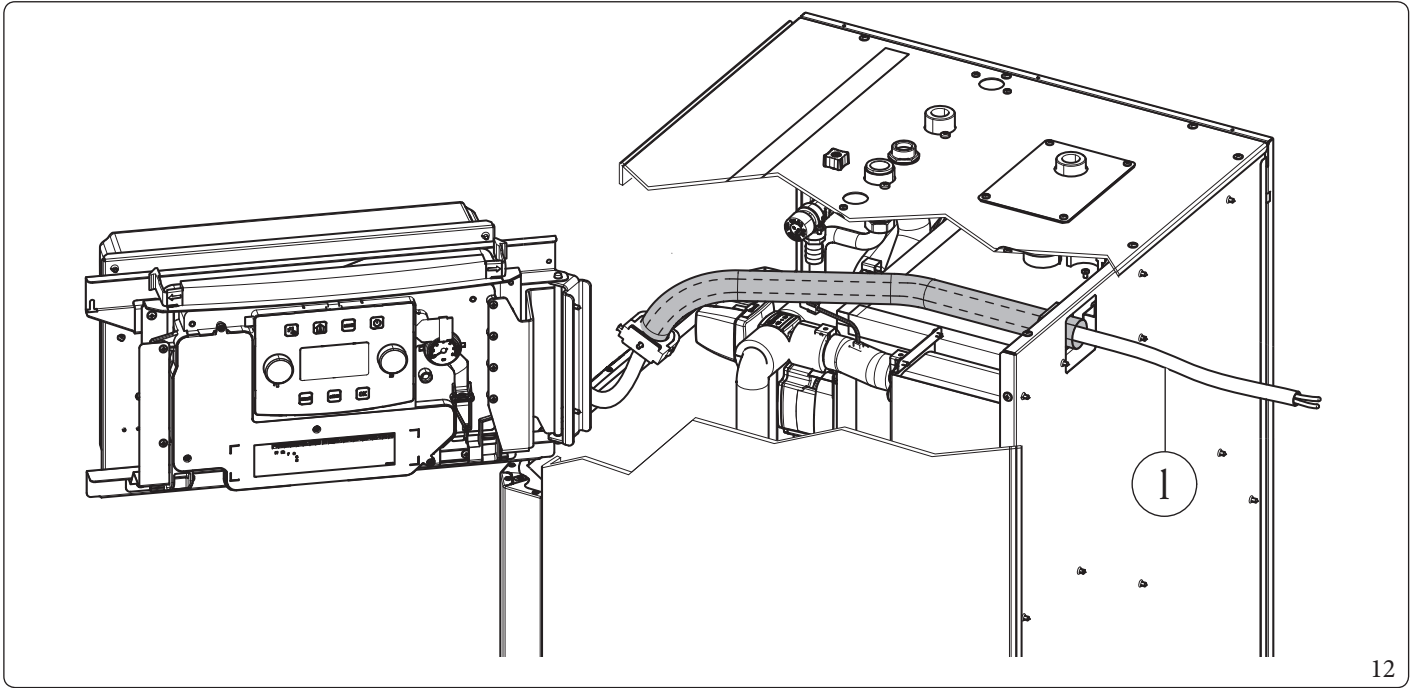

12



It is recommended to contact a qualified company (e.g. the Authorised After-Sales Technical Assistance Centre) for replacement to avoid a hazard.



To protect from possible dispersions of DC voltage, it is necessary to provide a type A differential safety device.



The power supply cable must be connected to a 230V $\pm 10\%$ / 50Hz mains supply respecting L-N polarity and earth connection; this network must also have a multi-pole circuit breaker with class III overvoltage category in compliance with installation regulations.



An overcurrent limiting device with tripping curve "C" suitable for the maximum currents declared in chapter "Technical data" should be provided to protect against any overcurrent.



The connection cables to the X105 terminal block of the main panel (optional components) must follow the same path as the power cable (1, fig. 12)



To avoid the possible interference of communication signals, the connection cables to the X102 terminal board of the main panel and those made on the X108 and X109 terminal blocks of the control panel must be separated from the power cables and secured outside the corrugated duct of the power supply cable (1, fig. 12) using the specific openable cable ties supplied with the product.

Electrical connections to the main panel

The electrical connections available are:

- Zone 2 flow probe;
- Zone 2 humidistat;
- Zone 2 thermostat;
- Optional external system integrative resistances;
- Multifunction relay kit;
- Zone 1 pump;
- Zone 2 pump;
- Zone 2 Mixing Valve;
- Power connection of the expansion kit.

The connection cables must follow the predetermined path using the special cable glands (a) (Fig.13).

Key (Fig. 13):

- 1 - Internal system resistance connection (E16-A1)
- 2 - Three-way connection (M30)
- 3 - Pump connection (M1)
- 4 - Storage tank probe connection
- 5 - DHW (Domestic hot water) resistance connection (E15)
- 6 - Heat pump return probe connection
- 7 - Flow meter connection (B25)
- 8 - Main electrical panel connections
- 9 - Connection between the control panel and main panel
- 10 - Liquid phase probe connection
- 11 - Heat pump flow probe connection
- a - Cable gland

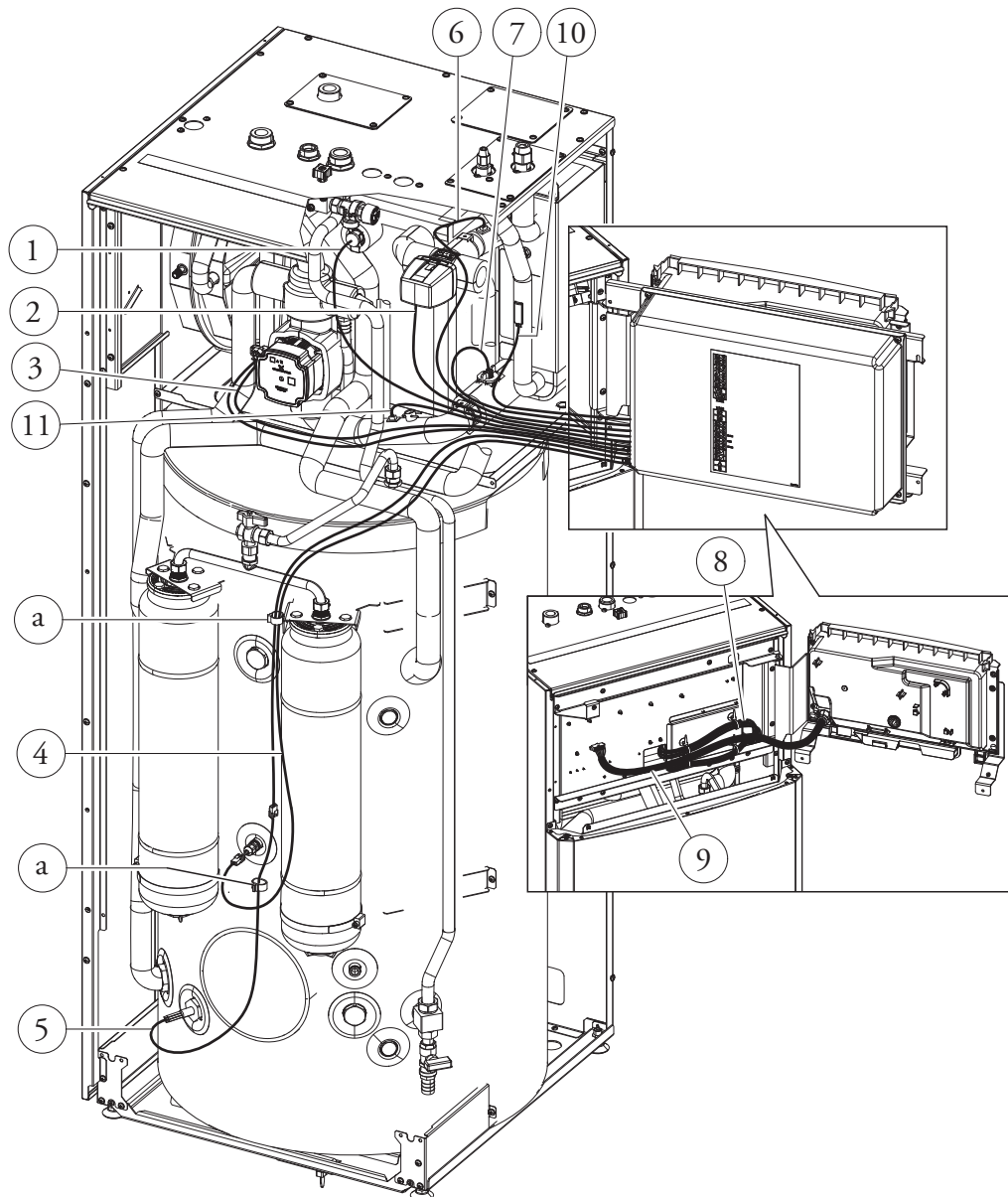

13

INSTALLER

USER

MAINTENANCE TECHNICIAN

TECHNICAL DATA



Open the control panel connections compartment (Fig. 14).

To carry out electrical connections, all you have to do is open the connections compartment as follows.

1. Remove the cover and the aesthetic profile.
2. Disassemble the cover.
3. Loosen the screws (a).
4. Remove the cover (b) from the control panel (c).

At this point, you can access the terminal board.

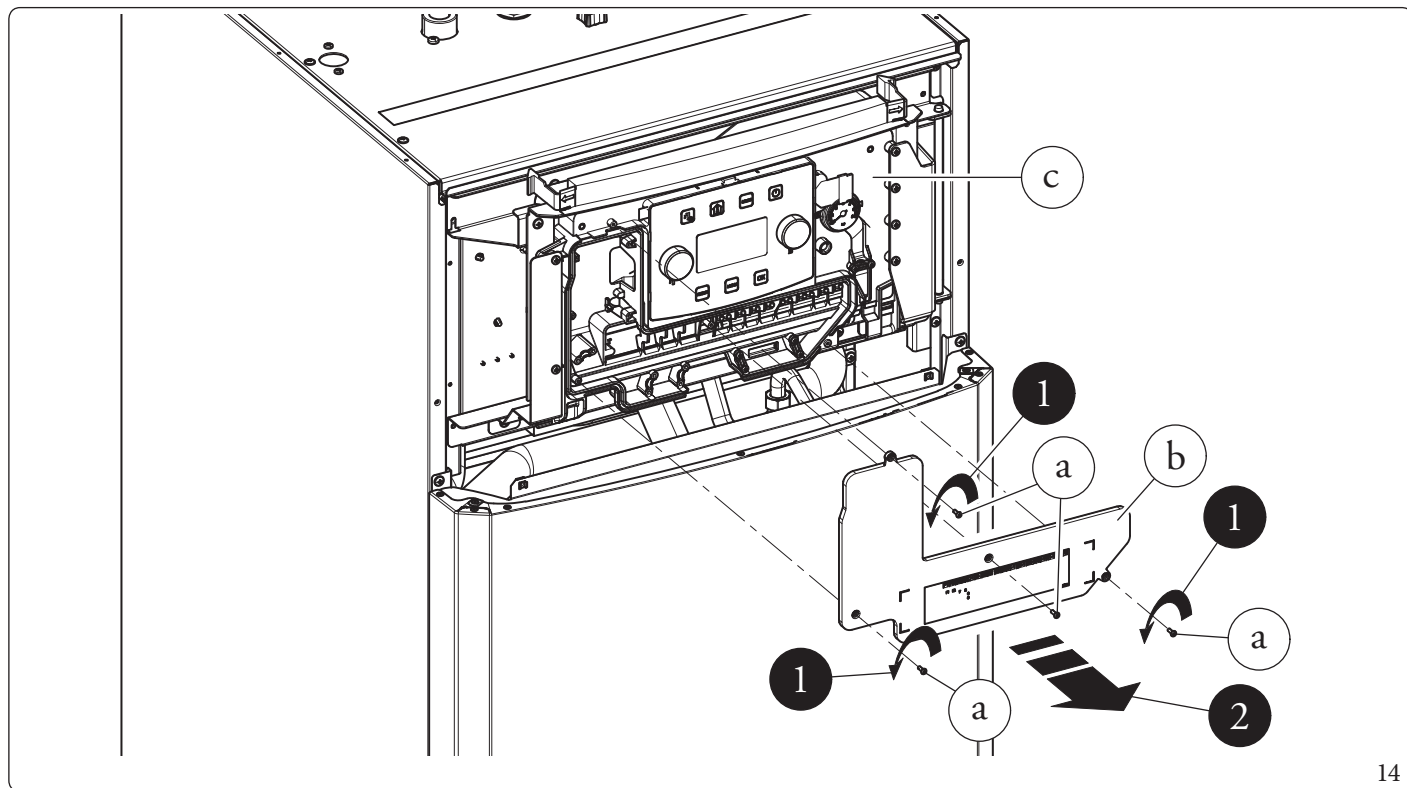

14

Electrical connections to the control panel

The electrical connections available are:

- Photovoltaic system: connecting the product to a photovoltaic system enhances use of the outdoor unit when the photovoltaic panels are operating.
- Dehumidifier zone 1.
- Zone 1 flow probe.
- Zone 1 humidistat.
- Zone 1 thermostat.
- Zone 1, 2 and 3 remote devices (Zone remote panel or Temperature/humidity probe), Dominus, ModBus communication expansion kit.
- External probe or alternatively DHW recirculation probe
- Heat pump disabling.
- Heat pump communication.

Connections must be made on the terminal board inside the control panel (Fig. 15) for zone 1 or in the main panel of the appliance (Fig. 16) for zone 2.

Outdoor unit electrical connection

The indoor unit must be coupled to an outdoor unit by connecting terminals F1 and F2 as shown in the wiring diagram (Fig.16). The outdoor unit is powered at 230 V~, independently of the indoor unit.

Configure the parameter "HP Model" as indicated in the paragraph (Par. 3.9) according to the type of connected outdoor unit.

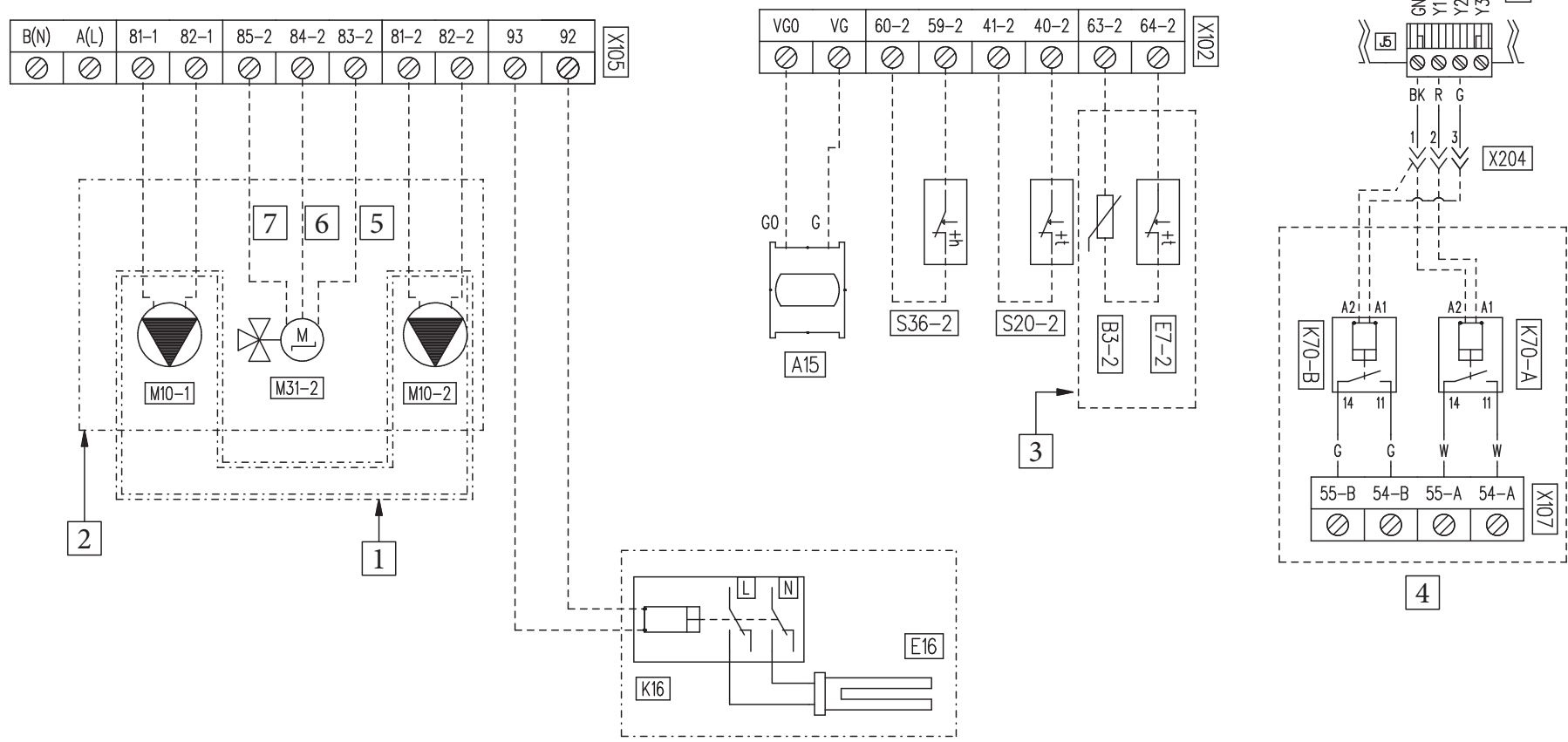

Key (Fig. 15):

- | | | | |
|----------|---|----|--------------------------------------|
| A13 | - Supervision board | 1 | - 2 direct zones kit |
| A15 | - Electronic expansion board (optional) | 2 | - 2 zones kit (1 mixed and 1 direct) |
| B3-2 | - Zone 2 flow probe (optional) | 3 | - 2 zones kit (1 mixed and 1 direct) |
| E7-2 | - Zone 2 safety thermostat (low temperature) (optional) | 4 | - Dual-relay kit |
| E16 | - System integration resistance (optional) | 5 | - Closed |
| K16 | - System integration resistance relay (optional) | 6 | - Common |
| K70-A, B | - Multifunction relay (optional) | 7 | - Open |
| M10-1 | - Zone 1 circulator pump (optional) | BK | - Black |
| M10-2 | - Zone 2 circulator pump (optional) | G | - Green |
| M31-2 | - Zone 2 mixing valve (optional) | R | - Red |
| S20-2 | - Zone 2 room thermostat (optional) | W | - White |
| S36-2 | - Zone 2 humidistat (optional) | | |



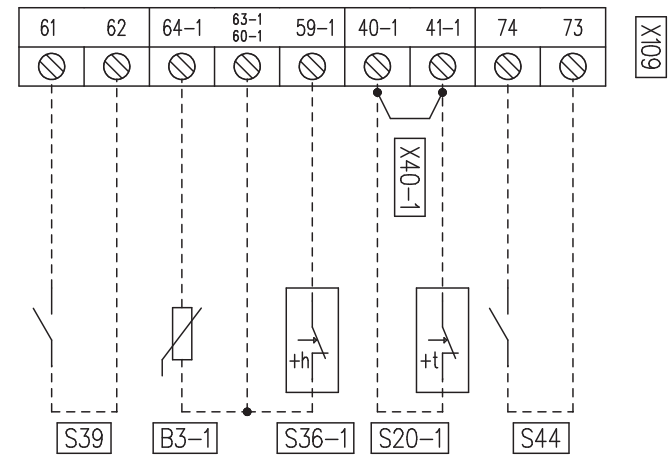
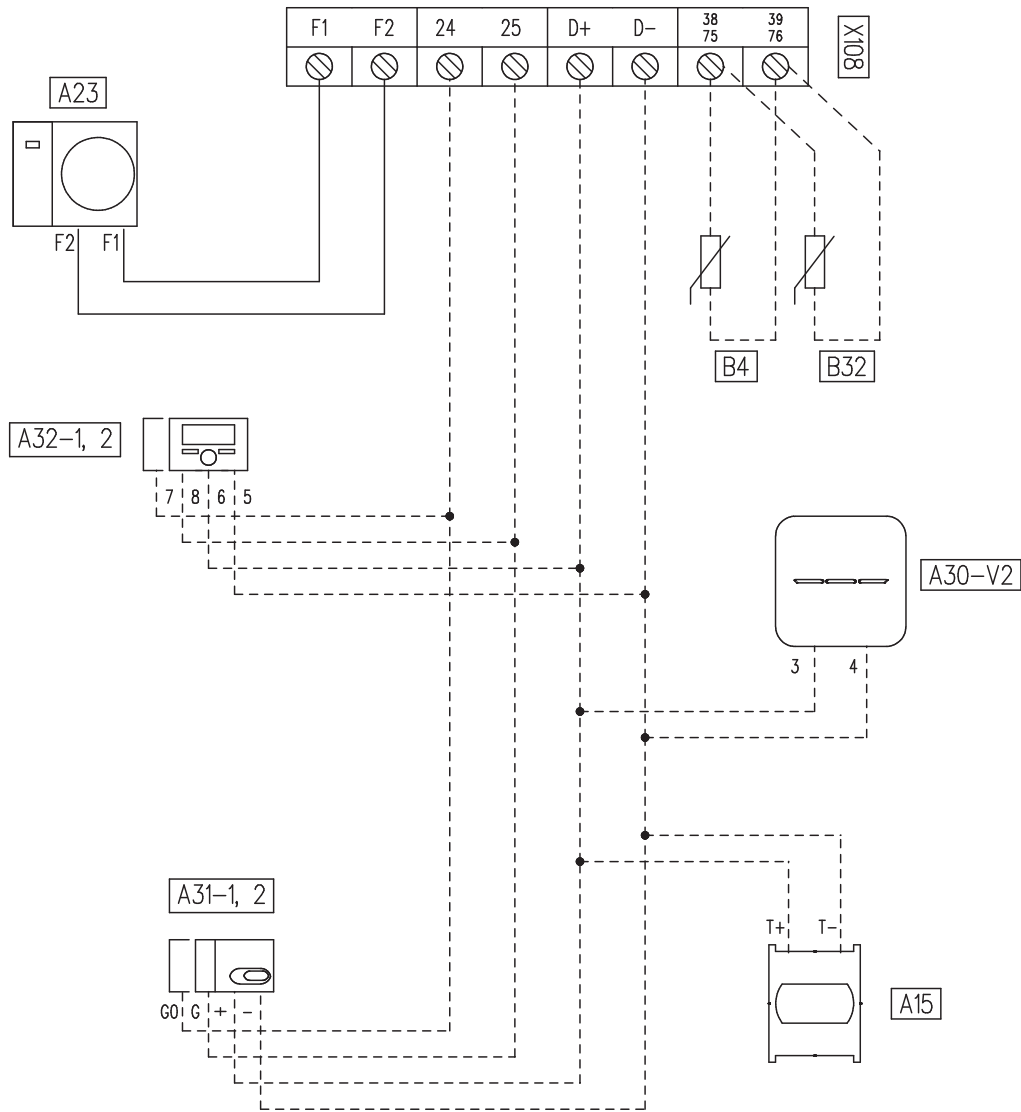

Key (Fig. 16):

- A15 - Electronic expansion board (optional)
- A23 - Outdoor unit
- A30-V2 - Dominus V2 (optional)
- A31-1, 2 - MODBUS temperature sensor zone 1, 2 (optional)
- A32-1, 2 - Zone 1, 2 remote panel (optional)
- B3-1 - Zone 1 flow probe (optional)
- B4 - External probe (optional)
- B32 - Recirculation probe (optional)
- S20-1 - Zone 1 room thermostat (optional)
- S36-1 - Zone 1 humidistat (optional)
- S39 - Photovoltaic inlet (optional)
- S44 - Heating/Cooling Selector (optional)
- X40-1 - Zone 1 room thermostat link



1.9 REMOTE ZONE CONTROL (OPTIONAL)

This remote device is used to adjust the setpoints and to view the main information of the zone where it was configured.

Make the connection to the appliance as shown (Fig. 16) and leave the link on terminals 40-1/41-1 for zone 1 and terminals 40-2/41-2 for zone 2.

To correctly configure the device, set the parameters as described below:

Assistance Menu -> Device configuration	
Slave address: Address to configure according to the zone where the device is installed	Zone 1 = 41
	Zone 2 = 42
	Zone 3 = 43
Baud Rate	9600
Parity bit	Even
Stop bits	1
Heat pump control	NO

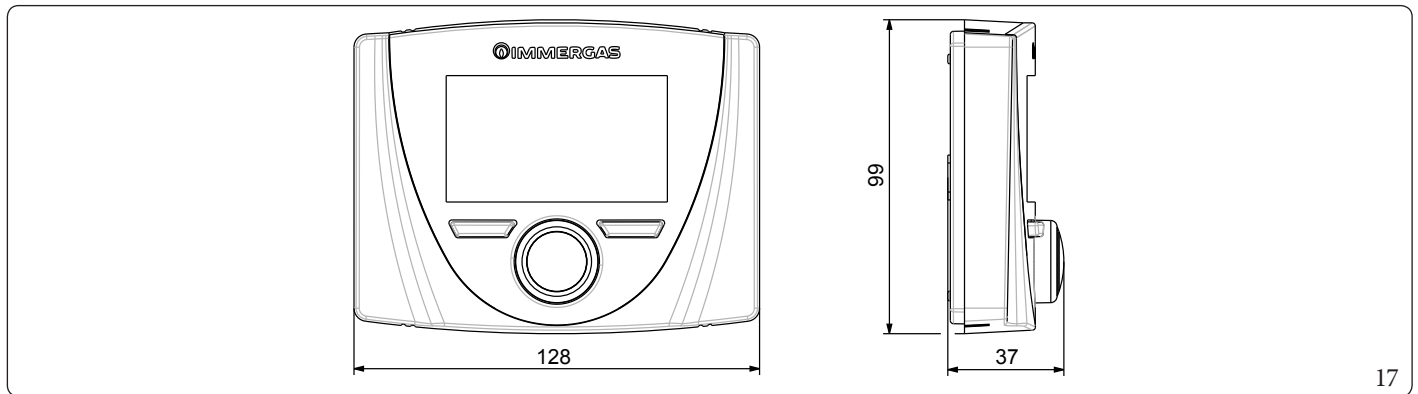

INSTALLER

USER

MAINTENANCE TECHNICIAN

TECHNICAL DATA



1.10 MODBUS TEMPERATURE AND HUMIDITY ROOM PROBES (OPTIONAL)

The Modbus temperature and humidity probe is used to detect the room temperature and humidity and to calculate the dew point. In addition, by setting the relative zone room setpoints available on the Control panel (see 2Par. 2.6), it is possible to check the temperature and humidity of a room.

Make the connection to the appliance as shown (Fig. 16) and set the DIP-switches on the probe.

DIP-Switch configuration table

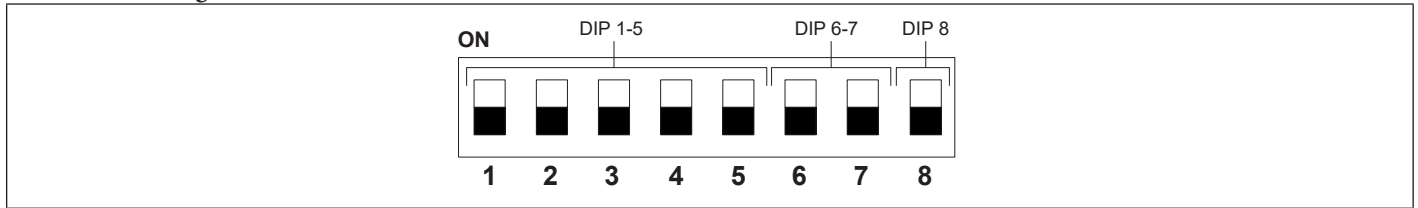

DIP 1-5 (Address)		Zone 1 (Address 131)
		Zone 2 (Address 132)
		Zone 3 (Address 133)
DIP 6-7 (Type)		Modbus 1-8-E-1
DIP 8 (Speed)		9600 bit/s

1.11 ROOM CHRONO-THERMOSTATS (OPTIONAL)

The Indoor Unit is prepared for the application of room chrono-thermostats, which are available as optional kits. A maximum of 3 temperature controllers can be applied directly to the appliance. All Immergas chrono-thermostats are connected with 2 wires only. Carefully read the user and assembly instructions contained in the accessory kit.



Disconnect power to the unit before making any electrical connections.

On/Off Immergas digital chrono-thermostat.

The chrono-thermostat allows:

- set two room temperature value: one for day (comfort temperature) and one for night (reduced temperature);
- set a weekly programme with four daily switch on and switch off times;
- selecting the required function mode from the various possible alternatives:
 - manual mode (with adjustable temperature);
 - automatic mode (with set programme);
 - forced automatic operation (momentarily changing the temperature of the automatic program).

The chrono-thermostat is powered by two 1.5V LR6 type alkaline batteries.

On/Off chrono-thermostat electrical connection (Optional).



The operations described below must be performed after having removed the voltage from the appliance.

On/Off ambient thermostat or chrono-thermostat: must be connected to the 40-1 / 41-1 terminals, eliminating the X40-1 jumper for zone 1, 40-2 / 41-2 for zone 2 and U4 / U5 for zone 3 (optional expansion kit).

Make sure that the On/Off thermostat contact is of the “clean” type, i.e. independent of the mains voltage, otherwise the P.C.B. would be damaged.

The connections must be made on the terminal board inside the control panel (Fig. 15) or the appliance’s main panel (Fig. 16).



If any On/Off chrono-thermostat is used, arrange two separate lines in compliance with current regulations regarding electrical systems.

No indoor unit pipes must ever be used to earth the electric system or telephone lines.

Ensure elimination of this risk before making the indoor unit electrical connections.

1.12 HUMIDISTAT ON/OFF (OPTIONAL)

You can make a dehumidification demand by using a humidistat.

Connections must be made on the terminal board inside the control panel (Fig. 15) for zone 1 or in the main panel of the appliance (Fig. 16) for zone 2.

1.13 DEHUMIDIFIERS (OPTIONAL)

To use the dehumidification function required during the cooling function in the radiant systems, it is possible to install dehumidifiers and control them directly from the management board by installing the 2-relay kit (optional). Connect as shown in the kit’s instructions sheet.

With the installation of a Immergas dehumidifier, it is possible to activate either the dehumidification function in neutral air or in cooled air (see dehumidifier kit manual for more details on the function).



1.14 EXTERNAL TEMPERATURE PROBE (OPTIONAL)

An external probe is installed in the outdoor unit as per standard.

The external probe is used to:

- Thermoregulate the water flow temperature;
- Determine the use of additional generators (electrical resistances).

If the outdoor unit is positioned in an area that is not suitable for temperature reading, it is advisable to use an additional external probe (Fig. 18) which is available as an optional kit.

Refer to the relative instruction sheet for positioning of the external probe.

For the proper operation of the optional probe, it must be electrically connected where envisaged (Fig.16) and then enabled (Par. 3.26)

The presence of the external probe allows the system flow temperature to be set automatically based on the outdoor temperature in order to adapt the heating or cooling provided to the system.

The system flow temperature is determined by the setting on the "Zones" menu and by the "User" menu for the offset values based on the curves shown in the diagram (Par. 1.16).



If the system is divided into two or three zones, the flow temperature is calculated based on the zone with the higher temperature in central heating mode and with the lower temperature in cooling mode.



If the optional external probe is used, the DHW recirculation function cannot be used.

In the event of a failure of the optional external probe, after switching it off and back on, the outside temperature is automatically detected by the external probe on the outdoor unit.

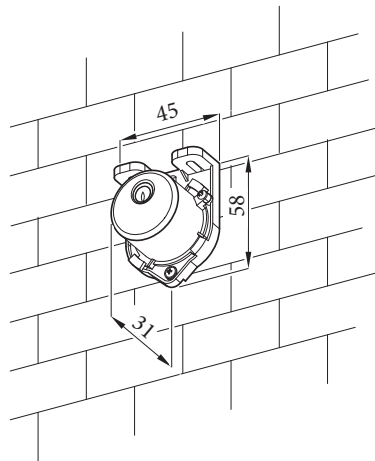

18

1.15 DOMINUS (OPTIONAL)

The system can be remote controlled using the optional Dominus kit.

Connect the appliance as shown (Fig. 16).

The following is necessary to enable Dominus:

- position the Dip Switches: OFF-OFF-OFF-ON;
- set the parameter on the control panel **System supervision = Domin**;
- configure the Dominus APP profile on Magis Hercules Pro Mini EH.



The Dominus firmware must be updated to at least revision 2.02.

For further information, consult the relative instruction sheet.

1.16 TEMPERATURE CONTROL SETTING

By setting the parameters in the menus

Zones/Configuration

it is possible to automatically adjust the flow temperature of each zone according to the outdoor temperature. This can be done by enabling the external probe modulation in the menu

Zones/Enablings

The curves (Fig. 19, 20, 21, 22) show the default settings in the various operating modes available both with external probe and without.

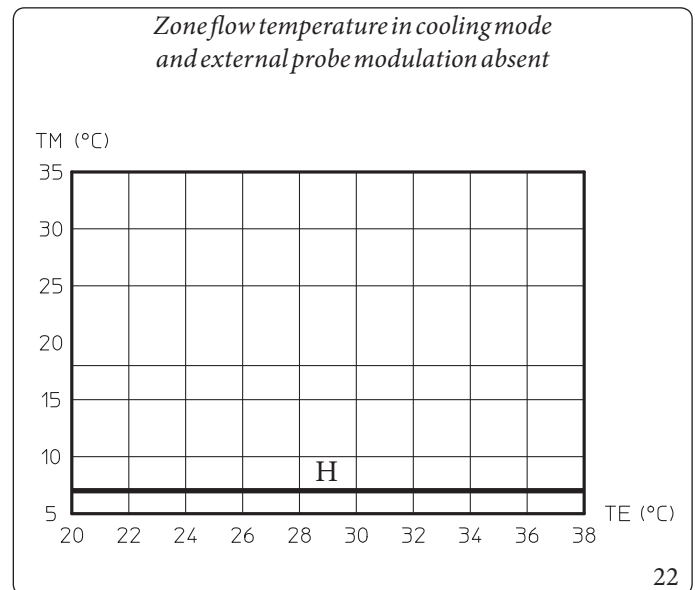
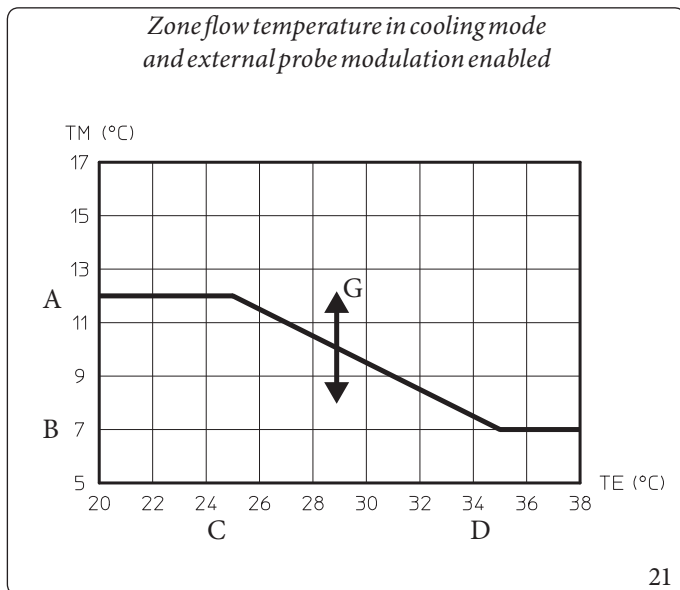
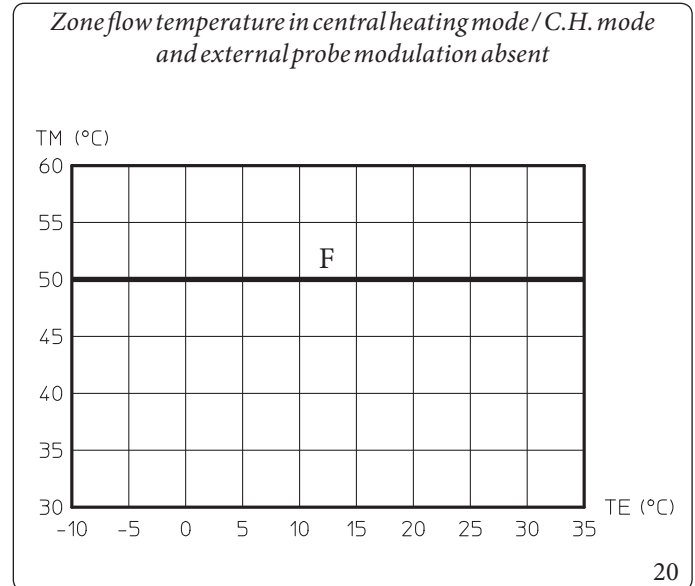
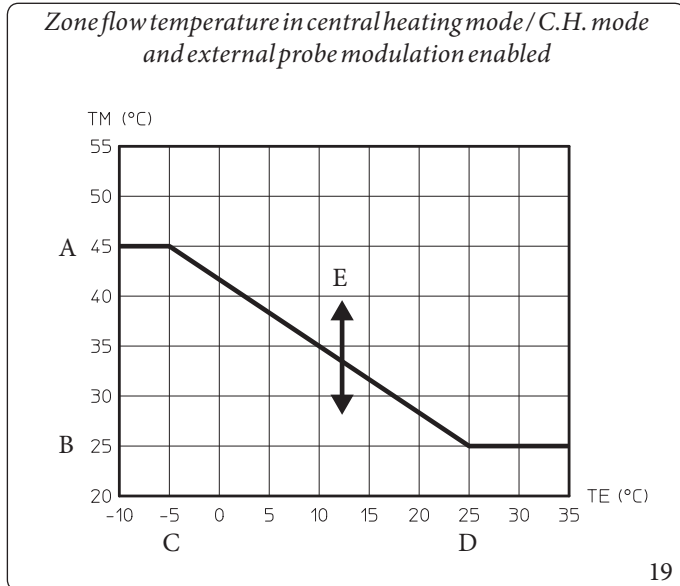

Key (Fig. 19, 20, 21, 22)

- A - Maximum flow set
- B - Minimum flow set
- C - External minimum temperature
- D - External maximum temperature

- E - C.H. flow temperature offset
- F - Central heating / C.H. flow set
- G - Cooling flow temperature offset
- H - Cooling flow set



1.17 SYSTEM FILLING

Once the indoor unit is connected, fill the system using the filling valve (7, Fig. 30).

The indoor unit has incorporated an automatic air vent valve on the internal inertia manifold.

It is also necessary to provide a vent at the highest point of the heat pump return branch. With the installation of the optional connection unit, a manual deaerator is provided.



Make sure that the hoods are loosened.

The filling valve must be closed when the indoor unit pressure gauge indicates approximately 1.2 bar.



During these operations, enable the manual "De-aeration" functions, which lasts about 18 hours (Parag. 3.9).

1.18 OPERATING LIMITS

The appliance was designed to work in a specific range of outdoor temperatures and at a specific maximum flow temperature. The chart (Fig. 23, 24, 25) shows these limits.

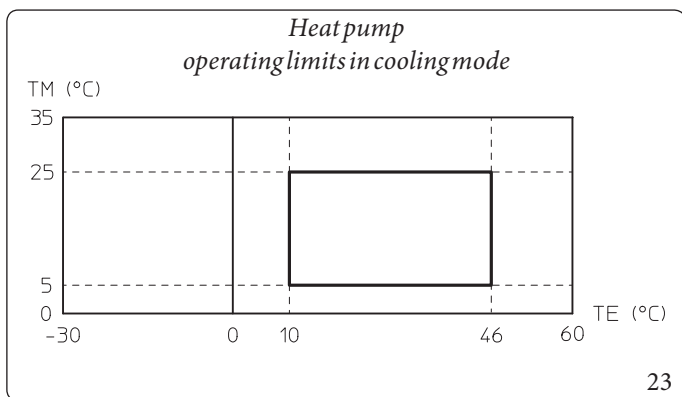

Key (Fig. 23):

TE = External temperature

TM = Flow temperature

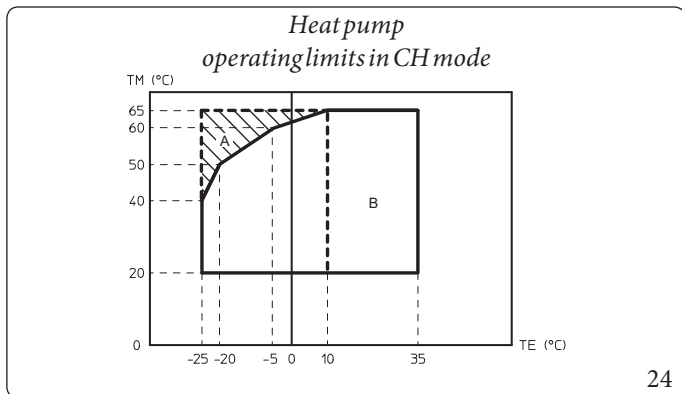

Key (Fig. 24):

TE = Temperatura esterna

TM = Flow temperature

A = Con resistenza elettrica impianto

B = Without electrical resistance enabled

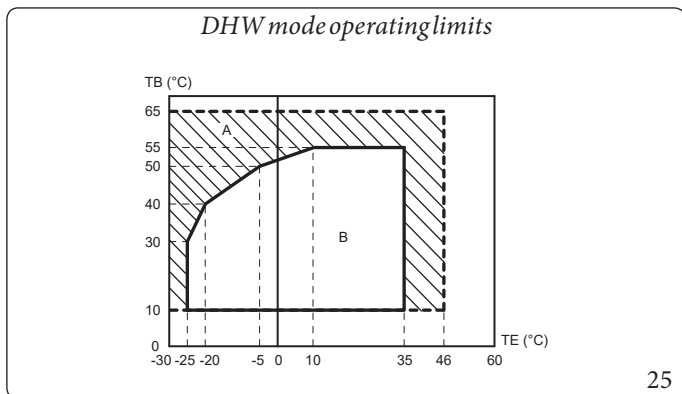

Key (Fig. 25):

TE = External temperature

TB = Storage tank temperature

A = With integration electrical resistance

B = Without electrical resistance enabled



1.19 INDOOR UNIT START-UP (IGNITION).

After having installed the chiller lines on the Outdoor Unit, to commission the heat pump (the operations listed below must only be performed by qualified personnel and in the presence of staff only):

1. Check connection to a 230V~50Hz power mains, correct L-N polarity and the earthing connection;
2. Switch the indoor unit on and check correct ignition;
3. Check the intervention of the main switch located upstream from the indoor unit and in the indoor unit.
4. Set the first ignition parameters (Par. 3.10).



The system must not be started up if even only one of the checks should be negative.



After installation, check for leaks. Toxic gas could be generated if the unit comes into contact with a source of ignition, such as thermal fan, stove and cylinders. Make sure that only refrigerant recovery cylinders are used.



Apply the product data nameplate contained inside the warranty envelope, in an accessible and visible position. Use the serial number on this plate for THERMAL/GSE practices.



1.20 CIRCULATION PUMP

The appliance is supplied with a variable speed pump that adjusts the speed to ensure the best possible performance.

Pump LED.

The LED flashes green when the pump is powered and the control signal is connected.



The LED lights up steady green when the pump is powered and the signal cable disconnected. In these conditions the pump works at maximum speed and without control.

If the pump detects an alarm, the LED switches from green to red; this can mean one of the following failures:

- Low power supply voltage;
- Rotor seized;
- Electrical error.

For a detailed description of the meaning of the red LED, refer to the "Diagnostics in real time" table shown below.



The LED, in addition to being green or red, can also remain off.

It is normal for the LED to be off when the pump is not powered, whereas with the pump powered, the LED must be lit: if switched off, it means there is a fault.

Pump symbols (Fig. 26):

With the pump powered and the pwm control signal connected and operating (pump ON or in stand-by), the symbol 2 flashes green ().

If the symbol 2 turns steady green (), the pump detects no command on the pwm signal and always runs at maximum speed.

If the pump detects an alarm, symbol 1 lights up red (). This can mean that there is one of the following faults:

- Low power supply voltage.
- Rotor seized (Cautiously turn the screw in the centre of the head to manually release the motor shaft).
- Electrical error.

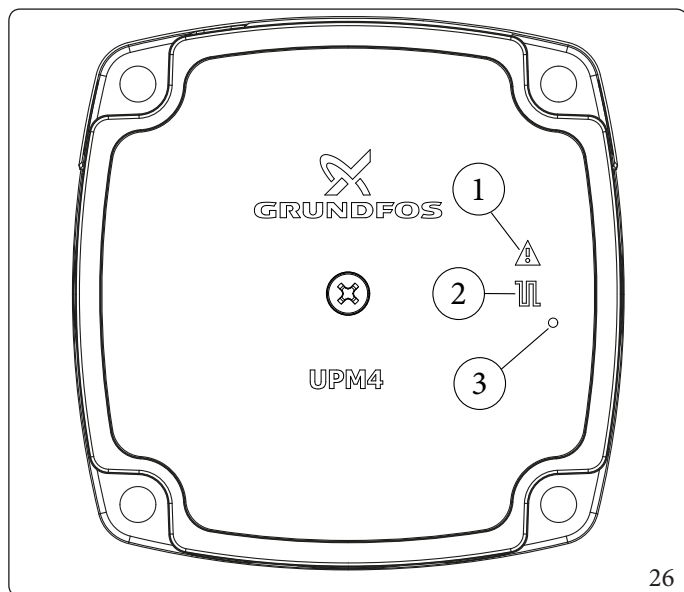

Key (Fig. 26):

- | | | |
|---|---|---|
| 1 | - | Alarm signal (Red) |
| 2 | - | Functioning status signal (Steady green/Flashing green) |
| 3 | - | Led (Not used on this model) |

Pump release.

If after a long period of inactivity, the circulator is blocked, adjust the screw in the centre of the head in order to manually release the motor shaft.

Take great care during this operation to avoid damage to the motor.



Head available to the system

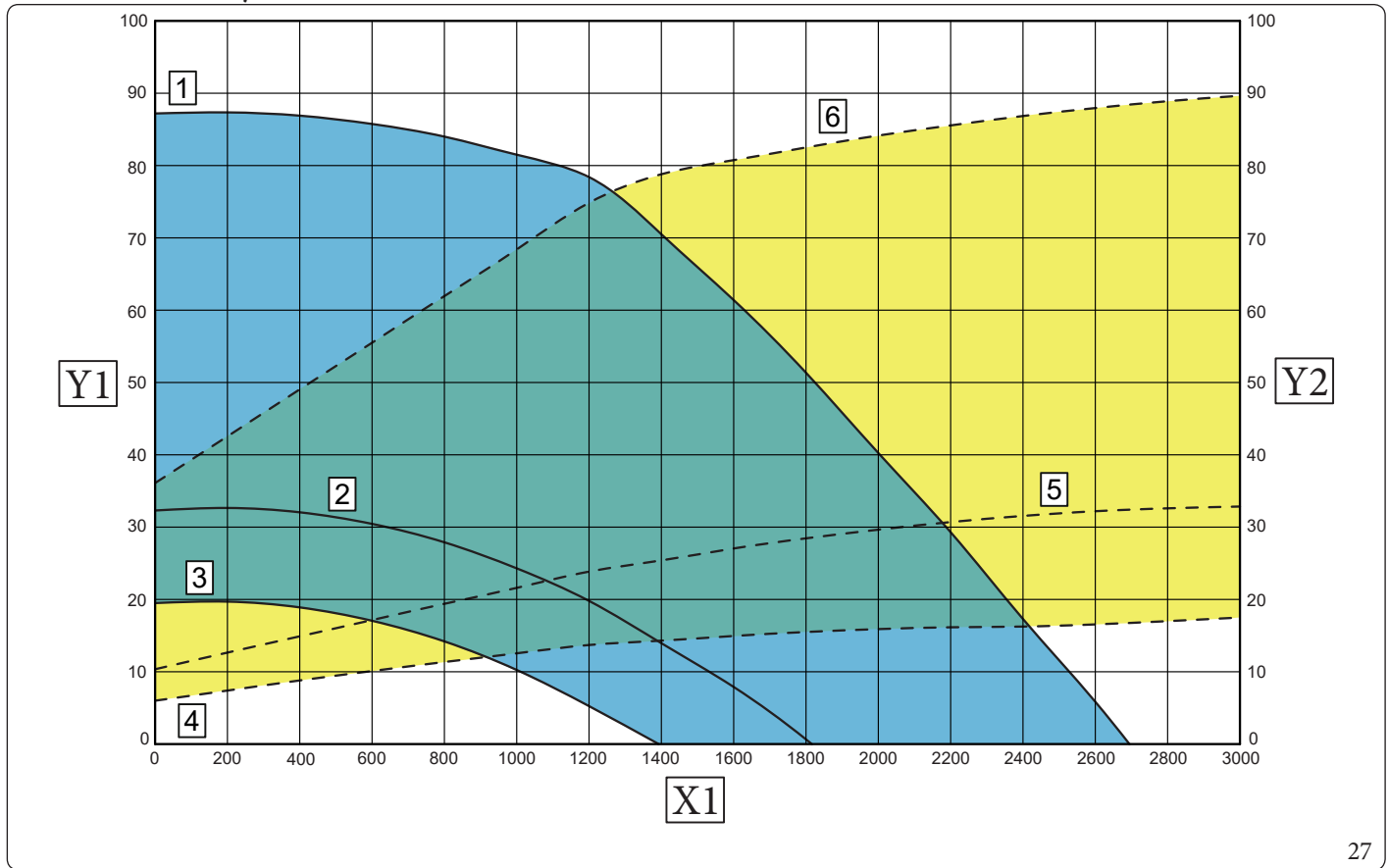

27

Key (Fig. 27):

- 1 = Head available to the PWM system 100%
- 2 = Head available to the PWM system 60% (minimum settable head for product with system integration resistance)
- 3 = Head available to the PWM system 50% (minimum settable head for product without system integration resistance)
- 4 = Power absorbed by pump PWM 50%
- 5 = Power absorbed by pump PWM 60%
- 6 = Power absorbed by pump PWM 100%
- X1 = Flow rate (l/h)
- Y1 = Head (kPa)
- Y2 = Circulator pump absorbed power (W)

INSTALLER

USER

MAINTENANCE TECHNICIAN

TECHNICAL DATA



1.21 DOMESTIC HOT WATER STORAGE TANK UNIT

The storage tank in the appliance is an accumulation type with a capacity of 180 litres.

It contains large coiled stainless steel heat exchanger pipes, which allow to notably reduce hot water production times.

These storage tank units constructed with stainless steel casing and bottoms, guarantee long duration through time.

The assembly concepts and welding (T.I.G.) are implemented to the minimum detail to ensure maximum reliability.

The side inspection flange ensures practical control of the storage tank unit and the coiled heat exchanger and easy internal cleaning.

The Magnesium Anode (11, Fig. 28) holder caps include the same, are supplied as standard for the internal protection of the storage tank from possible corrosion. These caps are positioned on the front of the storage tank (11, Fig. 28).

For easy maintenance or particular handling requirements, remove the storage tank as described below.

Storage tank disassembly (Fig.28).

- To disassemble the storage tank unit, empty the appliance system by acting on the relevant drain fitting. Before carrying out this operation, make sure that the system filling valves are closed.
- Close the cold water inlet valve and open any domestic hot water valve.
- Drain the storage tank by means of the draining valve (6).
- Loosen the nuts on the storage tank inlet pipes (5) and the cold inlet (7) and hot outlet (8) nuts on the storage tank (3). Loosen the nut (4) on the connection pipe to the DHW expansion vessel. Remove all freed pipes from their connection on the appliance.
- Unscrew the bracket screws (9) and remove the expansion vessels (10).
- Loosen the bracket (2) fixing screws (1) and remove the bracket itself.
- Slide the storage tank (3) to the front.

Work in reverse order to assemble the storage tank unit.

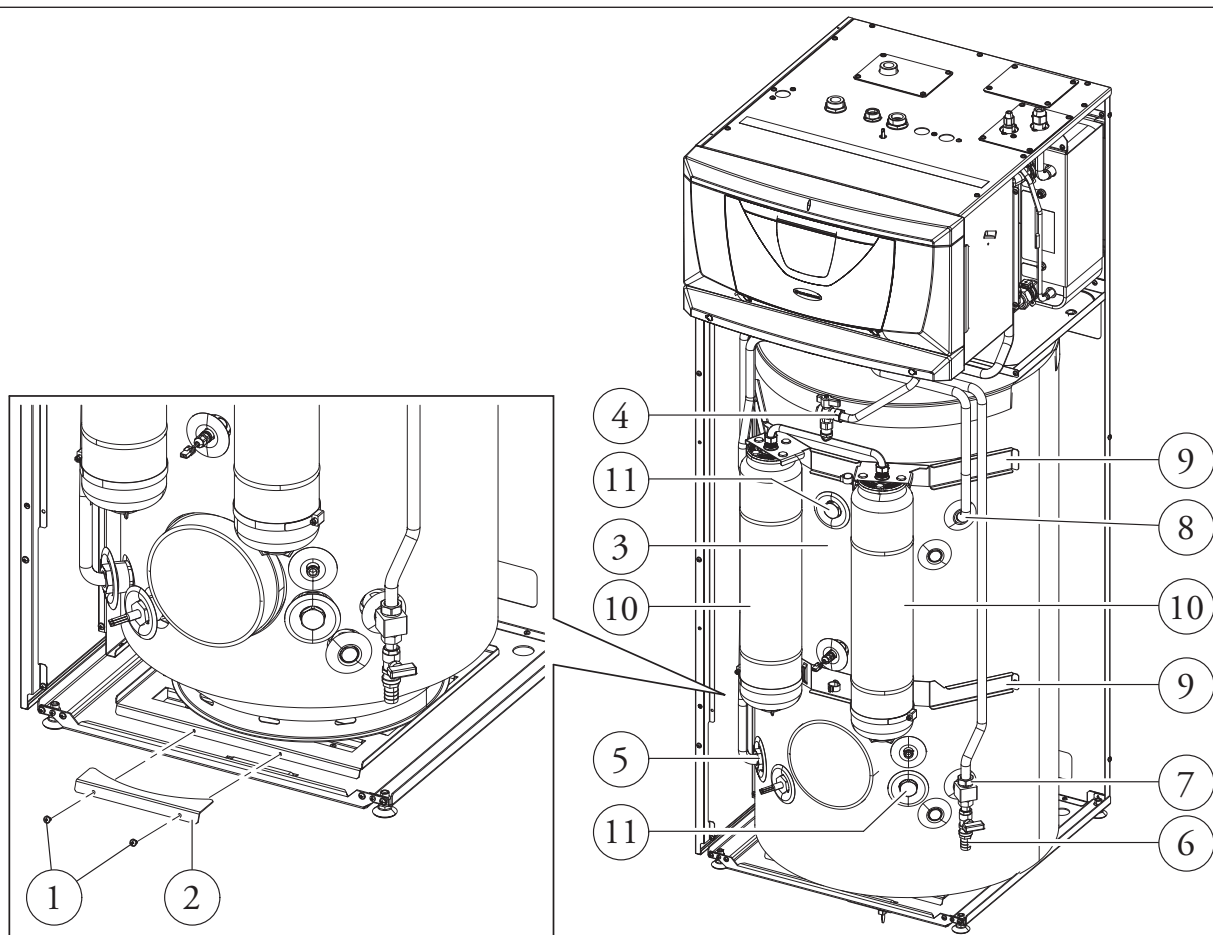

Condensate drainage present in the tray (Fig.29).

Under some operating conditions, condensate may form in the tray.

Make a drain hole on the ground towards the sewer system with an internal \varnothing of at least 22 mm and maximum \varnothing of 30 mm.

Connect the supplied flexible hose to the drainage elbow (1) and pull it out at the bottom of the unit as shown in figure 29 (pos. 2 or 3).

Make sure dust, debris and/or insects cannot enter this hose.

Also make sure that the liquid contained in it cannot freeze.

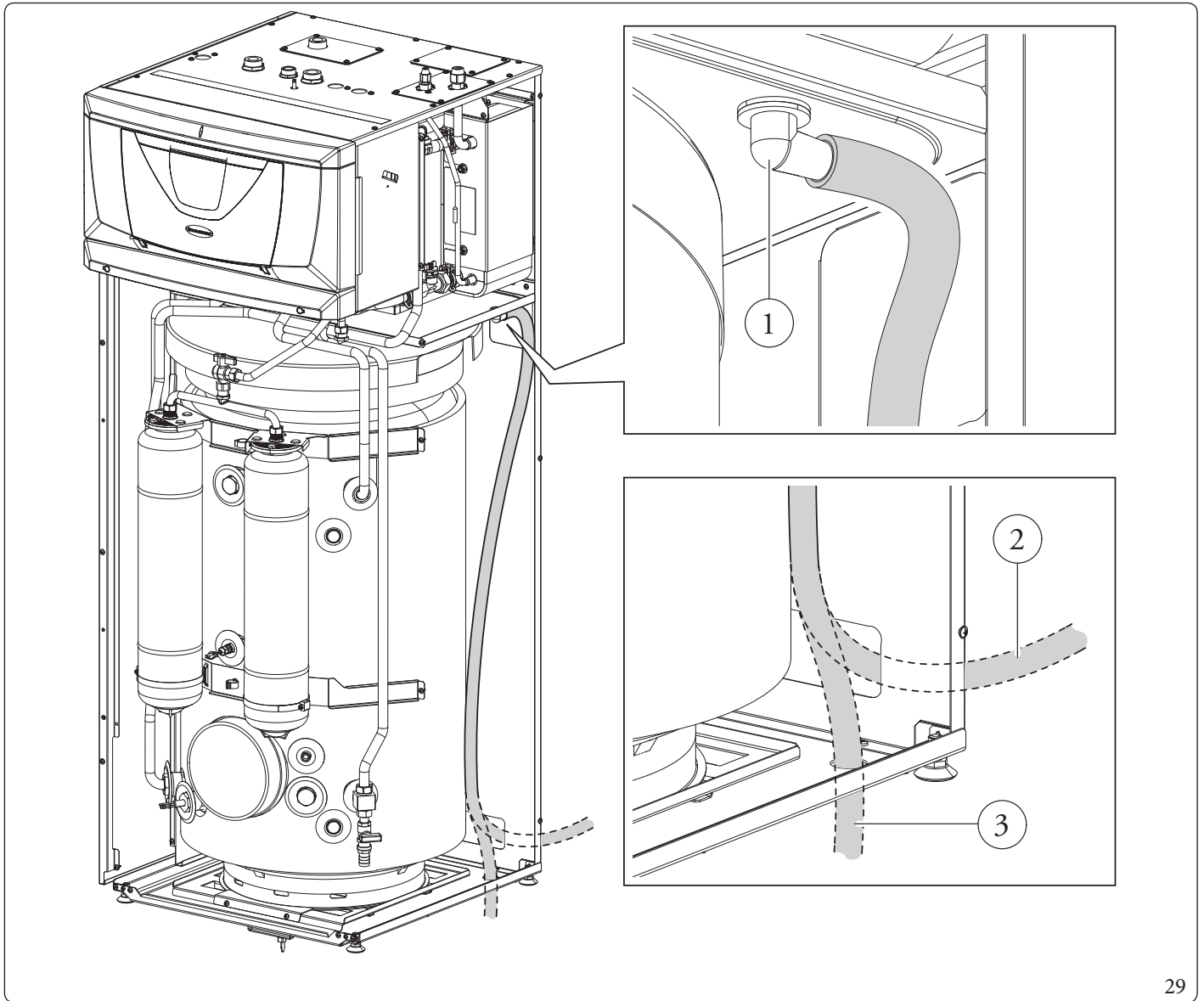

29

1.22 KITS AVAILABLE ON REQUEST



Check the complete list of kits available and which can be combined with the product, consult the Immergas website, the Immergas Price List or the technical-commercial documentation (catalogues and data sheets).

INSTALLER

USER

MAINTENANCE TECHNICIAN

TECHNICAL DATA



1.23 MAIN COMPONENTS

INSTALLER

USER

MAINTENANCE TECHNICIAN

TECHNICAL DATA

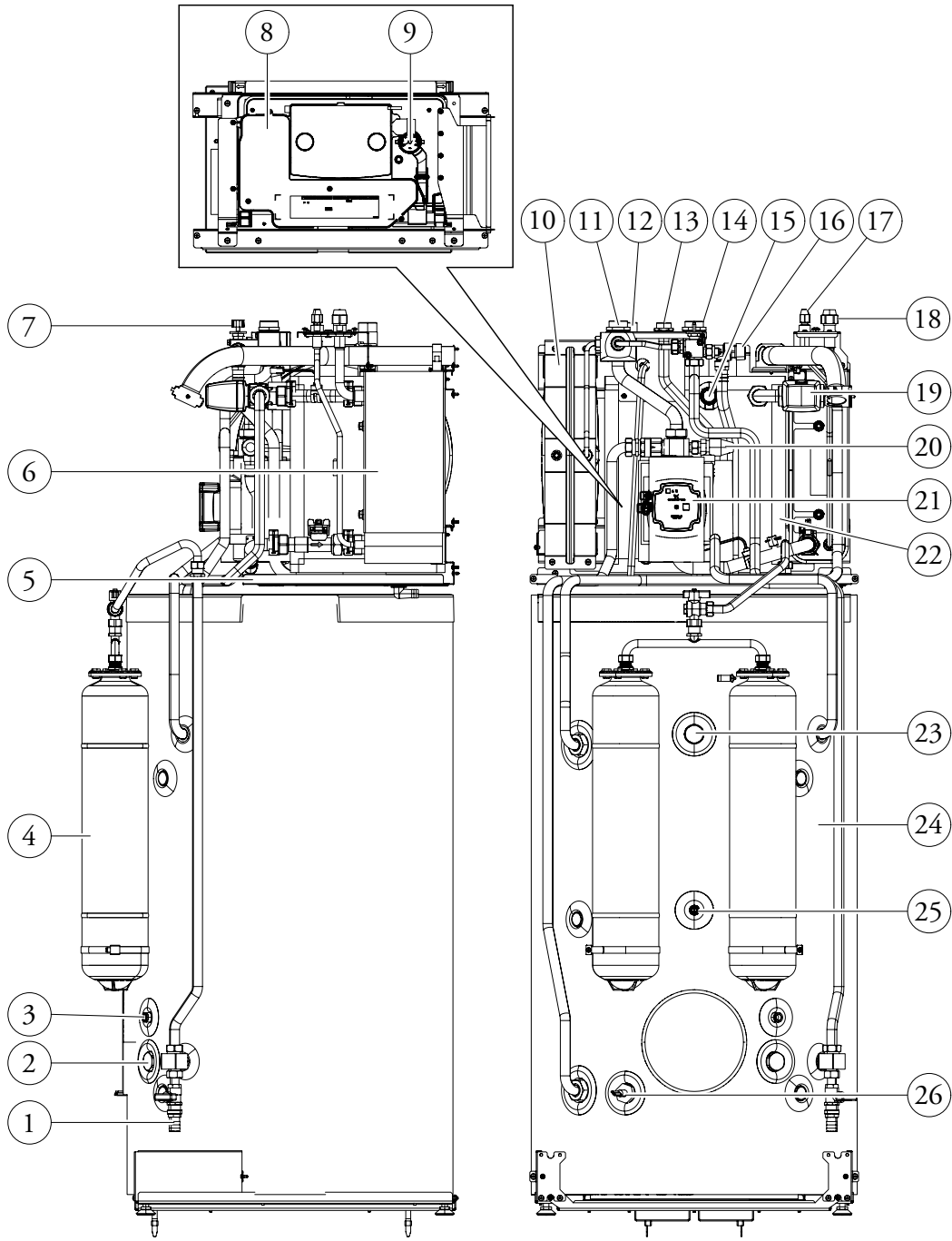

30

Key (Fig. 30):

- | | | | | | |
|---|-------------------------------------|----|--|----|--------------------------------|
| 1 | - Storage tank draining valve | 10 | - System expansion vessel | 19 | - 3-way valve (motorised) |
| 2 | - Sacrificial anode | 11 | - System return fitting | 20 | - System safety valve |
| 3 | - Solar probe | 12 | - System flow fitting | 21 | - Heat pump circulator |
| 4 | - DHW expansion vessel | 13 | - Cold water inlet fitting | 22 | - Inertial storage tank 25L |
| 5 | - Condensate collection tray | 14 | - Hot water outlet fitting | 23 | - Sacrificial anode |
| 6 | - Water/gas plate heat exchanger | 15 | - System electrical resistance | 24 | - Stainless steel storage tank |
| 7 | - Filling valve/tap | 16 | - 8 bars safety valve | 25 | - D.H.W. probe |
| 8 | - Electrical connection compartment | 17 | - Chiller line connection liquid status | 26 | - DHW electrical resistance |
| 9 | - System manometer | 18 | - Chiller line connection gaseous status | | |



2 INSTRUCTIONS FOR USE AND MAINTENANCE

2.1 GENERAL RECOMMENDATIONS



The device can be used by children at least 8 years old as well as by persons with reduced physical, sensory or mental capabilities, or lack of experience or required knowledge, provided that they are under surveillance, or after they have been instructed relating to the safe use and have understood the potential dangers.

Children must not play with the appliance.

Cleaning and maintenance destined to be performed by the user can not be carried out by unsupervised children.



If temporary shutdown of the Indoor Unit is required, proceed as follows:

- a) drain the heating system if antifreeze is not used;
- b) shut off the electrical and water supply.



Never clean the appliance or connected parts with easily flammable substances.



Never leave containers or flammable substances in the same environment as the appliance.



Do not open or tamper with the appliance.



Only use the user interface devices listed in this section of the booklet.



Do not climb on the appliance, do not use the appliance as a support base.



In the event of malfunctions, faults or incorrect operation, turn the appliance off and contact an authorised company (e.g. the Authorised Technical Assistance Centre, which has specifically trained staff and original spare parts).

Do not attempt to modify or repair the appliance alone.



The use of components involving use of electrical power requires some fundamental rules to be observed such as:

- do not touch the appliance with wet or moist parts of the body; do not touch when barefoot;
- never pull electrical cables or leave the appliance exposed to atmospheric agents (rain, sunlight, etc.);
- the appliance power cable must not be replaced by the user;
- in the event of damage to the cable, switch off the appliance and contact exclusively qualified staff for replacement;
- if the appliance is not to be used for a certain period, disconnect the main Indoor Unit external switch.





**Water at a temperature of more than 50 °C can cause serious burns.
Always check the water temperature before any use.**



The temperatures indicated by the display have a tolerance of +/- 3°C due to environmental conditions that cannot be blamed on the Indoor Unit.



**At the end of its service life, the appliance must not be disposed of like normal household waste nor abandoned in the environment, but must be removed by a professionally authorised company as required by current legislation.
Contact the manufacturer for disposal instructions.**



2.2 CLEANING AND MAINTENANCE



To preserve the system's integrity and keep the safety features, performance and reliability, which distinguish the assembly, unchanged over time, you must execute maintenance operations on a yearly basis in compliance with what is stated in the relative point at “annual check and maintenance of the appliance”, in compliance with national, regional, or local standards in force.

2.3 CONTROL PANEL

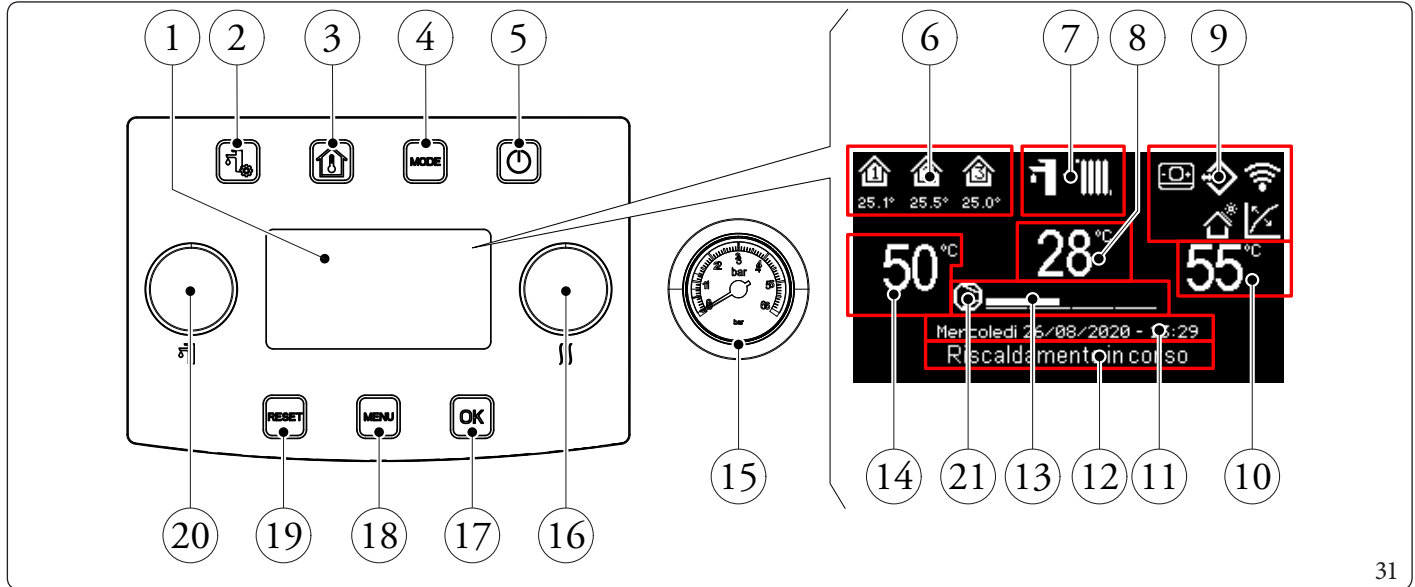

Key (Fig. 31):

- | | | | | | |
|----|---|---|----|---|---------------------------------------|
| 1 | - | Display. | 11 | - | Current date and time display. |
| 2 | - | “DHW (Domestic hot water)” menu button. | 12 | - | System status display. |
| 3 | - | “Zones” button. | 13 | - | Heat pump power scale display. |
| 4 | - | Functioning mode button. | 14 | - | DHW (Domestic hot water) set display. |
| 5 | - | ON/OFF Button. | 15 | - | Pressure gauge. |
| 6 | - | Zones area (number and information of zone in use). | 16 | - | “Heating/cooling set” knob. |
| 7 | - | Operating mode. | 17 | - | Selection confirmation/ok button. |
| 8 | - | Anomaly code/flow temperature display. | 18 | - | “Menu” Button. |
| 9 | - | System general icon display. | 19 | - | Anomalies/esc. reset button. |
| 10 | - | Central heating / C.H. set display. | 20 | - | “Set DHW (Domestic hot water)” Knob. |
| | | | 21 | - | Internal pump running |



2.4 SYSTEM USE



Before ignition, make sure the system is full of water, checking that the pressure gauge needle (Fig. 31) points to a value between 1 and 1.2 bar and make sure that the chiller circuit has been filled as described in the outdoor unit instructions booklet.

The following are displayed upon ignition:

- Type of panel;
- Panel firmware version;
- Board firmware version.

Once the device has been powered, it goes into the status prior to switch-off. Press the “MODE” button to cyclically select the desired operating mode amongst those available.

The operating mode in use is indicated by its icon at the top of the display (Fig. 32) and is unique for all zones. By pressing any button, the pushbutton panel lights up for a few seconds; in this way it is activated and ready to receive the subsequent commands. Depending on the system's configuration, the main screen displays various information regarding the system itself, amongst which:

Symbol	Description and operation
	Identification icon of zone controlled by Remote Panel (Temperature Humidity Probe or Remote Panel). During the central heating/cooling demand, the area inside the symbol is coloured, whereas in the absence of demand, the colour inside the symbol goes back to that of the display background. The values below the zone icon, respectively indicate the temperature and the humidity detected in such zone
	Identification icon of zone controlled by Room Thermostat. During the central heating/cooling demand, the area inside the symbol is coloured, whereas in the absence of demand, the colour inside the symbol goes back to that of the display background
	Dominus enabled
	Zone remote panel enabling
	Thermoregulation enabled on at least one zone
	Active holiday program
	Enabling of humidity temperature room probes or Home Automation Manager (BMS) enabled
	Active photovoltaic function
	Indoor unit pump running

Operating mode	Description	DHW	Cooling	Central heating	Protection function (antifreeze, ...)
OFF	Off	Disabled	Disabled	Disabled	Disabled
	Summer	Enabled	Disabled	Disabled	Activated
	Summer with Cooling	Enabled	Enabled	Disabled	Activated
	Winter	Enabled	Disabled	Enabled	Activated
	Stand-by	Disabled	Disabled	Disabled	Activated

Below is a description of how to use the control panel, including:

- Enter the menus;
- Moving in the menus;
- Set a menu item;
- Confirming a change;
- Exit without saving.



- **Enter the menus**

The control panel menus can be accessed by pressing the buttons (Fig. 31):

- **Moving in the menus**

Simply rotate the “Set DHW (Domestic hot water)” knob to scroll the menu items.

The indication “[...]” next to the menu item indicates the availability of a submenu.

Press the “OK” button to access this submenu.

Pressing the “RESET” button goes back to the previous menu page.

- **Set menu item**

Go to the menu item to be set following the instructions given previously.

Once the menu item to be set is reached, press “OK” or rotate the “Set cooling/central heating / C.H.” knob to highlight the value to be changed.

Change the value by turning the “Set cooling/central heating / C.H.” knob.

- **Confirming a change**

At the end of the modification, press “OK” to confirm the change and go back to the previously selected menu item.







- **Exit without saving**

If at the end of the modification you press “RESET”, you will return to the previously selected menu item without confirming the modification.





2.5 OPERATING MODE

The indoor unit can work in the following modes:

- OFF;
- STAND-BY ();
- SUMMER ();
- SUMMER WITH COOLING ( + );
- WINTER ( + .

If the indoor unit is at "OFF", press the button "" to activate it. If this is not the case, go to the next point.

Then press the "MODE" button in sequence to set the system to stand-by , summer , summer with cooling  + , winter  +  position.

- **"OFF" mode**

By pressing this button, the display will show "Off" and the system will be off. In this mode, the safety functions are not guaranteed and the remote devices are disconnected (Fig.32).



In these conditions the Indoor Unit is considered still live even if there are no functions active.

- **"Stand-by" Mode**

Press the "MODE" button in succession until the  symbol appears.

In this mode, the system is able to ensure protection functions only, such as: antifreeze function, antiblock function and any anomaly signals (Fig. 32).



In these conditions the system must still be considered powered.

- **Summer**

Press the "MODE" button in succession until the  symbol appears.

In this mode the system allows the production of domestic hot water and ensures protection (Fig. 32).

- **Summer with cooling**

Press the "MODE" button in succession until the " + " symbol appears.

In this mode the system allows the production of domestic hot water, room cooling and dehumidification and ensures protection (Fig. 32).

- **Winter**

Press the "MODE" button in succession until the  +  symbol appears.

In this mode the system allows the production of domestic hot water and room central heating / C.H. and ensures protection (Fig. 32).

List of functions

The following functions can be set on the internal unit:

- DHW (Domestic hot water);
- Central heating / C.H.;
- Cooling;
- Dehumidify.



DHW

The domestic hot water can be produced with the heat pump or with electrical resistance.

The system automatically manages the activation of the generators to heat up the domestic hot water in the storage tank.

When the set temperature is reached, the system stops the generators and turns them back on when the temperature inside the storage tank lowers by the value corresponding to parameter "DHW hysteresis".

During activation, 'DHW underway' appears on the display.

It is possible to set the domestic hot water temperature adjustment in two ways: MANUAL or AUTOMATIC.

The selection is made by entering the menu "DHW" ("DHW" button) and setting the parameter "Set Management".

Manual adjustment (Man)

Adjustment of the DHW temperature in MAN mode is done via the "DHW Set" knob (Fig. 31) or by changing the value "Manual set" within the "DHW" menu.

Confirmation can take place in two ways: by pressing the OK button or by waiting two minutes after changing the value.

Automatic adjustment (Auto)

The AUTOMATIC DHW temperature adjustment involves setting "Comfort Set" and "Economy Set" parameters in the "DHW" menu and choosing the calendar inside the menu:

Clock and programs / DHW Program

In the selected time slots, the DHW set will be automatically set to the "Comfort Set" value; outside these, the set DHW will be set to "Economy Set" value.

It is possible to temporarily modify the DHW set by setting a manual value using the "Set DHW" knob (Fig. 31).

This setting will be lost when the time slot is next changed.

DHW (Domestic hot water) Boost

Activating the "DHW (Domestic hot water) Boost" function via the menu

DHW / Boost Function = On

DHW (Domestic hot water) operation takes place with the contribution of both the heat pump and the electrical resistance, with a logic that minimises storage tank charging time.

Central heating

It is possible to set the central heating / C.H. activation parameters for each individual zone in three different ways: MANUAL, AUTOMATIC, OFF.

The selection is made by entering the "Zones"  menu and after having selected the zone of interest, access the menu

Settings / Operation mode

There are two types of requests:

- Request from room temperature in the presence of remote control

Information / Enable remote contr. = Probe / Panel

- Request from TA (room thermostat)

Enablings / Enable room thermostat = Yes

- In the first case, the system works in the following way:

Manual adjustment (Man)

The central heating / C.H. request is adjusted according to a fixed room setpoint

C.H. / Manual set

When the room temperature is lower than the manual central heating / C.H. set, the appliance is started in central heating / C.H. mode.

Automatic adjustment (Auto)

There are two room temperature setpoints:

C.H. / Comfort Set

C.H. / Economy Set



By associating a calendar with the relevant zone program, it is possible to determine the time slots for activating the central heating / C.H. comfort set. The time slots not set, correspond to the central heating / C.H. economy set.

When the detected room temperature is below the central heating / C.H. set active at that moment, the appliance is activated in central heating / C.H. mode.

Adjustment OFF

Central heating / C.H. always off.

- In the second case, the system works in the following way:

Manual adjustment (Man)

The central heating / C.H. demand is activated according to the closing of the TA contact of the relative zone.

Automatic adjustment (Auto)

The central heating / C.H. demand is activated according to the closing of the TA contact of the relative zone, during zone presence in the comfort band.

Adjustment OFF

Central heating / C.H. always off.

Cooling

It is possible to set the cooling activation parameters for each individual zone in three different ways: MANUAL, AUTOMATIC, OFF.

The selection is made by entering the "Zones"  menu and after having selected the zone of interest, access the menu

Settings / Operation mode

There are two types of requests:

- Request from room temperature in the presence of remote control

Enablings / Enable remote contr. = Probe / Panel

- Request from TA (room thermostat)

Enablings / Enable room thermostat = Yes

- In the first case, the system works in the following way:

Manual adjustment (Man)

The cooling request is adjusted according to a fixed room setpoint

Cooling / Manual set

When the room temperature is higher than the manual cooling set, the appliance is started in cooling mode.

Automatic adjustment (Auto)

There are two reference setpoints:

Cooling / Comfort Set

Cooling / Economy Set

By associating a calendar with the relevant zone program, it is possible to determine the time slots for activating the cooling comfort set. The time slots not set, correspond to the cooling economy set.

When the detected room temperature is above the cooling set active at that moment, the appliance is activated in cooling mode.

Adjustment OFF

Cooling always off.

- In the second case, the system works in the following way:

Manual adjustment (Man)

The cooling demand is activated according to the closing of the TA contact of the relative zone.

Automatic adjustment (Auto)

The cooling demand is activated according to the closing of the TA contact of the relative zone, during zone presence in the comfort band.

Adjustment OFF

Cooling always off.



Dehumidify

If the system is coupled to a humidistat (optional) or a remote zone panel (optional) or a temperature and humidity probe (optional), you can manage the room humidity in summer air conditioning mode.

- If coupled to a humidistat, set the degree of humidity on the humidistat itself (see the instruction booklet).
- If coupled to a humidity temperature sensor, set the humidity percentage in the relative user menu.
- If coupled to a zone remote panel, set the humidity percentage in the relative user menu of the control panel or directly in the menu of the panel (see instruction booklet).

The dehumidification adjustment parameters can be set by entering the "Zones"  menu and selecting the zone of interest by accessing the settings menu and finally the menu

Dehumidification / Set humidity

Dehumidification disabling

It is possible to disable dehumidification for a time slot, typically a night time slot, by setting

Dehumidification / Hourly disabling = Yes

and the start and end times of disabling.



In central heating or cooling request mode, if the temperature of the water in the system meets the request, the system can work simply by activating the circulator pump.

Clock and programs

From this menu, it is possible to set the system's date and time as well as the time slots for operation in Comfort and Economy mode.

• Date and time.

The date and time can be set by modifying the parameters in the menu

Clock and programs / Set date and time

Set date and time	
TIME	22:22
DAY	5
MONTH	1
YEAR	2020

33

• Time slots

It is possible to set 4 calendars with 4 time operating slots in system comfort mode. The system will operate in economy mode during out-of-range time of these 4 time slots.

After setting these 4 calendars it is possible to associate them to the various days of the week in the zone programs, DHW (Domestic hot water) and recirculation according to one's needs.

Set the time slots by modifying the menu

Clock and programs / Time slots

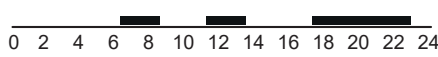
Time slots	
Calendar	: 1
	
[1] 06:15 - 08:30	[3] 17:45 - 23:00
[2] 11:30 - 13:45	[4] 24:00 - 24:00

34



- **Program for Zone 1, Zone 2 (if present), Zone 3 (if present), DHW (Domestic hot water) and recirculation.**

Time ranges (calendars from 1 to 4) are assigned to Zone 1, Zone 2 (if present), Zone 3 (if present), DHW (Domestic hot water) and Central heating / C.H. in these menus.

You can assign the calendar to a single day or to a group of days (single day, Monday - Friday, Saturday-Sunday, Monday - Saturday, Monday - Sunday).

Therefore each day may be personalised with 4 different operating programs.

For convenient selection, the bottom part displays the graphics of the relevant calendar being selected (Fig. 35).

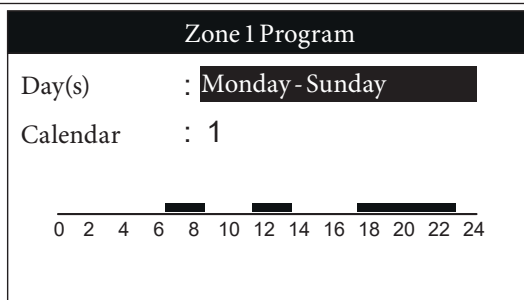

35



On the menu

Zone / Information

it is possible to identify the status of the various controls managing the central heating / C.H..

- **Holiday program.**

If required, it is possible to pause system operation for an established period.

Clock and programs / Holiday Program

Set the period in which you wish to pause system operation. During this time, the previously set calendars will not be taken into consideration.

The antifreeze function is still ensured during the holiday period.

Heat pump disabling

It is possible to disable the heat pump operation for a certain time slot, by setting

User / Disable HP = Yes

and the start and end times of disabling.

Integration Disabling

The use of the integration electrical resistances can be permanently disabled by setting

User / Disable Integration = Yes

Automatic Vent Function

In the case of new systems and, in particular, for floor systems, it is very important that de-aeration is performed correctly.

The function consists of the cyclic activation of the pumps and the 3-way valve.

The function is activated by setting

User / Enable func. Deaeration = Yes

De-aeration lasts 9 hours and it can be interrupted by setting

User / Enable func. Deaeration = No



Screed Heater Function

The Indoor Unit is equipped with a function to perform the thermal shock on new radiant panel systems, as required by the applicable standard.



Contact the manufacturer of the radiant panels for the thermal shock characteristics and its correct execution.



To be able to activate the function there must be no remote control connected, while in case of system divided into zones it must be properly connected, both hydraulically and electrically.

The active zone pumps are those with ongoing requests, made via the room thermostat input.

The standard function lasts in total 7 days - 3 days at the lowest temperature set and 4 days at the highest temperature set (Fig. 36).

Duration can be changed by changing the value of the parameters

Screed heater / Min dwell time set

Screed heater / Max dwell time set

and the temperature gradients within the same menu.

The function is activated from the indoor unit in stand-by, by accessing the menu

Screed heater / Activation

At this point, "Screed heater underway" appears on the display.

In case of failure, the function is suspended and will resume when normal operating conditions are reset from the point where it was interrupted.

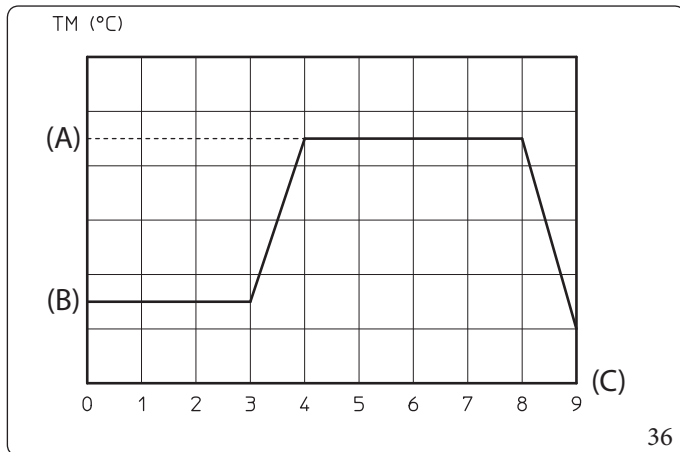

Key (Fig. 36):

(A) - Top set

(B) - Lower set

(C) - Days

Operation with external probe

It is possible to use the thermoregulation functions associated to an external probe.

The system is standard set up to use the outdoor unit external probe or an optional external probe.

With the external probe connected and the thermoregulation function active, the system flow setpoint for room central heating / C.H. or cooling is managed by the system according to the outdoor temperature measured (Par. 1.14).

You can correct the flow setpoint by choosing the offset value in the specific user menu.

It is possible to enable thermal adjustment for each individual zone. The symbol is present in case of thermoregulation of at least one zone.

Room Antifreeze Function

The room frost protection function serves to ensure the protection of system components. If the room temperature of the zone falls below the limit set in the 'Special Parameters' menu, the heat pump is switched on until the set antifreeze protection temperature increased by 1°C is reached.

To enable this function, a zone remote panel or a zone humidity temperature probe is required.



2.6 PARAMETERS AND INFORMATION MENU

Menu "DHW".

Press the "DHW (Domestic hot water)" button to access a list of variables that enable you to customise use of the DHW (Domestic hot water).

Hereunder is a list of all available menus:



The following menus refer to display board firmware rev. 2.00 and supervision board rev. 2.01.

DHW				
Menu item	Description	Range	Default	Customised value
Boost Function	Enabling of DHW (Domestic hot water) BOOST function	Off / On / Auto	Off	
Set Management	Enabling of the DHW (Domestic hot water) setpoint management in Automatic mode	Manual / Auto	Manual	
Comfort Set	Domestic hot water accumulation setpoint in Comfort phase (Automatic mode)	20 ÷ 65 °C	20 °C	
Economy Set	Domestic hot water accumulation setpoint in Economy phase (Automatic mode)	10 ÷ 35 °C	10 °C	
Manual set	Domestic hot water accumulation setpoint in Manual phase	10 ÷ 65 °C	10 °C	
Temperature	Display of the DHW (Domestic hot water) temperature	-	-	



Zones Menu.

Press the "Zones" BUTTON  to access a list of variables that enable you to customise use of the zones.

Below is the complete list of available menus, some of which are only visible after enabling the component or activating the specific associated function:

Zones	
Menu item	Description
Zone 1	Defines the operating parameters to manage zone 1.
Zone 2 (*)	Defines the operating parameters to manage the zone 2 (if present).
Zone 3 (*)	Defines the operating parameters to manage the zone 3 (if present).
General information	This display system operating data.

(*) if present.

Zones / Zone 1	
Menu item	Description
Information	This displays the system operating data.
Settings	Defines the operating parameters to manage zone 1.

Zones / Zone 1 / Information	
Menu item	Description
Room temperature	Room temperature on zone 1
Room humidity	Zone 1 room humidity
Dew temperature	Zone 1 dew temperature
Room humidity set	Room humidity setpoint set on zone 1
Set room temperature	Room setpoint set on zone 1
Flow set	Flow setpoint on zone 1
Flow temperature	Flow temperature set on zone 1
Operation status (**)	Description of the zone 1 operating mode Off = zone in OFF mode Economy = Zone in economy mode Comfort = zone in comfort mode Manual = zone in manual mode
Room Thermostat Stat. (**)	Yes = Zone TA contact closed No = TA contact open

(**) Menu entry only visible with "Service" access.



Zones/Zone 1/Settings				
Menu item	Description	Range	Default	Customised value
Operation mode	Setting of the zone 1 operating mode. Off = zone in OFF mode Auto = Zone in Automatic mode Manual = zone in manual mode	Off/Manual/ Auto	Auto	
C.H.				
Cooling				
Dehumidification				

Zones/Zone 1/Settings/C.H.				
Menu item	Description	Range	Default	Customised value
Comfort Set	Room setpoint in central heating zone 1 Comfort mode (Auto mode)	10 ÷ 35°C	20°C	
Economy Set	Room setpoint in central heating zone 1 Economy mode (Auto mode)	5 ÷ 30°C	16°C	
Manual set	Room setpoint in central heating zone 1 manual mode	5 ÷ 35°C	20°C	
Flow set	Flow setpoint set for zone 1 in central heating/ C.H.	10 – 65°C	25°C	
Flow offset	Offset temperature for central heating zone 1	-9 ÷ +9°C	0°C	

Zones/Zone 1/Settings/Cooling				
Menu item	Description	Range	Default	Customised value
Comfort Set	Room temperature in cooling zone 1 in Comfort mode (Auto mode)	10 ÷ 35°C	25°C	
Economy Set	Room temperature in cooling zone 1 in Economy mode (Auto mode)	5 ÷ 30°C	28°C	
Manual set	Room setpoint in cooling zone 1 manual mode	5 ÷ 35°C	25°C	
Flow set	Flow setpoint set for zone 1 in cooling	5 ÷ 25°C	20°C	
Flow offset	Offset temperature for cooling zone 1	-9 ÷ +9°C	0°C	

Zones/Zone 1/Settings/Dehumidification				
Menu item	Description	Range	Default	Customised value
Set humidity	Humidity setpoint for zone 1	30 ÷ 70 %	50 %	
Hourly disabling	Disabling of request to the dehumidifier, according to the daily time slot	No/Yes	No	
Hourly disable start	Time of dehumidification request disabling phase start	0-23h	22h	
Hourly disable end	Time of dehumidification request disabling phase end	0-23h	8h	
Dehum. flow set	Flow setpoint for zone 1 in dehumidification mode	5-50°C	20°C	



Zones / Zone2 (*)	
Menu item	Description
Information	This displays the system operating data.
Settings	Defines the operating parameters to manage the zone 2.

(*) if present.

Zones / Zone2 (*) / Information	
Menu item	Description
Room temperature	Room temperature on zone 2
Room humidity	Zone 2 room humidity
Dew temperature	Zone 2 dew temperature
Room humidity set	Room humidity setpoint set on zone 2
Set room temperature	Room setpoint set on zone 2
Flow set	Flow setpoint on zone 2
Flow temperature	Flow temperature set on zone 2
Operation status (**)	Description of the zone 2 operating mode Off = zone in OFF mode Economy = Zone in economy mode Comfort = zone in comfort mode Manual = zone in manual mode
Room Thermostat Stat. (**)	Yes = Zone TA contact closed No = TA contact open

(*) if present.

(**) Menu entry only visible with "Service" access.

Zones / Zone2 (*) / Settings				
Menu item	Description	Range	Default	Customised value
Operation mode	Setting of the zone 2 operating mode. Off = zone in OFF mode Auto = Zone in Automatic mode Manual = zone in manual mode	Off / Manual / Auto	Auto	
C.H.				
Cooling				
Dehumidification				

(*) if present.

INSTALLER

USER

MAINTENANCE TECHNICIAN

TECHNICAL DATA



Zones / Zone 2 (*) / Settings / C.H.				
Menu item	Description	Range	Default	Customised value
Comfort Set	Room setpoint in central heating zone 2 Comfort mode (Auto mode)	10 ÷ 35°C	20°C	
Economy Set	Room setpoint in central heating zone 2 Economy mode (Auto mode)	5 ÷ 30°C	16°C	
Manual set	Room setpoint in central heating zone 2 manual mode	5 ÷ 35°C	20°C	
Flow set	Flow setpoint set for zone 2 in central heating / C.H.	10 – 65°C	25°C	
Flow offset	Offset temperature for central heating zone 2	-9 ÷ +9°C	0°C	

(*) if present.

Zones / Zone 2 (*) / Settings / Cooling				
Menu item	Description	Range	Default	Customised value
Comfort Set	Room temperature in cooling zone 2 in Comfort mode (Auto mode)	10 ÷ 35°C	25°C	
Economy Set	Room temperature in cooling zone 2 in Economy mode (Auto mode)	5 ÷ 30°C	28°C	
Manual set	Room setpoint in cooling zone 2 manual mode	5 ÷ 35°C	25°C	
Flow set	Flow setpoint set for zone 2 in cooling	5 ÷ 25°C	20°C	
Flow offset	Offset temperature for cooling zone 2	-9 ÷ +9°C	0°C	

(*) if present.

Zones / Zone 2 (*) / Settings / Dehumidification				
Menu item	Description	Range	Default	Customised value
Set humidity	Humidity setpoint for zone 2	30 ÷ 70%	50%	
Hourly disabling	Disabling of request to the dehumidifier, according to the daily time slot	No / Yes	No	
Hourly disable start	Time of dehumidification request disabling phase start	0-23h	22h	
Hourly disable end	Time of dehumidification request disabling phase end	0-23h	8h	
Dehum. flow set	Flow setpoint for zone 2 in dehumidification mode	5-50°C	20°C	

(*) if present.



Zones / Zone 3 (*)	
Menu item	Description
Information	This displays the system operating data.
Settings	Defines the operating parameters to manage the zone 3.

(*) if present.

Zones / Zone 3 (*) / Information	
Menu item	Description
Room temperature	Room temperature on zone 3
Room humidity	Zone 3 room humidity
Dew temperature	Zone 3 dew temperature
Room humidity set	Room humidity setpoint set on zone 3
Set room temperature	Room setpoint set on zone 3
Flow set	Flow setpoint on zone 3
Flow temperature	Flow temperature set on zone 3
Operation status (**)	Description of the zone 3 operating mode Off = zone in OFF mode Economy = Zone in economy mode Comfort = zone in comfort mode Manual = zone in manual mode
Room Thermostat Stat. (**)	Yes = Zone TA contact closed No = TA contact open

(*) if present.

(**) Menu entry only visible with "Service" access.

Zones / Zone 3 (*) / Settings				
Menu item	Description	Range	Default	Customised value
Operation mode	Setting of the zone 3 operating mode. Off = zone in OFF mode Auto = Zone in Automatic mode Manual = zone in manual mode	Off / Manual / Auto	Auto	
C.H.				
Cooling				
Dehumidification				

(*) if present.

INSTALLER

USER

MAINTENANCE TECHNICIAN

TECHNICAL DATA



Zones / Zone 3 (*) / Settings / C.H.				
Menu item	Description	Range	Default	Customised value
Comfort Set	Room setpoint in central heating zone 3 Comfort mode (Auto mode)	10 ÷ 35°C	20°C	
Economy Set	Room setpoint in central heating zone 3 Economy mode (Auto mode)	5 ÷ 30°C	16°C	
Manual set	Room setpoint in central heating zone 3 manual mode	5 ÷ 35°C	20°C	
Flow set	Flow setpoint set for zone 3 in central heating / C.H.	10 – 65°C	25°C	
Flow offset	Offset temperature for central heating zone 3	-9 ÷ +9°C	0°C	

(*) if present.

Zones / Zone 3 (*) / Settings / Cooling				
Menu item	Description	Range	Default	Customised value
Comfort Set	Room temperature in cooling zone 3 in Comfort mode (Auto mode)	10 ÷ 35°C	25°C	
Economy Set	Room temperature in cooling zone 3 in Economy mode (Auto mode)	5 ÷ 30°C	28°C	
Manual set	Room setpoint in cooling zone 3 manual mode	5 ÷ 35°C	25°C	
Flow set	Flow setpoint set for zone 3 in cooling	5 ÷ 25°C	20°C	
Flow offset	Offset temperature for cooling zone 3	-9 ÷ +9°C	0°C	

(*) if present.

Zones / Zone 3 (*) / Settings / Dehumidification				
Menu item	Description	Range	Default	Customised value
Set humidity	Humidity setpoint for zone 3	30 ÷ 70%	50%	
Hourly disabling	Disabling of request to the dehumidifier, according to the daily time slot	No / Yes	No	
Hourly disable start	Time of dehumidification request disabling phase start	0-23h	22h	
Hourly disable end	Time of dehumidification request disabling phase end	0-23h	8h	
Dehum. flow set	Flow setpoint for zone 3 in dehumidification mode	5-50°C	20°C	

(*) if present.



Zones/General information

Menu item	Description	Range	Default	Customised value
Outside temperature	External temperature detected by the external probe	-	-	
System flow set	Flow temperature set on the system	-	-	
Zone 1 flow set	Flow temperature set on zone 1	-	-	
Zone 1 request	Request present on zone 1 No = no request CH = Central heating request Cool. = Cooling request Dehumid. = Dehumidification request in neutral air R. Air = Dehumidification request in cooled air R + D = Cooling and dehumidification requests in neutral air R + A = Cooling and dehumidification requests in cool air	No CH Cool. Dehumid. R. Air R + D R + A	-	
Zone 2 flow set (*)	Flow temperature set on zone 2 (if present)	-	-	
Zone 2 request (*)	Request present on zone 2 No = no request CH = Central heating request Cool. = Cooling request Dehumid. = Dehumidification request in neutral air R. Air = Dehumidification request in cooled air R + D = Cooling and dehumidification requests in neutral air R + A = Cooling and dehumidification requests in cool air	No CH Cool. Dehumid. R. Air R + D R + A	-	
Zone 3 flow set (*)	Flow temperature set on zone 3 (if present)	-	-	
Zone 3 request (*)	Request present on zone 3 No = no request CH = Central heating request Cool. = Cooling request Dehumid. = Dehumidification request in neutral air R. Air = Dehumidification request in cooled air R + D = Cooling and dehumidification requests in neutral air R + A = Cooling and dehumidification requests in cool air	No CH Cool. Dehumid. R. Air R + D R + A	-	

(*) if present.

INSTALLER

USER

MAINTENANCE TECHNICIAN

TECHNICAL DATA



Main Menu

Press the "MENU" button to access a list of variables that enable you to customise use of the system.
Hereunder is a list of all available menus:

Menu	
Menu item	Description
Clock and programs	Defines the date/time and time operating slots
User	Defines the system parameters that can be modified by the user
Information	Display system operating data
Gestione anomalie	Displays the list of the last 10 anomalies and resets the fault history
General settings	Allows selecting the panel operating language, the display operating mode and to access the password-protected menus dedicated to a qualified technician.

Menu/ Clock and programs				
Menu item	Description	Range	Default	Customised value
Set date and time	Defines the system clock and calendar	-	-	
Automatic summer time	Defines whether to activate the summer time changeover	Yes/No	Yes	
Time slots	Set the 4 time slots of each calendar.	00.00 - 24.00h	-	
Zone 1 Program	Zone 1 time scheduling	-	-	
	Zone 1: Monday	CAL1,CAL2, CAL3,CAL4	CAL1	
	Zone 1: Tuesday	CAL1,CAL2, CAL3,CAL4	CAL1	
	Zone 1: Wednesday	CAL1,CAL2, CAL3,CAL4	CAL1	
	Zone 1: Thursday	CAL1,CAL2, CAL3,CAL4	CAL1	
	Zone 1: Friday	CAL1,CAL2, CAL3,CAL4	CAL1	
	Zone 1: Saturday	CAL1,CAL2, CAL3,CAL4	CAL1	
	Zone 1: Sunday	CAL1,CAL2, CAL3,CAL4	CAL1	



Menu / Clock and programs

Menu item	Description	Range	Default	Customised value
Zone 2 Program	Zone 2 time scheduling (if present)	-	-	
	Zone 2: Monday	CAL1, CAL2, CAL3, CAL4	CAL1	
	Zone 2: Tuesday	CAL1, CAL2, CAL3, CAL4	CAL1	
	Zone 2: Wednesday	CAL1, CAL2, CAL3, CAL4	CAL1	
	Zone 2: Thursday	CAL1, CAL2, CAL3, CAL4	CAL1	
	Zone 2: Friday	CAL1, CAL2, CAL3, CAL4	CAL1	
	Zone 2: Saturday	CAL1, CAL2, CAL3, CAL4	CAL1	
	Zone 2: Sunday	CAL1, CAL2, CAL3, CAL4	CAL1	
Zone 3 Program	Zone 3 time scheduling (if present)	-	-	
	Zone 3: Monday	CAL1, CAL2, CAL3, CAL4	CAL1	
	Zone 3: Tuesday	CAL1, CAL2, CAL3, CAL4	CAL1	
	Zone 3: Wednesday	CAL1, CAL2, CAL3, CAL4	CAL1	
	Zone 3: Thursday	CAL1, CAL2, CAL3, CAL4	CAL1	
	Zone 3: Friday	CAL1, CAL2, CAL3, CAL4	CAL1	
	Zone 3: Saturday	CAL1, CAL2, CAL3, CAL4	CAL1	
	Zone 3: Sunday	CAL1, CAL2, CAL3, CAL4	CAL1	

INSTALLER

USER

MAINTENANCE TECHNICIAN

TECHNICAL DATA



Menu/ Clock and programs				
Menu item	Description	Range	Default	Customised value
DHW Program	DHW operation time programming	-	-	
	Domestic Hot Water: Monday	CAL1,CAL2, CAL3,CAL4	CAL1	
	Domestic Hot Water: Tuesday	CAL1,CAL2, CAL3,CAL4	CAL1	
	Domestic Hot Water: Wednesday	CAL1,CAL2, CAL3,CAL4	CAL1	
	Domestic Hot Water: Thursday	CAL1,CAL2, CAL3,CAL4	CAL1	
	Domestic Hot Water: Friday	CAL1,CAL2, CAL3,CAL4	CAL1	
	Domestic Hot Water: Saturday	CAL1,CAL2, CAL3,CAL4	CAL1	
	Domestic Hot Water: Sunday	CAL1,CAL2, CAL3,CAL4	CAL1	
Recirculation Program	Recirculation operation time programming	-	-	
	Recirculation: Monday	CAL1,CAL2, CAL3,CAL4	CAL1	
	Recirculation: Tuesday	CAL1,CAL2, CAL3,CAL4	CAL1	
	Recirculation: Wednesday	CAL1,CAL2, CAL3,CAL4	CAL1	
	Recirculation: Thursday	CAL1,CAL2, CAL3,CAL4	CAL1	
	Recirculation: Friday	CAL1,CAL2, CAL3,CAL4	CAL1	
	Recirculation: Saturday	CAL1,CAL2, CAL3,CAL4	CAL1	
	Recirculation: Sunday	CAL1,CAL2, CAL3,CAL4	CAL1	
Holiday Program	Defines the period during which the system disables both hot water heating and room central heating and/or cooling functions. At the end of the set days, the previously active functions will be reset.	Off / 1 day - 30 days	Off	

Menu/ User				
Menu item	Description	Range	Default	Customised value
Disable HP	It allows you to disable the heat pump according to the set time slot or via the outdoor contact.	Yes / No	No	
Start hourly HP disab.	Allows to set when disabling starts.	0-23h	0h	
End hourly HP disab.	Allows to set when disabling ends.	0-23h	0h	
Disable Integration	Allows the integration device to be permanently disabled.	Yes / No	No	
Enable func. Deaeration	Enables the de-aeration function.	Yes / No	No	
Screed heater		-	-	



Menu / User / Screed heater				
Menu item	Description	Range	Default	Customised value
Min dwell time set	Defines the time spent at minimum operating temperature during the active function.	1 - 7 days	3 days	
Rise gradient	Defines the ascent gradient of the temperature	3 ÷ 30 °C/g	30 °C/g	
Max dwell time set	Defines the time spent at maximum operating temperature during the active function.	1 - 14 days	4 days	
Fall gradient	Defines the descent gradient of the temperature	3 ÷ 30 °C/g	30 °C/g	
Minimum flow set	Defines the minimum delivery temperature of the screed heater function	20 ÷ 45 °C	25 °C	
Maximum flow set	Defines the maximum delivery temperature of the screed heater function	25 ÷ 55 °C	45 °C	
Activation	Activation of the screed heater function	Yes / No	No	

Menu / Information	
Menu item	Description
Heat pump	Defines the heat pump operating parameters.
Board revisions	This displays the system board revisions.
Meters	This displays the operating data.

Menu / Information / Heat pump	
Menu item	Description
Flow temperature	Heat pump flow temperature
Return temperature	Heat pump return temperature
Compress.outlet temp.	Outdoor unit compressor temperature
Compress. drain temp.	Outdoor unit compressor discharge temperature
Compress.int.temp.	Not present
Expan.valve pos.	Outdoor unit expansion valve position
Heat exch.cool.temp.	Coolant temperature inside the plate heat exchanger
Coil temperature	Outdoor unit coil temperature
Outdoor HP temp.	External temperature
HP frequency	Heat pump frequency
HP request mode	Status of the request to heat pump
HP Status	Heat pump status
System resistance	System resistance active control
DHW resistance 1	Standard DHW (Domestic hot water) resistance active control
System state	Technical parameter (only for Immergas Assistance)
Integration state	Technical parameter (only for Immergas Assistance)
Output status	Technical parameter (only for Immergas Assistance)
Disable HP	Heat pump activation/deactivation status
Inverter current	Outdoor unit inverter current
Fan speed (H)	Outdoor unit high fan speed
Fan speed (L)	Outdoor unit low fan speed
HP Setpoint	Request setpoint to heat pump

INSTALLER

USER

MAINTENANCE TECHNICIAN

TECHNICAL DATA



Menu / Information / Heat pump	
Menu item	Description
Pump speed	Heat pump circulator speed
System flow temp.	System temperature
Heat. set correc.	Current correction of the flow setpoint
System flow rate	Heat pump circuit flow rate
Photovoltaic	Operating status combined with a photovoltaic system
Power reduction	Not used
Hot/Cold three-way	Summer/Winter Three-way Position
Recirculation pump	Active recirculation pump
Interface board type	Communication board type
Screed heater end days	Days left until the end of the screed heater
Recirculation Temp.	DHW recirculation probe temperature
Information 1	Heat pump configuration code
Information 2	Flow temperature calculated after electrical resistance (multiplied by 10).
Information 3	Not used
Information 4	Not used
Information 5	Parameter for internal use

Menu / Information / Board revisions	
Menu item	Description
Display board rev. SW	Remote panel software revision
Display board rev. HW	Remote panel hardware revision
Supervis. board SW	Supervision board software revision
Supervis. board BIOS	Supervision board hardware revision
EU main board rev. no.	Outdoor unit main board firmware revision
EU main board rev. date	Outdoor unit main board firmware date
EU inverter rev. no.	Outdoor unit inverter board firmware revision
EU inverter rev. date	Outdoor unit inverter board firmware date
UE eeprom rev. no.	Outdoor unit EEPROM firmware revision
UE eeprom rev. data	Outdoor unit EEPROM firmware date
EU interface rev. no.	Communication board firmware revision
EU interface rev. date	Communication board firmware data
Expans.board rev. (H)	Revision of the expansion board (top part)
Expans.board rev. (L)	Revision of the expansion board (bottom part)

Menu / Information / Meters	
Menu item	Description
HP running hours	Number of hours of operation of the compressor
Resist. run hours Heating.	Hours of operating of the electrical resistance
Resist. run hours DHW1	Hours of operation of the standard DHW (Domestic hot water) resistance
Resist. run hours DHW2	Hours of operation of the optional DHW (Domestic hot water) resistance



Menu/ **Gestione anomalie**

Menu item	Description
Reset Log	Resets the list of anomalies
Anomalies log	

Menu/ **Gestione anomalie/ Anomalies log**

Menu item	Description
History index	
Anomaly code	This displays the selected anomaly code
Technical anomaly	

Menu/ **General settings**

Menu item	Description	Range	Default	Customised value
Language	Defines the remote panel operation language	ITA - BUL - CZE - FRA - NLD - GER - ENG - GRE - LIT - POL - POR - RUM - RUS - SLO - SLV - SPA - HUN - UKR	ITA	
Display	It allows for various display adjustments.			
Access level	Allows the entry of an access code to access the parameter customisation menus according to ones needs (dedicated to a qualified technician)			

Menu/ **General settings/ Display**

Menu item	Description	Range	Default	Customised value
Contrast	Allows to adjust the display contrast	Min / 2 ÷ 9 / Max	5	
Display lighting	Allows to set the display operation mode	Off / Min / Auto / Max	Auto	



The parameters referring to zone 2 can only be displayed if there is a zone 2 on the system and it is configured correctly.



The parameters referring to zone 3 can only be displayed if there is a zone 3 on the system and it is configured correctly.



2.7 FAULT AND ANOMALY SIGNALS

The indoor unit indicates a possible anomaly through a code flanked by the symbol of a key "  " in the centre of the display and the message "indoor unit anomaly" at the bottom of the display itself (Fig. 31).

If a fault is displayed, note down the code displayed in the centre of the display in addition to the phrase "indoor unit fault" or "outdoor unit fault" and report it to the technician authorised to carry out repairs and maintenance, if necessary.

Some of these alarms are associated with a temporary event, in which case you can attempt to reset the system and the alarm by pressing the RESET button on the display.

Error Code	Anomaly signalled	Cause	Appliance status/ Solution
5	Delivery probe fault	The board detects an anomaly on the flow NTC probe.	The system does not start (1).
8	Incorrect operation/ fault reset	Number of allowed resets already performed.	The anomaly can be reset 5 consecutive times, after which the function is inhibited for at least one hour and it is possible to try once every hour, for a maximum of 5 attempts. By switching the appliance on and off again, the 5 attempts are re-acquired
12	Storage tank probe anomaly	The board detects an anomaly on the storage tank probe	The hydronic module is unable to produce domestic hot water (1).
15	Configuration error	If the board detects an anomaly or incongruity on the electric wiring, the appliance will not start	If normal conditions are restored, the heat appliance restarts without having to be reset (1).
23	Return probe anomaly	The board detects an anomaly on the return NTC probe	The system does not start (1).
24	Push button control panel anomaly	The board detects an anomaly on the pushbutton panel.	If normal conditions are restored, the system restarts without having to be reset (1).
26	Flowmeter anomaly	The board detects an anomaly on the flowmeter. Booster pump, if any, always working.	The system does not start (1). Make sure the booster pump (optional) only activates when requested.
27	Circulation insufficient	This happens when the hydronic module overheats due to poor water circulation in the primary circuit. The causes can be: - pdc pump blocked; free the pump; - damaged flowmeter.	Check system circulation and flowmeter. Press the Reset button (1).

(1) If the shutdown or fault persists, contact an authorised company (e.g. Authorised After-Sales Technical Assistance Centre).

Error Code	Anomaly signalled	Cause	Appliance status / Solution
32	Zone 2 Low Temperature probe anomaly	If the board detects an anomaly on the zone 2 low temperature probe, the system cannot work in the affected area.	(1)
33	Zone 3 low temperature probe anomaly	If the board detects an anomaly on the zone 3 low temperature probe; the system cannot work in the affected area.	(1)
34	Low-temperature Zone 2 safety thermostat intervention	During normal operation, if an anomaly causes excessive overheating of the flow temperature in the low temperature zone 2, the unit indicates the malfunction.	The unit does not meet the zone central heating requirement. (1)
35	Low-temperature zone 3 safety thermostat intervention	During normal operation, if an anomaly causes excessive overheating of the flow temperature in the low temperature zone 3, the unit indicates the malfunction.	The unit does not meet the zone central heating requirement. (1)
37	Low power supply voltage value	This occurs when the power supply voltage is lower than the allowed limits for correct system operation.	If normal conditions are restored, the system restarts without having to be reset (1)
50	External probe anomaly	In the event the external probe is not connected or is faulty, the anomaly is indicated.	Check the external probe connection. The system continues to operate with the external probe integrated in the external unit (1). In case of replacement of the external probe, repeat the installation operations.
55	Zone 1 temperature probe anomaly	The zone 1 flow probe has an out-of-range resistive value	(1)
104	Expansion off-line alarm	The expansion device is offline	(1)
120	Alarm set high for zone 1 dehumidification	The cooling flow set calculated for dehumidification is higher than the limit set in zone 1	The calculated flow set is higher than the limit allowed by the dehumidifier. Cool the room and wait for the dew temperature to go back within acceptable values (1).
121	Zone 1 offline device alarm	The device connected to zone 1 is offline	(1)
122	Zone 2 offline device alarm	The device connected to zone 2 is offline	(1)
(1) If the shutdown or fault persists, contact an authorised company (e.g. Authorised After-Sales Technical Assistance Centre).			

INSTALLER

USER

MAINTENANCE TECHNICIAN

TECHNICAL DATA



Error Code	Anomaly signalled	Cause	Appliance status / Solution
123	Zone 3 offline device alarm	The device connected to zone 3 is offline.	(1)
125	Zone 1 room temperature probe error	The zone 1 room probe has an out of range resistive value	(1)
126	Zone 2 room temperature probe error	The zone 2 room probe has an out of range resistive value	(1)
127	Zone 3 room temperature probe error	The zone 3 room probe has an out of range resistive value.	(1)
129	Zone 1 humidity probe error	Anomaly on the zone 1 humidity probe.	In addition to the humidity, the dew point is not calculated for the zone either (1). Zone humidity cannot be checked.
130	Zone 2 humidity probe error	Anomaly on the zone 2 humidity probe.	In addition to the humidity, the dew point is not calculated for the zone either (1). Zone humidity cannot be checked.
131	Zone 3 humidity probe error	Anomaly on the zone 3 humidity probe.	In addition to the humidity, the dew point is not calculated for the zone either (1). Zone humidity cannot be checked.
132	Alarm set high for zone 2 dehumidification	The cooling flow set calculated for dehumidification is higher than the limit set in zone 2	The calculated flow set exceeds the limit permitted by the dehumidifier. Cool the room and wait for the dew temperature to go back within acceptable values (1).
133	Zone 1 dehumidifier fault alarm	Anomaly coming from the dehumidifier (optional) on zone 1	The system does not dehumidify in the relative zone (1)
134	Zone 2 dehumidifier fault alarm	Anomaly coming from the dehumidifier (optional) in zone 2	The system does not dehumidify in the relative zone (1)
(1) If the shutdown or fault persists, contact an authorised company (e.g. Authorised After-Sales Technical Assistance Centre).			



Error Code	Anomaly signalled	Cause	Appliance status / Solution
135	Zone 3 dehumidifier fault alarm	Anomaly coming from the dehumidifier (optional) on zone 3	The system does not dehumidify in the relative zone (1)
136	High set alarm for dehumidification-zone 3	The cooling flow set calculated for dehumidification exceeds the limit set in zone 3	The calculated flow set is higher than the limit allowed by the dehumidifier. Cool the room and wait for the dew temperature to go back within acceptable values (1).
137	Reset system alarm – Restart the system	When the default parameters are restored, the system needs to be restarted.	Turn the system off and on.
139	De-aeration in progress	Deaeration function in progress	No demand can be made until the end of the function in progress (1)
142	Errore Dominus offline	Communication with Dominus is offline	(1)
143	Recirculation probe alarm	The board detects an anomaly on the D.H.W. recirculation probe	The system does not recirculate DHW (1)
177	DHW maximum time alarm	Domestic hot water production is not met within the pre-established time	The system continues to operate with non-optimal performance (1)
178	Block: anti-legionella cycle not successful	The anti-Legionella cycle is run without success within the pre-established time	Press the Reset button (1)
179	Liquid phase probe alarm	The board detects an anomaly on the liquid phase NTC probe.	The system does not start (1).
183	Outdoor unit in test mode	A signal notifies that the outdoor unit is in test mode.	During this time, room air conditioning and domestic hot water production requirements cannot be met
188	Request out of operating range	A request is made with the outdoor temperature exceeding the operating limits (Parag. 1.18)	The system does not start (1). Wait for the outdoor unit to be restored within operating limits.

(1) If the shutdown or fault persists, contact an authorised company (e.g. Authorised After-Sales Technical Assistance Centre).

INSTALLER

USER

MAINTENANCE TECHNICIAN

TECHNICAL DATA



Error Code	Anomaly signalled	Cause	Appliance status / Solution
189	Time out alarm with communication board	If communication between the printed circuit boards is lost, an anomaly is signalled.	The system does not start (1). Check communication between the P.C.B. and the interface board.
195	Alarm low liquid phase probe temperature	Too low temperature is detected in the liquid phase	Check that the cooling circuit is working properly (1).
196	High flow temp. block	An excessively high temperature is detected on the heat pump flow circuit	Check the hydraulic circuit (1).
197	Communication board configuration error	An incorrect communication board configuration has been detected	The system does not start (1).

(1) If the shutdown or fault persists, contact an authorised company (e.g. Authorised After-Sales Technical Assistance Centre).



List of outdoor unit anomalies

If the outdoor unit is faulty, the error code is displayed in the middle of the control panel (Fig. 31), with a key symbol next to it "  ". In addition, the message "Outdoor unit anomaly" is displayed at the bottom of the display (Fig. 31).

If a fault is displayed, note down the code displayed in the centre of the display in addition to the phrase "indoor unit fault" or "outdoor unit fault" and report it to the technician authorised to carry out repairs and maintenance, if necessary. Alarms from the outdoor unit cannot be reset using the RESET button on the display. In this case you must first disconnect power to the outdoor unit, wait a few minutes, restore it and press the RESET button on the display.

Error Code	Anomaly signalled	Hydronic module status / Solution
101	Outdoor unit communication error	Check the communication cable to the outdoor unit. Check that the interface board works properly. (1)
109	Communication error due to incorrect address of interface board	Check the address on the interface board. (1)
111	MODBUS communication error	Check communication between the management board and interface boards. (1)
162	EEPROM error	Replace the main board of the outdoor unit (1)
177	Emergency error	(1)
198	Error of thermal fuse terminal board (open)	(1)
201	Communication error (failed coupling) between interface board and outdoor unit	Check the communication cable to the outdoor unit. Check that the interface board and main board of the outdoor unit work properly (1)
202	Communication error (failed coupling) between indoor unit and interface board	Check the communication cable to the outdoor unit. Check that the interface board and main board of the outdoor unit work properly (1)
203	Communication error between Inverter and main board of the outdoor unit	Check wiring of communication between the two boards. Replace the main board. Replace the inverter board (1)

(1) If the shutdown or fault persists, contact an authorised company (e.g. Authorised After-Sales Technical Assistance Centre).



Error Code	Anomaly signalled	Hydronic module status/ Solution
221	Outdoor unit air temperature sensor error	Check the position of the sensor. Check the relative wiring Replace the sensor (1)
231	Condenser temperature sensor error	Check the position of the sensor. Check the relative wiring Replace the sensor (1)
251	Discharge temperature sensor error	Check the position of the sensor. Check the relative wiring Replace the sensor
320	Compressor sensor error (overload protection sensor)	Check the position of the sensor. Check the relative wiring Replace the sensor (1)
403	Freezing detection (during cooling operation)	Check the chiller cycle. Check the temperatures of the plate heat exchanger (1)
404	Protection of outdoor unit when in overload (during safety start-up, normal operating status)	Check the chiller cycle. Check the compressor connections. Check the resistances between the different phases of the compressor (1)
407	Compressor not working due to high pressure	Check the chiller cycle (1)
416	The compressor discharge is overheated	(1)
419	Outdoor unit EEV operation error	(1)
425	Not used on this model	(1)
440	Central heating blocked (outdoor temperature beyond 35°C)	(1)
441	Cooling blocked (outdoor temperature below 9°C)	(1)
458	Error of outdoor unit fan no.1	1
(1) If the shutdown or fault persists, contact an authorised company (e.g. Authorised After-Sales Technical Assistance Centre).		

Error Code	Anomaly signalled	Hydronic module status/ Solution
461	Compressor start-up error (Inverter)	Check the chiller cycle. Check the compressor connections. Check the resistances between the different phases of the compressor (1)
462	Inverter total current overload error	Check the inlet current. Check the refrigerant charge. Check normal operation of the fan. (1)
463	Compressor overheated sensor	Check the compressor sensor. (1)
464	Inverter IPM current overload error	Check the compressor connections and its normal operation. Check the refrigerant charge. Check whether there are obstacles around the outdoor unit. Check whether the service valve is open. Check whether the installation pipes are mounted properly. (1)
465	Compressor overload error	Check the compressor connections and its normal operation. Check the resistances between the different phases of the compressor. (1)
466	Low voltage error of DC circuit	Check the input voltage. Check the power connections. (1)
467	Compressor rotation error	Check the compressor connections. Check the resistances between the different phases of the compressor. (1)
468	Current sensor error (inverter)	Check the main board. (1)
469	Voltage sensor error of DC circuit (inverter)	Check the power connector of the inverter board. Check the connectors RY21 and R200 of the inverter board. (1)
470	EEPROM reading/writing error of outdoor unit	Check the main board. (1)
(1) If the shutdown or fault persists, contact an authorised company (e.g. Authorised After-Sales Technical Assistance Centre).		

INSTALLER

USER

MAINTENANCE TECHNICIAN

TECHNICAL DATA



Error Code	Anomaly signalled	Hydronic module status/ Solution
471	EEPROM reading/writing error of outdoor unit	Check the main board. (1)
474	Inverter temperature sensor error	Replace inverter board (1)
475	Error of outdoor unit fan no.2 (where present)	Check the wiring. Check that the fan is powered. Check the fuses in the main electrical panel. (1)
484	PFC overload	Check inductances. Replace inverter board. (1)
485	Incoming current sensor error	Replace inverter board. (1)
500	IPM overheated	Check temperature of inverter board. Switch the machine off. Wait for the inverter to cool down. Switch the machine back on. (1)
554	Coolant gas leak error	Check that the coolant is charged Check the liquid sensor of the indoor unit Check whether the service valve is open Check whether the installation pipes are mounted properly. (1)
590	Inverter board error	Check normal operation of the main board. Replace the main board (1)
601	Not present	(1)
604	Not present	(1)
653	Not present	(1)
654	Not present	(1)
899	Not present	(1)
900	Not present	(1)
901	Not used	Indoor unit error Check indoor unit (1)

(1) If the shutdown or fault persists, contact an authorised company (e.g. Authorised After-Sales Technical Assistance Centre).



Error Code	Anomaly signalled	Hydronic module status/Solution
902	Not used	Indoor unit error Check indoor unit (1)
903	Not used	Indoor unit error Check indoor unit (1)
904	Not used	Indoor unit error Check indoor unit (1)
906	Not used	Indoor unit error Check indoor unit (1)
911	Not used	Indoor unit error Check indoor unit (1)
912	Not used	Indoor unit error Check indoor unit (1)
916	Not used	Indoor unit error Check indoor unit (1)
919	Not used	Indoor unit error Check indoor unit (1)

(1) If the shutdown or fault persists, contact an authorised company (e.g. Authorised After-Sales Technical Assistance Centre).

INSTALLER

USER

MAINTENANCE TECHNICIAN

TECHNICAL DATA



2.8 RESTORE CENTRAL HEATING SYSTEM PRESSURE

1. Periodically check the system water pressure (the Indoor Unit's pressure gauge hand must indicate a value between 1 and 1.2 bar).
2. If the pressure falls below 1 bar (with the system cold) restore normal pressure via the valve located at the top of the appliance (Fig. 37).
3. Close the valve after the operation.
4. If the pressure reaches values around 3 bar, there is a risk of tripping the safety valve (in this case, remove water from a radiator air vent valve until a pressure of 1 bar is achieved, or ask for assistance from professionally qualified personnel).
5. In the event of frequent pressure drops, contact qualified staff for assistance to eliminate the possible system leakage.

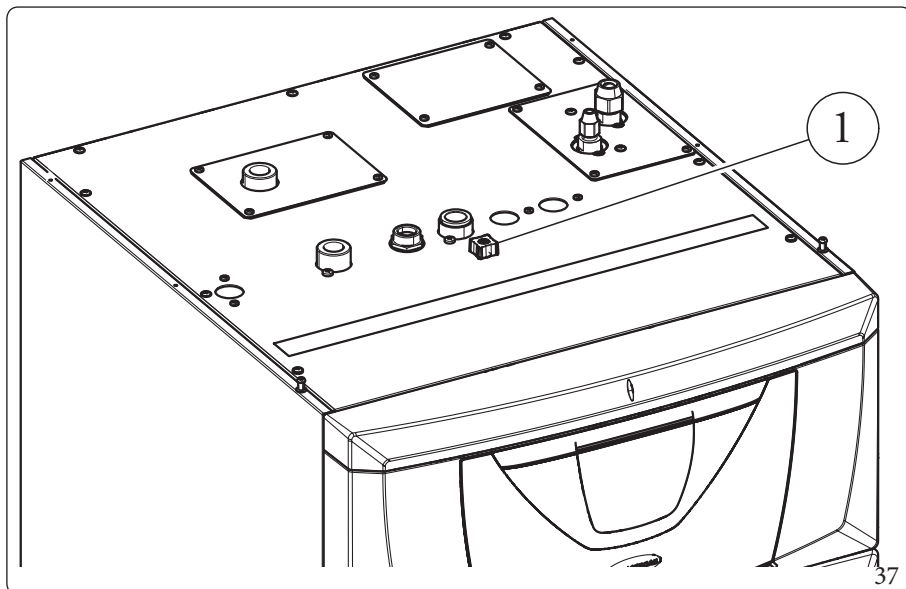

Key (Fig. 37):

1 - System filling valve

2.9 DRAINING THE SYSTEM

1. Ensure that the filling valve is closed.
2. Open the draining valve (1, Fig. 30).
3. Open all vent valves.
4. At the end, close the draining valve.
5. Close all previously opened vent valves.



If fluid containing glycol was added to the system circuit, make sure it is recovered and disposed of in accordance with standard EN 1717.

2.10 EMPTYING THE D.H.W. CIRCUIT

To do this, always close the domestic cold water inlet upstream of the appliance.
Open any domestic hot water tap to discharge the pressure from the circuit.
Empty the storage tank completely as indicated in Par. 2.11

2.11 STORAGE TANK DRAINING

To drain the storage tank, use the relevant storage tank draining valve (Det. 1, Fig. 30).



Before performing this operation, close the cold water inlet valve and open any DHW system hot water valve in order to allow the inlet of air into the storage tank.

2.12 CLEANING THE CASE

1. Use damp cloths and neutral detergent to clean the Indoor Unit casing.



Never use abrasive or powder detergents.

2.13 PERMANENT SHUTDOWN

Should the system be shut down permanently, have professional staff carry out the procedures, making sure that the electrical and water supply lines have been previously shut off.



3 INSTRUCTIONS FOR MAINTENANCE AND INITIAL CHECK

3.1 GENERAL RECOMMENDATIONS

INSTALLER



Operators who install and service the appliance must wear the personal protective equipment (PPE) required by applicable law.
The list of possible PPE is not complete as they are indicated by the employer.

USER



Before carrying out any maintenance work, make sure that:

- you have disconnected the power to the appliance;
- you have discharged the pressure from the system and domestic hot water circuit.



Supply of spare parts

The device's warranty shall be rendered null and void if unapproved or unsuitable parts are used for maintenance or repairs. These will also compromise the product's compliance, and the said product may no longer be valid and fail to meet the current regulations. In regard to the above, only use original Immergas spare parts when replacing components.



If additional documentation needs to be consulted for extraordinary maintenance, contact the Authorised After-Sales Service.

MAINTENANCE TECHNICIAN



The appliance operates with R32 refrigerant gas.
This gas is ODOURLESS.
Pay the utmost attention
Strictly follow the instruction handbook of the Outdoor Unit before installation and any type of operation on the chiller circuit.



R32 refrigerant gas belongs to the low flammability refrigerant category: class A2L according to standard ISO 817. It guarantees high performance with low environmental impact. The new gas reduces the potential environmental impact by one third compared to R410A, having less effect on global warming (GWP 675).

TECHNICAL DATA



3.2 INITIAL CHECK

To commission the package, you must:

- Check connection to a 230V~50Hz power mains, correct L-N polarity and the earthing connection;
- make sure the central heating system is filled with water and the indoor unit pressure gauge reads a pressure of 1-1.2 bar;
- make sure the chiller circuit has been filled according to what is described in the outdoor unit instructions booklet;
- check the activation of the main switch located upstream of the indoor unit;
- ensure activation of all adjustment devices;
- ensure production of domestic hot water;
- check the tightness of the hydraulic circuits;



Even if just one single safety check provides a negative result, do not commission the system.

3.3 YEARLY APPLIANCE CHECK AND MAINTENANCE



The following checks and maintenance should be performed once a year to ensure operation, safety and efficiency of the appliance over time.

- Check for water leaks or oxidation from/on the fittings.
- Check, after discharging the system pressure and bringing it to zero (read on indoor unit pressure gauge), that the expansion vessel charge is at 1.0 bar.
- Check that the system static pressure (with system cold and after refilling the system by means of the filling valve) is between 1 and 1.2 bar.
- Check the pressure of the two 2x12L DHW vessels.
- Visually check that the safety and control devices have not been tampered with and/or short-circuited.
- Check the condition and integrity of the electrical system and in particular:
 - The power cables must be inside the cable fixings;
 - There must be no traces of blackening or burning.
- Check correct lighting and operation.
- Check correct operation of control and adjustment devices and in particular:
 - system regulation probes intervention.
- Check chiller line connections.
- Check mesh filter on system return.
- Check the correct flow rate on plate heat exchanger.
- Check the integrity of the internal insulation.



In addition to yearly maintenance, one must also check the energy efficiency of the thermal system, with frequency and procedures that comply with the indications of the technical regulations in force.



3.4 FINNED AIR COIL MAINTENANCE



We recommend regularly inspecting the finned air coils to check the level of fouling.

INSTALLER

This depends on the environment where the unit is installed.

The level of fouling will be worse in urban and industrial sites, as well as near trees that lose their leaves.

There are two maintenance levels to clean the coils:

- If the air heat exchangers are encrusted, clean them gently with a brush in a vertical direction.
- Turn off the fans before working on the air heat exchangers.
- To perform this type of intervention, stop the unit only if the maintenance considerations allow it.
- Perfectly clean air heat exchangers ensure an optimal operation of the unit. When the air heat exchangers begin to encrust, they must be cleaned. The cleaning frequency depends on the season and location of the unit (ventilated, wooded, dusty, etc.).
- Do not use pressurised water without a large diffuser. Do not use high-pressure cleaners for Cu/Cu and Cu/Al air coils.
- Concentrated and/or rotating water jets are strictly prohibited. Never use fluid with a temperature above 45°C to clean the air heat exchangers.
- Proper and frequent cleaning (approx. every three months) prevents 2/3 of corrosion problems.

Clean the air coil using suitable products.

USER

MAINTENANCE TECHNICIAN

TECHNICAL DATA



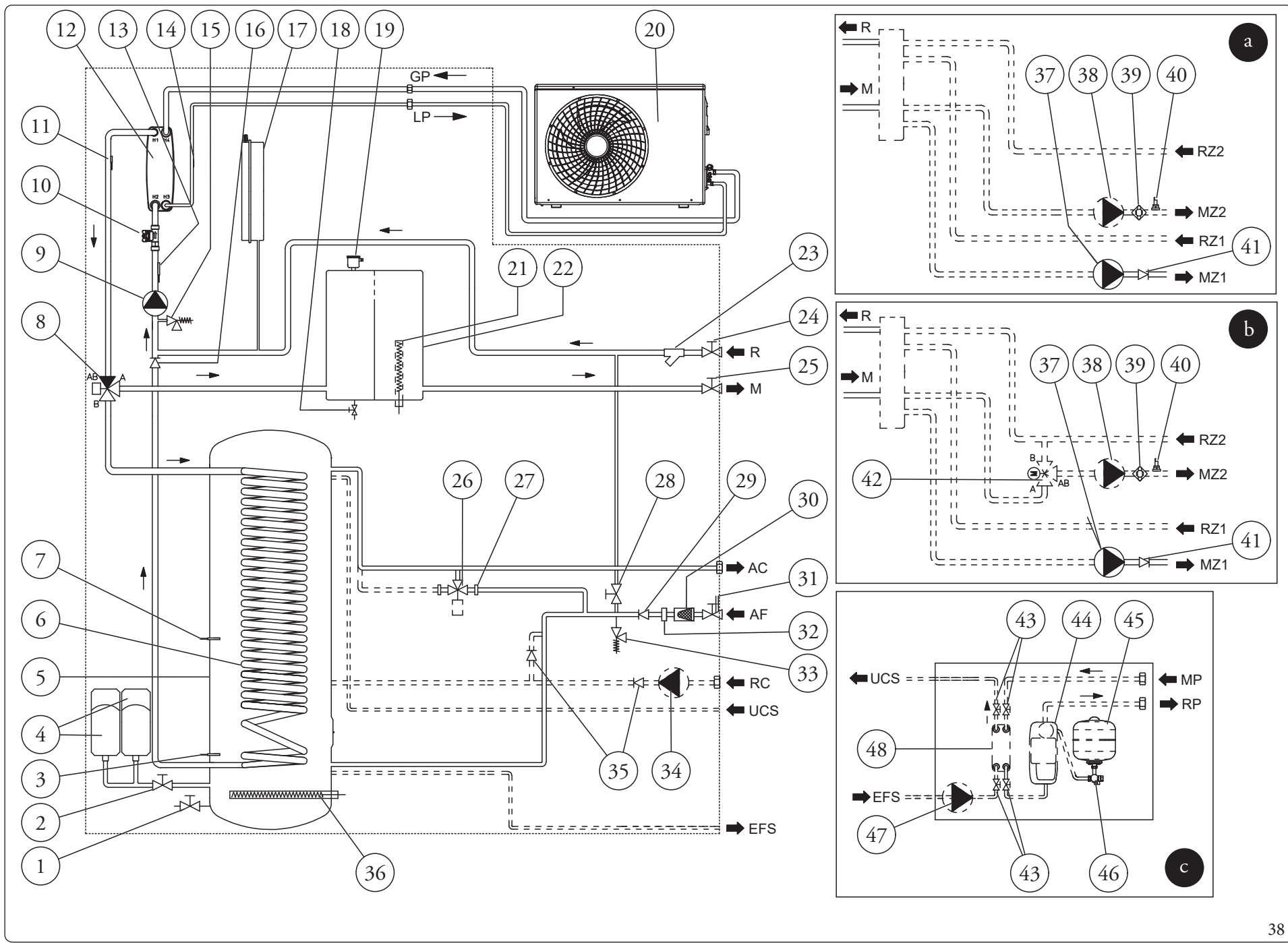

ST.007399/005

MAGIS HERCULES PRO MINI 6/9 EH

75



TECHNICAL DATA

MAINTENANCE TECHNICIAN

USER

INSTALLER

Key (Fig. 38):

- | | | | | | |
|----|---|--|-----|---|---|
| 1 | - | Storage tank draining valve | 34 | - | DHW recirculation pump (Optional) |
| 2 | - | DHW expansion vessel valve | 35 | - | DHW recirculation one-way valve (Optional) |
| 3 | - | Storage tank solar probe (Optional) | 36 | - | DHW electrical resistance |
| 4 | - | Domestic hot water expansion vessel | 37 | - | Direct zone 1 pump (Optional) |
| 5 | - | Stainless steel storage tank | 38 | - | Zone 2 circulator (Optional) |
| 6 | - | Stainless steel coil for storage tank | 39 | - | Zone 2 safety thermostat (Optional) |
| 7 | - | D.H.W. probe | 40 | - | Zone 2 low-temperature flow probe (Optional) |
| 8 | - | 3-way valve (motorised) | 41 | - | One-way valve |
| 9 | - | Heat pump circulator | 42 | - | Zone 2 mixing valve (Optional) |
| 10 | - | System flow-meter | 43 | - | Solar shut-off valves (Optional) |
| 11 | - | Heat pump flow probe | 44 | - | Single solar circulation unit (Optional) |
| 12 | - | Plate heat exchanger | 45 | - | Solar expansion vessel (Optional) |
| 13 | - | Heat pump return probe | 46 | - | Shut-off valve with solar system thermometer (Optional) |
| 14 | - | Liquid phase detection probe | 47 | - | Solar pump (Optional) |
| 15 | - | 3 bar safety valve | 48 | - | Solar system plate heat exchanger (Optional) |
| 16 | - | Non-return valve | R | - | System return |
| 17 | - | System expansion vessel | M | - | System flow |
| 18 | - | System draining valve | RZ1 | - | Direct zone 1 system return (Optional) |
| 19 | - | Air vent valve | MZ1 | - | Direct zone 1 system flow (Optional) |
| 20 | - | Outdoor unit Audax Pro V2 | RZ2 | - | Direct zone 2 system return (Optional) |
| 21 | - | System electrical resistance | MZ2 | - | Direct zone 2 system flow (Optional) |
| 22 | - | Inertial storage tank | AC | - | Domestic hot water outlet |
| 23 | - | Filter that can be inspected | AF | - | Domestic cold water inlet |
| 24 | - | System return shut-off valve (Optional) | RC | - | Recirculation (Optional) |
| 25 | - | System flow shut-off valve (Optional) | MP | - | Flow from solar panels (Optional) |
| 26 | - | Solar system DHW mixing valve (Optional) | RP | - | Return to solar panels (Optional) |
| 27 | - | Cap for solar kit installation | GP | - | Chiller line - gaseous phase |
| 28 | - | System filling valve | LP | - | Chiller line - liquid phase |
| 29 | - | Cold water inlet non-return valve | a | - | 2 direct zones kit (Optional) |
| 30 | - | Cold water filter | b | - | 2 zone kit (1 direct and 1 mixed) (Optional) |
| 31 | - | Cold water inlet valve | c | - | Solar kit (Optional) |
| 32 | - | Flow limiter | | | |
| 33 | - | 8 bar safety valve | | | |



3.6 WIRING DIAGRAM

X109 Terminal board connections diagram

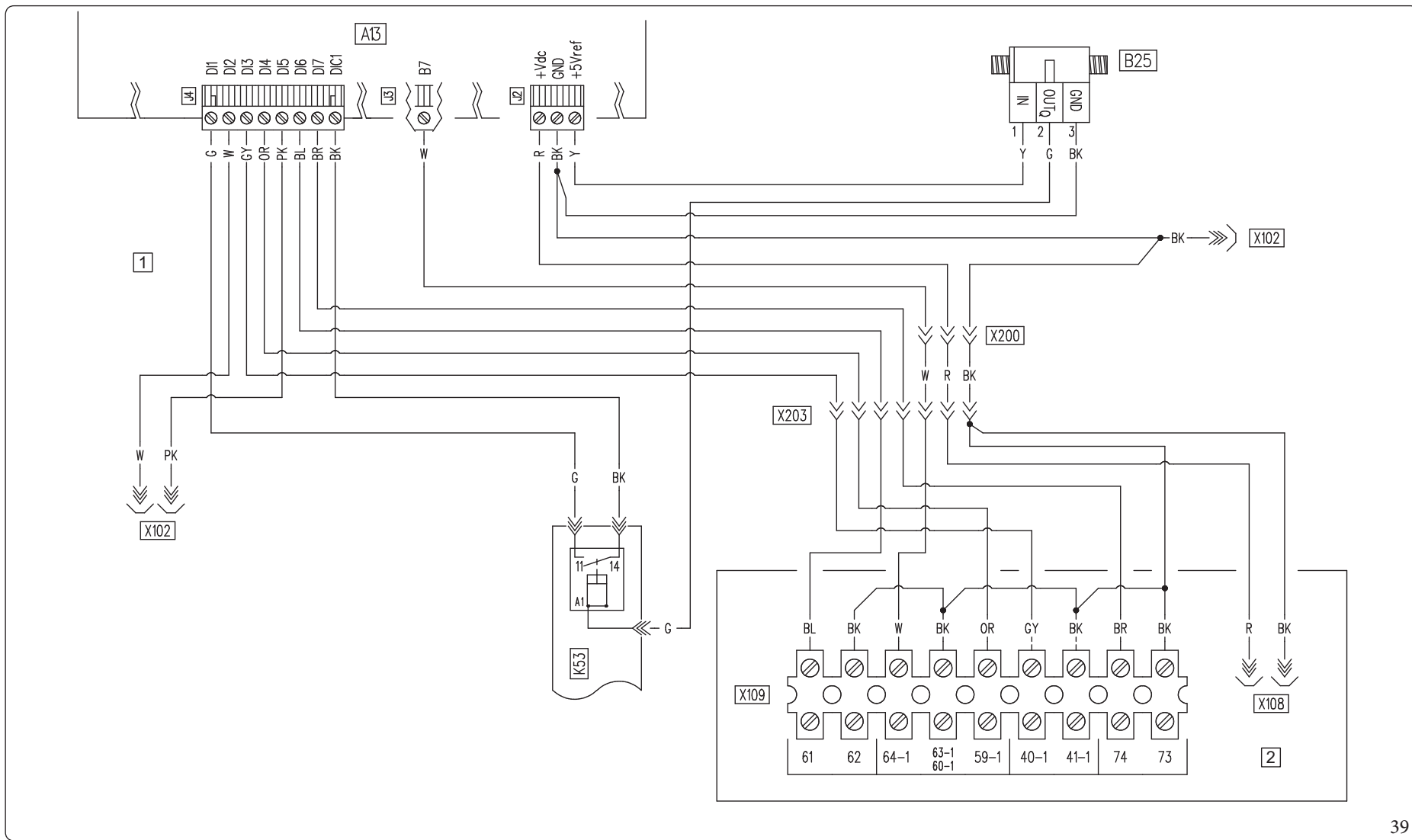

39

Key (Fig. 39):

- A13 - Supervision board
- B25 - System flow-meter
- K53 - Flowmeter Signal conversion relay
- 1 - Main panel
- 2 - Control panel

- BK - Black
- BL - Blue
- BR - Brown
- CY - Cyan
- G - Green
- GY - Grey
- G/Y - Yellow/Green

- W/BK - White/Black
- OR - Orange
- P - Purple
- PK - Pink
- R - Red
- W - White
- Y - Yellow



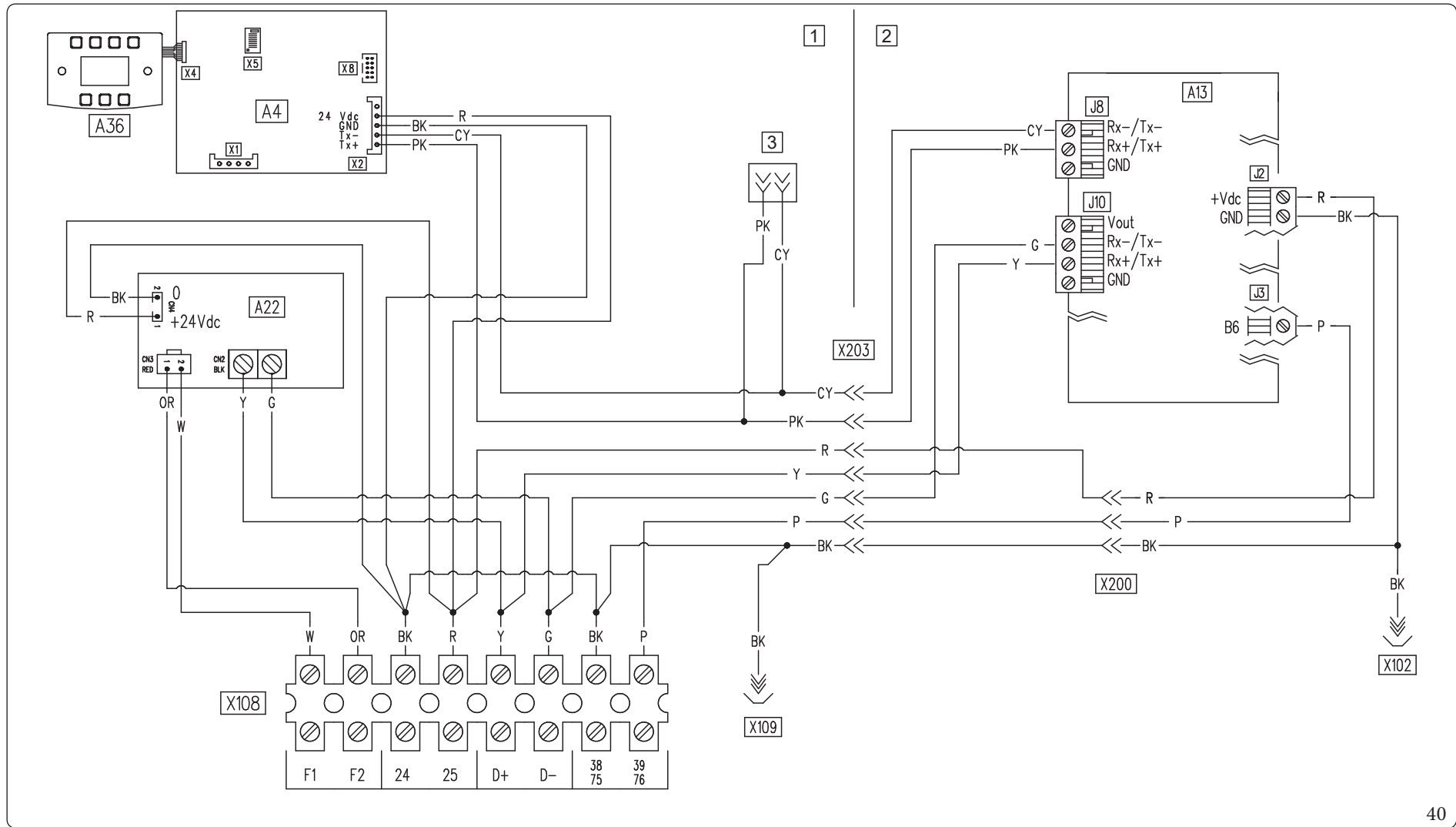

Key (Fig. 40):

- A4 - Displayboard
- A13 - Supervision board
- A22 - Condensing unit interface board
- A36 - Touch keyboard
- 1 - Control panel
- 2 - Main panel
- 3 - Test connector

- BK - Black
- BL - Blue
- BR - Brown
- CY - Cyan
- G - Green
- GY - Grey
- OR - Orange
- P - Purple

- PK - Pink
- R - Red
- W - White
- Y - Yellow

X105 Terminal board connections diagram

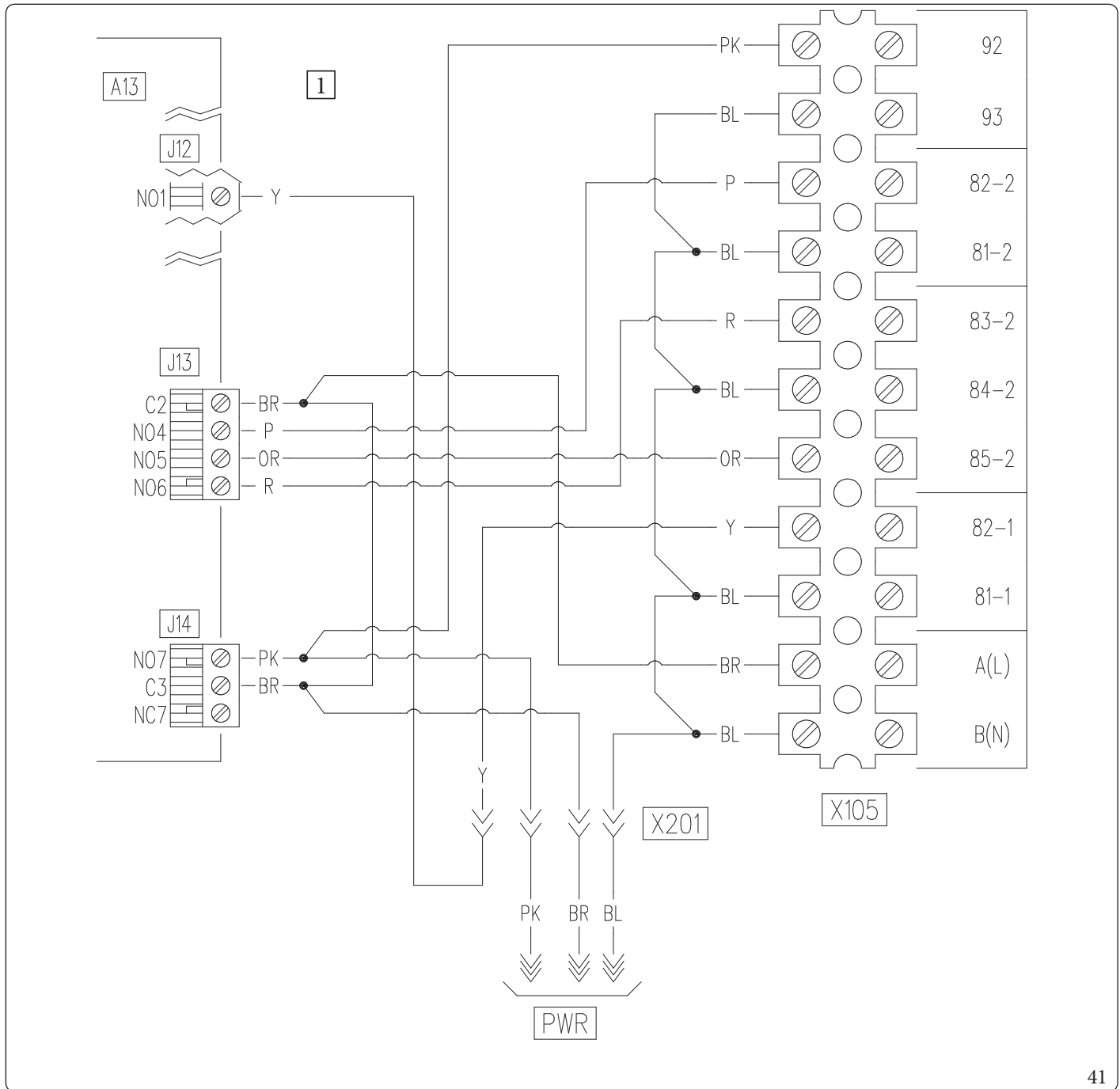

INSTALLER

USER

MAINTENANCE/TECHNICIAN

TECHNICAL DATA

Key (Fig. 41):

- A13 - Supervision board
- 1 - Main panel

- BL - Blue
- BR - Brown
- OR - Orange
- P - Purple
- PK - Pink
- R - Red
- Y - Yellow



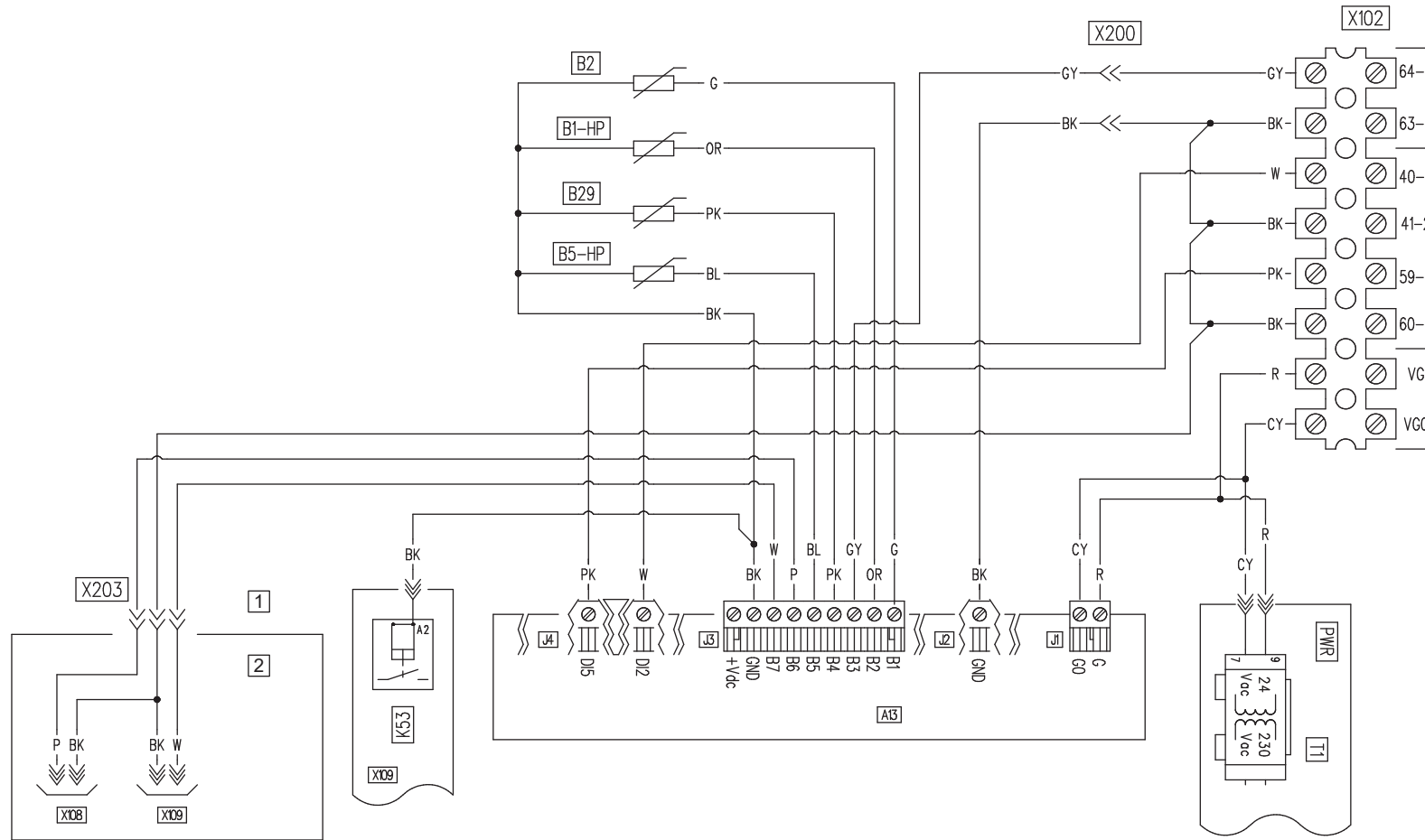

Key (Fig. 42):

- A13 - Supervision board
- B1-HP - Flow probe
- B2 - D.H.W. probe
- B5-HP - Return probe
- B29 - Liquid phase probe
- K53 - Flow meter Signal conversion relay
- T - Transformer

- 1 - Main panel
- 2 - Control panel

- BK - Black
- BL - Blue
- BR - Brown
- CY - Cyan
- G - Green
- GY - Grey
- OR - Orange
- P - Purple
- PK - Pink
- R - Red
- W - White



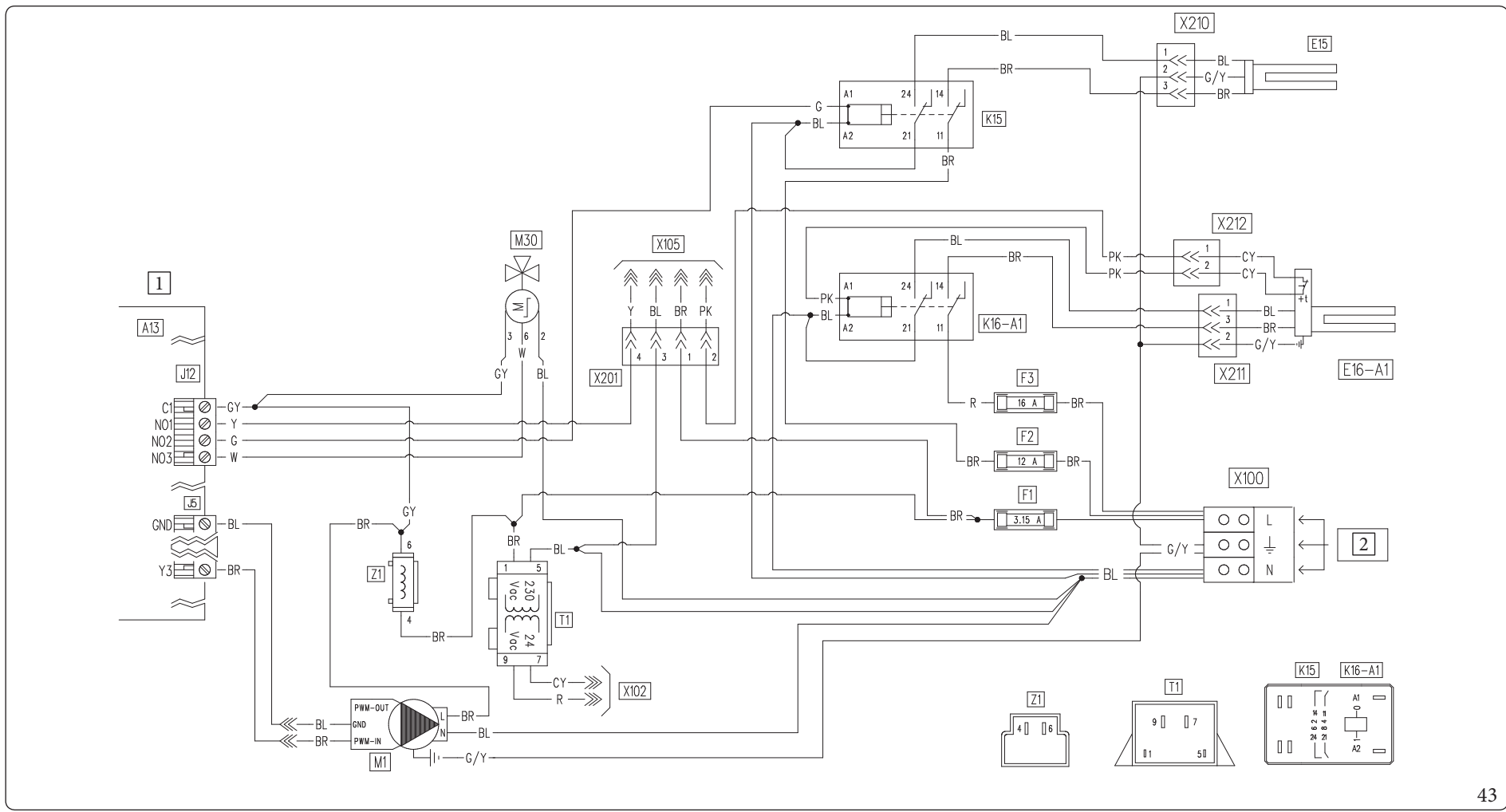

Key (Fig. 43):

- A13 - Supervision board
- E15 - Domestic hot water integration resistance
- E16-A1 - Internal system integrative resistance
- F1 - Control Phase fuse (3,15 F 250 V 5x20)
- F2 - DHW Integrative Resistance Phase Fuse (12A aM 500V CH10)
- F3 - Internal system integrative Resistance Phase Fuse (16A aM 500V CH10)
- K15 - DHW integrative resistance relay

- K16-A1 - Internal system integrative resistance relay
- M1 - Heat pump circulator
- M30 - DHW (Domestic hot water) diverter
- T1 - Transformer
- Z1 - Antijamming filter
- 1 - Main panel
- 2 - 230 Vac, 50 Hz, 4 mm²

- BL - Blue
- BR - Brown
- CY - Cyan
- G - Green
- GY - Grey
- G/Y - Yellow/Green
- R - Red
- W - White
- Y - Yellow



Interface board - setting switch

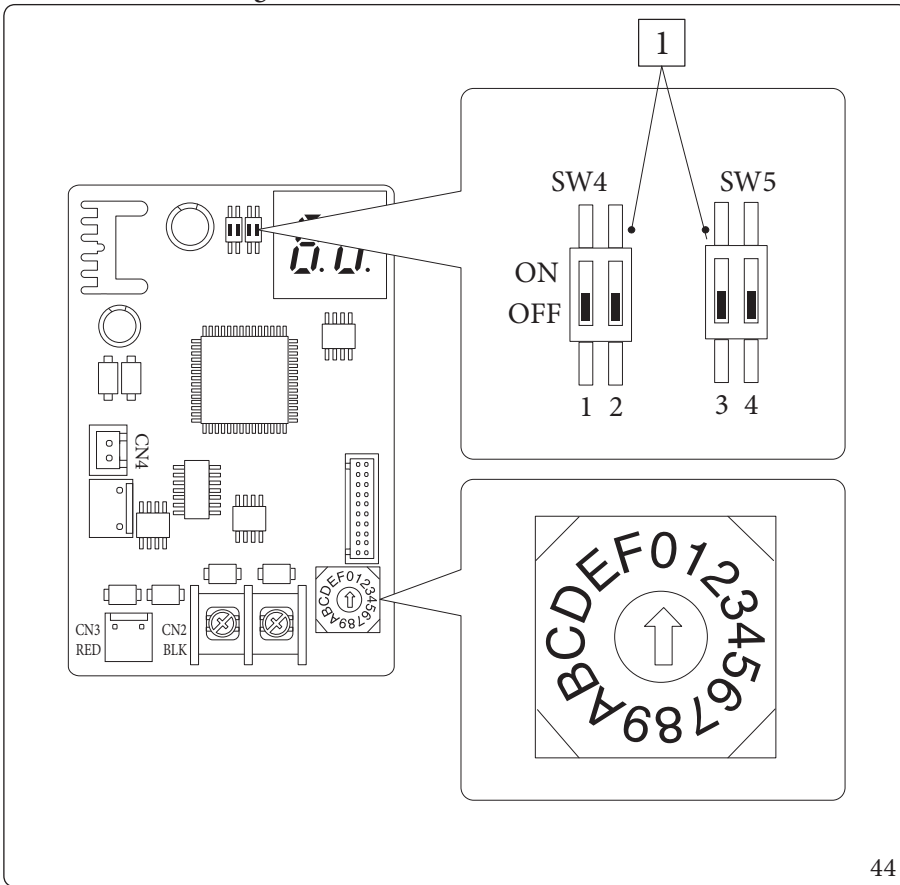

Key (Fig. 44):

1 - Factory setting: do not change



Interfaceboard - indicator LED

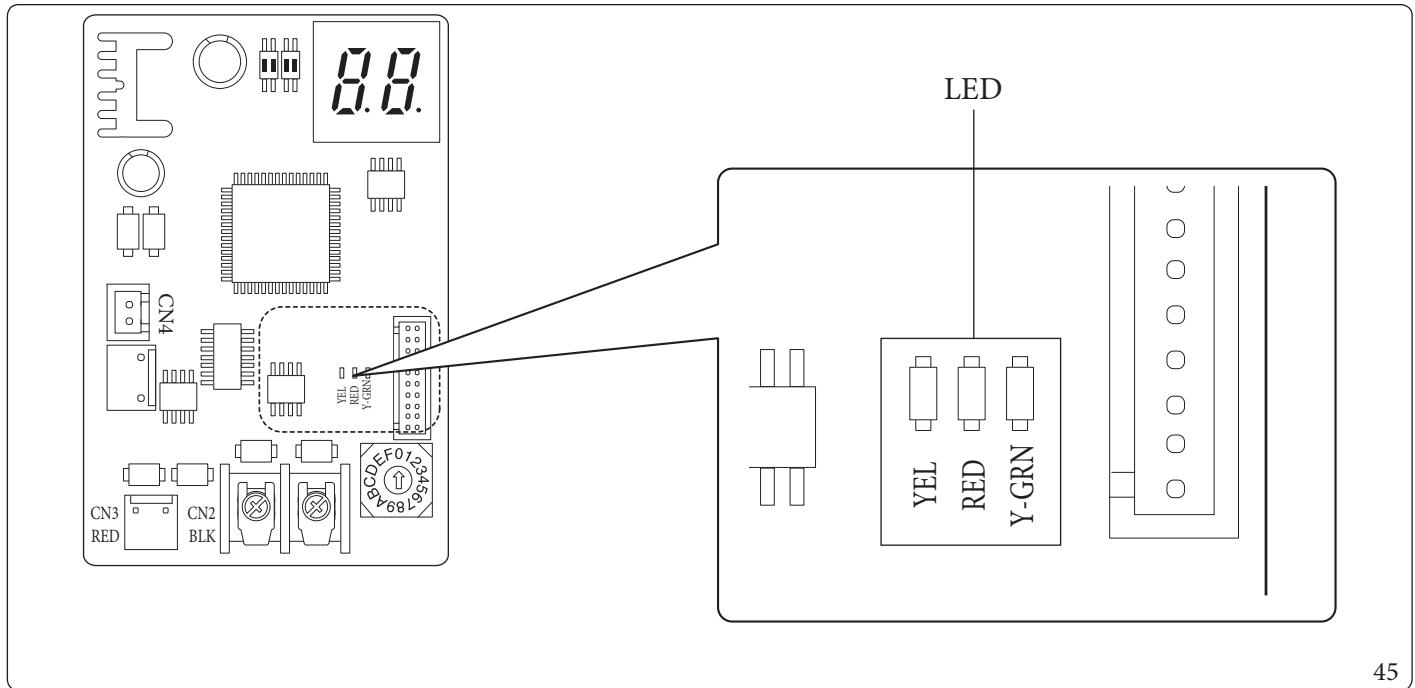

Key (Fig. 45):

Red LED flashing = Communication between interface board and P.C.B. valid

Green LED flashing = Communication between interface board and Outdoor Unit valid

Yellow LED = Not Used

Interface board - 7-segment display

During normal operation, the display shows "A0" for 1 second, followed by "30" for 1 second:

	SEGMENTS
VALID COMMUNICATION	

In case of an error of the Outdoor Unit, a sequence of two digits at a time is displayed: "E" plus Outdoor Unit error code:

ERROR CODES	SEGMENTS
E101	

INSTALLER

USER

MAINTENANCE TECHNICIAN

TECHNICAL DATA



3.7 SYSTEM FILTER

The unit is sold with a filter that must be installed on the system return pipe in order to preserve the proper functioning of the system. The filter can be cleaned periodically and when necessary.



In order to preserve the proper functioning of the plate heat exchanger within the hydraulic circuit, it is necessary for the inspection Y-filter to work in a horizontal position.

3.8 TROUBLESHOOTING



Maintenance operations must be carried out by an authorised company (e.g. Authorised After-Sales Technical Assistance Centre).

Noise due to air in the system.

Check the correct deaeration of the system.

Make sure the system pressure and expansion tank factory-set pressure values are within the set limits.

The factory-set pressure values of the expansion vessel must be 1.0 bar, the value of system pressure must be between 1 and 1.2 bar.



3.9 P.C.B. PROGRAMMING

The water heater is set up for possible programming of the operation parameters. By modifying these parameters as described below, the system can be adapted according to specific needs.

To view the advanced functioning parameters of "DHW" menu you need to enter the "General information" sub-menu and select "Access level", enter the access code and confirm with "OK" (Fig. 31).

Select "**Login type = Service**", press "OK" and go back to the main screen using "RESET".

Enter the "DHW" menu and adjust the parameters below as needed.

To save the parameter change, press the "OK" button (Fig. 31).

Exit the menu with type "User" access, waiting the 4 minutes of inactivity or re-entering the "General settings" submenu and select "Access level", enter the correct code, confirm with "OK" and select "**Login type = User**", press "OK" to confirm.

DHW	
Menu item	Description
Anti-legionella	Manages the anti-legionella function.
Configuration	DHW (Domestic hot water) configuration parameters

DHW / Anti-legionella				
Menu item	Description	Range	Default	Customised value
Anti-legion.cycle time	Establishes the time of activation of the anti-legionella function.	00:00 – 23:59	02:00	
Anti-legion.cycle day	Establishes the day of activation of the anti-legionella function.	None / Monday - Sunday / All	None	
Max antilegion. time	Time after which an alarm is signalled for incomplete anti-legionella cycle.	1 - 48 (h)	3h	

DHW / Configuration				
Menu item	Description	Range	Default	Customised value
DHW hysteresis	The system activation temperature in DHW (Domestic hot water) is given by the set DHW (Domestic hot water) – DHW (Domestic hot water) hysteresis	1 ÷ 12 °C	5 °C	
DHW flow offset	The DHW (Domestic hot water) flow temperature is given by the DHW (Domestic hot water) set + DHW (Domestic hot water) flow offset	5 - 55 °C	10 °C	
Priority	In case of simultaneous heat./cool. system and DHW request, the heat pump will give priority to DHW or to the system.	DHW / CH	DHW	
Max time DHW	Time after which an alarm is signalled for incomplete DHW (Domestic hot water).	1 - 48 (h)	5h	



To view the advanced operating parameters of the "Zones" "menu", enter the "General settings" submenu, select "Access level" and then select "**Login type = Service**" and enter the specific password, press "OK" and go back to the main screen using the "RESET" key. Select "**Login type = Service**", press "OK" and go back to the main screen using "RESET". Enter the "Zones" menu and adjust the parameters described below as needed. To save the parameter change, press the "OK" button (Fig. 31). Exit the menu with type "Service" access, waiting the 4 minutes of inactivity or re-entering the "General settings" submenu and select "User", enter the correct code, confirm with "OK" and select "**Login type = User**", press "OK" to confirm.

Zones/Zone 1/Configuration	
Menu item	Description
Enablings	
Thermoreg. CH	Central heating thermoregulation setting sub-menu
Thermoreg. Cool.	Cooling thermoregulation setting sub-menu

Zones/Zone 1/Configuration/Enablings				
Menu item	Description	Range	Default	Customised value
Mode	Establishes the zone 1 operating mode	CH Cool. Cool+CH	Cool+CH	
Enable remote contr.	Enables the operation of a remote device. - No = No remote control installed - Panel = Remote zone control - Probe = Temperature and humidity probe	No Panel Probe	No	
Room. probe modul.	Enables modulation with room probe	Yes/No	Yes	
Enable room thermostat	Enable operation of a room thermostat to check the zone	Yes/No	Yes	
Enable dewpoint	In the presence of a remote device, calculation of the dew point. The calculation is particularly needed in case of radiant panel systems.	Yes/No	Yes	
Enable humidistat	Enables the operation of a humidistat	No/Yes	No	
Enable dehumidifiers	Enables the operation of a dehumidifier	Yes/No	No	
Max dehum. temp.	Maximum flow temperature acceptable for the dehumidifier, beyond which it is kept switched off.	10 - 50 °C	25 °C	
Dehum. alarm set	Maximum flow set calculated, acceptable by the dehumidifier.	10 - 50 °C	25 °C	
Ext. probe modul.	Thermoregulation with external probe	No/Yes	No	



Zones / Zone 1 / Configuration / **Thermoreg. CH**

Menu item	Description	Range	Default	Customised value
Max flow set	Without the external probe it defines the maximum flow temperature that can be set by the user. With the external probe present it defines the maximum flow temperature corresponding to operation with minimum external temperature	20 ÷ 65°C	55°C	
Min flow set	Without the external probe it defines the minimum flow temperature that can be set by the user. With the external probe present it defines the minimum flow temperature corresponding to operation with maximum external temperature	20 ÷ 65°C	20°C	
Min. outside temp.	With the external probe present it defines at what minimum external temperature the system must operate at the maximum flow temperature	-25 ÷ +15°C	-5°C	
Max. outside temp.	With the external probe present it defines at what maximum external temperature the system must operate at the minimum flow temperature	-5 ÷ +45°C	25°C	

INSTALLER

Zones / Zone 1 / Configuration / **Thermoreg. Cool.**

Menu item	Description	Range	Default	Customised value
Max flow set	Without the external probe it defines the maximum flow that can be set by the user. With the external probe present it defines the maximum flow temperature corresponding to operation with minimum external temperature	5 ÷ 25°C	20°C	
Min flow set	Without the external probe it defines the minimum flow that can be set by the user. With the external probe present it defines the minimum flow temperature corresponding to operation with maximum external temperature	5 ÷ 25°C	7°C	
Min. outside temp.	With the external probe present, it defines at what maximum external temperature the system must operate at the minimum flow temperature	20 ÷ 45°C	25°C	
Max. outside temp.	With the external probe present, it defines at what minimum external temperature the system must operate at the maximum flow temperature	20 ÷ 45°C	35°C	

USER

MAINTENANCE/TECHNICIAN

TECHNICAL DATA



Zones/Zone 2(*)/Configuration	
Menu item	Description
Enablings	
Thermoreg. CH	Central heating thermoregulation setting sub-menu
Thermoreg. Cool.	Cooling thermoregulation setting sub-menu

(*) if present.

Zones/Zone 2(*)/Configuration/Enablings				
Menu item	Description	Range	Default	Customised value
Mode	Establishes the zone 2 operating mode	CH Cool. Cool+CH	Cool+CH	
Enable remote contr.	Enables the operation of a remote device. - No = No remote control installed - Panel = Remote zone control - Probe = Temperature and humidity probe	No Panel Probe	No	
Room. probe modul.	Enables modulation with room probe	Yes/No	Yes	
Enable room thermostat	Enable operation of a room thermostat to check the zone	Yes/No	Yes	
Enable dew point	In the presence of a remote device, calculation of the dew point. The calculation is particularly needed in case of radiant panel systems.	Yes/No	Yes	
Enable humidistat	Enables the operation of a humidistat	No/Yes	No	
Enable dehumidifiers	Enables the operation of a dehumidifier	Yes/No	No	
Max dehum. temp.	Maximum flow temperature acceptable for the dehumidifier, beyond which it is kept switched off.	10 - 50 °C	25 °C	
Dehum. alarm set	Maximum flow set calculated, acceptable by the dehumidifier.	10 - 50 °C	25 °C	
Ext. probe modul.	Thermoregulation with external probe	No/Yes	No	

(*) if present.



Zones/Zone 2(*)/Configuration/Thermoreg. CH

Menu item	Description	Range	Default	Customised value
Max flow set	Without the external probe it defines the maximum flow temperature that can be set by the user. With the external probe present it defines the maximum flow temperature corresponding to operation with minimum external temperature	20 ÷ 65°C	45°C	
Min flow set	Without the external probe it defines the minimum flow temperature that can be set by the user. With the external probe present it defines the minimum flow temperature corresponding to operation with maximum external temperature	20 ÷ 65°C	25°C	
Min. outside temp.	With the external probe present it defines at what minimum external temperature the system must operate at the maximum flow temperature	-25 ÷ +15°C	-5°C	
Max. outside temp.	With the external probe present it defines at what maximum external temperature the system must operate at the minimum flow temperature	-5 ÷ +45°C	25°C	

(*) if present.

Zones/Zone 2(*)/Configuration/Thermoreg. Cool.

Menu item	Description	Range	Default	Customised value
Max flow set	Without the external probe it defines the maximum flow that can be set by the user. With the external probe present it defines the maximum flow temperature corresponding to operation with minimum external temperature	5 ÷ 25°C	20°C	
Min flow set	Without the external probe it defines the minimum flow that can be set by the user. With the external probe present it defines the minimum flow temperature corresponding to operation with maximum external temperature	5 ÷ 25°C	18°C	
Min. outside temp.	With the external probe present, it defines at what maximum external temperature the system must operate at the minimum flow temperature	20 ÷ 45°C	25°C	
Max. outside temp.	With the external probe present, it defines at what minimum external temperature the system must operate at the maximum flow temperature	20 ÷ 45°C	35°C	

(*) if present.

INSTALLER

USER

MAINTENANCE/TECHNICIAN

TECHNICAL DATA



Zones/Zone 3(*)/Configuration	
Menu item	Description
Enablings	
Thermoreg. CH	Central heating thermoregulation setting sub-menu
Thermoreg. Cool.	Cooling thermoregulation setting sub-menu

(*) if present.

Zones/Zone 3(*)/Configuration/Enablings				
Menu item	Description	Range	Default	Customised value
Mode	Establishes the zone 3 operating mode	CH Cool. Cool+CH	Cool+CH	
Enable remote contr.	Enables the operation of a remote device. - No = No remote control installed - Panel = Remote zone control - Probe = Temperature and humidity probe	No Panel Probe	No	
Room. probe modul.	Enables modulation with room probe	Yes/No	Yes	
Enable room thermostat	Enable operation of a room thermostat to check the zone	Yes/No	Yes	
Enable dew point	In the presence of a remote device, calculation of the dew point. The calculation is particularly needed in case of radiant panel systems.	Yes/No	Yes	
Enable humidistat	Enables the operation of a humidistat	No/Yes	No	
Enable dehumidifiers	Enables the operation of a dehumidifier	Yes/No	No	
Max dehum. temp.	Maximum flow temperature acceptable for the dehumidifier, beyond which it is kept switched off.	10 - 50 °C	25 °C	
Dehum. alarm set	Maximum flow set calculated, acceptable by the dehumidifier.	10 - 50 °C	25 °C	
Ext. probe modul.	Thermoregulation with external probe	No/Yes	No	

(*) if present.



Zones/Zone 3 (*)/Configuration/Thermoreg. CH

Menu item	Description	Range	Default	Customised value
Max flow set	Without the external probe it defines the maximum flow temperature that can be set by the user. With the external probe present it defines the maximum flow temperature corresponding to operation with minimum external temperature	20 ÷ 65°C	45°C	
Min flow set	Without the external probe it defines the minimum flow temperature that can be set by the user. With the external probe present it defines the minimum flow temperature corresponding to operation with maximum external temperature	20 ÷ 65°C	25°C	
Min. outside temp.	With the external probe present it defines at what minimum external temperature the system must operate at the maximum flow temperature	-25 ÷ +15°C	-5°C	
Max. outside temp.	With the external probe present it defines at what maximum external temperature the system must operate at the minimum flow temperature	-5 ÷ +45°C	25°C	

(*) if present.

Zones/Zone 3 (*)/Configuration/Thermoreg. Cool.

Menu item	Description	Range	Default	Customised value
Max flow set	Without the external probe it defines the maximum flow that can be set by the user. With the external probe present it defines the maximum flow temperature corresponding to operation with minimum external temperature	5 ÷ 25°C	20°C	
Min flow set	Without the external probe it defines the minimum flow that can be set by the user. With the external probe present it defines the minimum flow temperature corresponding to operation with maximum external temperature	5 ÷ 25°C	18°C	
Min. outside temp.	With the external probe present, it defines at what maximum external temperature the system must operate at the minimum flow temperature	20 ÷ 45°C	25°C	
Max. outside temp.	With the external probe present, it defines at what minimum external temperature the system must operate at the maximum flow temperature	20 ÷ 45°C	35°C	

(*) if present.

INSTALLER

USER

MAINTENANCE/TECHNICIAN

TECHNICAL DATA



To access the "Support" menu, press the "MENU" button (Fig. 31). Go to the submenu "General settings" and select "Access level". Insert the relative access code and customise the parameters described below according to your requirements. To save the change of the parameters described below, press the "OK" button (Fig. 31). Exit the "Support" menu waiting 4 minutes or enter the appropriate access code for the "User" menu. You can exit the assistance menu by entering the appropriate access code under the "Access level" item and selecting the item

Login type / User

At the end, press "OK" to confirm.
After 4 minutes without setting any changes within the "Support" menu, the system automatically returns to the "User" menu.

Menu / General settings		
Menu item	Description	Range
Factory setting	Allows to reset all parameters with factory values.	Yes/No

Menu / Support	
Menu item	Description
System definition	Sub-menu to define the devices connected to the system
Heat pump	Heat pump operating parameters sub-menu
Integration	System integration setting sub-menu
Manual drives	Submenu for load operation check
Special parameters	Parameters for various uses



Menu/Support/System definition				
Menu item	Description	Range	Default	Customised value
Number of zones	Defines the number of zones present	1-3	1	
Main zone	Defines the main zone of the system in which the remote panel will be used	1-2-3	1	
External probe (*)	This defines the type of external probe enabled. - IU = indoor unit - OU = outdoor unit.	OU / IU	OU	
External probe corr.	Correction of the external probe value	-9 +9	0	
Photovoltaic function	Enables the operation combined with a photovoltaic system.	Yes/No	No	
System supervision	Enabling connection to Dominus or System supervisor	No/Domin/BMS	No	
Activation time	Waiting time before activation of the system setpoint correction	1 - 120	20	
Increase time	Time interval for the increase or decrease of 1°C of correction of the system setpoint	1 - 20	5	
Max CH adjust	Max correction during central heating mode	0 - 10	0	
Max Cool. adjust	Max correction during cooling mode.	0 - 10	0	
Multifunction relay 1	0 = Disabled. 1 = Zone 1 in neutral air dehumidification contact. 2 = Zone 2 in neutral air dehumidification contact. 3 = Zone 1 in cooled air dehumidification contact. 4 = Zone 2 in cooled air dehumidification contact. 5 = Summer/Winter valve contact. 6 = DHW/System valve contact 7 = Recirculation pump contact.	0 - 10	0	
Multifunction relay 2	0 = Disabled. 1 = Zone 1 in neutral air dehumidification contact. 2 = Zone 2 in neutral air dehumidification contact. 3 = Zone 1 in cooled air dehumidification contact. 4 = Zone 2 in cooled air dehumidification contact. 5 = Summer/Winter valve contact. 6 = DHW/system valve contact. 7 = Recirculation pump contact.	0 - 10	0	
Multifunction relay 3	0 = Disabled. 1 = Zone 1 in neutral air dehumidification contact. 2 = Zone 2 in neutral air dehumidification contact. 3 = Zone 1 in cooled air dehumidification contact. 4 = Zone 2 in cooled air dehumidification contact. 5 = Summer/Winter valve contact. 6 = DHW/System valve contact 7 = Recirculation pump contact. 8 = Not used 9 = Zone 3 in neutral air dehumidification contact. 10 = Zone 3 in cooled air dehumidification contact.	0 - 10	0	

(*) It is not possible to use the external probe IU (optional) when using DHW recirculation.

INSTALLER

USER

MAINTENANCE TECHNICIAN

TECHNICAL DATA



Menu/Support/Heat pump	
Menu item	Description
HP Type	
Powers	
Timers	
Meters	

Menu/Service/Heat pump/HP Type				
Menu item	Description	Range	Default	Customised value
HP Type	Setting the indoor unit.	MHP / MHP Mini	MHP Mini	

Menu/Support/Heat pump/Powers				
Menu item	Description	Range	Default	Customised value
HP Model	Setting the connected outdoor unit. Do not use the item "No".	No / 6 / 9	6	
HP power off	Enable the Disabling function of the heat pump. By selecting "Reduct.", it is possible to reduce the heat pump performance to the power set in the parameter "Power in reduced"	No / Yes / Reduct.	No	
Power in reduced	Power percentage in reduction mode.	10 ÷ 100 %	75 %	

Menu / Support / Heat pump / Timers				
Menu item	Description	Range	Default	Customised value
Anti-cycle time	Not used	0-840 s	180 s	
Ramp time	Not used	0-840 s	0 s	
Req. delay time TA	In the case of both the room thermostat and the Zone Panel, the request to the appliance occurs with a delay set with respect to the request to the zones.	0-600 s	0 s	
Prec. end wait time	Not used	0-100 s	0 s	



Menu/Support/Heat pump/Pump				
Menu item	Description	Range	Default	Customised value
Pump mode	Enable the pump operation with speed set "Max Sp." or the modulating mode with tracking of the modulating temperature ("Modul.") differential.	Max Sp. / Modul.	Max Sp.	
Min pump speed	Value of minimum speed used in modulating operation	20 – 100 %	100 %	
Max pump speed	Heat pump circulator speed	20 – 100 %	100 %	
Pump T Delta	Not used	2 – 20	5	
Automatic vent	Not used	No/Yes	No	

Menu/Support/Integration				
Menu item	Description	Range	Default	Customised value
Min. CH integr. temp.	Temperature threshold below which integration is activated at the heat pump in central heating.	-25 ÷ +35 °C (*)	-20 °C	
DHW integration mode.	Mode of intervention of the DHW (Domestic hot water) integration and resistance	Met. / Altern.	Altern.	
CH integration mode	Mode of intervention of the central heating / C.H. integration and resistance	Met. / Altern.	Altern.	
Concomitant mode	Enabling of conjunction function 0 = No 1 = C.H./Cool. 2 = Only Cool. 3 = C.H. only	0 - 3	0	
Enable DHW integr.	Enabling of generators for the DHW Mode	0 = HP 1 = HP-Int 2 = Int	HP	
Enable heat. integr.	Enabling of generators for the Central heating mode.	0 = HP 1 = HP-Int 2 = Int	HP	
CH wait time	Waiting time to reach the setting set before activation of the integration in room central heating / C.H.	20 ÷ 540'	60 min	
DHW wait time	Waiting time to reach the setting set before activation of the integration in the production of domestic hot water	20 ÷ 540'	120 min	
Time preceding DHW	Do not use	-	-	
Pre-heating time	Do not use	-	-	
Integration band	Setting of the activation band equal to the activation delay time will activate the additional heater.	1 - 20 °C	5 °C	
Reset HP meter	Reset the number of operating hours of the heat pump	Yes/No	No	
Reset plant int. met.	Reset hours of operation of the central heating / C.H. integration	Yes/No	No	
Reset sanitary int. met.	Reset hours of operation of the DHW (Domestic hot water) integration	Yes/No	No	

(*) For outdoor temperatures below -20°C, the capacity of the heat pump is not guaranteed.



If an additional electric resistance is installed and enabled for heating the system, it is necessary to check and, if necessary, change the pump settings to ensure a minimum flow rate of 1100l/h. Flow rate values below this limit can damage the resistance.

INSTALLER

USER

MAINTENANCE TECHNICIAN

TECHNICAL DATA



Menu/Support/ Manual drives (*)				
Menu item	Description	Range	Default	Customised value
Sys./DHW 3-way	Manual activation of the DHW (Domestic hot water) 3-way	Yes/No	No	
Enable sys.resistance	Manual activation of the system resistance	Yes/No	No	
Enable DHW resistance 1	Manual activation of the DHW (Domestic hot water) resistance 1	Yes/No	No	
Zone 1 circulator	Manual activation of zone 1 pump	Yes/No	No	
Dehumidifier zone 1	Manual activation of the dehumidifier in neutral air on zone 1	Yes/No	No	
Zone 1 air conditioning	Manual activation of the dehumidifier in cooled air on zone 1	Yes/No	No	
Zone 2 circulator	Manual activation of zone 2 pump	Yes/No	No	
Dehumidifier zone 2	Manual activation of the dehumidifier in neutral air on zone 2	Yes/No	No	
HP Flowmeter	Shows the flow rate read on the flowmeter	0-4000l/h		
Circulator speed		0-100%	0%	
Mixer zone 2	Manual activation of the mixing valve on zone 2	Stop Close Open	Stop	
Zone 2 air conditioning	Manual activation of the dehumidifier in cooled air on zone 2	Yes/No	No	
Zone 3 mixing valve	Manual activation of the mixing valve on zone 3	Stop Close Open	Stop	
Zone 3 circulator	Manual activation of zone 3 pump	Yes/No	No	
Dehumidifier zone 3	Manual activation of the dehumidifier in neutral air on zone 3.	Yes/No	No	
Zone 3 air conditioning	Manual activation of the air conditioner in cooled air in zone 3	Yes/No	No	
Hot/Cold three-way	Manual activation of the summer/winter three-way valve (M52)	Yes/No	No	

(*) If you are within the "Manual drives" menu, the 4-minute time-out for exiting the "Support" menu is not taken into account.



Menu/Support/Special parameters

Menu item	Description	Range	Default	Customised value
Dehumid. in cool.air	Dehumidification control in cooled air	Zone 1 / Zone 2	Zone 2	
Safety therm. Zone 2	Zone 2 safety thermostat	20÷80	45	
Safety therm. Zone 3	Zone 3 safety thermostat	20÷80	45	
Enable recirculation	DHW recirculation enabling	On / Off	Off	
Integr. multiplier	Not used	1÷100	10	
Enab.ext. CH resistance (*)	Enable external central heating integrated electrical resistance	Yes / No	No	
Enab. Expansion	Enabling of expansion kit for managing optional functions	Yes / No	No	
Enab. Heat./cool.select.	Enabling of central heating/cooling selector by means of external contact connected directly to the control panel (Fig. 16)	Yes / No	No	
Parameter 1	Enable flow probe Zone 1 (0 = disabled, 1 = enabled)	-1000÷1000	0	
Parameter 2	System-side electrical integration power (value multiplied by a factor of 10, e.g. 30 corresponds to a 3kW resistance)	-1000÷1000	30	
Parameter 3	Room antifreeze protection setpoint (value multiplied by a factor of 10, 40 is equal to 4°C)	-1000÷1000	50	
Parameter 4	Boost dehumidification (0 = disabled, 1 = enabled)	-1000÷1000	0	
Parameter 5	Temperature threshold below which the DHW integration to the heat pump is activated (value multiplied by a factor of 10, e.g. -200 corresponds to -20°C)	-1000÷1000	-200	
Parameter 6	Do not use	-1000÷1000	0	
Parameter 7	Do not use	-1000÷1000	0	
Parameter 8	Do not use	-1000÷1000	0	
Parameter 9	Do not use	-1000÷1000	0	
Parameter 10	Do not use	-1000÷1000	0	

(*) It is not possible to activate the recirculation function when using the external probe IU (optional).

INSTALLER

USER

MAINTENANCE/TECHNICIAN

TECHNICAL DATA



3.10 FIRST IGNITION PARAMETER SETTING

During the first activation of the appliance, it is necessary to customise the following parameters, which concern the generator operation, the type of Outdoor Unit and the type of system connected to the appliance.

In the menu

Support / Heat pump / HP Type

you must ensure that the model set is "MHP Mini".

If the function "Factory setting" is activated in the "General settings" menu, the parameter "HP Type = MHP Mini" must always be set.

In the menu

Support / Heat pump / Powers

it is necessary to set "HP Model", which corresponds to the power of the outdoor unit.

In the menu

Support / Heat pump / Timers

You can customise the device's restart delay by modifying the parameter "Anti-cycle time" and, in the presence of delayed opening systems, you can modify the parameter "Req.delay time TA".

In the menu

Support / Heat pump / Pump

it is possible to modify the heat pump circulator speed by modifying the parameter "Max pump speed".

It is necessary to adjust the pump speed according to the appliance power, to improve the operating efficiency of the machine.

The heat pump is equipped with a sanitary electric resistance as standard.

The standard supplied electrical resistance is disabled as a precaution (it is necessary for the resistance to be activated only in the presence of Domestic hot water / D.H.W. in the storage tank).

Therefore, it is necessary to enable the electrical resistance by modifying the following parameters.

Integration / Enable DHW integr.

it is decided whether to activate only the heat pump or only the resistance or both to perform the DHW Mode.

Modifying the parameter

Integration / DHW integration mode.

it is decided whether to activate the heat pump and the resistance in an alternate or simultaneous manner.

Modifying the parameter

Integration / DHW wait time

it is decided how long to activate the heat pump and the electrical resistance or both together.

When the outdoor temperature is lower than:

Special parameters / Parameter 5

the DHW electrical resistance activates automatically.



The first served operating mode, in case of contemporaneity, is decided with the parameter:

Configuration / Priority

The DHW Mode can have a maximum duration, settable with the parameter

Configuration / Max time DHW

beyond which the alarm is signalled.

The heat pump can manage up to 3 distribution pumps.

To activate the correct number of distribution pumps, modify the parameter:

System definition / Number of zones

It is possible to customise the operation of each individual zone.

Each zone can be enabled for a single operating mode, modifying the parameter

Configuration / Enablings / Mode

The system request for each zone can be made from a room thermostat, which must be enabled in the menu

Configuration / Enablings / Enable room thermostat

In case a remote device is used to control the requests, it is necessary to modify the parameter

Configuration / Enablings / Enable remote contr.

If a dehumidifier is present, it is necessary to modify the parameter

Configuration / Enablings / Enable dehumidifiers

and enable it by modifying the parameter

System definition / Multifunction relay 1 o Multifunction relay 2 o Multifunction relay 3 = valore da 1 a 4

depending on the type of function and zone where the dehumidifier is enabled.

It may happen that the dehumidifier has problems with receiving a very high supply temperature. For this reason, dehumidifier ignition can be prevented until the flow water drops below the desired level.

We suggest installing the dehumidifier only in mixed zones.

If more than one zone is enabled and the dehumidifier is installed on a direct zone, the NTC 10K B3435 flow probe must be installed in that zone.

Configuration / Enablings / Max dehum. temp.

Furthermore, if the setpoint calculated for the dehumidification is too high to carry out a request, the alarm is signalled and the dehumidifier is stopped. This value can be edited through the parameter:

Configuration / Enablings / Dehum. alarm set

In case a humidistat is used to control the dehumidification requests, it is necessary to modify the parameter

Configuration / Enablings / Enable humidistat

In the presence of a floor system, it is necessary to avoid the formation of condensate in the floor by enabling the use of the dew temperature calculation, provided a zone remote panel or a temperature/humidity probe has been installed:

Configuration / Enablings / Enable dew point

It is possible to enable the flow temperature control via the thermoregulation with external probe, by modifying the parameter

Configuration / Enablings / Ext. probe modul.

To improve system efficiency in certain types of installations, provided a zone remote panel or a temperature/humidity probe has been installed, it is possible to enable flow temperature control by modulation with a room probe, by modifying the parameter

Configuration / Enablings / Room. probe modul.

The system flow temperature drops (it rises in case of cooling) when the room temperature approaches the room setpoint. Modulation with room probe can only be enabled in the presence of a zone remote device.



3.11 DHW (DOMESTIC HOT WATER) BOOST

In order to activate the DHW (Domestic hot water) BOOST function, it is necessary to enable the DHW (Domestic hot water) electrical resistance by changing the parameter:

Integration / Enable DHW integr.

3.12 ANTI-LEGIONELLA

The indoor unit is equipped with a function to perform a thermal shock on the storage tank.

This function brings the appliance temperature to the maximum allowed with DHW integrative resistance enabled.

The function is enabled via the menu

DHW / Anti-legionella

The function is activated at the time set via the menu

Anti-legionella / Anti-legion.cycle time

on the week day set on the menu

Anti-legionella / Anti-legion.cycle day

it is possible to activate the all day function through the "Anti-legionella" menu.

The maximum allowed duration of the function corresponds to the value set in the parameter:

Anti-legionella / Max antilegion. time

if the function is not completed within the maximum allowed time, an alarm will be triggered.



It is possible to activate the function only with DHW el. resistance and eventually a thermostatic valve must be installed at the DHW outlet to prevent burns.

3.13 DHW (DOMESTIC HOT WATER) RECIRCULATION

The DHW recirculation function provides the greatest possible comfort in domestic hot water supply by constantly circulating the water.

To enable the DHW recirculation function, it is necessary to:

- install the recirculation probe, included in the optional kit, and enable it by adjusting the parameter:

Special parameters / Enable recirculation

- install the recirculation circulator, included in the optional kit, by connecting it to the terminals of the two relays kit, and enable it by adjusting the parameter:

System definition / Multifunction relay 1 o Multifunction relay 2 o Multifunction relay 3 = 7

Once installed, the probe makes it possible to improve the efficiency of the system by switching off the circulator in the event that the DHW temperature reaches the set DHW temperature.

The operation of the circulator can be further reduced by setting the time slots as desired in the menu:

Menu / Clock and programs / Recirculation Program



3.14 PUMP ANTI-BLOCK

The indoor unit has a function that starts the pump at least once every 24 hours for the duration of 30 seconds in order to reduce the risk of the pump becoming blocked due to prolonged inactivity.

3.15 THREE-WAY ANTI-BLOCK

The indoor unit has a function that activates the motorised three-way unit 24 hours after the last time it operated by running a complete cycle in order to reduce the risk of the three-way blocking due to prolonged inactivity.

3.16 SYSTEM SETPOINT CORRECTION

In the presence of hydraulic disconnections on the system downstream of the appliance distribution circuit, it is possible to activate a function that makes it possible to correct the request setpoint to the generator to approach the set zone setpoint as much as possible. The corrections can be made either in central heating or in cooling mode and, if enabled, apply to all active zones.

To activate this FUNCTION, it is necessary to:

- install, after hydraulic disconnection, the zone 1 B3-1 flow probe (optional) connected to the control panel terminal board as shown in figure 16.
- Enable zone probe 1 with the "Parameter 1" in Menu / Support / Special parameters".

Then set the parameters

System definition / Max CH adjust

System definition / Max Cool. adjust

with a value $> 0^{\circ}\text{C}$.

Following a demand, the correction begins after a time equal to

System definition / Activation time

and continue by 1°C each

System definition / Increase time

minutes.



3.17 INTEGRATION WITH SYSTEM INTERNAL ELECTRICAL RESISTANCE

The heat pump is equipped with an internal system electric resistance as per standard.

The electrical resistance supplied as per standard is disabled for precautionary reasons (the resistance must only be activated when there is water in the system and flow rate).

Modifying the parameter

Integration / Enable heat.integr.

it is decided whether to activate only the heat pump or only the resistance or both to perform the Central heating mode.

Modifying the parameter

Integration / CH integration mode

it is decided whether to activate the heat pump and the resistance in an alternate or simultaneous manner.

Modifying the parameter

Integration / CH wait time

you decide the time after which the electrical resistance is activated at the same time as the heat pump if the set flow setpoint is not reached.



With alternative integration mode, the wait time does not affect the functioning algorithm.

In normal operation, the integration resistance is only activated when the outdoor temperature is below the parameter

Integration / Min. CH integr.temp.:

- with alternative mode, only the resistance is activated;
- with simultaneous mode, the resistance and heat pump are activated simultaneously after the heating wait time.

The first served operating mode, in case of contemporaneity, is decided with the parameter:

Configuration / Priority



3.18 INTEGRATION WITH SYSTEM EXTERNAL ELECTRICAL RESISTANCES

External electrical resistances can operate in addition to the internal resistance.

They are activated with the same logic as the internal resistance.

For the electrical connection see the reference wiring diagram (Fig. 15).

If one or more external electric resistances are installed in combination with one of the two-zone kits (supplied by Immergas), integration must be installed between the UI MHPMEH indoor unit and the distribution kit.

If one or more external electric resistances are installed, in addition to the parameters described in paragraph 3.17 the following parameters must also be adjusted:

Special parameters / Enab.ext. CH resistance

selecting option Yes

Special parameters / Parameter 2

by entering the total installed power value (multiplied by a factor of 10).

3.19 ZONE 2/3 SAFETY THERMOSTAT

In case of zone 2 or zone 3 installation, a control on the zone flow temperature is enabled which prevents the distribution of water above a certain temperature.

It is possible to modify these limits through the parameters

Special parameters / Safety therm. Zone 2

Special parameters / Safety therm. Zone 3

3.20 CONJUNCTION MODE

In case of simultaneous DHW (Domestic hot water) and system request, the system decides which to service to perform on the basis of an alternating logic determined by the system.

It is possible to modify this logic, so that the system simultaneously deals with both services, using the generators available.

Operation in this mode can be activated by editing the following parameters:

System definition / Concomitant mode

Moreover, also the DHW electrical resistance needs to be enabled:

Integration / Enable DHW integr.

INSTALLER

USER

MAINTENANCE TECHNICIAN

TECHNICAL DATA



3.21 HEAT PUMP DISABLING FUNCTION

No request will be met, excluding the safety functions.
To enable this function, please edit the following parameters:

Heat pump / Powers / HP power off = Yes

User / Disable HP = Yes

One can then choose whether to activate the disabling according to a schedule by setting time slots in the menu:

User / Start hourly HP disab.

User / End hourly HP disab.

or via an external contact that can be connected to the expansion kit.

3.22 POWER REDUCTION FUNCTION

To enable this function, please edit the following parameters:

User / Disable HP = Yes

Heat pump / Powers / HP power off = Reduct.

One can then choose whether to activate the reduction according to a schedule by setting time slots in the menu:

User / Start hourly HP disab.

User / End hourly HP disab.

or via an external contact that can be connected to the expansion kit.

3.23 DIVERTER VALVE MANAGEMENT (SUMMER / WINTER)



Valid only in combination with the Two Multifunction Relay Kit.

The two multi-function relay kit allows the potential-free contact of the outlet to be used to control a 3-way summer/winter valve. Contact closure occurs in SUMMER mode.

To enable this function, it is necessary to adjust the parameter:

System definition / Multifunction relay 1 o Multifunction relay 2 o Multifunction relay 3 = 5

3.24 DIVERTER VALVE MANAGEMENT (DHW/SYSTEM) (OPTIONAL)

The two multi-function relay kit allows the potential-free contact of the outlet to be used to control a 3-way DHW/system valve. Contact closure occurs in SYSTEM mode.

To enable this function, it is necessary to adjust the parameter:

System definition / Multifunction relay 1 o Multifunction relay 2 o Multifunction relay 3 = 6

3.25 HEAT PUMP CIRCULATOR FUNCTION

The operating mode of the heat pump circulator can be defined via the parameter:

Menu / Support / Heat pump / Pump

When set to **Max Sp.** the pump will always run at the speed defined by the parameter **Max pump speed**; when set to **Modul.** the pump will run at a variable speed between the values defined by the parameters **Max pump speed** and **Min pump speed** with control logics aimed at minimising consumption and guaranteeing the temperature delta between flow and return defined by the parameter **Pump T Delta** and corresponding to fixed 5°C.



3.26 EXTERNAL PROBE SETTING

To activate the optional external probe, it is necessary to modify the parameter:

System definition / External probe = UI

If the temperature probe is particular far from the indoor unit, it is possible to correct its value by modifying

System definition / External probe corr.



It is not possible to use the optional external probe kit in the case of DHW recirculation enabling. The temperature read by the optional external probe is only useful to calculate the system setpoint with temperature control active or when managing generators with bivalent temperature. The operating limit external temperature of the outdoor unit is only the one installed on the same unit.

3.27 MANUAL DRIVES

In the menu

Support / Manual drives

it is possible to manage all the main appliance loads in manual mode.

These parameters must be used in case of system troubleshooting.

To correctly activate the functions, it is necessary to set the system in “stand-by”.

3.28 OUTDOOR UNIT TEST MODE FUNCTION

When using the outdoor unit's test mode (see outdoor unit instruction manual), the indoor unit must be set to an operating mode other than 'Stand-by'.

The alarm 183 is triggered during the test, meaning “Test mode” in progress.

3.29 OUTDOOR UNIT PUMP DOWN

If the pump down function is used (see outdoor unit instruction booklet) the indoor unit must be set in “Stand-by”.

The function can only be activated if the appliance is not under alarm.

3.30 SUPERVISION DEVICE CONFIGURATION

The appliance can be configured so that it can be controlled by the external supervision devices such as Dominus or other types of home automation systems (not supplied by Immergas).

For the configuration, it is necessary to modify the parameter

System definition / System supervision



It is not possible to configure both devices simultaneously.

3.31 PHOTOVOLTAIC FUNCTION

It is possible to configure the appliance so that the energy produced by a photovoltaic system is used to store it in the DHW storage tank by increasing the set point to 55°C.

The activation of the Photovoltaic function is generated by the closing of contacts 61-62 (potential-free contact) from the photovoltaic inverter, it does not change the management of the generators and is signalled by a specific symbol on the control panel.

For the configuration, it is necessary to modify the parameter:

System definition / Photovoltaic function



3.32 ACCESS TO CONTROL PANEL AND ELECTRICAL PANEL

Follow the instructions below to gain access to the control panel and main electrical panel:

- Remove the plastic protection caps (2) and loosen the screws (3) to remove the aesthetic profile (1).
- Open the cover door (4) to make it tilt.
- Remove the rubber protection caps (5), loosen the two upper front screws and the lower screws (6) to remove the cover (4)

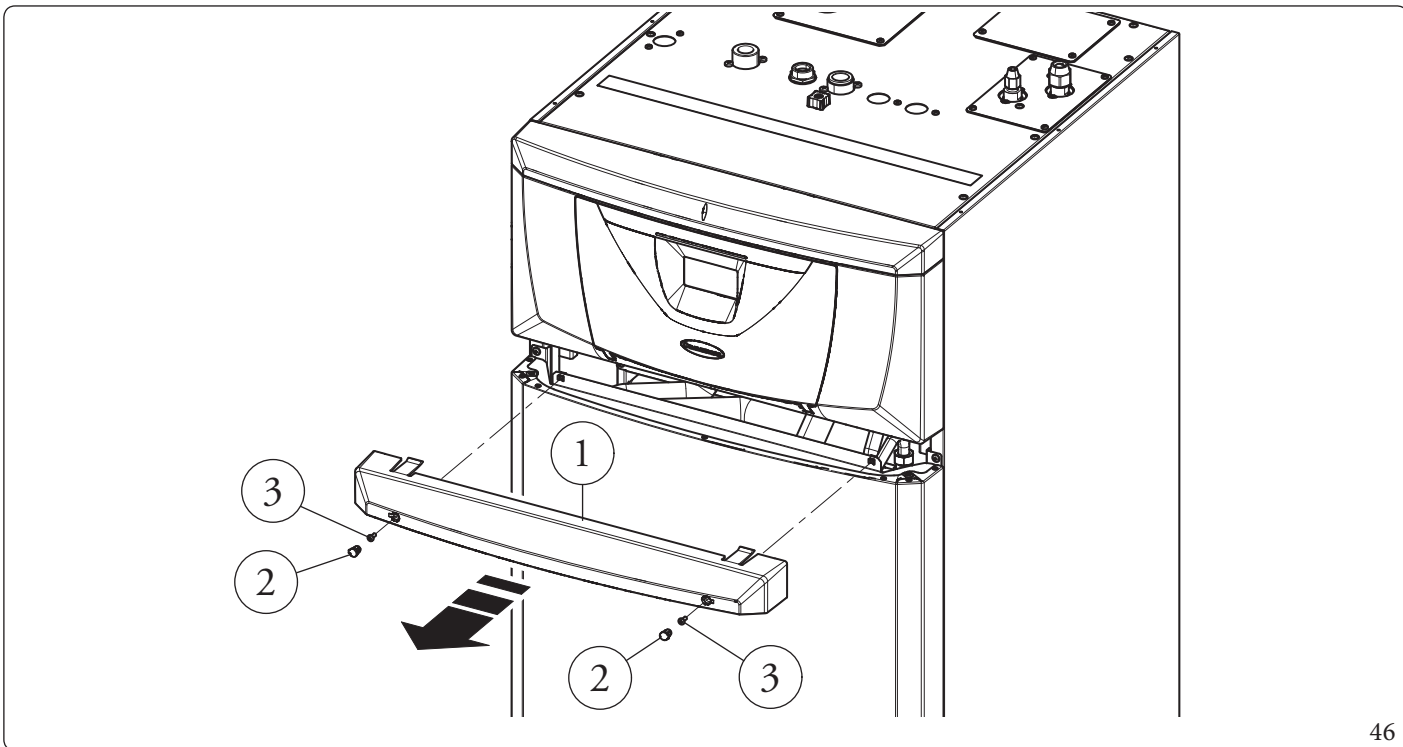

46

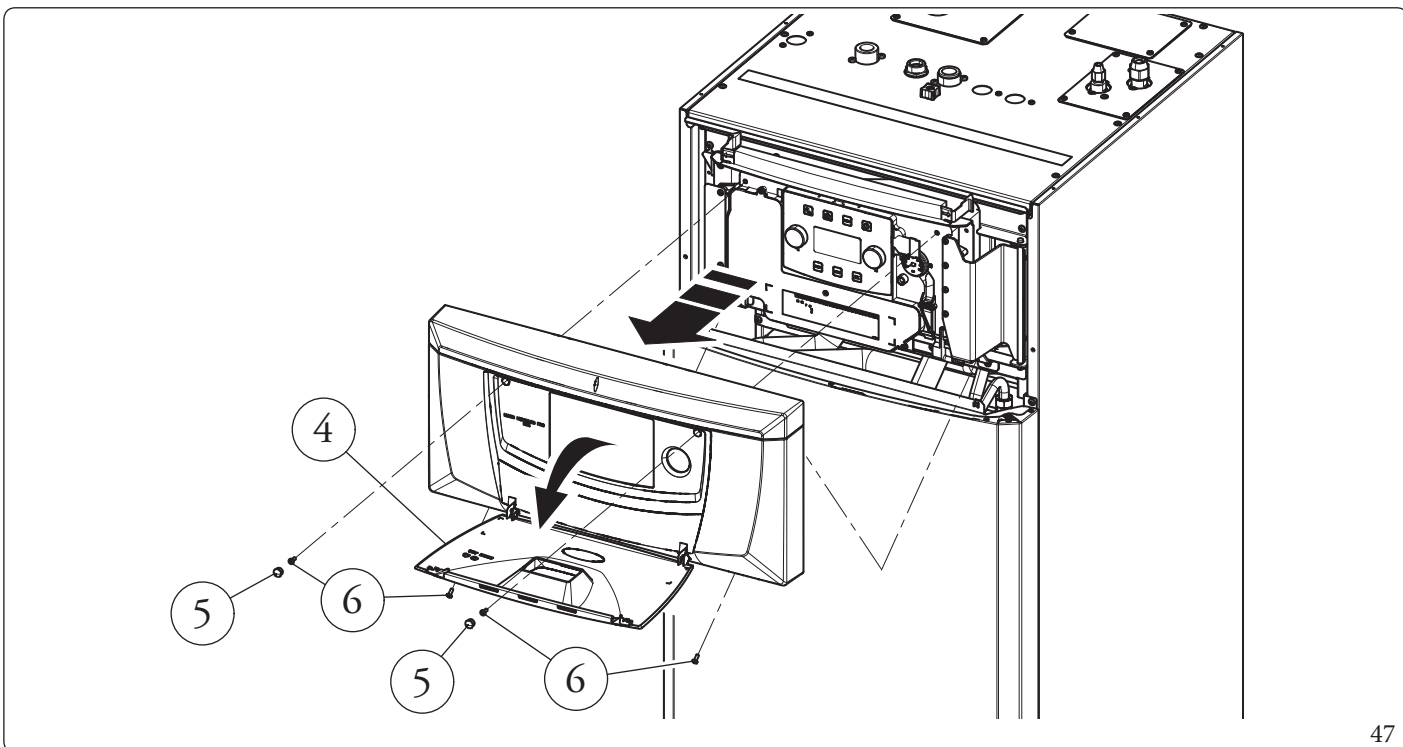

47

- Unscrew the 3 fixing screws (7) on the control panel.
- After which, pull the control panel (8) towards you and turn it as shown in the figure 49.

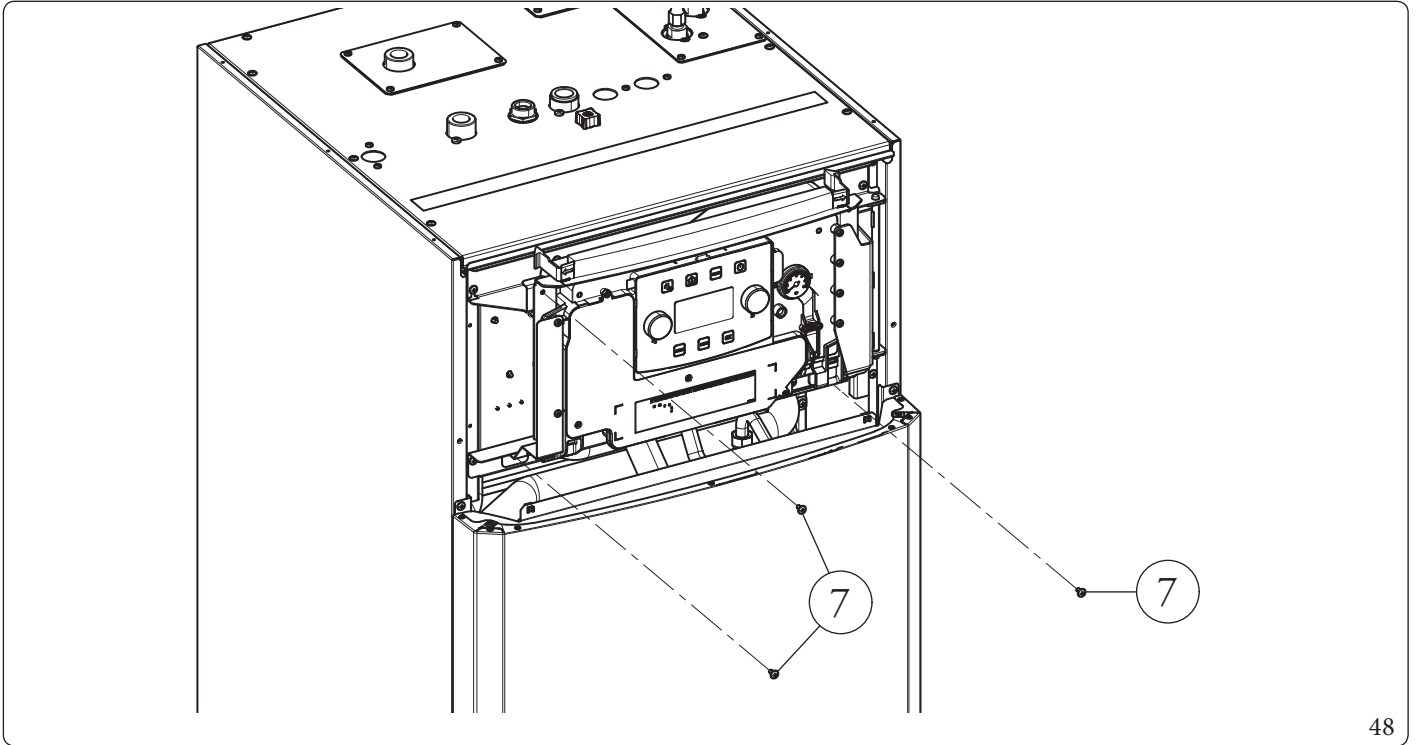

48

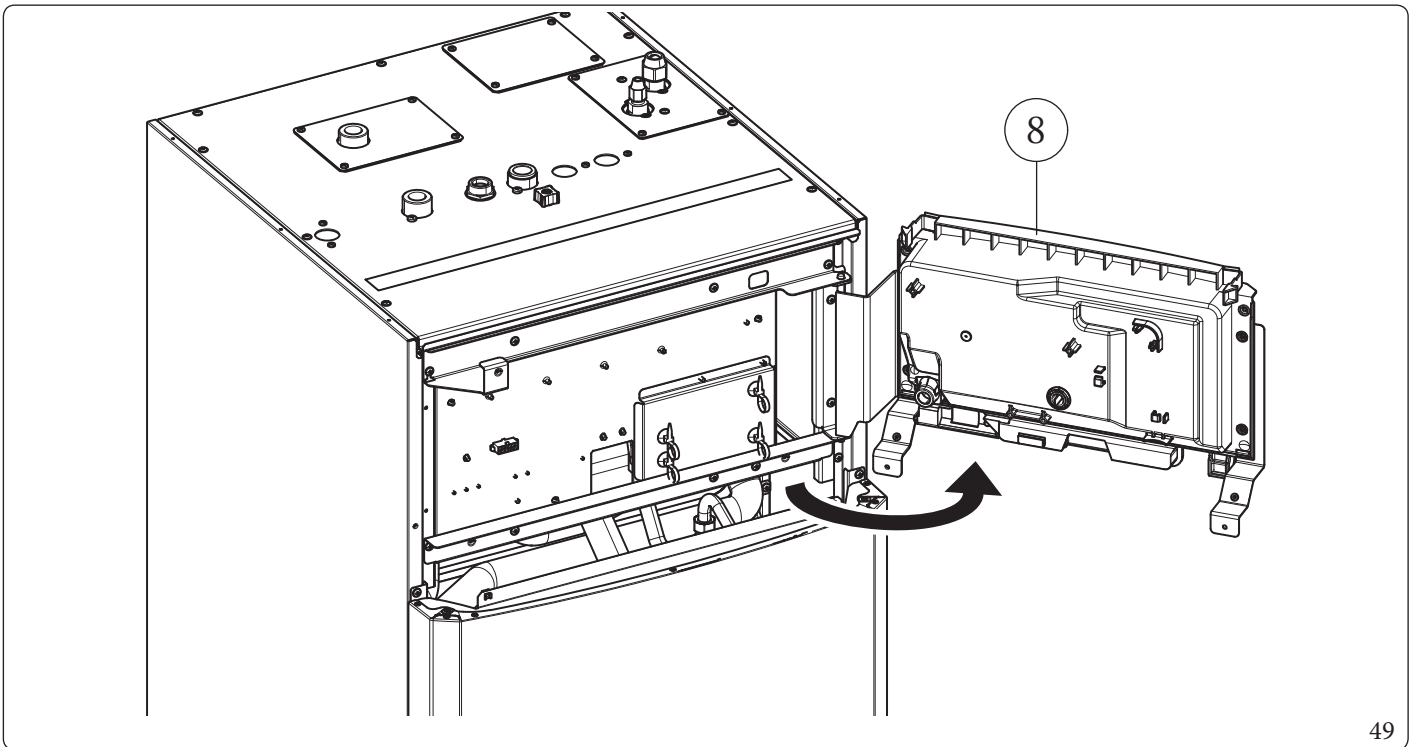

49

INSTALLER

USER

MAINTENANCE/TECHNICIAN

TECHNICAL DATA



- Unscrew the 4 screws (9).
- Open the main panel (10) as shown in figure 51.

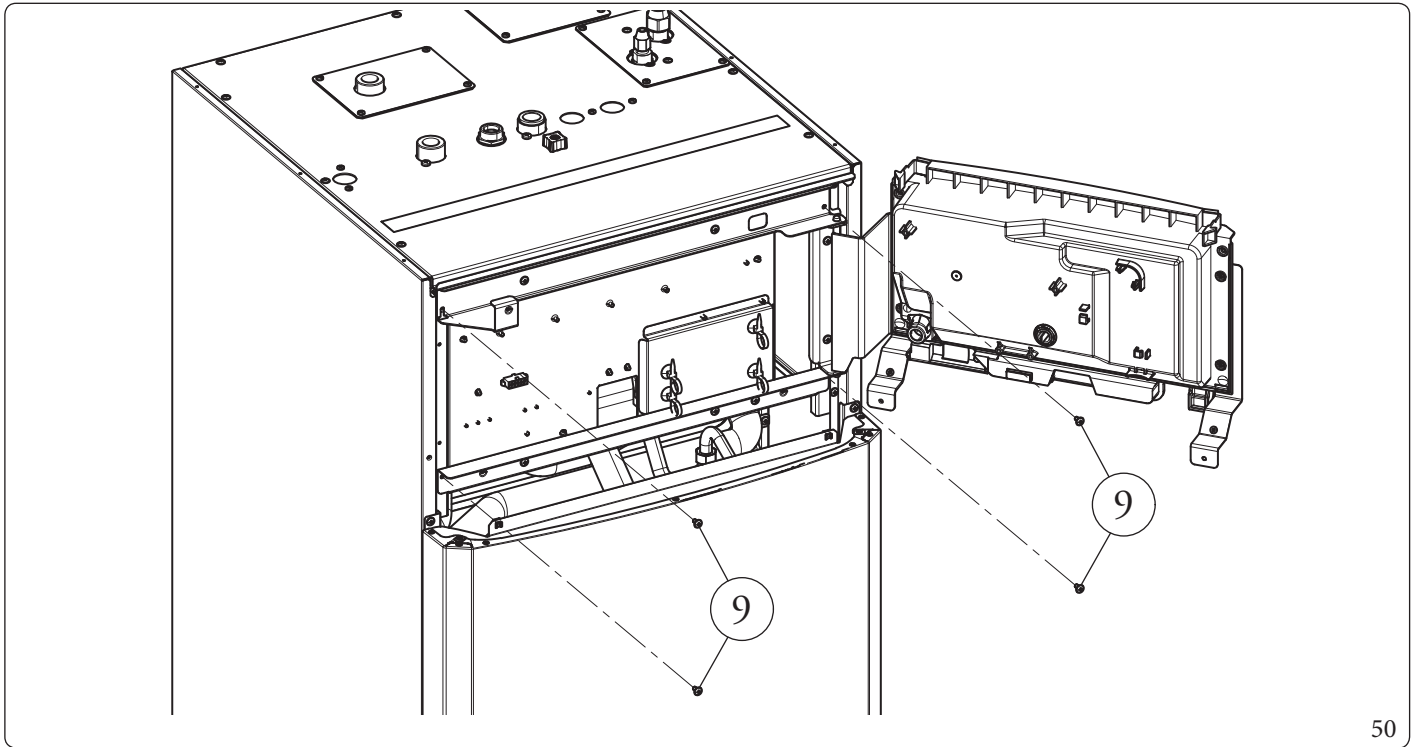

50

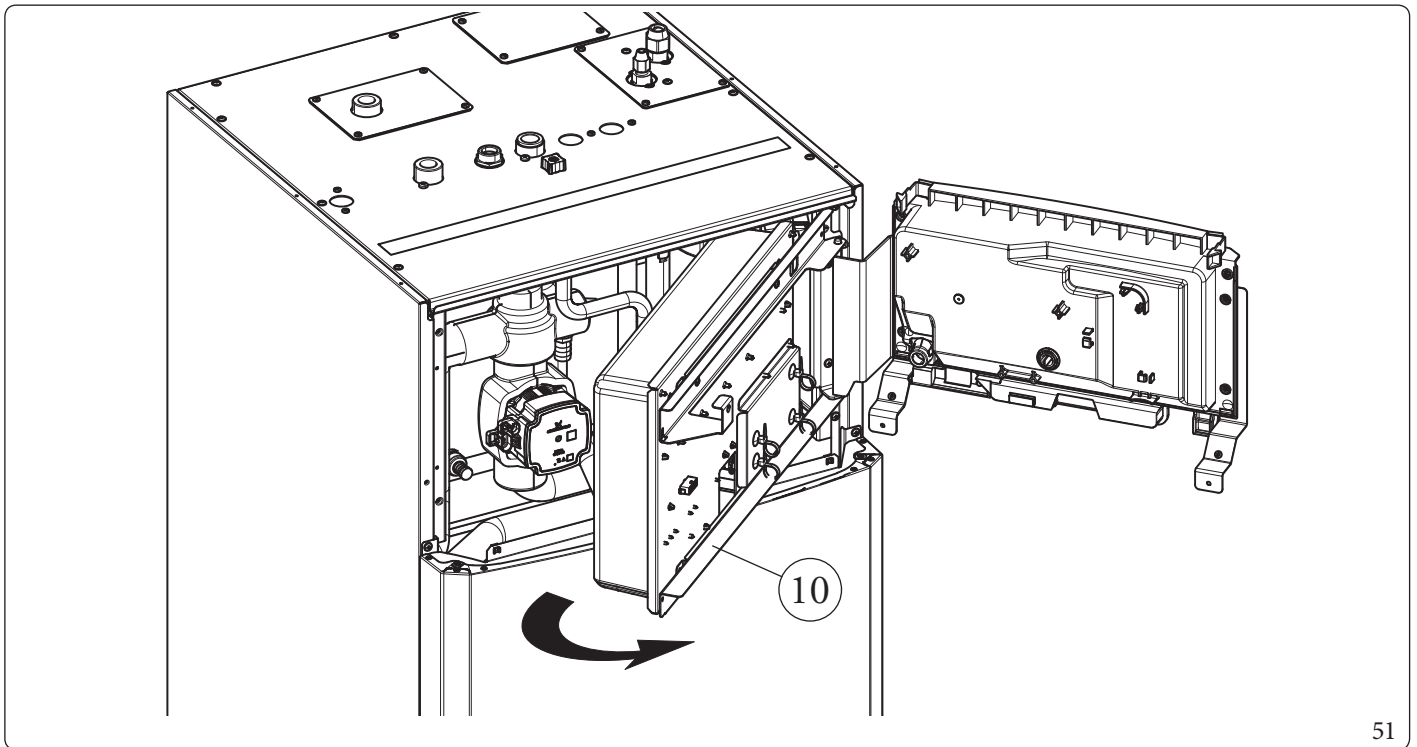

51

3.33 CASINGREMOVAL

To facilitate indoor unit maintenance the casing can be completely removed as follows:

Aesthetic profile (1) (Fig. 46).

- Remove the plastic protection caps (2) and loosen the screws (3) to remove the aesthetic profile (1).

Cover disassembly (4) (Fig. 47).

- Open the cover door (4) to make it tilt.
- Remove the rubber protection caps (5), loosen the two upper front screws and the lower screws (6) to remove the cover (4)

Disassembling the front casing (7) (Fig. 52)

- Disassemble the front casing (7) by loosening the two screws (8) and pushing it upwards in order to free it from the fixing slots and pulling it towards you (Det. A).

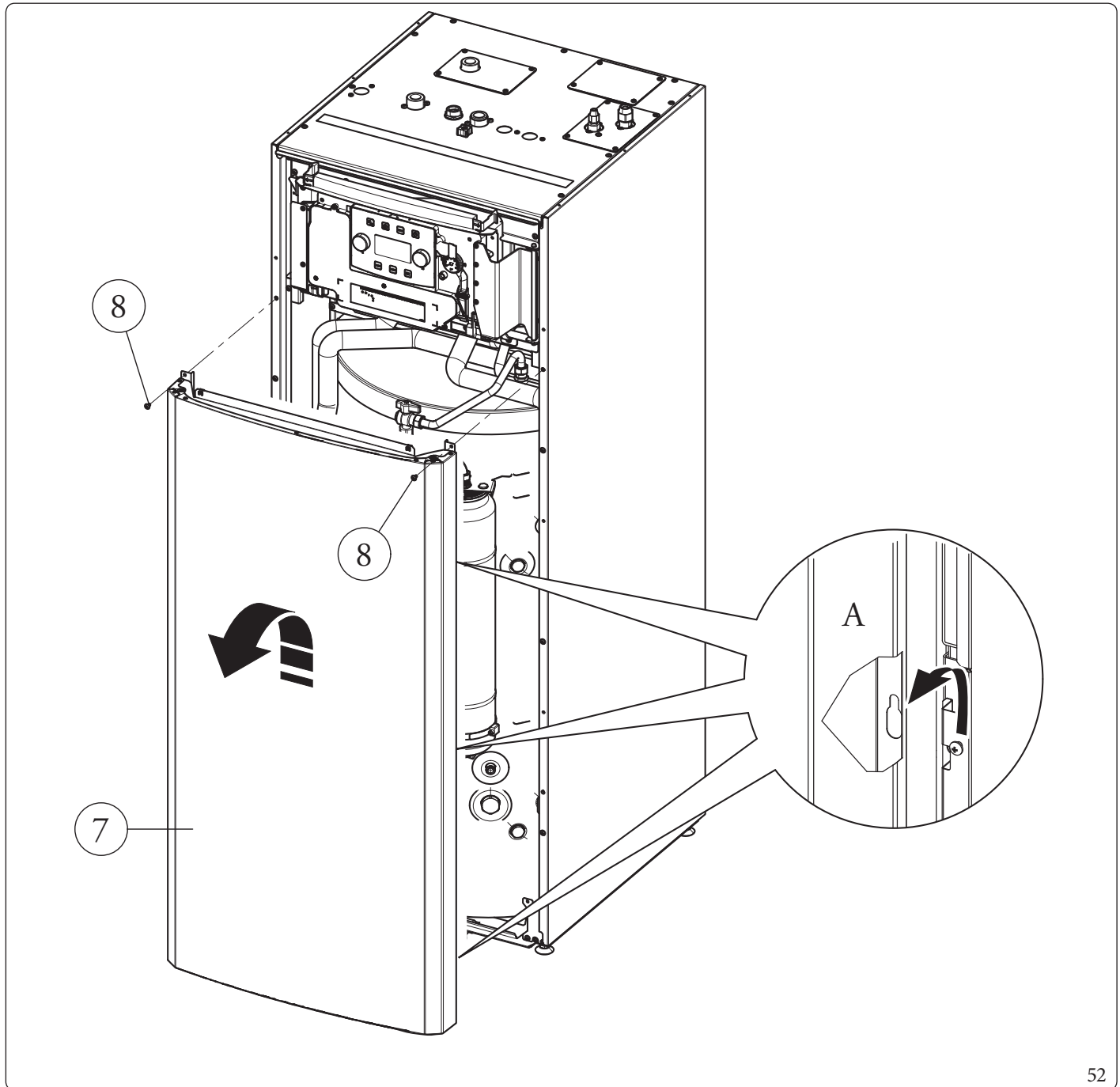

INSTALLER

USER

MAINTENANCE TECHNICIAN

TECHNICAL DATA

52



Disassembly of casing sides (9 and 10) (Fig. 53)

- Remove the left and right sides (9 and 10) by unscrewing the screws (11 and 12) present; then push slightly upwards to release the sides from their seats and pull upwards (Det. A).

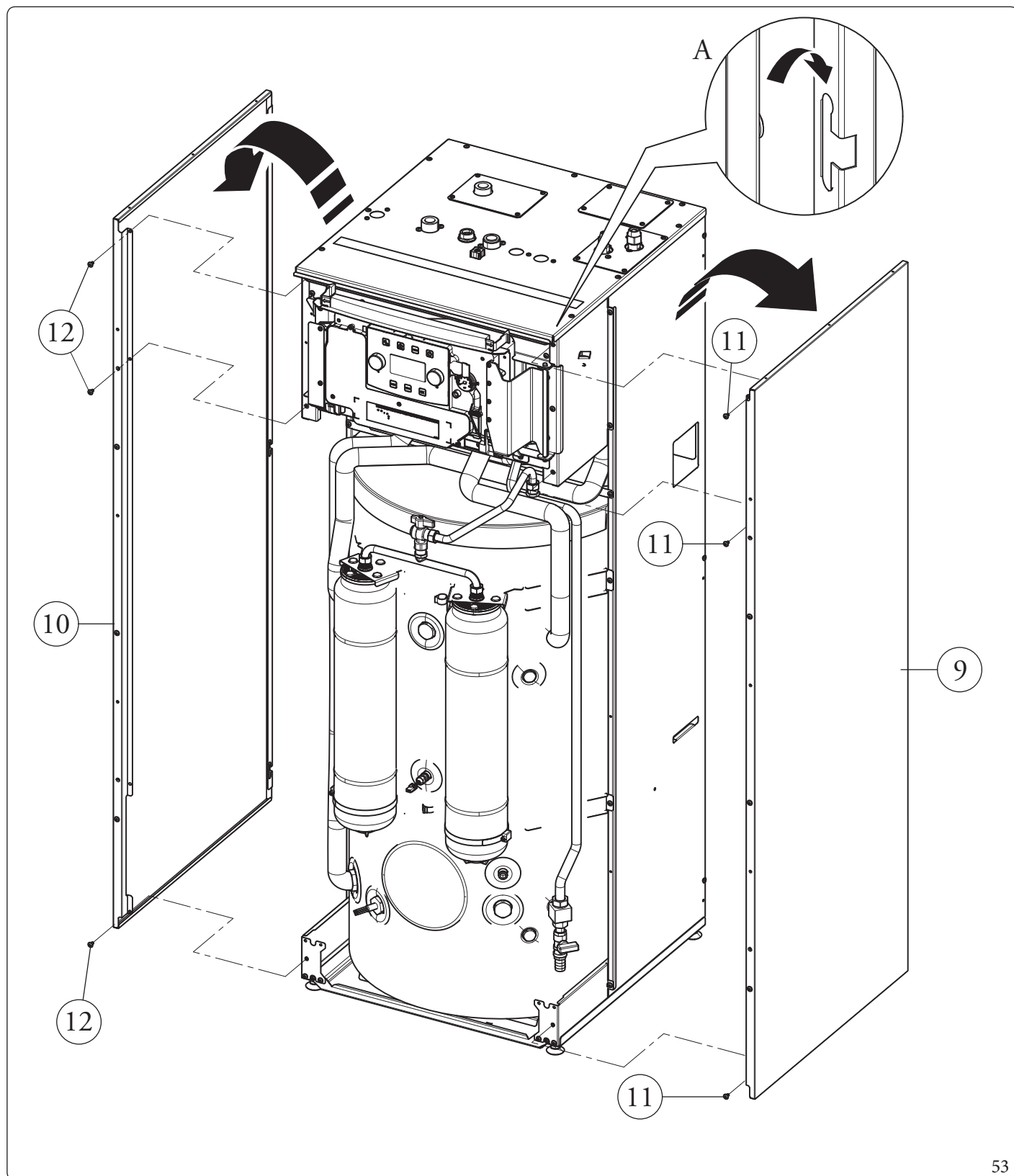

4 TECHNICAL DATA

4.1 TECHNICAL DATA TABLE

The following data refers to product data.

		MAGISHERCULES PROMINI6EH	MAGISHERCULES PROMINI9EH
Nominal data for low temperature applications (A7/W35)*			
Nominal central heating output	kW	6,00	9,00
Absorption	kW	1,22	1,87
COP	kW/kW	4,92	4,81
Nominal data for low temperature applications (A35/W18)*			
Nominal cooling output	kW	6,50	8,70
Absorption	kW	1,47	2,11
EER	kW/kW	4,42	4,12
Nominal data for intermediate temperature applications (A7/W45)**			
Nominal central heating output	kW	5,40	8,60
Absorption	kW	1,51	2,33
COP	kW/kW	3,58	3,69
Nominal data for intermediate temperature applications (A35/W7)**			
Nominal cooling output	kW	4,70	6,50
Absorption	kW	1,44	1,95
EER	kW/kW	3,26	3,33
Nominal data for medium temperature applications (A7/W55)***			
Nominal central heating output	kW	4,80	8,00
Absorption	kW	1,81	2,73
COP	kW/kW	2,65	2,93

* Central heating mode status: heat exchanger water inlet/remains at 30 °C/35 °C, outdoor air temperature 7 °C db/6 °C wb. Performance in compliance with EN 14511.

Cooling mode status: heat exchanger water inlet/remains at 23 °C/18 °C, outdoor air temperature 35 °C. Performance in compliance with EN 14511.

* Central heating mode status: heat exchanger water inlet/remains at 40 °C/45 °C, outdoor air temperature 7 °C db/6 °C wb.

Cooling mode status: heat exchanger water inlet/remains at 12 °C/7 °C, outdoor air temperature 35 °C. Performance in compliance with EN 14511.

*** Central heating mode status: inlet/remains at 47 °C/55 °C, outdoor air temperature 7 °C db/6 °C wb. Performance in compliance with EN 14511.

INSTALLER

USER

MAINTENANCE TECHNICIAN

TECHNICAL DATA



Indoor Unit data

		UIMHPM6EH	UIMHPM9EH
Dimensions (Width x Height x Depth)	mm	600x1600x675	
Water content	l	26,2	
System expansion vessel volume	l	10	
System expansion vessel pre-charged pressure	bar	1	
Hydraulic circuit max. operating pressure	kPa	300	
Domestic hot water circuit min. dynamic pressure	kPa	30	
Domestic hot water circuit pressure	kPa	800	
DHW (Domestic hot water) expansion vessel volume	l	12	
DHW expansion vessel pre-charged pressure	bar	4	
Storage tank water content	l	171	
Electrical connection	V/Hz	Single-phase, 230Vac, 50Hz	
Absorption without additional loads	W	95	
Domestic hot water integrated resistance absorption	W	2250	
Internal system integrative resistance absorption	W	3000	
EEI value	-	≤0,20 - Part. 3	
Equipment electrical system protection	-	IPX5D	
Ambient temperature range of indoor unit in summer mode	°C	+10...+40	
Ambient temperature range of indoor unit in winter mode	°C	0...+35	
Empty indoor unit weight	kg	150	
Full indoor unit weight	kg	356	

Product data

		MAGISHERCULES PRO MINI 6EH	MAGISHERCULES PRO MINI 9EH
Maximum heating temperature	°C	65	
Adjustable central heating temperature (max operating field)	°C	20-65	
Cooling adjustable temperature (max. operating field)	°C	5-25	
Minimum circulation flow rate	l/h	500	
Head available with 1000l/h flow rate	kPa	82	
Head available with 2000l/h flow rate	kPa	40	
Domestic hot water adjustable temperature	°C	10-55	
Domestic hot water adjustable temperature with DHW integration resistance	°C	10-65	
Room temperature in cooling mode	°C	+10...+46	
Room temperature in central heating mode	°C	-25...+35	
Domestic hot water room temperature	°C	-25...+35	
Domestic hot water room temperature with DHW integration resistance	°C	-25...+46	

4.2 MAGIS HERCULES PRO MINI 6 EH PRODUCT FICHE (IN COMPLIANCE WITH REGULATION 811/2013)

A	Supplier's name or trademark		-	Immergas S.p.A
B	Supplier's model identifier		-	MAGIS HERCULES PRO MINI 6 EH
C	For space heating	Application temperature	-	Average temperature
	For water heating	Stated load profile	-	L
D	Seasonal energy efficiency class of room heating	Average temperature	-	A++
		Low temperature	-	A+++
	Energy efficiency class of water heating		-	A+
E	Nominal heat output (average climate condition)	Average temperature	kW	6
		Low temperature	kW	6
F	Annual energy consumption for room heating (average climate condition)	Average temperature	kWh	3775
		Low temperature	kWh	2739
	Annual energy consumption for water heating (average climate condition)		kWh	884
G	Seasonal energy efficiency of room heating (average climate condition)	Average temperature	%	128
		Low temperature	%	178
	Energy efficiency of water heating (average climate condition)		%	116
H	Lwa sound power level indoors		dB	39
I	Operation only during dead hours		-	No
J	Specific precautions		-	-
K	Nominal heat output (colder climate condition)	Average temperature	kW	5
		Low temperature	kW	5
	Nominal heat output (warmer climate condition)	Average temperature	kW	6
		Low temperature	kW	6
L	Annual energy consumption for room heating (colder climate condition)	Average temperature	kWh	4863
		Low temperature	kWh	3313
	Annual energy consumption for room heating (warmer climate condition)	Average temperature	kWh	1945
		Low temperature	kWh	1256
	Annual energy consumption for water heating (colder climate condition)		kWh	-
Annual energy consumption for water heating (warmer climate condition)		kWh	759	
M	Seasonal energy efficiency of room heating (colder climate condition)	Average temperature	%	94
		Low temperature	%	140
	Seasonal energy efficiency of room heating (warmer climate condition)	Average temperature	%	151
		Low temperature	%	235
N	Lwa sound power level outdoors		dB	60

INSTALLER

USER

MAINTENANCE TECHNICIAN

TECHNICAL DATA



4.3 TABLE 2 REGULATION 813/2013

Model		MAGISHERCULES PRO MINI 6EH					
Air/water heat pump	YES	Low temperature heat pump				NO	
Water/water heat pump	NO	With Supplementary heater				NO	
Brine/water heat pump	NO	Mixed central heating device with heat pump:				YES	
The parameters are declared for average temperature application, except for low temperature heat pumps. The parameters for low temperature heat pumps are declared for low temperature application							
The parameters are declared for average climatic conditions							
Element	Symbol	Value	Unit	Element	Symbol	Value	Unit
Nominal heat output	$P_{nomi-nale}$	6	kW	Room central heating seasonal energy efficiency	η_s	128	%
Central heating capacity declared with a partial load and indoor temperature equivalent to 20°C and outdoor temperature T_j				Performance coefficient declared with indoor temperature equivalent to 20°C and outdoor temperature T_j			
$T_j = -7\text{ °C}$	P_{dh}	5,3	kW	$T_j = -7\text{ °C}$	COP_d	2,00	-
$T_j = +2\text{ °C}$	P_{dh}	3,2	kW	$T_j = +2\text{ °C}$	COP_d	3,23	-
$T_j = +7\text{ °C}$	P_{dh}	2,1	kW	$T_j = +7\text{ °C}$	COP_d	4,47	-
$T_j = +12\text{ °C}$	P_{dh}	1,9	kW	$T_j = +12\text{ °C}$	COP_d	5,72	-
$T_j = \text{bivalent temperature}$	P_{dh}	5,3	kW	$T_j = \text{bivalent temperature}$	COP_d	2,00	-
$T_j = \text{operating limit temperature}$	P_{dh}	5,0	kW	$T_j = \text{operating limit temperature}$	COP_d	1,80	-
for air/water heat pumps: $T_j = -15\text{ °C}$ (se TOL < -20 °C)	P_{dh}	0,0	kW	for air/water heat pumps: $T_j = -15\text{ °C}$ (se TOL < -20 °C)	COP_d	0	-
Bivalent temperature	T_{biv}	-7	°C	For air/water heat pumps: Operating limit temperature	TOL	-10	°C
Central heating capacity cycle intervals	P_{cyc}	0,0	kW	Cycle intervals efficiency	COP_{cyc} or PER_{cyc}	0	-
Degradation coefficient	C_{dh}	0,9	-	Water heating temperature operating limit	WTOL	55	°C
Different mode of energy consumption from the active mode				Supplementary heater			
OFF mode	P_{OFF}	0,004	kW	Nominal heat output	P_{sup}	-	kW
Thermostat mode off	P_{TO}	0,012	kW	Type of energy supply voltage	power reduction		
Standby mode	P_{SB}	0,012	kW				
Guard heating mode	P_{CK}	0,000	kW				
Other items							
Capacity control	VARIABLE			For air/water heat pumps: nominal air output to outside	-	2580	m ³ /h
Indoor/outdoor sound level	L_{WA}	39/60	dB	For water or brine/water heat pumps: nominal flow of brine or water, outdoor heat exchanger	-	-	m ³ /h
Annual energy consumption	Q_{HE}	3775	kWh or GJ				
For mixed central heating appliances with a heat pump							
Stated load profile	L			Water central heating energy efficiency	η_{wh}	116	%
Daily electrical power consumption	Q_{elec}	4,18	kWh	Daily fuel consumption	Q_{fuel}	-	kWh
Annual energy consumption	AEC	884	kWh	Annual fuel consumption	AFC	-	GJ
Contact information	Immergas S.p.A. via Cisa Figure n.95						

INSTALLER

USER

MAINTENANCE TECHNICIAN

TECHNICAL DATA



4.4 MAGIS HERCULES PRO MINI 9 EH PRODUCT FICHE (IN COMPLIANCE WITH REGULATION 811/2013)

A	Supplier's name or trademark		-	Immergas S.p.A
B	Supplier's model identifier		-	MAGIS HERCULES PRO MINI 9 EH
C	For space heating	Application temperature	-	Average temperature
	For water heating	Stated load profile	-	XL
D	Seasonal energy efficiency class of room heating	Average temperature	-	A++
		Low temperature	-	A+++
	Energy efficiency class of water heating		-	A
E	Nominal heat output (average climate condition)	Average temperature	kW	8
		Low temperature	kW	8
F	Annual energy consumption for room heating (average climate condition)	Average temperature	kWh	5106
		Low temperature	kWh	3906
	Annual energy consumption for water heating (average climate condition)		kWh	1595
G	Seasonal energy efficiency of room heating (average climate condition)	Average temperature	%	126
		Low temperature	%	175
	Energy efficiency of water heating (average climate condition)		%	105
H	Lwa sound power level indoors		dB	38
I	Operation only during dead hours		-	No
J	Specific precautions		-	-
K	Nominal heat output (colder climate condition)	Average temperature	kW	7
		Low temperature	kW	8
	Nominal heat output (warmer climate condition)	Average temperature	kW	8
		Low temperature	kW	9
L	Annual energy consumption for room heating (colder climate condition)	Average temperature	kWh	7141
		Low temperature	kWh	5270
	Annual energy consumption for room heating (warmer climate condition)	Average temperature	kWh	2723
		Low temperature	kWh	1891
	Annual energy consumption for water heating (colder climate condition)		kWh	-
	Annual energy consumption for water heating (warmer climate condition)		kWh	1388
M	Seasonal energy efficiency of room heating (colder climate condition)	Average temperature	%	94
		Low temperature	%	137
	Seasonal energy efficiency of room heating (warmer climate condition)	Average temperature	%	154
		Low temperature	%	241
N	Lwa sound power level outdoors		dB	64

INSTALLER

USER

MAINTENANCE TECHNICIAN

TECHNICAL DATA



4.5 TABLE 2 REGULATION 813/2013

Model		MAGISHERCULES PRO MINI 9 EH					
Air/water heat pump	YES	Low temperature heat pump				NO	
Water/water heat pump	NO	With Supplementary heater				NO	
Brine/water heat pump	NO	Mixed central heating device with heat pump:				YES	
The parameters are declared for average temperature application, except for low temperature heat pumps. The parameters for low temperature heat pumps are declared for low temperature application							
The parameters are declared for average climatic conditions							
Element	Symbol	Value	Unit	Element	Symbol	Value	Unit
Nominal heat output	$P_{nomi-nale}$	8	kW	Room central heating seasonal energy efficiency	η_s	126	%
Central heating capacity declared with a partial load and indoor temperature equivalent to 20°C and outdoor temperature T_j				Performance coefficient declared with indoor temperature equivalent to 20°C and outdoor temperature T_j			
$T_j = -7\text{ °C}$	P_{dh}	7,1	kW	$T_j = -7\text{ °C}$	COP_d	1,76	-
$T_j = +2\text{ °C}$	P_{dh}	4,3	kW	$T_j = +2\text{ °C}$	COP_d	3,23	-
$T_j = +7\text{ °C}$	P_{dh}	2,8	kW	$T_j = +7\text{ °C}$	COP_d	4,62	-
$T_j = +12\text{ °C}$	P_{dh}	2,6	kW	$T_j = +12\text{ °C}$	COP_d	5,88	-
$T_j =$ bivalent temperature	P_{dh}	7,1	kW	$T_j =$ bivalent temperature	COP_d	1,76	-
$T_j =$ operating limit temperature	P_{dh}	4,9	kW	$T_j =$ operating limit temperature	COP_d	1,35	-
for air/water heat pumps: $T_j = -15\text{ °C}$ (se TOL < -20 °C)	P_{dh}	0,0	kW	for air/water heat pumps: $T_j = -15\text{ °C}$ (se TOL < -20 °C)	COP_d	0	-
Bivalent temperature	T_{biv}	-7	°C	For air/water heat pumps: Operating limit temperature	TOL	-10	°C
Central heating capacity cycle intervals	P_{cyc}	0,0	kW	Cycle intervals efficiency	COP_{cyc} o PER_{cyc}	0	-
Degradation coefficient	C_{dh}	0,9	-	Water heating temperature operating limit	WTOL	55	°C
Different mode of energy consumption from the active mode				Supplementary heater			
OFF mode	P_{OFF}	0,004	kW	Nominal heat output	P_{sup}	-	kW
Thermostat mode off	P_{TO}	0,012	kW	Type of energy supply voltage	power reduction		
Standby mode	P_{SB}	0,012	kW				
Guard heating mode	P_{CK}	0,000	kW				
Other items							
Capacity control	VARIABLE			For air/water heat pumps: nominal air output to outside	-	2580	m ³ /h
Indoor/outdoor sound level	L_{WA}	38/64	dB	For water or brine/water heat pumps: nominal flow of brine or water, outdoor heat exchanger	-	-	m ³ /h
Annual energy consumption	Q_{HE}	5106	kWh or GJ				
For mixed central heating appliances with a heat pump							
Stated load profile	XL			Water central heating energy efficiency	η_{wh}	105	%
Daily electrical power consumption	Q_{elec}	7,46	kWh	Daily fuel consumption	Q_{fuel}	-	kWh
Annual energy consumption	AEC	1595	kWh	Annual fuel consumption	AFC	-	GJ
Contact information	Immergas S.p.A. via Cisa Figure n.95						

INSTALLER

USER

MAINTENANCE TECHNICIAN

TECHNICAL DATA



4.6 PARAMETERS FOR FILLING IN THE PACKAGE FICHE

Should you wish to install an assembly starting from the Magis Hercules Pro Mini EH package, use the package fiche shown in (Fig. 55). To fill it in correctly, enter the figures shown in tables in par. "Parameters to fill in the low temperature package fiche (30/35)", "Parameters to fill in the average temperature package fiche (47/55)" (as shown in the package fiche facsimile Fig. 54).

The remaining values must be obtained from the technical data sheets of the products used to make up the assembly (e.g. solar devices, integration heat pumps, temperature controllers).

Use board (Fig. 55) for "assemblies" related to the central heating mode (e.g.: heat pump + temperature controller).



Since the product is standard supplied with a temperature controller, the package fiche must always be completed.

Facsimile for filling in the package fiche for room central heating systems.

Room central heating seasonal energy efficiency of the heat pump %

Temperature control %
 From temperature control board

Class I = 1 %, Class II = 2 %,
 Class III = 1.5 %, Class IV = 2 %,
 Class V = 3 %, Class VI = 4 %,
 Class VII = 3.5 %, Class VIII = 5 %

Supplementary boiler %
 From boiler board

Seasonal central heating energy efficiency of the room (%)

(- 'I') x "II" = - %

Solar contribution

From the board of the solar device

Dimensions of the manifold (in m²)
 Volume of the tank (in m³)
 Efficiency of the manifold (in %)
 Classification of the tank
 A* = 0.95, A = 0.91,
 B = 0.86, C = 0.83,
 D-G = 0.81

('III' x + 'IV' x) x 0.45 x (/ 100) x = + %

Room central heating seasonal energy efficiency of the assemble in average climate conditions %

Room central heating seasonal energy efficiency class of the assemble in average climate conditions

G **F** **E** **D** **C** **B** **A** **A⁺** **A⁺⁺** **A⁺⁺⁺**

< 30 % ≥ 30 % ≥ 34 % ≥ 36 % ≥ 75 % ≥ 82 % ≥ 90 % ≥ 98 % ≥ 125 % ≥ 150 %

Room central heating seasonal energy efficiency in colder and hotter climate conditions

Colder: - 'V' = % Hotter: + 'VI' = %

The energy efficiency of the set of products indicated in this sheet may not reflect the actual energy efficiency after installation since such efficiency is affected by additional factors, such as the heat loss in the distribution system and the size of the products compared to the size and features of the building.



Parameters to fill in the low temperature package fiche (30/35)

MAGISHERCULES PRO MINI 6 EH

Parameter	Colder zones	Average zones	Hotter zones
	■	■	■
"I"	140	178	235
"II"	*	*	*
"III"	5,35	4,45	4,45
"IV"	2,09	1,74	1,74

MAGISHERCULES PRO MINI 9 EH

Parameter	Colder zones	Average zones	Hotter zones
	■	■	■
"I"	137	175	241
"II"	*	*	*
"III"	3,34	3,34	2,97
"IV"	1,31	1,31	1,16

Parameters to fill in the average temperature package fiche (47/55)

MAGISHERCULES PRO MINI 6 EH

Parameter	Colder zones	Average zones	Hotter zones
	■	■	■
"I"	94	128	151
"II"	*	*	*
"III"	5,35	4,45	4,45
"IV"	2,09	1,74	1,74

MAGISHERCULES PRO MINI 9 EH

Parameter	Colder zones	Average zones	Hotter zones
	■	■	■
"I"	94	126	154
"II"	*	*	*
"III"	3,82	3,34	3,34
"IV"	1,49	1,31	1,31

* to be determined according to Regulation 811/2013 and transient calculation methods as per Notice of the European Community no. 207/2014.



Room central heating system package fiche.

Room central heating seasonal energy efficiency of the heat pump

%

Temperature control
From temperature
control board

Class I = 1 %, Class II = 2 %,
Class III = 1.5 %, Class IV = 2 %,
Class V = 3 %, Class VI = 4 %,
Class VII = 3.5 %, Class VIII = 5 %

+ %

Supplementary boiler
From boiler board

Seasonal central heating energy efficiency of the room (%)

(- _____) x _____ = - %

Solar contribution

From the board of the solar device

Dimensions of the manifold (in m²)

Volume of the tank (in m³)

Efficiency of the manifold (in %)

Classification of the tank
A* = 0.95, A = 0.91,
B = 0.86, C = 0.83,
D-G = 0.81

(___ x + ___ x) x 0.45 x (/ 100) x = + %

Room central heating seasonal energy efficiency of the assemble in average climate conditions

%

Room central heating seasonal energy efficiency class of the assemble in average climate conditions

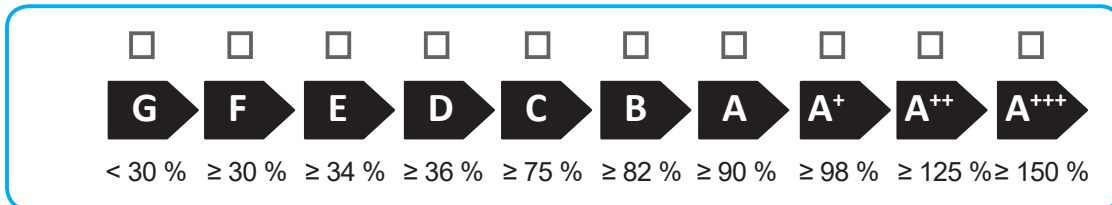

Room central heating seasonal energy efficiency in colder and hotter climate conditions

Colder: - ___ = %

Hotter: + ___ = %

The energy efficiency of the set of products indicated in this sheet may not reflect the actual energy efficiency after installation since such efficiency is affected by additional factors, such as the heat loss in the distribution system and the size of the products compared to the size and features of the building.

INSTALLER

USER

MAINTENANCE TECHNICIAN

TECHNICAL DATA



Immergas S.p.A.

42041 Brescello (RE) - Italy

Tel. 0522.689011

immergas.com



This instruction booklet is made of ecological paper.

