

MAJOR'S
USERS

Instructions and recommendations

Installer



User



Maintenance technician

L04889ENG



**VICTRIX MAIOR
35 PLUS**



INDEX

Dear Customer.....	4
General Recommendations.....	5
Safety symbols used.....	6
Personal protective equipment	6
1 Unit installation	7
1.1 Installation warnings	7
1.2 Main dimensions	14
1.3 Minimum installation distances.....	15
1.4 Antifreeze protection	16
1.5 Installation inside the recessed frame (Optional).....	17
1.6 Appliance connection unit.....	18
1.7 Gas connection.....	19
1.8 Hydraulic connection.....	21
1.9 Cyclonic filter unit.....	22
1.10 Electrical connection.....	24
1.11 Remote controls and room chrono-thermostats (Optional)	26
1.12 External temperature probe (Optional).....	27
1.13 General examples of types of installation of flue systems	28
1.14 Immergas flue systems.....	30
1.15 Equivalent lengths of "Green Range" flue system components.....	32
1.16 Maximum flue length	38
1.17 Outdoor installation in partially protected area.....	40
1.18 Internal installation using a recessed frame with direct air intake	43
1.19 Concentric horizontal kit installation	44
1.20 Concentric vertical kit installation	48
1.21 Separator kit installation.....	53
1.22 Adaptor kit installation C ₉	56
1.23 Configuration C ₍₁₅₎ concentric kit.....	58
1.24 Configuration C ₍₁₀₎ concentric kit (Ø 80/125).....	59
1.25 Configuration C ₍₁₀₎ - C ₍₁₂₎ separator kit (Ø 80/80)	62
1.26 Ducting of flues or technical slots	67
1.27 Configuration for C ₆ flue installation.....	68
1.28 Configuration type B, open chamber and fan assisted for indoors	69
1.29 Flue exhaust to flue/chimney.....	69
1.30 Flues, chimneys and chimney caps.	70
1.31 Water treatment plant filling.....	71
1.32 System filling	72
1.33 Filling the condensate drain trap.....	72
1.34 Gas system start-up.....	72
1.35 Appliance start-up (Ignition).....	73
1.36 UPM4 circulation pump.....	74
1.37 Kits available on request	76
1.38 Main components	77
2 Instructions for use and maintenance	78
2.1 General recommendations	78
2.2 Cleaning and maintenance	80
2.3 Control panel.....	81
2.4 Using the appliance.....	82
2.5 Fault and anomaly signals	86
2.6 Information menu.....	92
2.7 Appliance switch-off.....	93

2.8	Restore central heating system pressure	93
2.9	Draining the system	94
2.10	Antifreeze protection	94
2.11	Prolonged inactivity	94
2.12	Cleaning the case	94
2.13	Cleaning the keyboard.....	94
2.14	Permanent shutdown.....	95
2.15	Automatic vent mode.....	95
3	Instructions for maintenance and initial check.....	96
3.1	General recommendations	96
3.2	Initial check	97
3.3	Yearly appliance check and maintenance	98
3.4	Hydraulic diagram.....	100
3.5	Wiring diagram.....	101
3.6	Removable memory	103
3.7	Troubleshooting.....	104
3.8	Converting the appliance to other types of gas.....	105
3.9	Calibration type involving the replacement of a component.....	106
3.10	Automatic calibration function (TA).....	107
3.11	Manual calibration function (TM)	109
3.12	Flue test.....	112
3.13	P.C.B. programming.....	113
3.14	Password-protected special functions.....	123
3.15	Screed heater	124
3.16	Maintenance function (MA).....	126
3.17	Automatic vent function (dl).....	127
3.18	Flue installation (FU).....	127
3.19	Chimney sweep	128
3.20	Pump anti-block.....	128
3.21	Three-way anti-block.....	128
3.22	Radiator antifreeze	128
3.23	Casing removal.....	129
3.24	Replacing the manifold insulating panel.....	132
3.25	Assembly of manifold gasket on condensation module	134
3.26	Assembling the manifold on the condensation module.....	135
3.27	Specific information for correct appliance installation in common pressurised flue systems (C ₍₁₀₎ - C ₍₁₂₎)	136
4	Technical data.....	137
4.1	Variable heat output	137
4.2	Combustion parameters	138
4.3	Technical data table.....	139
4.4	Data nameplate and installation information sticker key.....	140
4.5	Technical parameters for combination boilers (in compliance with Regulation 813/2013).....	141
4.6	Product fiche (in compliance with Regulation 811/2013).....	142
4.7	Parameters for filling in the package fiche	143

Dear Customer

Congratulations for having chosen a top-quality Immergas product, able to assure well-being and safety for a long period of time. As an Immergas customer you can also count on a Qualified Authorised After-Sales Technical Assistance Centre, prepared and updated to guarantee the constant efficiency of your products. Read the following pages carefully: you will be able to draw useful tips on the proper use of the device, compliance with which will confirm your satisfaction with the Immergas product.

For assistance and routine maintenance, contact Authorised Technical Service Centres: they have original spare parts and are specifically trained directly by the manufacturer.

The company **IMMERGAS S.p.A.**, with registered office in via Cisa Ligure 95 42041 Brescello (RE), declares that the design, manufacturing and after-sales assistance processes comply with the requirements of standard **UNI EN ISO 9001:2015**.

For further details on the product CE marking, request a copy of the Declaration of Conformity from the manufacturer, specifying the appliance model and the language of the country.

The manufacturer declines all liability due to printing or transcription errors, reserving the right to make any modifications to its technical and commercial documents without forewarning.



GENERAL RECOMMENDATIONS

This book contains important information for the:

Installer (section 1);

User (section 2);

Maintenance Technician (section 3).

- The user must carefully read the instructions in the specific section (section 2).
 - The user must limit operations on the appliance only to those explicitly allowed in the specific section.
 - The appliance must be installed by qualified and professionally trained personnel.
 - The instruction booklet is an integral and essential part of the product and must be given to the new user in the case of transfer or succession of ownership.
 - It must be stored with care and consulted carefully, as all of the warnings provide important safety indications for installation, use and maintenance stages.
 - In compliance with the legislation in force, the systems must be designed by qualified professionals, within the dimensional limits established by the Law. Installation and maintenance must be performed in compliance with the regulations in force, according to the manufacturer's instructions and by professionally qualified staff, meaning staff with specific technical skills in the plant sector, as provided for by Law.
 - Improper installation or assembly of the Immergas device and/or components, accessories, kits and devices can cause unexpected problems for people, animals and objects. Read the instructions provided with the product carefully to ensure proper installation.
 - This instructions manual provides technical information for installing Immergas products. As for the other issues related to the installation of products (e.g. safety at the workplace, environmental protection, accident prevention), it is necessary to comply with the provisions of the standards in force and the principles of good practice.
 - All Immergas products are protected with suitable transport packaging.
 - The material must be stored in a dry place protected from the weather.
 - Damaged products must not be installed.
 - Maintenance must be carried out by skilled technical staff. For example, the Authorised Service Centre that represents a guarantee of qualifications and professionalism.
 - The appliance must only be destined for the use for which it has been expressly declared. Any other use will be considered improper and therefore potentially dangerous.
 - If errors occur during installation, operation and maintenance, due to non-compliance with technical laws in force, standards or instructions contained in this booklet (or however supplied by the manufacturer), the manufacturer is excluded from any contractual and extra-contractual liability for any damages and the device warranty is invalidated.
 - In the event of malfunctions, faults or incorrect operation, turn the appliance off and contact an authorised company (e.g. the Authorised Technical Assistance Centre, which has specifically trained staff and original spare parts). Do not attempt to modify or repair the appliance alone.
-

SAFETY SYMBOLS USED



GENERIC HAZARD

Strictly follow all of the indications next to the pictogram. Failure to follow the indications can generate hazard situations resulting in possible harm to the health of the operator and user in general, and/or property damage.



ELECTRICAL HAZARD

Strictly follow all of the indications next to the pictogram. The symbol indicates the appliance's electrical components or, in this manual, identifies actions that can cause an electrical hazard.



MOVING PARTS

The symbol indicates the appliance's moving components that can cause hazards.



DANGER OF HOT SURFACES

The symbol indicates the appliance's very hot components that can cause burns.



WARNINGS

Strictly follow all of the indications next to the pictogram. Failure to follow the indications can generate hazard situations resulting in possible minor injuries to the health of both the operator and the user in general, and/or slight material damage.



ATTENTION

Read and understand the instructions of the appliance before carrying out any operation, carefully following the instructions given. Failure to observe the instructions may result in malfunction of the unit.



INFORMATION

Indicates useful tips or additional information.



EARTH TERMINAL CONNECTION

The symbol identifies the appliance's earth terminal connection point.



DISPOSAL WARNING

The user must not dispose of the appliance at the end of its service life as municipal waste, but send it to appropriate collection centres.

PERSONAL PROTECTIVE EQUIPMENT



SAFETY GLOVES



EYE PROTECTION



SAFETY FOOTWEAR

1 UNIT INSTALLATION

1.1 INSTALLATION WARNINGS



Operators who install and service the appliance must wear the personal protective equipment required by applicable law.



This appliance has been designed for wall mounted installation only, for central heating and production of domestic hot water for domestic use and similar purposes.



The place of installation of the appliance and relative Immergas accessories must have suitable features (technical and structural), such as to allow for (always in safe, efficient and comfortable conditions):

- installation (according to the provisions of technical legislation and technical regulations);
- maintenance operations (including scheduled, periodic, routine and special maintenance);
- removal (to outdoors in the place for loading and transporting the appliances and components) as well as the eventual replacement of those with appliances and/or equivalent components.



By varying the type of installation the classification of the appliance and precisely:

- **Type B₂₃ or B₅₃** appliance if installed using the relevant terminals for air intake directly from the room in which the appliance has been installed.
- **Type C appliance** if installed using concentric pipes or other types of pipes envisioned for the sealed chamber appliance for intake of air and expulsion of flue gas.



Installation must be carried out according to regulation standards, current legislation and in compliance with local technical regulations and the required technical procedures.



The equipment classification is shown in the illustrations of the various installation solutions on the following pages.



Only professionally enabled companies are authorised to install Immergas gas appliances.

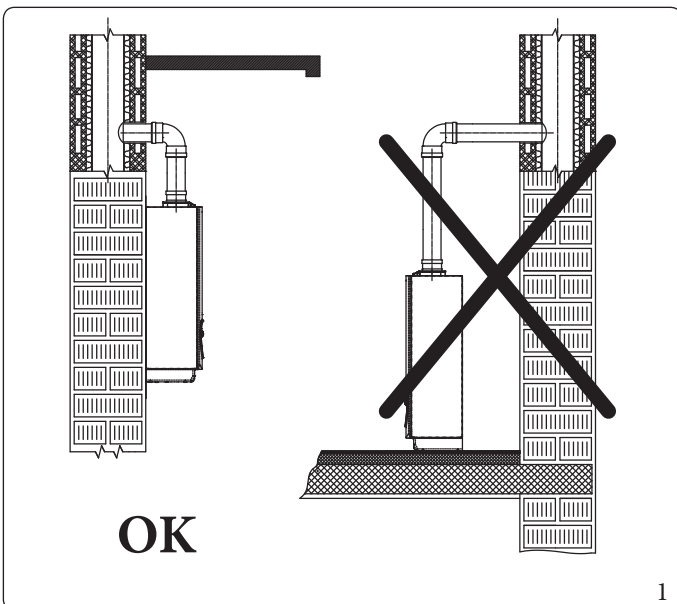

The wall surface must be smooth, without any protrusions or recesses enabling access to the rear part. They are not designed to be installed on plinths or floors (Fig. 1).



It is forbidden to install appliances removed from other systems.

The manufacturer declines all liability in the event of damage caused by appliances removed from other systems or for any non-conformities with such equipment.



Check the environmental operating conditions of all parts relevant to installation, referring to the values shown in the technical data table in this booklet.



If installing a kit or servicing the appliance, always empty the system's circuit first so as not to compromise the appliance's electrical safety (Parag. 2.9).

Always disconnect the appliance from voltage and, depending on the type of operation, decrease the pressure and/or bring it to zero in the gas and DHW circuits (when combined with a Storage Tank Unit).



Installation of the appliance when powered by LPG or propane air must comply with the rules regarding gases with a greater density than air (remember, as an example, that it is prohibited to install plants powered with the above-mentioned gas in rooms where the floor is at a lower quota than the country level).



Before installing the appliance, ensure that it is delivered in perfect condition; if in doubt, contact the supplier immediately.

Packing materials (staples, nails, plastic bags, polystyrene foam, etc.) constitute a hazard and must be kept out of the reach of children.

If the appliance is installed inside or between cabinets, ensure sufficient space for routine servicing; for minimum installation distances, see Fig. 3.



It is just as important that the intake grids and exhaust terminals are not obstructed.



Check that no flue gas recirculation is found in the air sample points. Allow the appliance to reach the maximum heat output; the CO₂ value measured in the air must be less than 10% of that measured on the flue gas.



The minimum distance for exhaust pipes from flammable materials must be at least 25 cm.



Keep all combustible material away from the appliance (paper, rags, plastic, polystyrene, etc.).



Split exhaust ducts must not pass through walls of combustible material.



Do not place household appliances underneath the appliance as they could be damaged if the safety valve intervenes, if the drain trap is blocked, or if there are leaks from the hydraulic connections; otherwise, the manufacturer cannot be held responsible for any damage caused to the household appliances.



For the aforementioned reasons, we recommend not placing furnishings, furniture, etc. under the appliance.



In the event of malfunctions, faults or incorrect operation, turn the appliance off and contact an authorised company (e.g. the Authorised Technical Assistance Centre, which has specifically trained staff and original spare parts). Do not attempt to modify or repair the appliance alone.



Any modification to the appliance that is not explicitly indicated in this section of the booklet is forbidden.

INSTALLER

USER

MAINTENANCE TECHNICIAN

TECHNICAL DATA

Installation standards



This appliance can be installed outdoors in a partially protected area.
By partially protected area, we mean one in which the unit is not directly exposed to the elements (rain, snow, hail, etc.).



This type of installation is possible when permitted by the laws in force in the appliance's country of destination.



Installation of gas appliances, flue exhaust pipes and combustion air intake pipes is forbidden in places with a fire risk (for example: garages, closed parking stalls), and in potentially dangerous places.



Do not install in places/rooms that constitute public areas of apartment buildings, internal stairways or other escape routes (e.g. floor landings, entrance halls, etc.).



These appliances, if not adequately isolated, are not suitable for installation on walls of combustible material.



Installation is also forbidden in places/rooms that constitute public areas of apartment buildings such as cellars, entrance halls, attics, lofts, etc., unless otherwise provided for by local regulations in force.



Installing the wall recessed frame kit must guarantee the boiler stable, efficient support.

The recessed frame kit ensures appropriate support only if installed correctly (according to the rules of good practice), following the instructions on its instructions leaflet.

For safety reasons against any leaks it is necessary to plaster the boiler housing in the brick wall.

The recessed frame for the boiler is not a supporting structure and must not replace the wall removed. It is necessary to position the boiler inside the wall.



Wall mounting of the appliance must guarantee stable and efficient support for the generator.

The plugs (standard supply) that come with the appliance are only to be used to fix the latter to the wall; they only ensure adequate support if inserted correctly (according to technical standards) in walls made of solid or semi-hollow brick or block. In the case of walls made from hollow brick or block, partitions with limited static properties, or in any case walls other than those indicated, a static test must be carried out to ensure adequate mount. Appliances must be installed in such a way as to avoid knocks or tampering.



These appliances are used to heat water to below boiling temperature in atmospheric pressure.



They must be connected to a central heating system and domestic hot water circuit suited to their performance and capacity.



The storage tank unit, if present, must also be installed in an environment in which the temperature cannot fall below 0°C.

Risk of damage due to corrosion caused by unsuitable combustion air and environment.

Spray, solvents, chlorine-based detergents, paints, glue, ammonium compounds, powders and similar cause product and flue duct corrosion.



Check that combustion air power supply is free from chlorine, sulphur, powders, etc.



Make sure that no chemical substances are stored in the place of installation.



If you want to install the product in beauty salons, paint workshops, carpenter's shop, cleaning companies or similar, choose a separate installation area that ensures combustion air supply that is free from chemical substances.



Make sure the combustion air is not fed through chimneys that were previously used with boilers or other central heating appliances powered by liquid or solid fuels. In fact, these may cause an accumulation of soot in the chimney

Risk of material damage after using sprays and liquids to search for leaks

Leak sprays and liquids clog the reference hole P.Ref. (Fig. 70) of the gas valve, damaging it irreparably.
During installation and maintenance, do not use spray or liquids in the upper area of the gas valve (electric connections side).

Filling the condensate drain trap

When the appliance is switched on for the first time, combustion products come out of the condensate drain. After a few minutes of operation, check that combustion flue gases are no longer coming out of the condensate drain; this means that the drain trap has filled to a correct condensate height that the flue gases cannot pass through.

Special provisions for appliances installed in B₂₃ or B₅₃ configuration.



Open chamber appliances type B₂₃ and B₅₃ must not be installed in rooms in which commercial, craft or industrial activities are carried out where products are used that are capable of developing vapours or volatile substances (e.g. acid vapours, glues, paints, solvents, fuels, etc.), as well as dust (e.g. dust from wood processing, coal dust, cement dust, etc.) that could be harmful to the appliance's components and impair its operation.



In configuration B₂₃ and B₅₃, unless local regulations are in force, the appliances must not be installed in bedrooms, bathrooms, toilets or studios; they must neither be installed in rooms containing solid fuel heat generators nor in rooms communicating with said rooms.



For appliances for domestic use (up to 35 kW) in B₂₃ and B₅₃ configuration, the installation rooms must be permanently ventilated, in compliance with the local regulations in force (at least 6 cm² for each kW of heat input installed, except in the case of the presence of electromechanical extractor fans or other devices that can depressurise the installation room).



Install the appliances in B₂₃ and B₅₃ configuration in non-residential premises and which are permanently ventilated.



Failure to comply with the above implies personal responsibility and invalidates the warranty.

INSTALLER

USER

MAINTENANCE TECHNICIAN

TECHNICAL DATA

1.2 MAIN DIMENSIONS

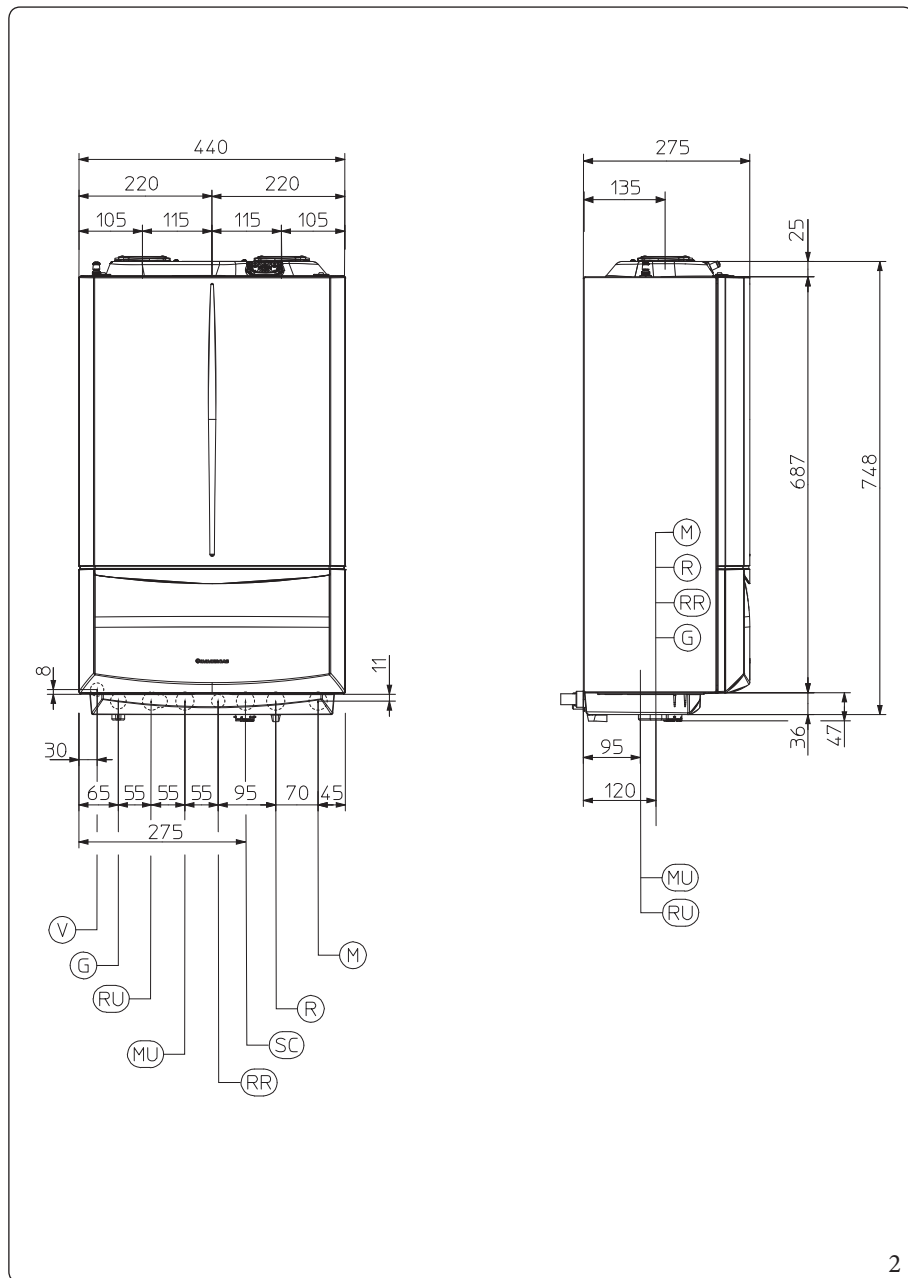

Key (Fig. 2):

- V - Electrical connection
- G - Gas supply
- RU - Storage tank unit return
- MU - Storage tank unit flow
- RR - System filling
- SC - Condensate drain (minimum internal diameter Ø 13 mm)
- R - System return
- M - System flow

Height (mm)		Width (mm)	Depth (mm)
748		440	275
TEMPLATE CONNECTIONS			
SYSTEM		GAS	DOMESTIC HOT WATER
MU-RU	M-R	G	RR
3/4"	3/4"	3/4"	1/2"

1.3 MINIMUM INSTALLATION DISTANCES

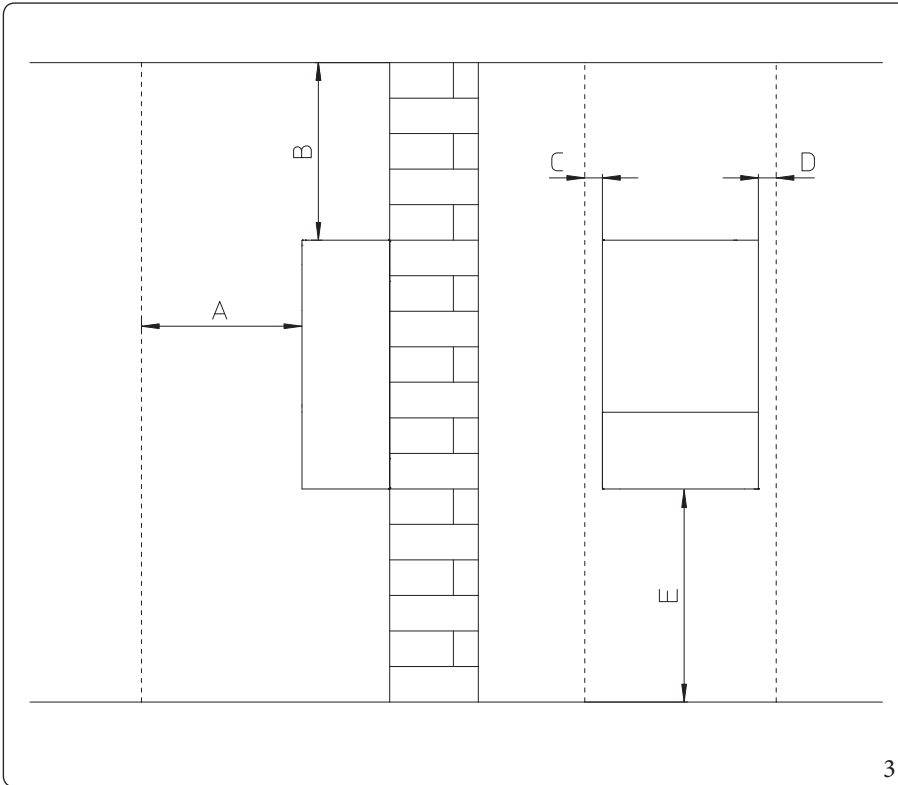

Key (Fig. 3):

- A - 450 mm
- B - 350 mm
- C - 30 mm
- *D - 100 mm
- E - 600 mm

NOTE:

*: This distance is necessary to install the cyclonic filter with a normal spanner. It can be reduced to 30 mm using a special spanner. Contact the Immergas toll-free number or the Authorised Technical Service Centre.

INSTALLER

USER

MAINTENANCE TECHNICIAN

TECHNICAL DATA

1.4 ANTIFREEZE PROTECTION

Appliance antifreeze protection is thus only ensured if:

- the appliance is correctly connected to gas and electricity power supply circuits;
- the appliance is powered constantly;
- the appliance has the antifreeze function active (P.8 = 0);
- the appliance is not in anomaly conditions (Par.2.5);
- the appliance essential components are not faulty.

To prevent the risk of freezing follow the instructions below:

- Protect the central heating circuit from freezing by inserting a good-quality antifreeze liquid into this circuit, which is specially suited for central heating systems and which is manufacturer guaranteed not to cause damage to the heat exchanger or other components of the appliance. The antifreeze liquid must not be harmful to one's health. The instructions of the manufacturer of this liquid must be strictly followed regarding the necessary percentage with respect to the minimum temperature at which the system must be kept.
- The materials used for the central heating circuit of Immergas appliances resist propylene glycol based antifreeze liquids (if the mixtures are prepared perfectly).
- An aqueous solution must be made with potential pollution class of water 2 (EN 1717:2002 or local standards in force).



Follow the supplier's instructions for the life cycle duration and possible disposal of the anti-freeze liquid.



The water in the storage tank unit (if present) is not protected against freezing when the appliance is switched off.



The antifreeze systems described in this chapter are only to protect the appliance; the presence of these functions and devices does not exclude the possibility of parts of the system or domestic hot water circuit outside the appliance from freezing.



The excessive use of glycol could jeopardise the proper functioning of the appliance.

Minimum room temperature -5°C

Insulate the visible pipes and fittings with 10 mm thick insulating material (cooling inlet pipe, heating outlet pipe and condensate draining pipe).

The appliance comes as per standard with an antifreeze function that activates the pump and the burner when the system water temperature in the appliance falls below 4°C.



In these conditions, previously listed, the appliance is protected against freezing up to an ambient temperature of -5°C.



If the appliance is installed in a place where the temperature drops below -5°C, the appliance may freeze.



When installing the appliance in locations where the temperature falls below -5°C, installation of the antifreeze kit is required, respecting all the conditions listed above.

Minimum room temperature -15°C

Protect the domestic hot water circuit (when paired with a storage tank unit) against freezing by using an accessory that is supplied on request (antifreeze kit) comprising an electric resistance, the relevant wiring and a control thermostat (carefully read and follow the installation instructions contained in the accessory kit pack).



In the previously listed conditions and with the addition of the antifreeze kit, the appliance is protected against freezing up to a temperature of -15°C.

1.5 INSTALLATION INSIDE THE RECESSED FRAME (OPTIONAL)

The unit is designed for installation inside the Immergas recessed frame (supplied as an optional extra) only in combination with the oversized door kit that also contains the brackets for installation.

To install proceed as follows:

- for mounting the oversized door, please refer to the relevant instruction sheet
- Install the bracket (2) inside the recessed frame fixing it with the screws (3) in the pre-drilled holes (Fig. 4).
- Hang the boiler (4) to the bracket (2) (Fig. 5).
- Secure the boiler (4) by fitting the brackets (5) and fastening them with the relevant screws (6) and replace the door (Fig. 6).

The brackets (5) used to centre the appliance on the frame and hold it in place stop against the frame (1) so do not require fixing to the frame itself.

An optional hose kit is available to connect the cyclonic filter supplied as standard. Contact the Immergas toll-free number or an Authorised Technical Service Centre.

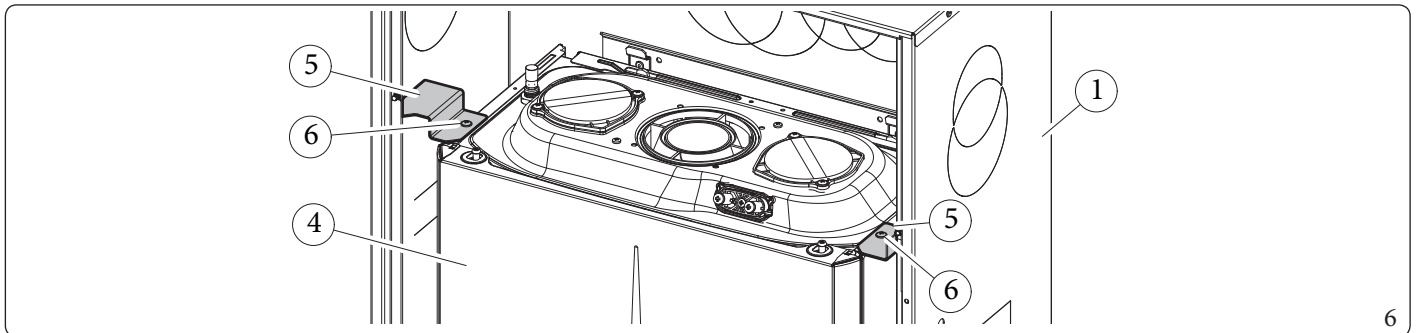
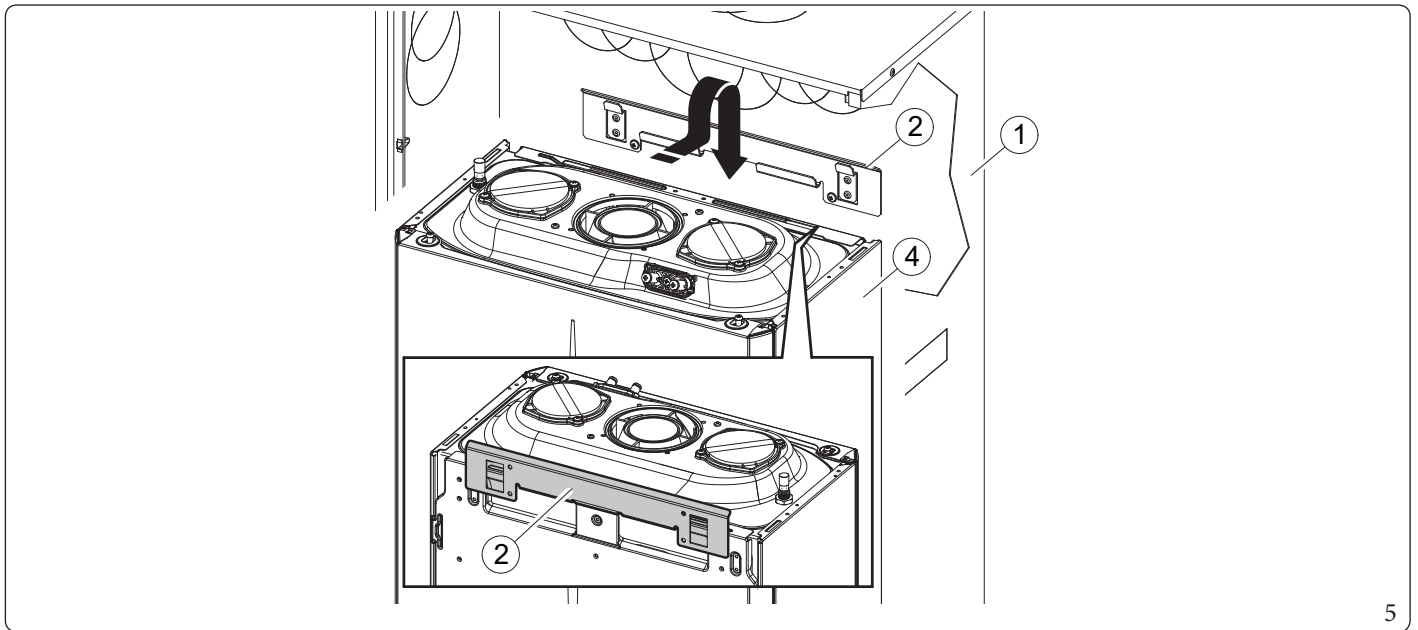
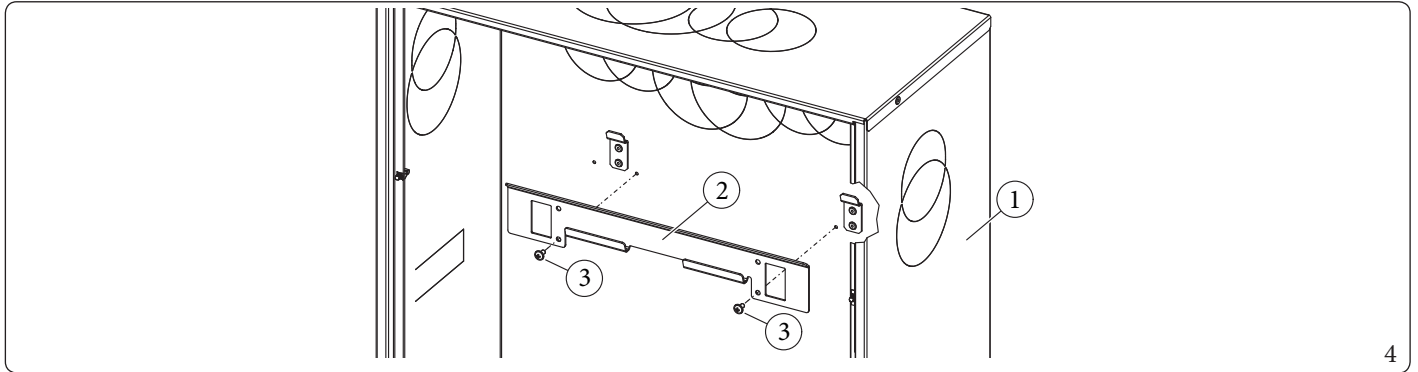

1.6 APPLIANCE CONNECTION UNIT

The connection unit consisting of all the necessary parts to perform the hydraulic and gas system connections of the appliance comes as standard with the boiler, perform the connections in accordance with the type of installation to be made and respecting the arrangement shown in figure 7.



In the case of installation in the recessed frame, the connection unit supplied as standard cannot be used.

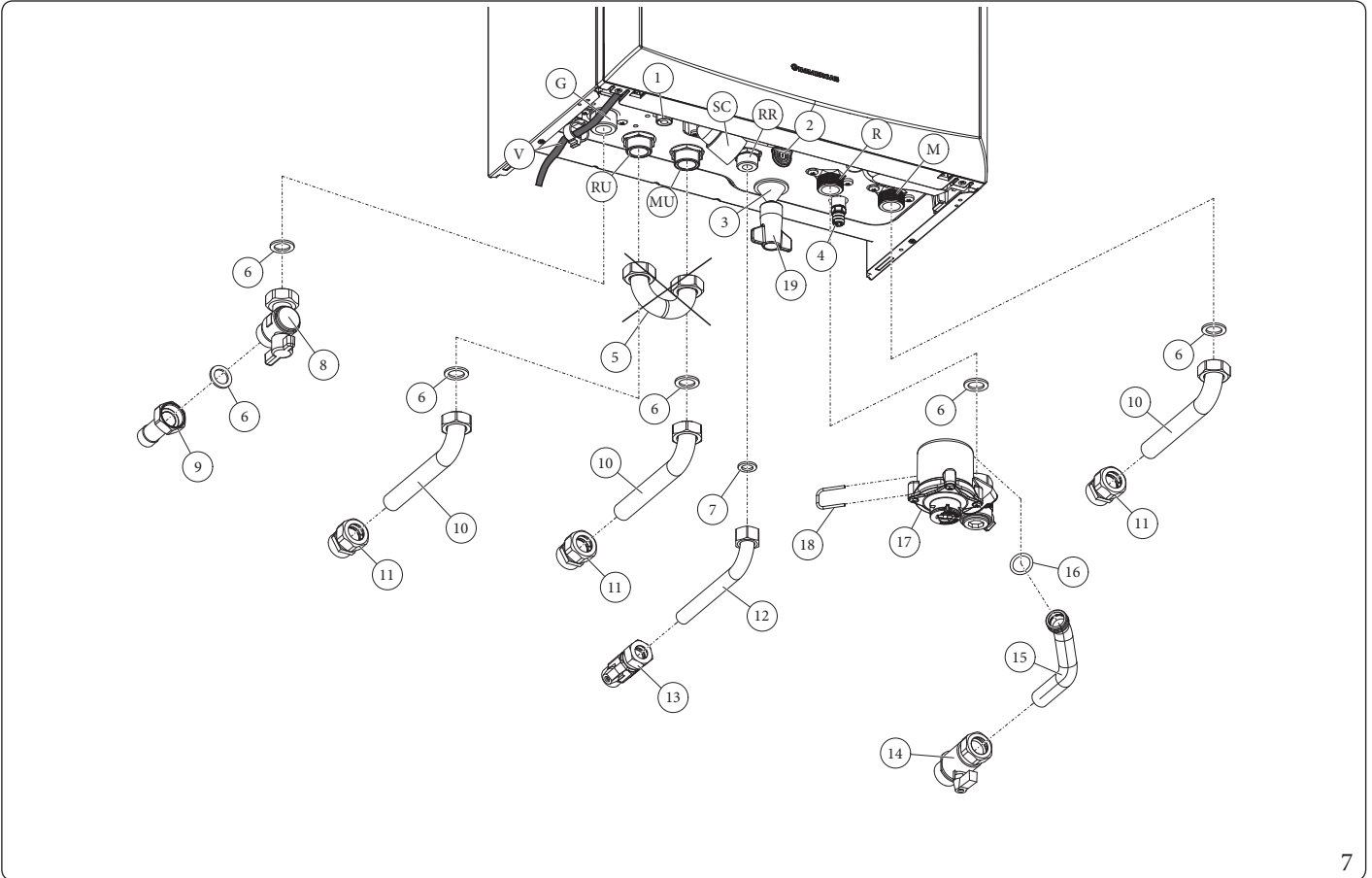

The unit includes:

- 1 - Air vent valve drain
- 2 - 3 bar safety valve drain fitting signal
- 3 - System filling valve connection
- 4 - System draining valve
- 5 - Storage tank unit bypass pipe, to be used only in case of boiler operating in room heating mode only
- 6 - G 3/4" Gaskets
- 7 - Gasket G 1/2"
- 8 - Angled tap G 3/4"
- 9 - Copper shank Ø18 mm
- 10 - Copper connection pipes Ø18 mm
- 11 - Vabco fittings G 3/4"
- 12 - Copper connection pipe Ø14 mm
- 13 - G 1/2" ball valve
- 14 - Tap G 3/4" connection to cyclonic filter unit

- 15 - Copper pipe Ø18 mm Cyclonic filter unit connection
- 16 - O-ring
- 17 - Cyclonic filter unit
- 18 - Cyclonic filter unit fork
- 19 - System filling valve knob with screw

Key (Fig. 7):

- V - Electrical connection
- G - 3/4" gas supply
- RU - 3/4" storage tank unit return
- MU - 3/4" storage tank unit flow
- RR - System filling 1/2"
- R - 3/4" system return
- M - 3/4" System flow
- SC - Condensate drain (minimum internal diameter Ø13 mm)

1.7 GAS CONNECTION

Our appliances are built to work with natural gas (G20), LPG and mixtures of methane and hydrogen at 20% in volume (20%H2NG), referred to the gas distributed in the network. Power supply pipes must be the same as or larger than the appliance fitting.



Before connecting the gas line, carefully clean inside all the fuel feed system pipes to remove any residue that could impair appliance efficiency.

Also make sure the gas corresponds to that for which the appliance is prepared (see appliance data nameplate).

If different, the boiler must be converted for operation with the other type of gas (see converting appliance for other gas types).

Data nameplate positioning

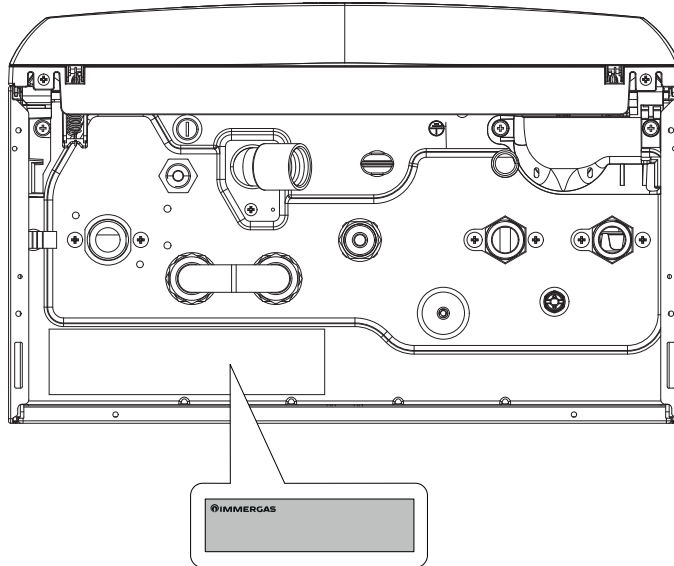

8



It is also important to check the dynamic pressure of the mains (methane or LPG) used to supply the boiler, which must comply with EN 437 and its attachment, as insufficient levels may reduce generator output and cause discomfort to the user.

Static/dynamic network pressures higher than those required for regular operation may cause serious damage to the appliance control elements; in this case shut the gas line off.

Do not operate the device.

Have the device checked by experienced personnel.



According to the local regulation in force, make sure that a gas isolation valve is installed upstream of each connection between the appliance and the gas system. This valve, if supplied by the appliance's manufacturer, can be directly connected to the appliance (i.e. downstream from the pipes connecting the system to the appliance), according to the manufacturer's instructions.

The Immergas connection unit, supplied as standard, also includes the gas isolation valve.

In any case, make sure the gas isolation valve is connected properly.

The gas supply pipe must be suitably dimensioned according to current regulations in order to guarantee correct gas flow rate to the burner even in conditions of maximum generator output and to guarantee appliance efficiency (technical specifications).

The coupling system must conform to standards in force (EN 1775).



The appliance is designed to operate with fuel gas free from impurities; otherwise it is advisable to fit special filters upstream of the appliance to restore the purity of the fuel.

Storage tanks (in case of supply from LPG depot).

- New LPG storage tanks may contain residual inert gases (nitrogen) that degrade the mixture delivered to the appliance causing functioning anomalies.
- Due to the composition of the LPG mixture, layering of the mixture components may occur during the period of storage in the tanks. This can cause a variation in the calorific value of the mixture delivered to the appliance, with subsequent change in its performance.

1.8 HYDRAULIC CONNECTION



In order not to void the condensation module warranty, before making the device connections, carefully clean the heating system (pipes, radiators, etc.) with special pickling or descaling products to remove any deposits that could compromise correct device operation.

A treatment of the heating and water system water is required, in compliance with the technical standards in force, in order to protect the system and the appliance from deposits (e.g. scale), slurry or other hazardous deposits.

In order not to void the heat exchanger warranty, you are required to comply with what has been prescribed in (Par. 1.31).

Hydraulic connections must be made in a rational way using the couplings on the appliance template.



The manufacturer declines all liability in the event of damage caused by the installation of an automatic filling system.

In order to meet the system requirements established by EN 1717 in terms of pollution of drinking water, we recommend installing the IMMERGAS anti-backflow kit to be used upstream of the cold water inlet connection of the appliance. We also recommend using category 2 heat transfer fluid (e.g.: water+ glycol) in the appliance's primary circuit (C.H. circuit), as defined in standard EN 1717.



To preserve the duration of appliance efficiency features, in the presence of water whose features can lead to the deposit of lime scale, installation of the "polyphosphate dispenser" kit is recommended.

The dispenser cannot be installed inside the recessed frame.

3 bar safety valve

Discharge of the safety valve has been conveyed to the condensate drain trap outlet. Consequently, in the event of valve intervention, the discharged liquid will end up in the sewer system through the drain pipe of the condensate drain trap.

In any case, the lower part of the appliance is fitted with a drain fitting (Ref. 2, Fig. 7) with the relative closure cap to check for the presence of liquid in the discharge circuit and to check the intervention of the 3 bar safety valve.

Condensate drain

To drain the condensate produced by the appliance, it is necessary to connect to the drainage system by means of acid condensate resistant pipes, with an internal Ø of at least 13 mm.

The system connecting the appliance to the drainage system must be carried out in such a way as to prevent occlusion and freezing of the liquid contained in it.

Before appliance ignition, ensure that the condensate can be correctly removed. After first ignition, check that the drain trap is filled with condensate (Parag. 1.33).

Also, comply with national and local regulations on discharging waste waters.

In the event condensate is not discharged into the wastewater drainage system, a condensate neutraliser must be installed to ensure compliance with the parameters established by the legislation in force.

1.9 CYCLONIC FILTER UNIT

The magnetic cyclonic filter is supplied as standard on the unit. Allows to detect the ferrous residues present in the system's water. Thanks to the two valves it facilitates maintenance by cleaning the filter without having to empty the circuit.

Install the cyclonic filter on the system return connection using the pipes as shown in the figure below (Fig. 9).

The wall connection pipe must be installed so that it exits orthogonally from the plug-in housing of the cyclonic filter. **It must not force laterally.**

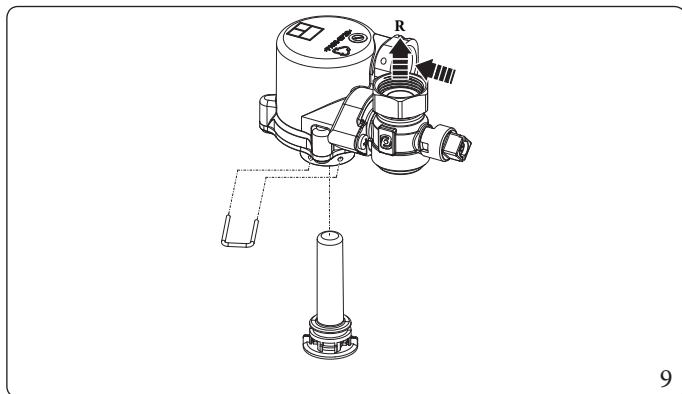

Key (Fig. 9):

R - System return

Head loss chart

The graph shows the head loss curve of the cyclonic filter.

Fig. 10:

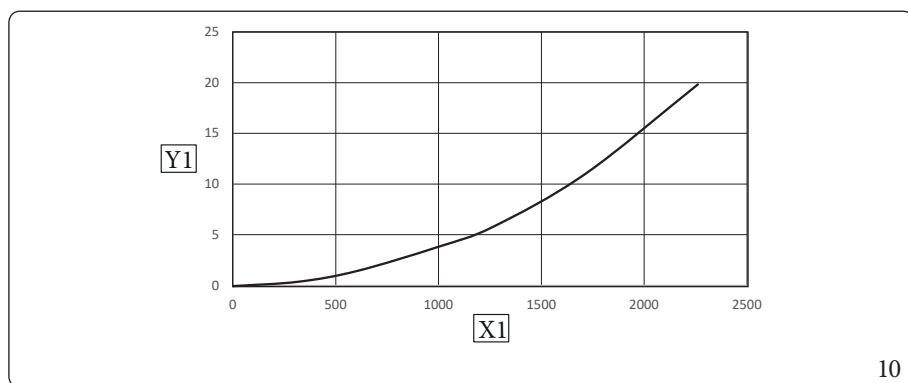

Key (Fig. 10):

X1 - Water flow rate (l/h)

Y1 - Head losses (kPa)

Cleaning the filter



Check that the temperature of the system return water is not too hot otherwise take precautions to avoid burns.

1. Place the container under the filter to collect the water contained in it.
2. Disconnect power to the appliance. Close the tap on the filter inlet pipe. Open the boiler drain cock until the pressure is zero, then close the second interception cock.
3. Place the container under the filter to collect the water contained in it.
4. Remove the clip and pull out the magnetic cartridge by pulling it downwards.
5. Clean the cartridge with a clean cloth and under running water.
6. Put the magnetic cartridge back in place, making sure that the centring pins match and that the sealing O-ring is not damaged. If necessary, replace it with a new one.
7. Lock the magnetic cartridge in place with the clip.
8. Open the two shut-off valves and restore power to the appliance to bring it back to normal operating conditions; at the same time check the operating pressure of the appliance and, if necessary, restore it to a correct value.

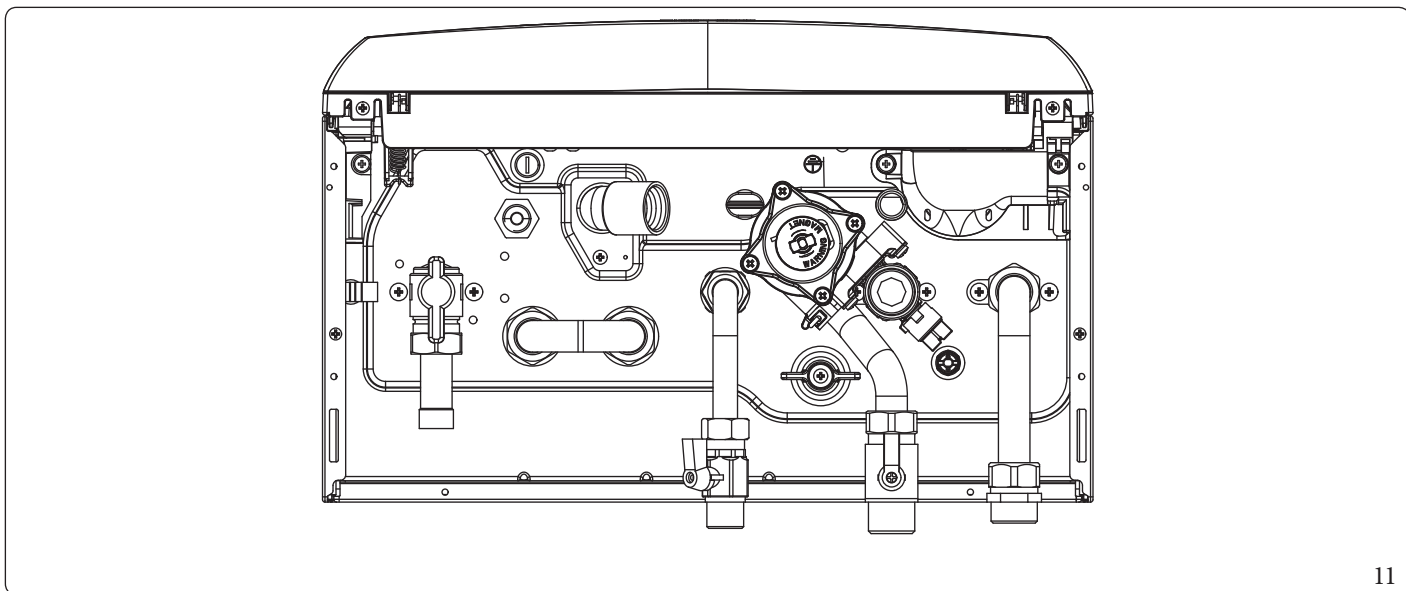

11

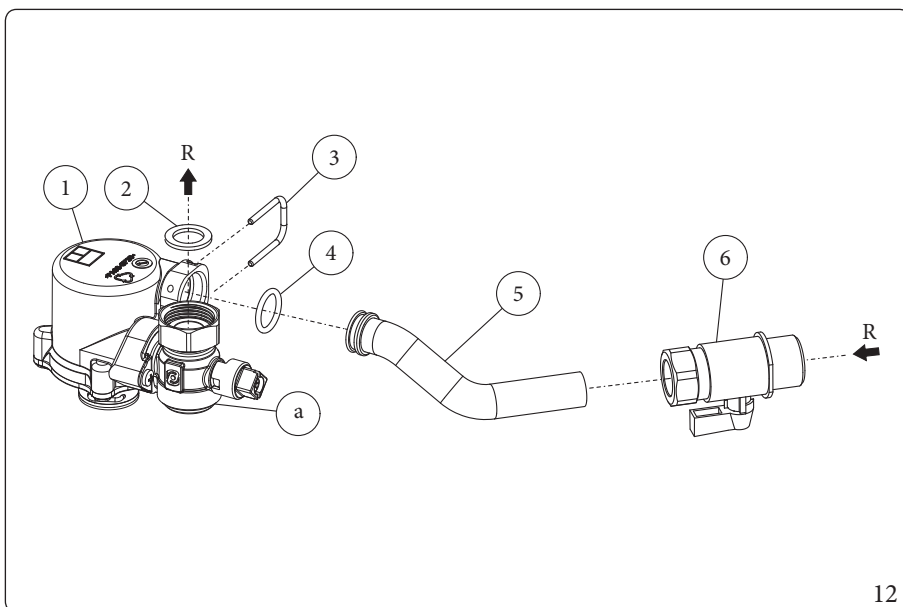

12

Key (Fig. 12):

- 1 - Cyclonic filter with interception valve (a)
- 2 - Flat gasket
- 3 - Flush fork
- 4 - O-Ring
- 5 - System return connection pipe
- 6 - Interception valve

1.10 ELECTRICAL CONNECTION

The appliance has an IPX5D protection degree; electrical safety of the appliance is achieved only when it is connected properly to an efficient earthing system, as specified by current safety standards.



The manufacturer declines any responsibility for damage or physical injury caused by failure to connect the appliance to an efficient earthing system or failure to comply with the IEC reference standards.

Open the control panel connections compartment (Fig. 13).



The power supply cable must be connected to a 230V \pm 10% / 50Hz mains supply respecting L-N polarity and earth connection; this network must also have a multi-pole circuit breaker with class III overvoltage category in compliance with installation regulations.

In order to make the electrical connections, it is necessary to remove the front casing as described in Parag.3.23 and then open the connection compartment according to the following instructions.

1. Loosen the screw (a) (Fig. 13).
2. Remove the faceplate (b) by pressing the side hooks.
3. Remove the faceplate (b) from the control panel (c).

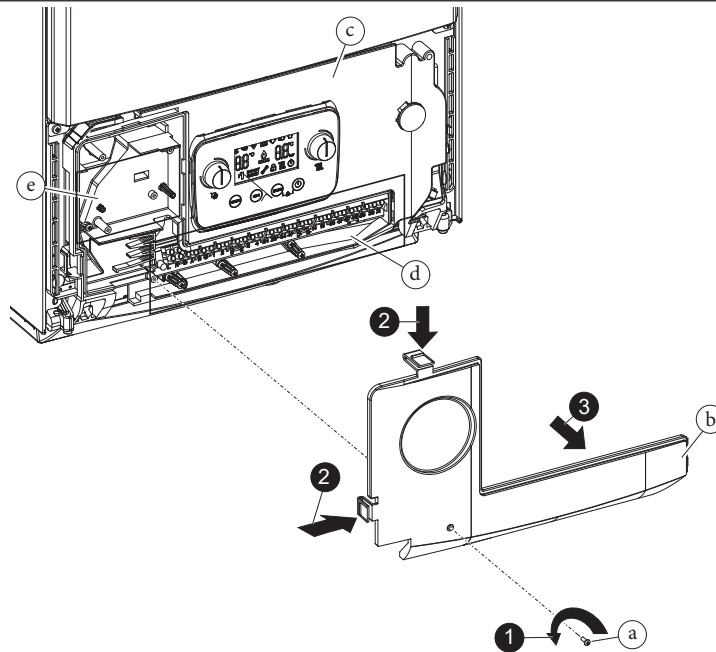

13

At this point, it is possible to access the terminal board (d).



The compartment (e) has cable clamps and screws to be used for connection of the optional external connections.

Also ensure that the electrical installation corresponds to maximum absorbed power specifications as shown on the appliance data nameplate.

The power supply cable must be laid as shown (Fig. 7).

The boilers are supplied complete with a "Y" type H05 VVF 3 x 0.75 mm² power supply cable, without plug.



To protect from possible dispersions of DC voltage, it is necessary to provide a type A differential safety device.



If the power cable is damaged, contact a qualified company (e.g. the Authorised Technical Assistance Centre) for its replacement to avoid a hazard.

If the network fuse on the P.C.B. needs replacing, this must also be done by qualified personnel: use a 5x20 250V 3.15 A fast fuse. For the main power supply to the appliance, never use adapters, multiple sockets or extension leads.



Connect terminals 36 and 37 to electrically connect the appliance and any storage tank unit, eliminating resistance R8 in the appliance (Fig. 68).

Installation with system operating at direct low temperature.

The boiler can directly supply a low temperature system by setting the flow temperature adjustment range "t0" and "t1" (Par. 3.13). In this situation it is good practice to insert a relevant safety kit (optional) made up from a thermostat (with adjustable temperature). Execute connection to terminal boards 14 and 15, eliminating jumper X70 (Fig. 68).

The thermostat must be positioned on the system flow pipe at a distance of at least 2 metres from the boiler.

Make sure that the contact is "dry", i.e. independent of the mains voltage, otherwise the P.C.B. would be damaged.

1.11 REMOTE CONTROLS AND ROOM CHRONO-THERMOSTATS (OPTIONAL)

The appliance is set up for room chrono-thermostats or remote controls, available as optional kits. Carefully read the user and assembly instructions contained in the accessory kit.



Disconnect power to the unit before making any electrical connections.

On/Off Immergas digital chrono-thermostat.

The chrono-thermostat allows:

- set two room temperature value: one for day (comfort temperature) and one for night (reduced temperature);
- set a weekly programme with four daily switch on and switch off times;
- selecting the required function mode from the various possible alternatives:
 - manual mode (with adjustable temperature);
 - automatic mode (with set programme);
 - forced automatic operation (momentarily changing the temperature of the automatic program).

The chrono-thermostat is powered by two 1.5V LR6 type alkaline batteries.

“Comando Amico Remoto” (Remote Control Device) v2 (CARv2) with climate chrono-thermostat function.

In addition to the functions described in the previous point, the CARv2 panel enables the user to control all the important information regarding operation of the appliance and the heating system with the opportunity to easily intervene on the previously set parameters, without having to go to where the appliance is installed.

The panel is equipped with self-diagnosis to show any appliance operating anomalies on the display.

The climate chrono-thermostat incorporated into the remote panel enables the system flow temperature to be adjusted to the actual needs of the room being heated, in order to obtain the desired room temperature with extreme precision and therefore with evident saving in running costs.

“Comando Amico Remoto” (Remote Control Device) v2 or On/Off chrono-thermostat electrical connection (Optional).



The operations described below must be performed after having removed the voltage from the appliance.

Any room thermostat or ON-OFF must be connected to terminals 40 and 41 eliminating link X40.

Any CARv2 must be connected to terminals 44 and 41 complying with the polarity **without eliminating link X40**.

Make sure that the On/Off thermostat contact is of the “clean” type, i.e. independent of the mains voltage, otherwise the P.C.B. would be damaged.



If the Comando Amico Remoto remote control v2 or any other On/Off chrono-thermostat is used arrange two separate lines in compliance with current regulations regarding electrical systems.

All appliance pipes must never be used to earth the electric or telephone system.

Ensure elimination of this risk before making the appliance electrical connections.

Dialogue to remote devices (Optional)



Any remote devices must be connected to terminals 44-41 **without eliminating link X40**.

To enable dialogue with non-Immergas remotes, you can set parameter P.17 (Parag. 3.13).

- **P.17 = 0 (IMGBUS)**: it is the default condition for correct communication with CARv2 devices. In this condition, the selection of operating mode, DHW set, CH set and CH demand are handled entirely by CARv2.
- **P.17 = 1**: It is possible to partially manage the DHW and CH function via the appliance. This type of dialogue is recommended for devices other than CARv2.

1.12 EXTERNAL TEMPERATURE PROBE (OPTIONAL)

The appliance is prepared for the application of the external probe (Fig. 14), which is available as an optional kit.

Refer to the relative instruction sheet for positioning of the external probe.

The probe can be connected directly to the appliance electrical system and allows the max. system flow temperature to be automatically decreased when the external temperature increases, in order to adjust the heat supplied to the system according to the change in external temperature.

The external probe always operates when connected, regardless of the presence or type of room chrono-thermostat used and can work in combination with Immergas chrono-thermostats.

The correlation between system flow temperature and external temperature is determined by the position of the central heating selector switch on the device control panel (or on the CA^{v2} control panel if connected to the boiler) according to the curves shown in the diagram (Fig.15).

The electric connection of the external probe must be made on terminals 38 and 39 on the terminal board on the appliance control panel (Fig. 68).



If the probe is used, it is mandatory to set up two separate lines in compliance with current regulations regarding electrical systems.

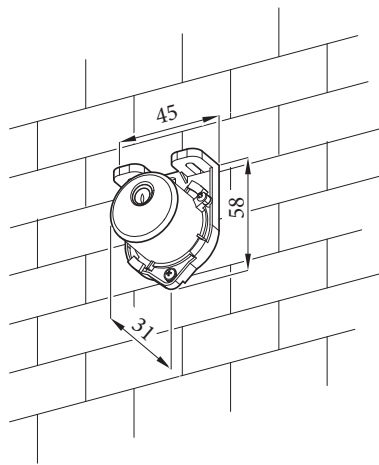

14

Correction law of the flow temperature depending on the external temperature and user adjustment of the central heating temperature.

* Position of the central heating temperature control.

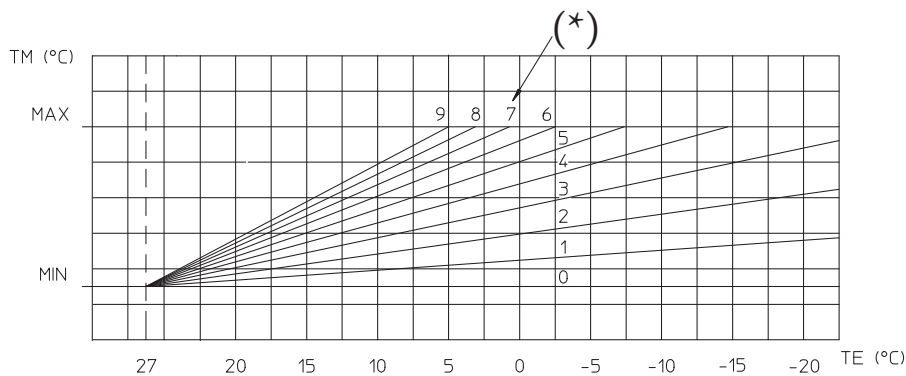

15

1.13 GENERALEXAMPLES OF TYPES OF INSTALLATION OF FLUE SYSTEMS



For the types of installation of the flue systems approved for this product, scrupulously follow what is indicated in the table in paragraph 4.3, in the “type of appliance” line.

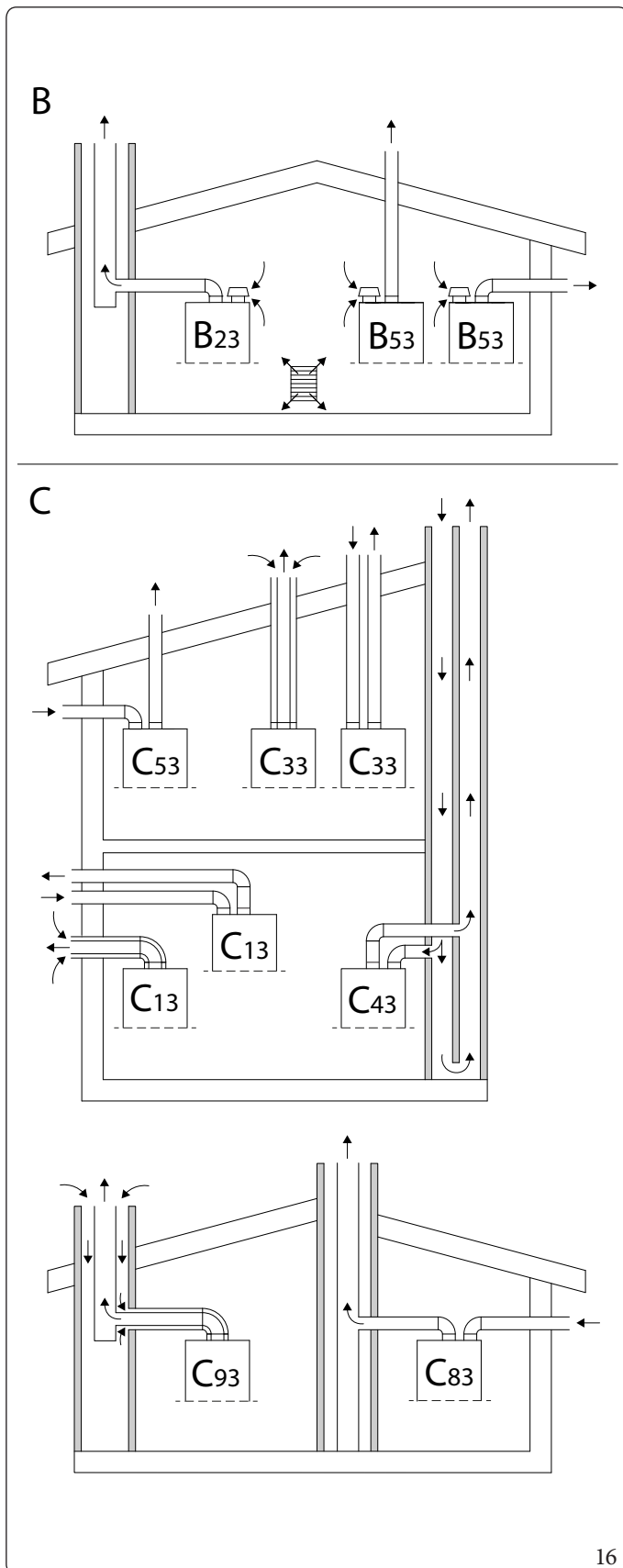

Installation types summarised table (Fig. 16):	
B	Appliance that withdraws air from the environment where it is installed and releases combustion products outside (either directly or through chimney or flue).
B ₂₃	An appliance without a draught stopper, which draws air from the room in which it is installed and discharges the combustion products through a chimney. The appliance is equipped with a fan upstream of the combustion circuit.
B ₅₃	An appliance without a draught stopper, which draws air from the room in which it is installed and discharges the combustion products through its own duct, to the outside (wall or roof). The appliance is equipped with a fan upstream of the combustion circuit.
C	Appliance whose combustion circuit (air feed, combustion chamber, heat exchanger and exhaust of combustion products) is sealed with respect to the room where the appliance is installed.
C ₁₃	Appliance with pipes connecting to a horizontal terminal, which simultaneously allows the inlet of combustion air and the release of flue gas through concentric orifices or close enough to be in similar wind conditions. The appliance is equipped with a fan upstream of the combustion circuit.
C ₃₃	Appliance with pipes connecting to a vertical terminal, which simultaneously allows the inlet of combustion air and the release of flue gas through concentric orifices or close enough to be in similar wind conditions. The appliance is equipped with a fan upstream of the combustion circuit.
C ₄₃	Appliance with two separate pipes connecting to a collective conventional flue. The flue consists of two pipes, concentric or separate, with air intake in one and flue gas release in the other and are in similar wind conditions. The appliance is equipped with a fan upstream of the combustion circuit.
C ₅₃	Appliance that withdraws air from outside and directly releases combustion products, through its ducts and terminals, outside (through wall or roof). These pipes can end up in different pressure zones. The appliance is equipped with a fan upstream of the combustion circuit.
C ₆	Type C appliance intended to be connected to an approved system and sold separately.
C ₈₃	Appliance connected, via its own exhaust duct, to a single chimney or to a collective natural draught flue. A second duct, an integral part of the appliance, is provided for the intake of combustion air from outside. The appliance is equipped with a fan upstream of the combustion circuit.
C ₉₃	Appliance connected via its ducted exhaust duct to a vertical terminal. The technical slot in which the exhaust is housed also acts as an intake duct for combustion air through the cavity. The appliance is equipped with a fan upstream of the combustion circuit.

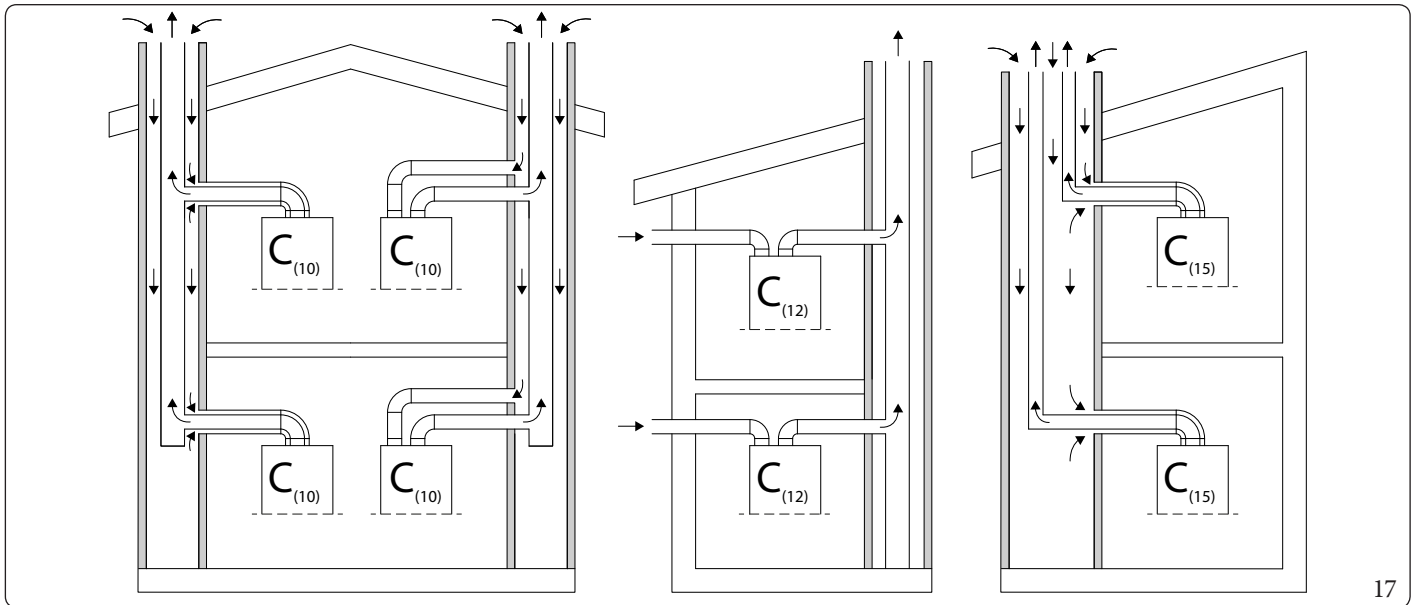

17

Installation types summarised table (Fig. 17):

C ₍₁₀₎	Appliance intended for connection, via its ducts, to a collective flue designed for more than one appliance. This flue consists of two ducts connected to a terminal, which simultaneously allows combustion air to enter and flue gas to be exhausted through orifices that are concentric or close enough to be in similar wind conditions. The appliance is equipped with a fan upstream of the combustion circuit.
C ₍₁₂₎	Appliance intended for connection, via its exhaust duct, to a collective flue designed for more than one appliance. A second duct, an integral part of the appliance, is provided for the intake of combustion air from outside. The appliance is equipped with a fan upstream of the combustion circuit.
C ₍₁₅₎	Appliance connected to a vertical flue exhaust terminal and a common vertical duct, designed for more than one appliance, for air intake. This duct simultaneously allows the inlet of combustion air and the release of flue gas through concentric orifices or close enough to be in similar wind conditions. The appliance is equipped with a fan upstream of the combustion circuit.

INSTALLER

USER

MAINTENANCE TECHNICIAN

TECHNICAL DATA

1.14 IMMERGAS FLUE SYSTEMS

Immergas supplies various solutions separately from the appliances regarding the installation of air intake and flue exhaust terminals, which are fundamental for appliance operation.

These solutions form an integral part of the product.



The appliance must be installed with an original Immergas "Green Range" inspectionable air intake system and flue gas extraction system made of plastic, with the exception of configuration C₆ in the configurations envisaged in Parag. 1.13, as required by the regulations in force and by the product's approval. This flue can be identified by an identification mark and special distinctive marking bearing the note "only for condensation boilers".

For non-original flue system, refer to the technical data of the appliance.



The plastic pipes cannot be installed outdoors, for tracts longer than 40 cm, without suitable protection from UV rays and other atmospheric agents.

Positioning the gaskets (black) for “green range” flue systems.

Position the gasket correctly (for bends and extensions) (Fig. 18):

- gasket (A) with notches, to use for bends;
- gasket (B) without notches, to use for extensions.

If necessary, to ease the push-fitting, spread the elements with commonly-used talc.

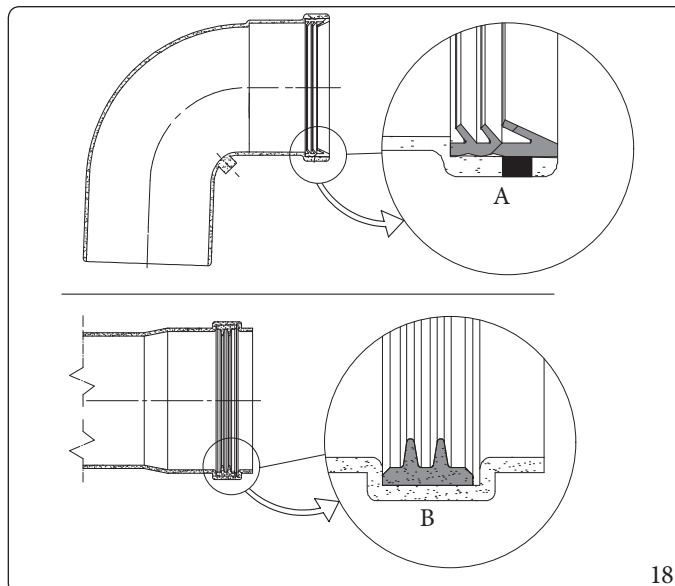

Extension pipes and concentric elbows push-fittings.

To install push-fitting extensions with other elements of the flue, proceed as follows:

- Install the concentric pipe or elbow with the male side (smooth) on the female side (with lip seal) to the end stop on the previously installed element in order to ensure sealing efficiency of the coupling.



If the exhaust terminal and/or extension concentric pipe needs shortening, consider that the internal duct must always protrude by 5 mm with respect to the external duct.









For safety purposes, do not even temporarily obstruct the appliance intake/exhaust terminal. The various parts of the flue system must be checked to ensure that they have been laid in such a way as to prevent the coupled parts from detaching, in particular, the flue exhaust duct in the Ø80 separator kit configuration. If the condition described above is not adequately guaranteed, it will be necessary to use the appropriate retaining clamp kit.

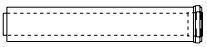

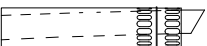
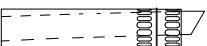
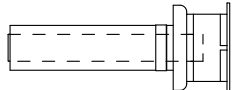
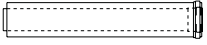
When installing horizontal pipes, a minimum inclination of 5% towards the appliance must be maintained, and a section clamp with plug must be installed every 3 metres.



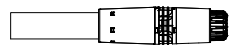



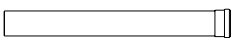

1.15 EQUIVALENT LENGTHS OF "GREEN RANGE" FLUE SYSTEM COMPONENTS.

Equivalent concentric lengths Ø 60/100 and Ø 80/125mm				
Duct Ø [mm]	Type of duct	picture	Equivalent length in [m] of concentric pipe	
			Ø 60/100mm	Ø 80/125mm
60/100	Concentric pipe Ø 60/100 m 1		1,00	-
	Ø 60/100 90° concentric elbow		1,30	-
	Concentric elbow 45° Ø 60/100		1,00	-
	Horizontal terminal Ø 60/100 concentric m 1 straight outlet		1,00	-
	Horizontal terminal Ø 60/100 concentric m 1 outlet 45°		2,50	-
	Horizontal terminal Ø 60/100 concentric m 1		1,00	-
	Vertical terminal Ø 60/100 concentric m 1.25		1,00	-
80/125	Concentric pipe 80/125 Ø m 1		-	1,00
	90° concentric bend 80/125 Ø		-	1,40
	Concentric bend 45° Ø 80/125		-	1,00
	Horizontal terminal Ø 80/125 concentric m 1		-	2,20
	Vertical terminal Ø 80/125 concentric m 1		-	1,70

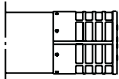

The values of the equivalent lengths in metres of concentric pipe of the Ø60/100 terminals are not the actual ones, but are weighted values to be used for the calculation of the flue.

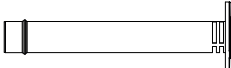
Equivalent lengths for split Ø 80mm









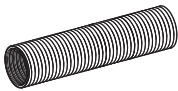
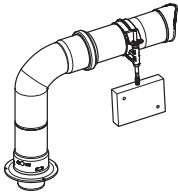

Duct Ø [mm]	Type of duct	Picture	Equivalent length in [m] of pipe Ø 80mm	
80/80	Pipe Ø 80 m 1		Exhaust	1,00
			Intake	0,70
	Ø 80 90° bend		Exhaust	2,10
			Intake	1,60
	Ø 80 45° bend		Exhaust	1,30
			Intake	1,00
	Horizontal terminal Ø 80 m 1		Exhaust	3,50
			Intake	2,50
	Horizontal terminal grid part Ø 80		Exhaust	2,50
			Intake	1,80
	Vertical exhaust terminal Ø 80		Exhaust	3,00
Vertical exhaust terminal Ø 80 stainless steel		Exhaust	3,00	
Intake stub pipe Ø 80		Intake	4,30	

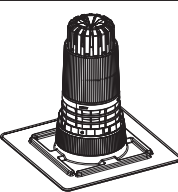
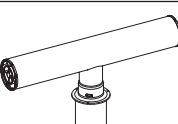
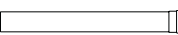







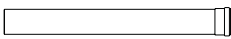

INSTALLER

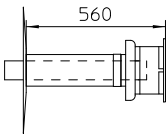
USER

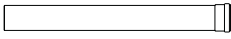
MAINTENANCE TECHNICIAN

TECHNICAL DATA

Equivalent lengths for Ø 50 mm flexible ducting				
Duct Ø [mm]	Type of duct	Picture	Equivalent length in [m] of Ø 50mm concentric hose	
50	Flexible hose Ø 50 m 1		Exhaust	1,00
	Terminal with 90° bend		Exhaust	1,20
	Flexible/rigid adapter (female/female)		Exhaust	0,35
	Support bend Ø 80 at 87°		Exhaust	0,60
	Vertical terminal Ø 80/125		Exhaust	0,50
	T-terminal Ø 80		Exhaust	1,00
80	Pipe Ø 80 m 1		Exhaust	0,15
			Intake	0,10
	Ø 80 90° bend		Exhaust	0,25
			Intake	0,20
Ø 80 45° bend		Exhaust	0,15	
		Intake	0,15	
80/125	Concentric pipe 80/125 Ø m 1		-	0,20
	90° concentric bend 80/125 Ø		-	0,30
	Concentric bend 45° Ø 80/125		-	0,20
60/100	Concentric pipe Ø 60/100 m 1		-	0,60
	Ø 60/100 90° concentric elbow		-	0,80
	Concentric elbow 45° Ø 60/100		-	0,60









Equivalent lengths for Ø 60 mm rigid ducting				
Duct Ø [mm]	Type of duct	Picture	Equivalent length in [m] of Ø 60mm pipe	
60	Pipe Ø 60 m 1 for ducting Ø 60 rigid		Exhaust	1,00
	Elbow 90° Ø 60 for ducting		Exhaust	1,10
	Elbow 45° Ø 60 for ducting		Exhaust	0,60
	Terminal complete with vertical exhaust Ø 60 for ducting		Exhaust	3,70
	Reduction Ø 80/60		Exhaust	0,80
80	Pipe Ø 80 m 1		Exhaust	0,40
			Intake	0,30
	Ø 80 90° bend		Exhaust	0,80
			Intake	0,60
	Ø 80 45° bend		Exhaust	0,50
			Intake	0,40
60/100	Concentric pipe Ø 60/100 m 1		-	2,00
	Ø 60/100 90° concentric elbow		-	2,50
	Concentric elbow 45° Ø 60/100		-	2,00

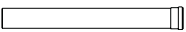

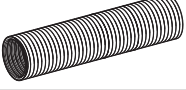
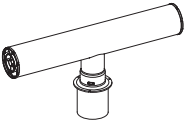

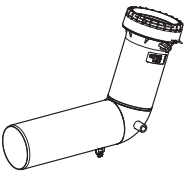
INSTALLER

USER

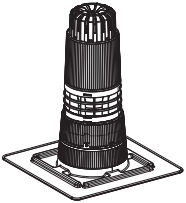
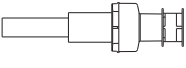
MAINTENANCE TECHNICIAN

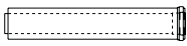
TECHNICAL DATA

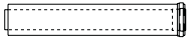
Equivalent lengths for Ø 80 mm rigid and Ø 80 mm flexible ducting					
Duct Ø [mm]	Type of duct	Picture	Equivalent length in [m] of pipe		
			-	Rigid Ø 80mm	Flexible Ø 80mm
80 rigid 80 flex	Pipe Ø 80 m 1		Exhaust	1,00	0,40
	Ø 80 90° bend		Intake	0,70	0,30
			Exhaust	2,00	0,80
	Ø 80 45° bend		Intake	1,50	0,60
			Exhaust	1,30	0,50
	Flexible hose Ø 80 (1 m)		Intake	1,00	0,40
			Exhaust	2,70	1,00
	T-terminal Ø 80		Exhaust	4,30	1,60
	Support bend Ø 80 to 87°		Exhaust	2,90	1,10
	Reduction Ø 80/60		Exhaust	2,10	0,80
	Support bend Ø 80 at 70°		Exhaust	2,70	1,00
	Male flexible adapter Ø 80		Exhaust	0,40	0,15
	Female flexible adapter Ø 80		Exhaust	0,60	0,20
	Flexible adapter/hose Ø 80		Exhaust	0,80	0,30
	Vertical terminal Ø 80 mm		Exhaust	1,90	0,70
Verticalexhaust terminal Ø 80		Exhaust	2,00	0,80	

Equivalent lengths for Ø 80 mm rigid and Ø 80 mm flexible ducting					
Duct Ø [mm]	Type of duct	Picture	Equivalent length in [m] of pipe		
			-	Rigid Ø 80mm	Flexible Ø 80mm
80/125	Concentric pipe 80/125 Ø m 1		-	1,80	0,70
	90° concentric bend 80/125 Ø		-	2,50	0,90
	Concentric bend 45° Ø 80/125		-	1,80	0,70
60/100	Concentric pipe Ø 60/100 m 1		-	2,50	1,30
	Ø 60/100 90° concentric elbow		-	3,50	2,00
	Concentric elbow 45° Ø 60/100		-	2,50	1,30

INSTALLER

USER

MAINTENANCE TECHNICIAN

TECHNICAL DATA

1.16 MAXIMUM FLUE LENGTH



The maximum flue length (L_{max}) is understood to include the terminal.



To calculate the equivalent length of the flue (L), simply add, for each component that you intend to use, the corresponding value indicated in the "Equivalent length in m of pipe" column of the table in par. 1.15, and check that the resulting sum is equal to or less than the maximum length (L_{max}) indicated in this paragraph ($L \leq L_{max}$).



Should L be higher than L_{max} , consider using another type of flue.

Type	Installation		VICTRIX MAIOR 35 PLUS
			L_{max} = Maximum length (m)
Ø 60/100mm	C ₁₃ (horizontal+elbow)		13
	C ₃₃ (vertical)		14,5
Ø 80/125mm	C ₁₃ (horizontal+elbow) C ₃₃ (vertical)		35
	C ₍₁₀₎₃ - C ₍₁₅₎₃		9
Ø 80/80mm	C ₄₃ - C ₅₃ - C ₈₃ (split)		35
	C ₍₁₀₎₃ - C ₍₁₂₎₃		10
	B ₂₃ - B _{23p} - B ₃₃ - B ₅₃ - B _{53p}		30
Ø 50 flexible	C ₅₃	Split duct 80/80 from boiler to connection in flue	13
Ø 60mm rigid			25
Ø 80mm rigid			35
Ø 80 flexible			30
Ø 50 flexible	C ₉₃ C ₍₁₅₎₃	Concentric 60/100 or 80/125 from boiler to flue	13
Ø 60mm rigid			25
Ø 80mm rigid			35
Ø 80 flexible			30

Note: Installation C₍₁₀₎ - C₍₁₂₎ type-approved with G20 gas only.



The values indicated in the table are the maximum available lengths.
Adjustment of the maximum boiler speed depending on the length of the actual pipes installed must refer to the Table in Par. 3.12.
The flue parameter (heat output) must be calibrated by the maintenance technician at initial testing.

Example of flue length calculation.

In the example of a concentric system (Fig. 19), the following dimensions must be added together to calculate the equivalent length of the flue (L):

1 m (Concentric pipe Ø 60/100) + 1,3 m (90° concentric elbow Ø 60/100) + 1 m (Concentric pipe Ø 60/100) + 1 m (45° concentric elbow Ø 60/100) + 1 m (45° concentric elbow Ø 60/100) + 1 m (Concentric terminal Ø 60/100).

$L = 1 + 1,3 + 1 + 1 + 1 + 1 = 6,3 \text{ m} \leq L_{\text{max}} = 13 \text{ m}$.

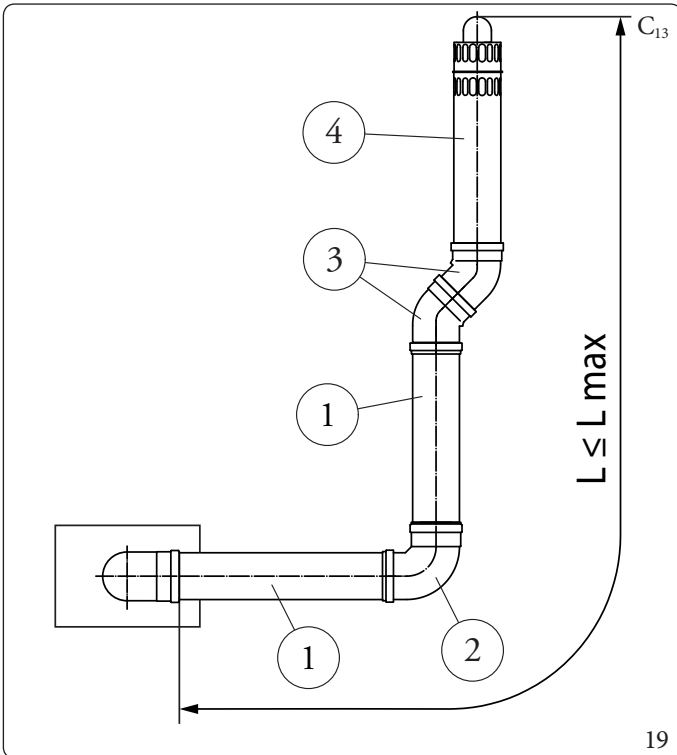

Key (Fig. 19):

- 1 - Concentric pipe Ø 60/100
- 2 - Ø 60/100 90° concentric elbow
- 3 - Concentric elbow 45° Ø 60/100
- 4 - Horizontal terminal complete with concentric intake-exhaust Ø 60/100
- L - Equivalent length
- L_{max} - Maximum length

INSTALLER

USER

i To calculate the flue length of other types of installations, follow the logic illustrated in this example.

MAINTENANCE TECHNICIAN

TECHNICAL DATA

1.17 OUTDOOR INSTALLATION IN PARTIALLY PROTECTED AREA



This appliance can be installed outdoors in a partially protected area.
By partially protected area, we mean one in which the unit is not directly exposed to the elements (rain, snow, hail, etc.).



If the appliance is installed in a location where the ambient temperature falls below -5°C , use the optional antifreeze kit, checking the ambient temperature range for operation in the technical data table in this instruction manual (Section 'Technical Data').



This type of installation is possible when permitted by the laws in force in the appliance's country of destination.

Configuration type B, open chamber and fan assisted (B₂₃ or B₅₃).

Using the relevant cover kit, direct air intake is possible and flue gas is exhausted into a single flue or directly to the outside. In this configuration it is possible to install the appliance in a partially protected place. In this configuration the appliance is classified as type B.

With this configuration:

- the flue gas exhaust must be connected to its own single chimney (B₂₃) or ducted directly outside via a vertical terminal for direct exhaust (B₅₃) or via an Immergas ducting system (B₅₃).

The technical regulations in force must be respected.

Cover kit assembly (Fig.20).

Remove the caps from the intake holes.

Install the discharge flange on the central hole of the boiler, positioning the relative gasket with the circular projections downwards in contact with the boiler flange, and tighten using the hex screws with flat tip contained in the kit.

Install the upper cover, fixing it using the 4 screws present in the kit, positioning the relevant gaskets.

Engage the 90° Ø 80 bend with the male end (smooth) in the female end (with lip seal) of the Ø 80 flange unit to the end stop. Introduce the gasket, making it run along the bend. Fix it using the metal sheet plate and tighten by means of the clips present in the kit, making sure to block the 4 gasket flaps.

Fit the male end (smooth) of the exhaust pipe into the female end of the 90° bend or Ø 80 extension, making sure that the relevant wall sealing plate is already fitted; this will ensure hold and joining of the elements making up the kit.

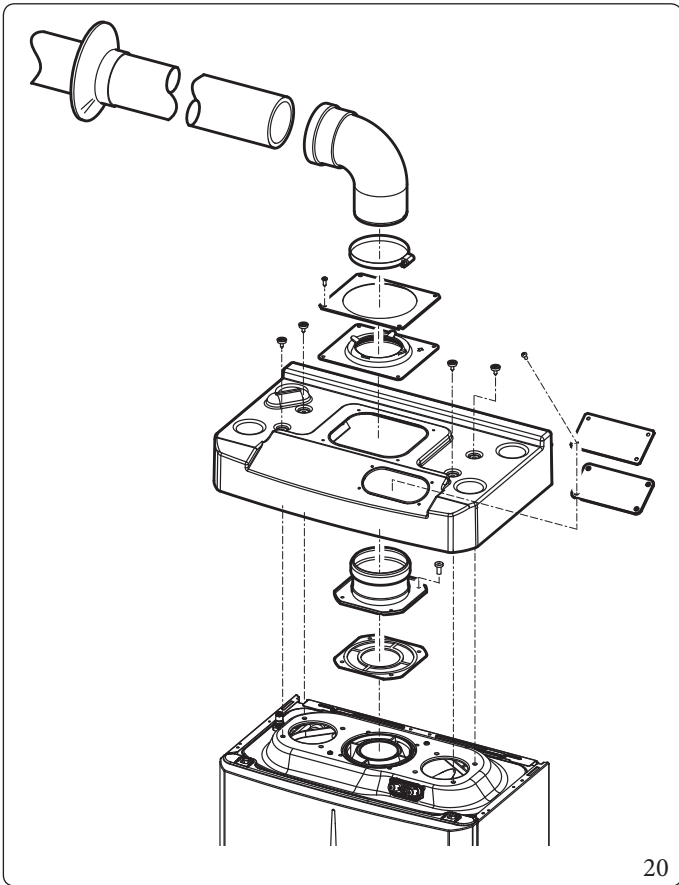

20

The cover kit includes (Fig. 20):

- N°1 Thermoformed cover
- N°1 Gasket clamping plate
- N°1 Gasket
- N°1 Gasket tightening clip
- N°1 Flange plate with sample points
- N°1 Sump flange plate gasket

The terminal kit includes (Fig. 20):

- N°1 Gasket
- N°1 Exhaust flange Ø80
- N°1 Ø80 90° bend
- N°1 Exhaust pipe Ø80
- N°1 Wall sealing plate

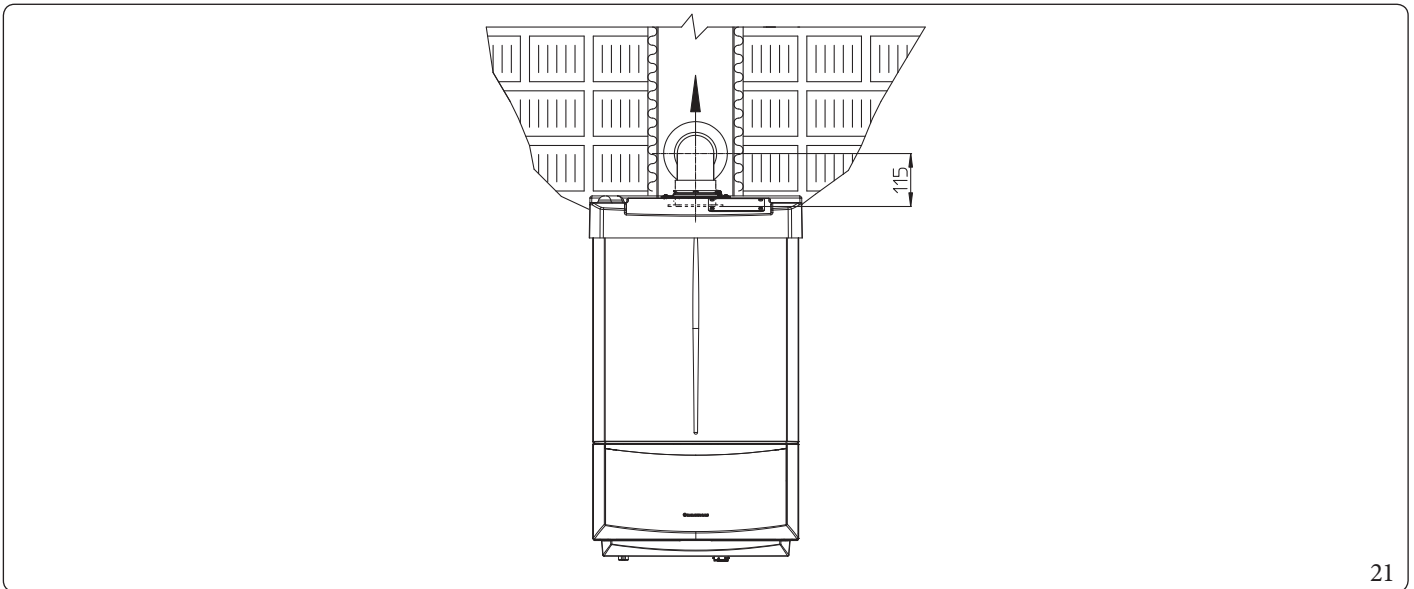

21

Coupling of extension pipes.

To install push-fitting extensions with other elements of the flue, proceed as follows: Couple the pipe or elbow with the male side (smooth) in the female side (with lip seal) to the end stop on the previously installed element. This will ensure sealing efficiency of the coupling.

Example of installation with direct vertical terminal in a partially protected place.

When using the vertical terminal for the direct combustion product exhaust, it is necessary to comply with the indications of UNI 7129-3 and in particular the minimum distance of 300 mm from a gutter or balcony above.

With installations under a balcony, the $X+Y+Z+W$ height evaluated with regard to the balcony above must be equal to or greater than 2000 mm (Fig. 22).

The term W must only be considered if the balcony above has completely closed balustrade ($W=0$ if the balustrade is open).

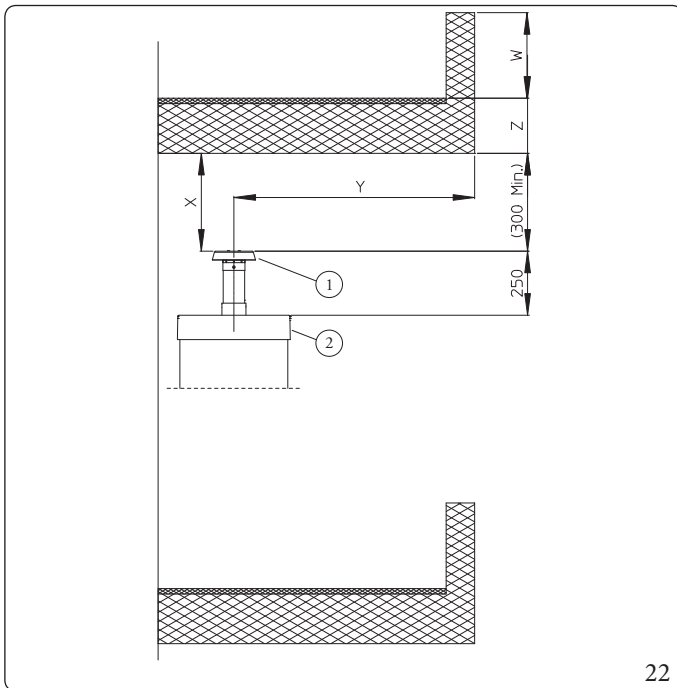

Key (Fig. 22):

- 1 - Vertical terminal kit for direct discharge
- 2 - Intake cover kit

Configuration without cover kit in a partially protected location (type C appliance).

By leaving the side plugs fitted, it is possible to install the appliance externally, in a partially covered place, without the cover kit.

Installation takes place using the $\varnothing 60/100$ and $\varnothing 80/125$ concentric intake/ exhaust kits. Refer to the paragraph on indoor installation.



The top cover kit, which provides additional protection for the boiler, CANNOT be used with $\varnothing 80/80$ separator configuration, $\varnothing 60/100$ concentric and $\varnothing 80/125$.

1.18 INTERNAL INSTALLATION USING A RECESSED FRAME WITH DIRECT AIR INTAKE

Configuration type B, open chamber and fan assisted

In this configuration the appliance is classified as type B₂₃.

Using a kit separator, one can achieve direct air intake (Fig. 23) and flue exhaust in a single chimney or directly outside.

With this configuration:

- air intake takes place directly from the environment in which the appliance is installed and only functions in permanently ventilated rooms;
- the flue gas exhaust must be connected to its own individual chimney and channelled directly into the external atmosphere.

The technical regulations in force must be respected.

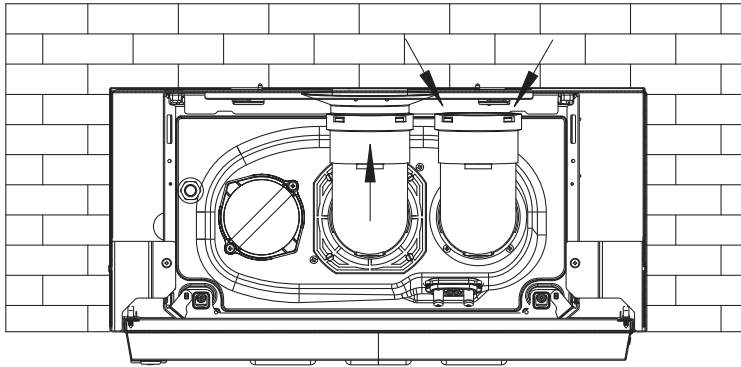

23

Separator kit installation (Fig. 24).

1. Install the discharge flange on the middle hole of the appliance, positioning the relative gasket with the circular projections downwards in contact with the appliance flange, and tighten using the hex screws with flat tip contained in the kit.
2. Remove the flat flange present in the lateral hole with respect to the central one (according to needs) and replace it with the intake flange, positioning its gasket and tighten using the supplied self-threading screws.
3. Fit the curves with the male side (smooth) into the female side of the flanges (the intake curve must face the rear side of appliance).
4. Fit the exhaust pipe with the male side (smooth) to the female side of the bend up to the end stop, making sure that the internal wall sealing plate has been fitted and connecting the required flue according to personal requirements.

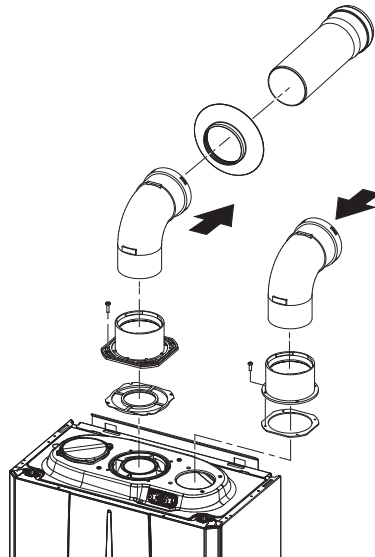

24

In case of installation C₍₁₀₎/C₍₁₂₎ the flue gas non-return valve must be installed and ONLY the vertical outlet can be installed in the recessed frame.

1.19 CONCENTRIC HORIZONTAL KIT INSTALLATION

Type C configuration, sealed chamber and fan assisted

The position of the terminal (in terms of distances from openings, overlooking buildings, floor, etc.) must be in compliance with the regulations in force.

This terminal is connected directly to the outside of the building for air intake and flue gas exhaust.

The horizontal kit can be installed with the rear, right side, left side or front outlet.

For installation with frontal outlet, one must use the fixing plate and a concentric bend coupling in order to ensure sufficient space to carry out the tests required by law upon commissioning.

External grid

Make sure that the external silicone wall sealing plate is properly inserted in the wall.



For correct functioning of the system the terminal with grid must be installed correctly ensuring that, the "high" indication present on the terminal is respected on installation.

Horizontal intake/exhaust assembly kits Ø 60/100 (Fig. 25)

1. Install the curve with flange (2) on the central hole of the appliance, positioning gasket (1) with the circular projections downwards in contact with the appliance flange, and tighten using the screws contained in the kit.
2. Fit the Ø 60/100 (3) concentric terminal pipe with the male side (smooth) to the female side of the bend (2) up to the end stop, making sure that the internal and external wall sealing plates have been fitted; this will ensure sealing and joining of the elements making up the kit.

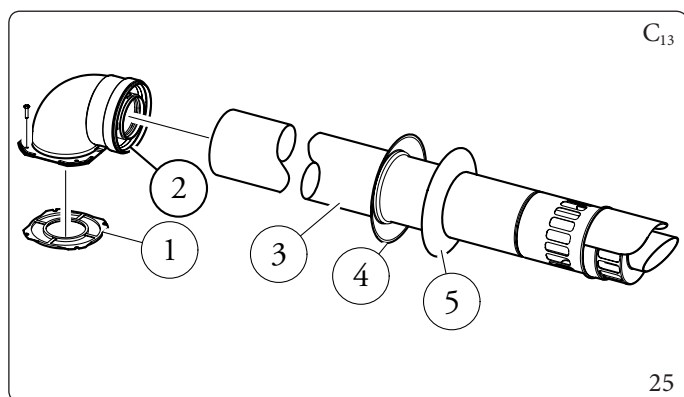

The kit includes (Fig. 25):

- N°1 Gasket (1)
- N°1 Concentric bend Ø60/100 (2)
- N°1 Int./exhaust concentric terminal Ø60/100 (3)
- N°1 Internal wall sealing plate (4)
- N°1 External wall sealing plate (5)

Extensions for Ø 60/100 horizontal kit (L = Equivalent length - L max = Maximum length) (Fig. 26).

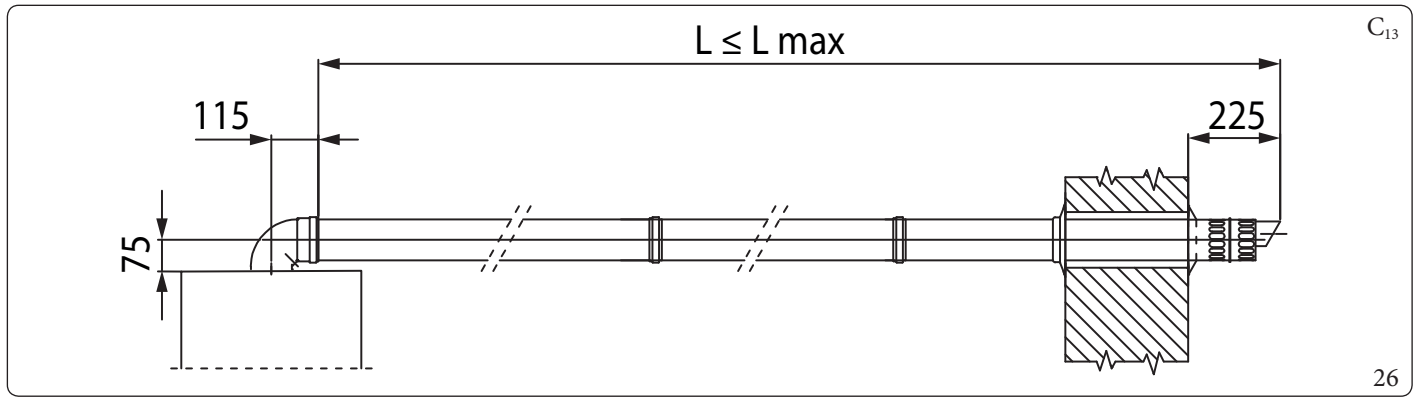

i The maximum lengths ((L.max) of the various flues that can be installed are given in the summary table in parag. 1.16.

Installation examples

Type of Duct	Minimum outlet height roof/wall (m)
	X
Concentric Ø 60/100 Horizontal	0,225

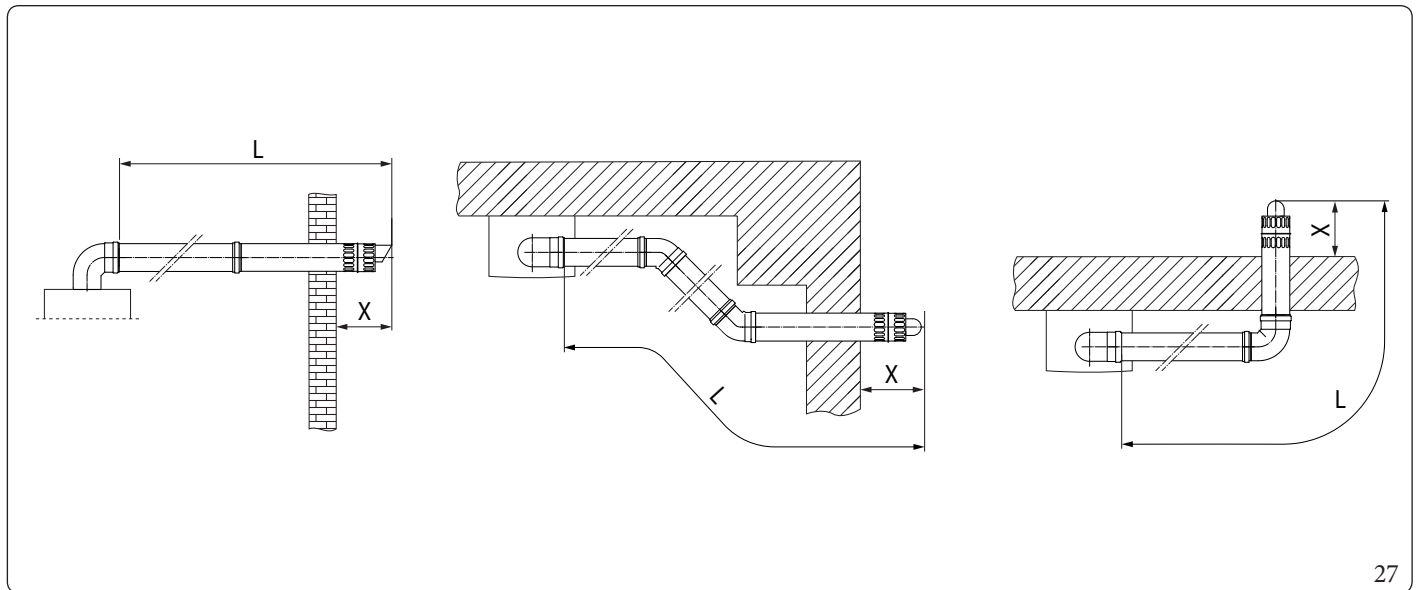

i To calculate the equivalent length of the flue (L), simply add, for each component you intend to use, the corresponding value indicated in the column "Length equivalent to m of pipe" in the table in par. 1.15, and check that the resulting sum is equal to or less than the maximum length (L max) indicated in par. 1.16. ($L \leq L \text{ max}$).

INSTALLER

USER

MAINTENANCE TECHNICIAN

TECHNICAL DATA

Horizontal intake/exhaust assembly kits Ø 80/125 (Fig. 28)

To install the kit Ø 80/125 one must use the flanged adapter kit (pos. 2, Fig. 28).

1. Install the flanged adaptor (2) on the central hole of the appliance, positioning gasket (1) with the circular projections downwards in contact with the appliance flange, and tighten using the screws contained in the kit.
2. Engage the bend (3) with the male side (smooth) to the end stop on the adapter (2).
3. Fit the Ø 80/125 (4) concentric terminal pipe with the male side (smooth) to the female side of the bend (3) (with lip seals) up to the end stop, making sure that the internal (5) and external wall sealing plates (6) have been fitted; this will ensure sealing and joining of the elements making up the kit.

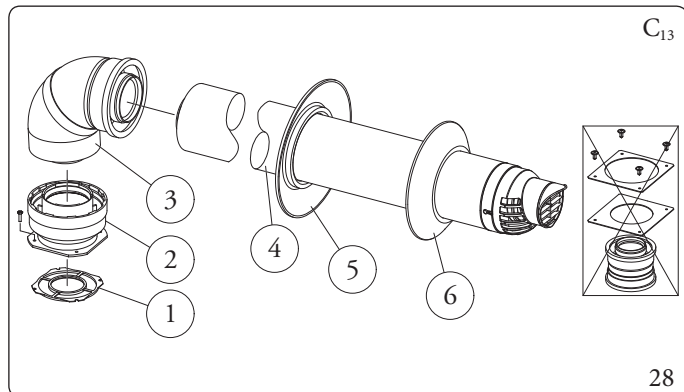

The adapter kit includes (Fig. 28):

- N°1 Gasket (1)
- N°1 Adapter Ø 80/125 (2)

The Ø 80/125 kit includes (Fig. 28):

- N°1 Concentric bend Ø 80/125 at 87° (3)
- N°1 Int./exhaust concentric terminal Ø 80/125 (4)
- N°1 Internal wall sealing plate (5)
- N°1 External wall sealing plate (6)

The remaining kit components must not be used

Extensions for Ø 80/125 horizontal kit ($L =$ Equivalent length - $L_{max} =$ Maximum length) (Fig. 29).

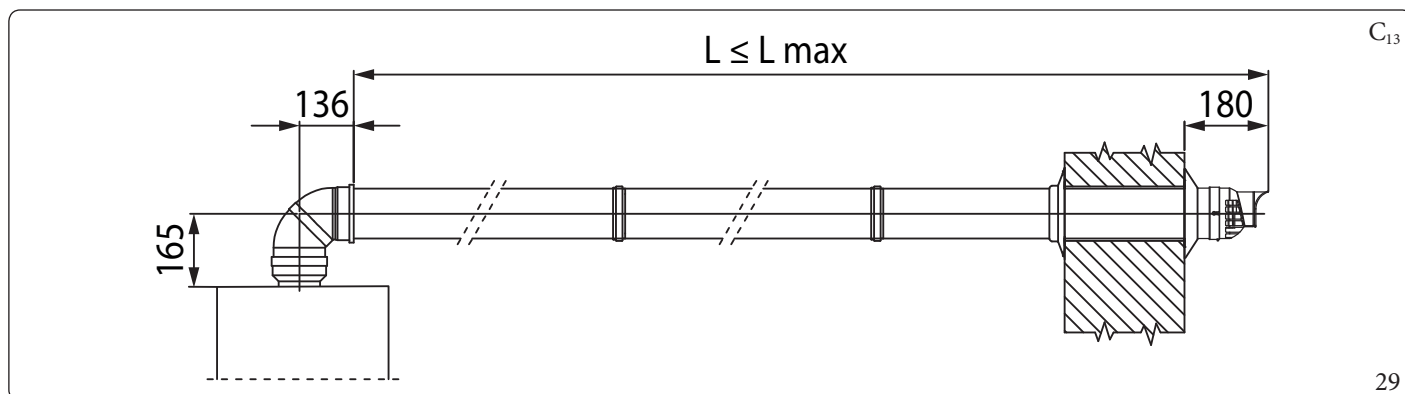

The maximum lengths (L_{max}) of the various flues that can be installed are given in the summary table in parag. 1.16.

Installation examples

Type of Duct	Minimum outlet height roof/wall (m)
	X
Concentric Ø 80/125 Horizontal	0,18

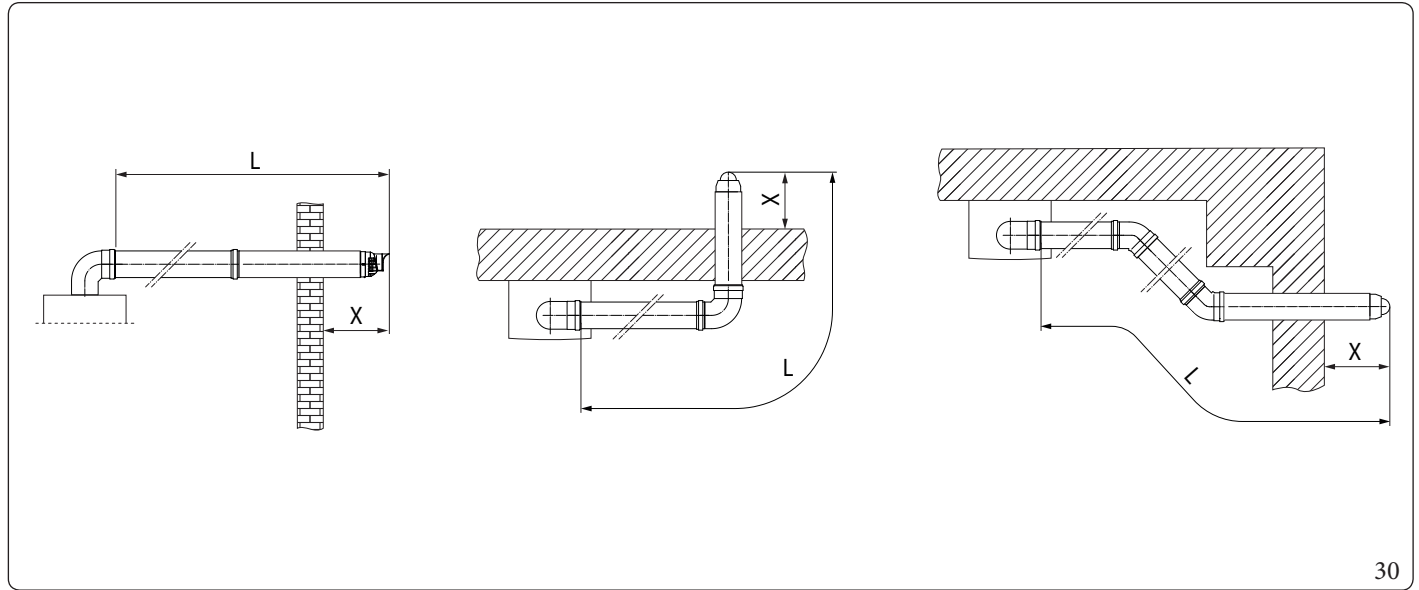

To calculate the equivalent length of the flue (L), simply add, for each component you intend to use, the corresponding value indicated in the column "Length equivalent to m of pipe" in the table in par. 1.15, and check that the resulting sum is equal to or less than the maximum length (L max) indicated in par. 1.16. ($L \leq L_{max}$).

INSTALLER

USER

MAINTENANCE TECHNICIAN

TECHNICAL DATA

1.20 CONCENTRIC VERTICAL KIT INSTALLATION

Type C configuration, sealed chamber and fan assisted

Concentric vertical intake and exhaust kit.

This vertical terminal is connected directly to the outside of the building for air intake and flue gas exhaust.



The vertical kit with aluminium slate enables installation on terraces and roofs with a maximum slope of 45% (approx 25°) and the height between the terminal cap and half-shell (374 mm for Ø 60/100 and 260 mm for Ø 80/125) must always be observed.

Vertical kit assembly with aluminium slate Ø60/100 (Fig. 31)

1. Install the concentric flange (2) on the flue exhaust of the appliance, positioning gasket (1) with the circular projections downwards in contact with the appliance flange.
2. Tighten the concentric flange with the screws in the kit.

Imitation aluminium slate installation:

3. Replace the slates with the aluminium sheet (4), shaping it to ensure that rainwater runs off.
4. Position the fixed half-shell (6) on the aluminium slate.
5. Insert the intake-exhaust pipe (5).
6. Fit the Ø 60/100 concentric terminal pipe with the male side (5) (smooth) into the flange (2) up to the end stop, making sure that the wall sealing plate has been fitted (3); this will ensure sealing and joining of the elements making up the kit.



When the appliance is installed in areas where very rigid temperatures can be reached, a special anti-freeze kit is available that can be installed as an alternative to the standard kit.

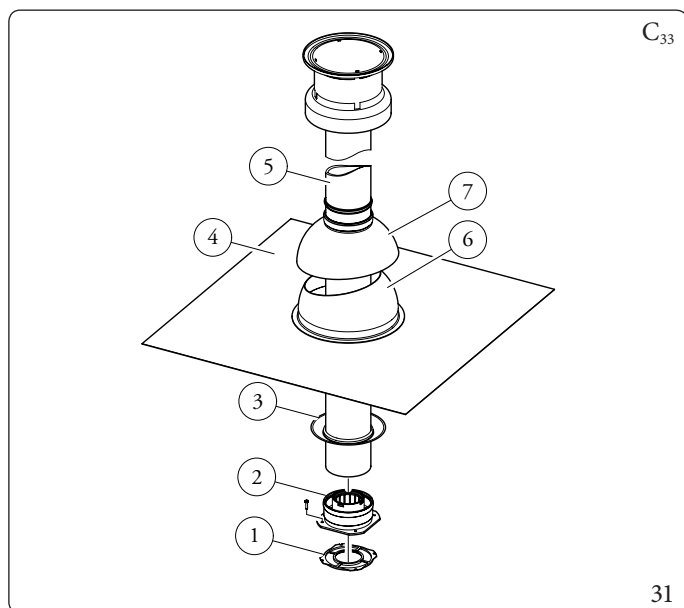

The kit includes (Fig. 31):

- N°1 Gasket (1)
- N°1 Female concentric flange (2)
- N°1 Wall sealing plate (3)
- N°1 Aluminium slate (4)
- N°1 Concentric intake/exhaust pipe Ø 60/100 (5)
- N°1 Fixed half-shell (6)
- N°1 Mobile half-shell (7)

Extensions for vertical kit Ø 60/100 (L = Equivalent length - L max = Maximum length) (Fig. 32).



The maximum lengths ((L max) of the various flues that can be installed are given in the summary table in parag. 1.16.

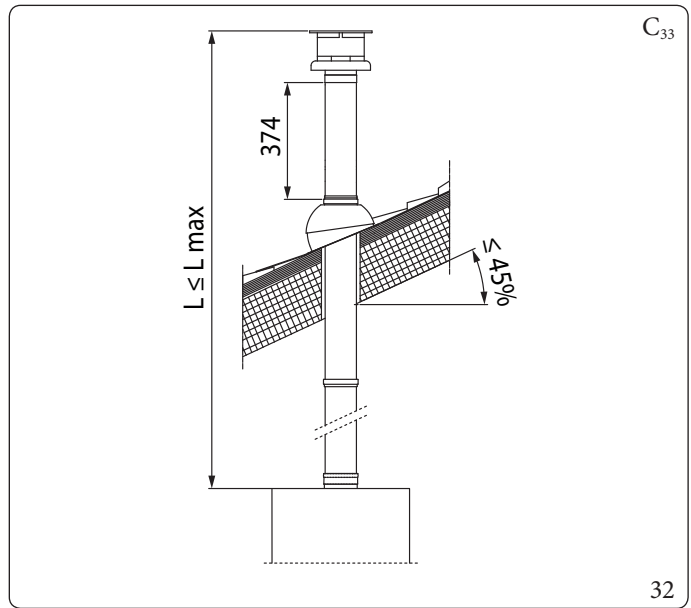

INSTALLER

USER

MAINTENANCE TECHNICIAN

TECHNICAL DATA

Installation examples

Type of Duct	Minimum outlet height roof/wall (m)
	X
Concentric Ø 60/100 Vertical	0,374

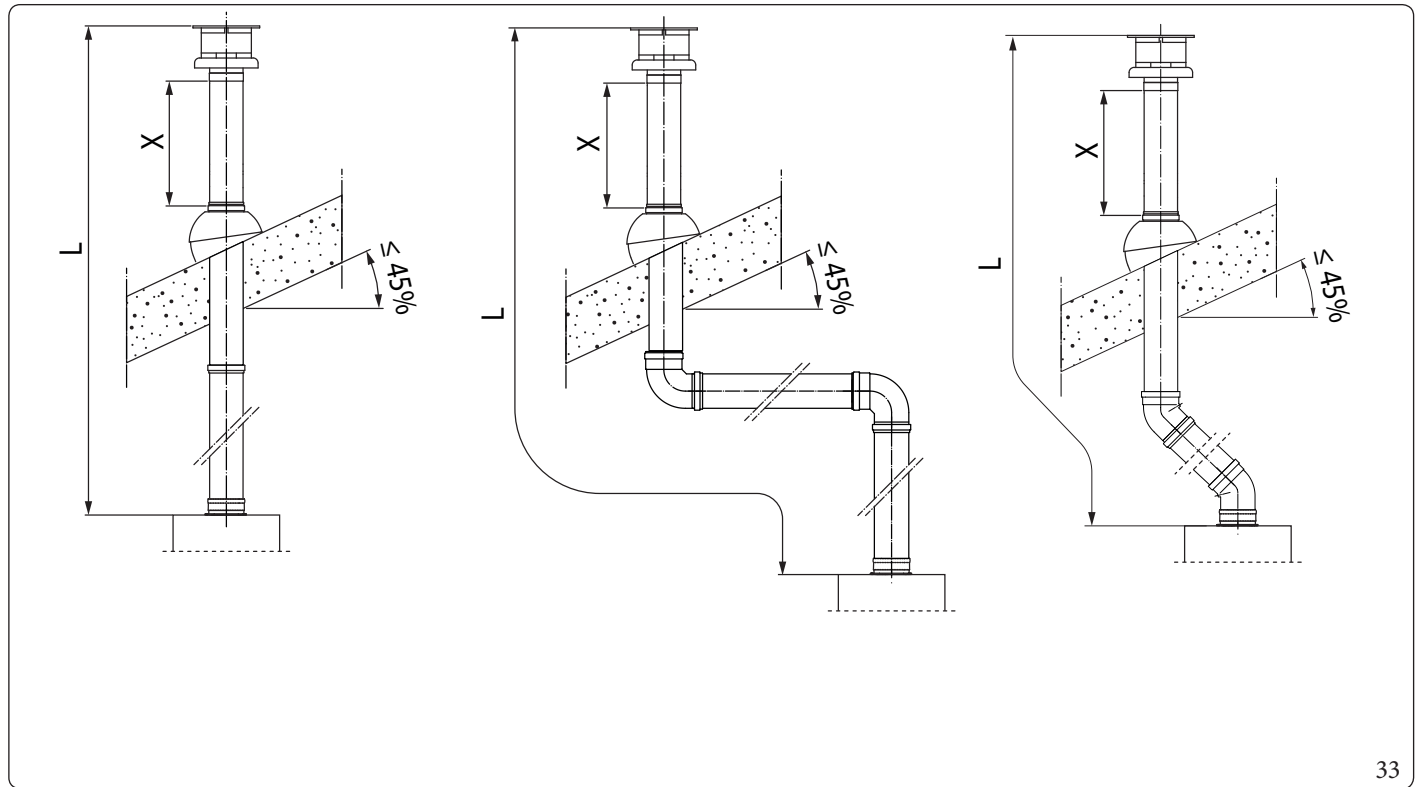

To calculate the equivalent length of the flue (L), simply add, for each component you intend to use, the corresponding value indicated in the column "Length equivalent to m of pipe" in the table in par. 1.15, and check that the resulting sum is equal to or less than the maximum length (L max) indicated in par. 1.16. ($L \leq L_{max}$).

Vertical kit assembly with aluminium slate Ø80/125 (Fig. 34)



To install the kit Ø 80/125 one must use the adapter kit (pos. 2, Fig. 34).

1. Install the concentric flange (2) on the flue exhaust of the appliance, positioning gasket (1) with the circular projections downwards in contact with the appliance flange.

Imitation aluminium slate installation:

2. Tighten the concentric flange with the screws in the kit.
3. Replace the slates with the aluminium sheet (4), shaping it to ensure that rainwater runs off.
4. Position the fixed half-shell (5) on the aluminium slate;
5. Insert the intake-exhaust terminal (7);
6. Fit the Ø 80/125 concentric terminal pipe with the male side (smooth) to the female side of the adapter (1) (with lip seals) up to the end stop, making sure that the wall sealing plate (3) has been fitted; this will ensure sealing and joining of the elements making up the kit.

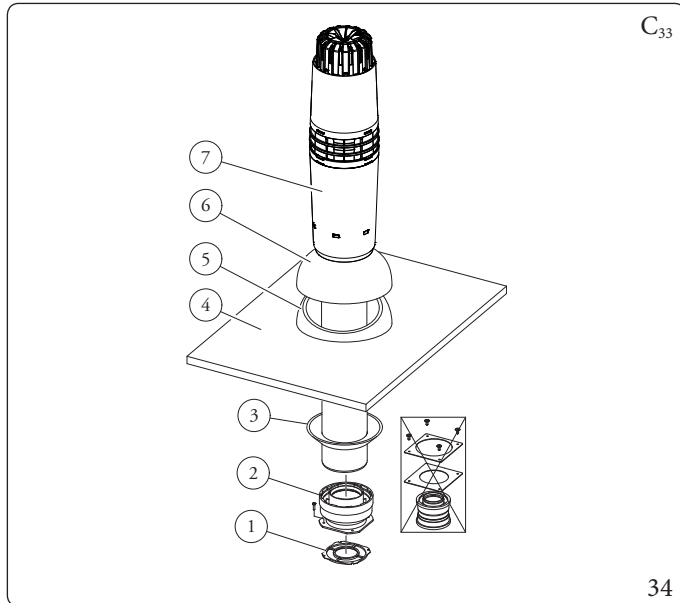

The adaptor kit includes (Fig. 34):

- N°1 Gasket (1)
- N°1 Adapter Ø 80/125 (2)

The Ø 80/125 kit includes (Fig. 34):

- N°1 Wall sealing plate (3)
 - N°1 Aluminium slate (4)
 - N°1 Fixed half-shell (5)
 - N°1 Mobile half-shell (6)
 - N°1 Concentric intake/exhaust pipe Ø 80/125 (7)
- The remaining kit components must not be used

Extensions for vertical kit Ø 80/125 (L = Equivalent length - L max = Maximum length) (Fig. 35).



The maximum lengths ((L max) of the various flues that can be installed are given in the summary table in parag. 1.16.

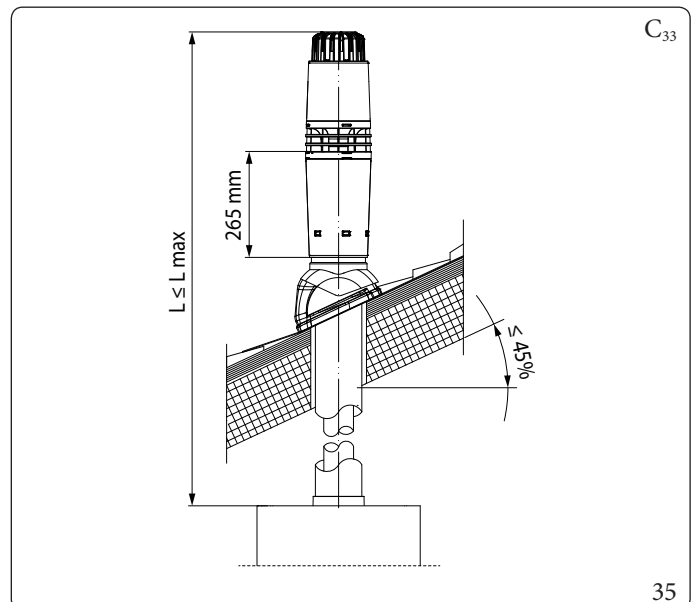

Installation examples

Type of Duct	Minimum outlet height roof/wall (m)
	X
Concentric Ø 80/125 Vertical	0,26

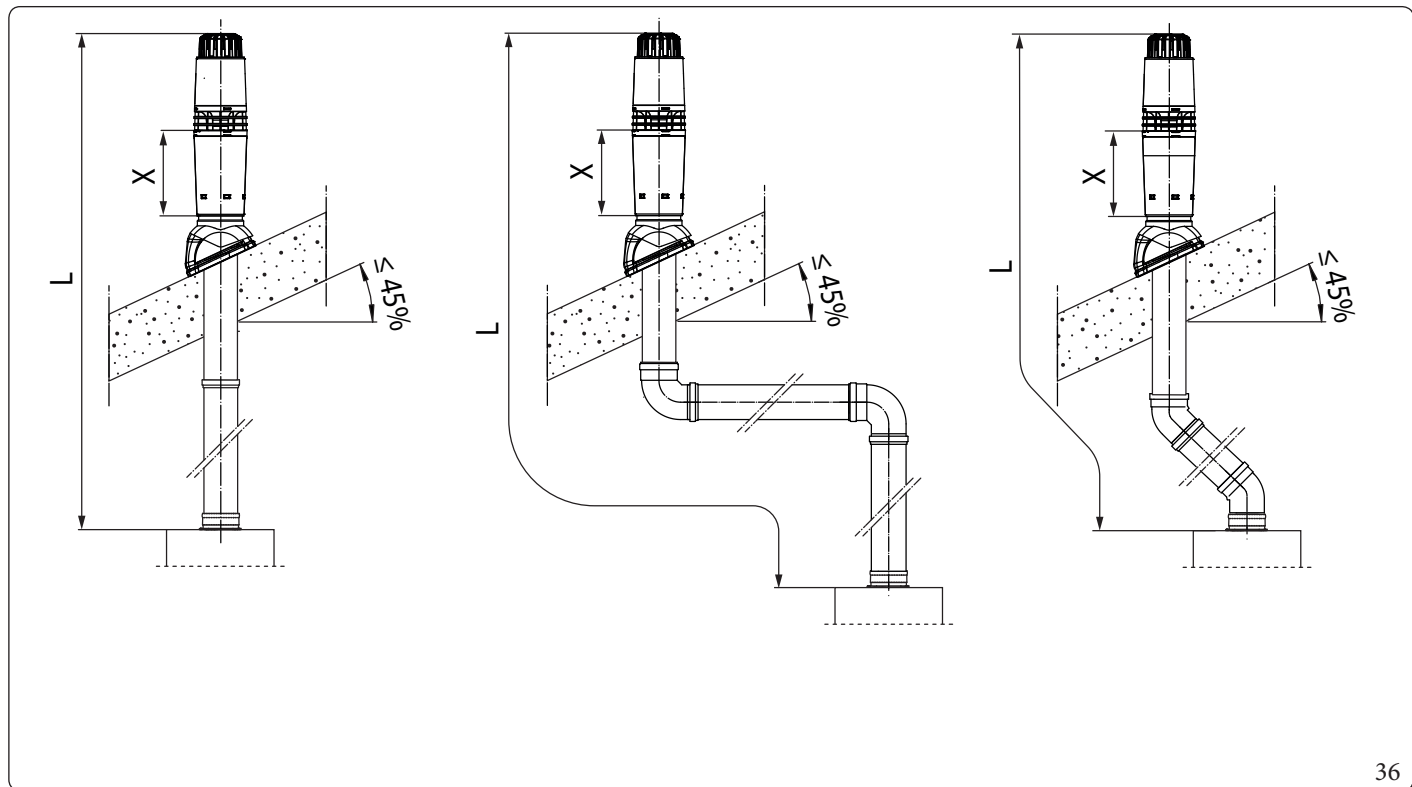

To calculate the equivalent length of the flue (L), simply add, for each component you intend to use, the corresponding value indicated in the column "Length equivalent to m of pipe" in the table in par. 1.15, and check that the resulting sum is equal to or less than the maximum length (L max) indicated in par. 1.16. ($L \leq L_{max}$).

1.21 SEPARATOR KIT INSTALLATION

Type C configuration, sealed chamber and fan assisted separator kit Ø 80/80

This kit allows air to come in from outside the building and the exhaust to exit from the chimney, flue or intubated duct through divided flue exhaust and air intake pipes.

Combustion products are expelled from pipe (S) (in plastic, so as to resist acid condensate).

Air is taken in through duct (A) for combustion (this is also in plastic).

Both ducts can be routed in any direction.

Assembly of separator kit Ø 80/80 (Fig. 37):

1. Install the flange (4) on the central hole of the appliance, positioning gasket (1) with the circular projections downwards in contact with the appliance flange.
2. Tighten with the hexagonal head and flat point screws provided in the kit.
3. Replace the flat flange present in the lateral hole with respect to the central one (according to needs) with the flange (3), positioning the gasket (2) in between.
4. Tighten with the supplied self-tapping screws with drill bit.
5. Fit the bends with male side (smooth) (5) in the female side of the flanges (3 and 4).
6. Fit the intake terminal (6) with the male side (smooth) in the female side of the bend (5) up to the end stop, ensuring that the internal and external wall sealing plates are fitted
7. Fit the exhaust pipe (9) with the male end (smooth) to the female end of the bend (5) up to the end stop; making sure that the internal wall sealing plate has been fitted, this will ensure sealing and joining of the elements making up the kit.

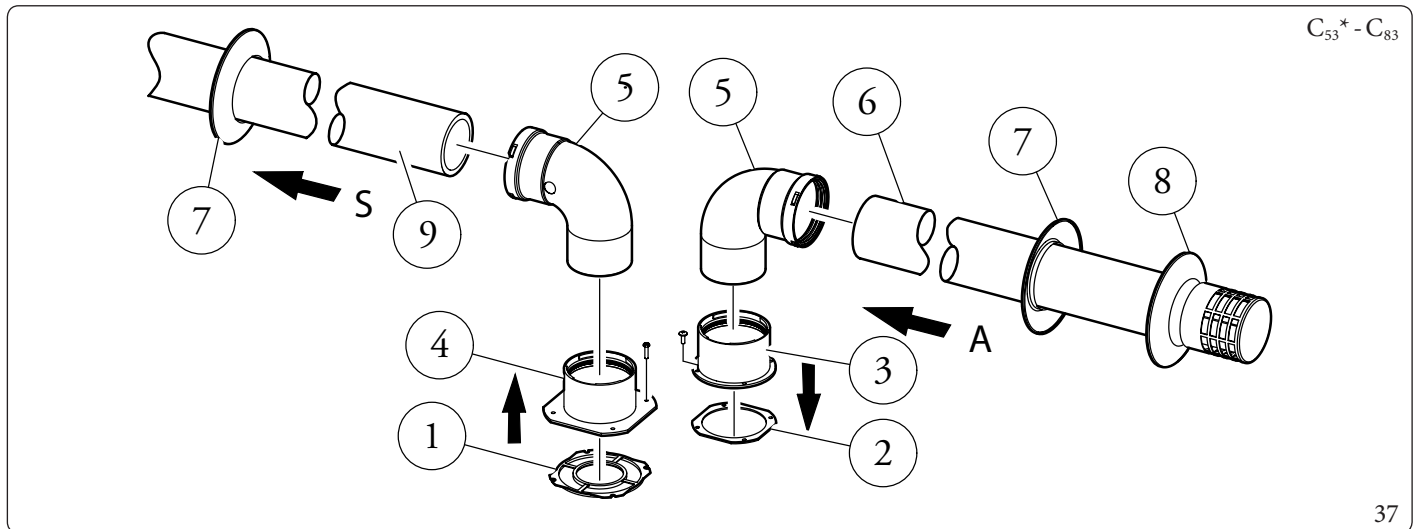

The kit includes (Fig. 37):

- N°1 Exhaust gasket (1)
- N°1 Flange gasket (2)
- N°1 Female intake flange (3)
- N°1 Female exhaust flange (4)
- N°2 Ø80 90° bend (5)
- N°1 Intake terminal Ø80 (6)

N°2 Internal wall sealing plates (7)

N°1 External wall sealing plate (8)

N°1 Exhaust pipe Ø80 (9)

* to complete C₅₃ configuration, also provide for a "green range" roof discharge terminal. The configuration on walls opposite the building is not allowed.

Installation clearances (Fig. 38)

The minimum installation clearance measurements of the Ø 80/80 separator terminal kit have been stated in some limit conditions.

* Configuration C₄ envisages connection to flues working with natural draught.



For technical data concerning configuration C₄ please refer to the table in par. 4.3.

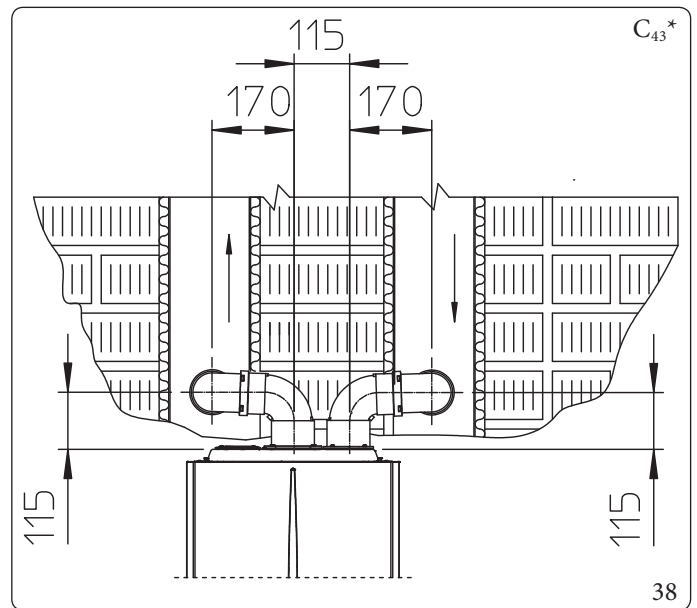

Extensions for separator kit Ø 80/80 (L = Length - L max = Maximum length)



To aid in the removal of possible condensate forming in the exhaust pipe, tilt the pipes towards the appliance with a minimum slope of 5% (Fig. 39).

Please note the type of installation C₄₃ must be done with a natural draught flue.

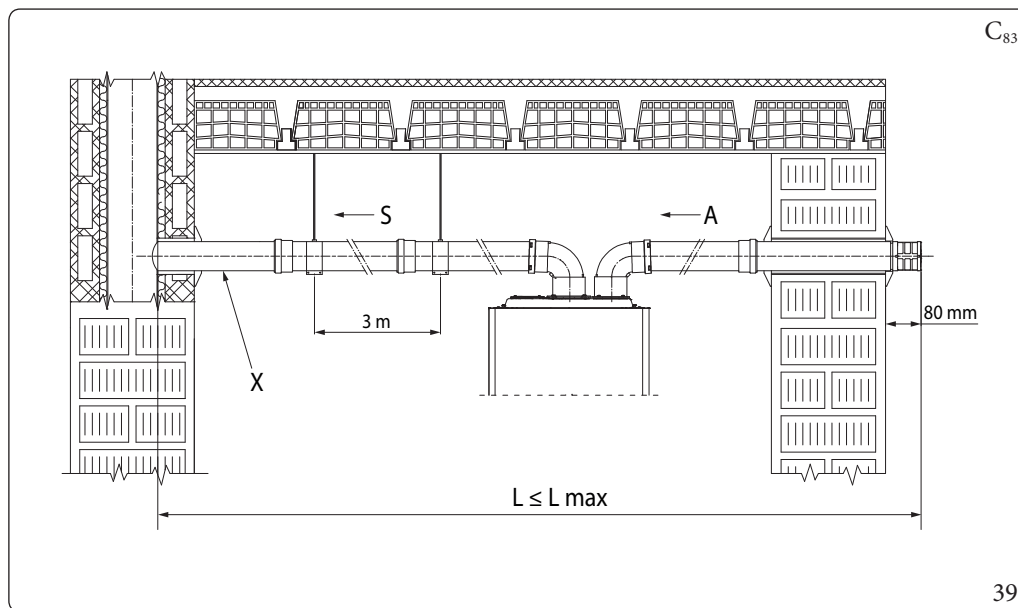

Key (Fig. 39):

- A - Intake
- X - Minimum slope 5%
- S - Exhaust
- L - Equivalent length
- L max - Maximum length



The maximum lengths ((L max) of the various flues that can be installed are given in the summary table in parag. 1.16.

Installation examples

Type of Duct	Minimum outlet height roof/wall (m)
	X
Split Ø 80/80 Horizontal (with intake and exhaust bend)	0,08
Split Ø 80/80 Vertical (without bends)	-

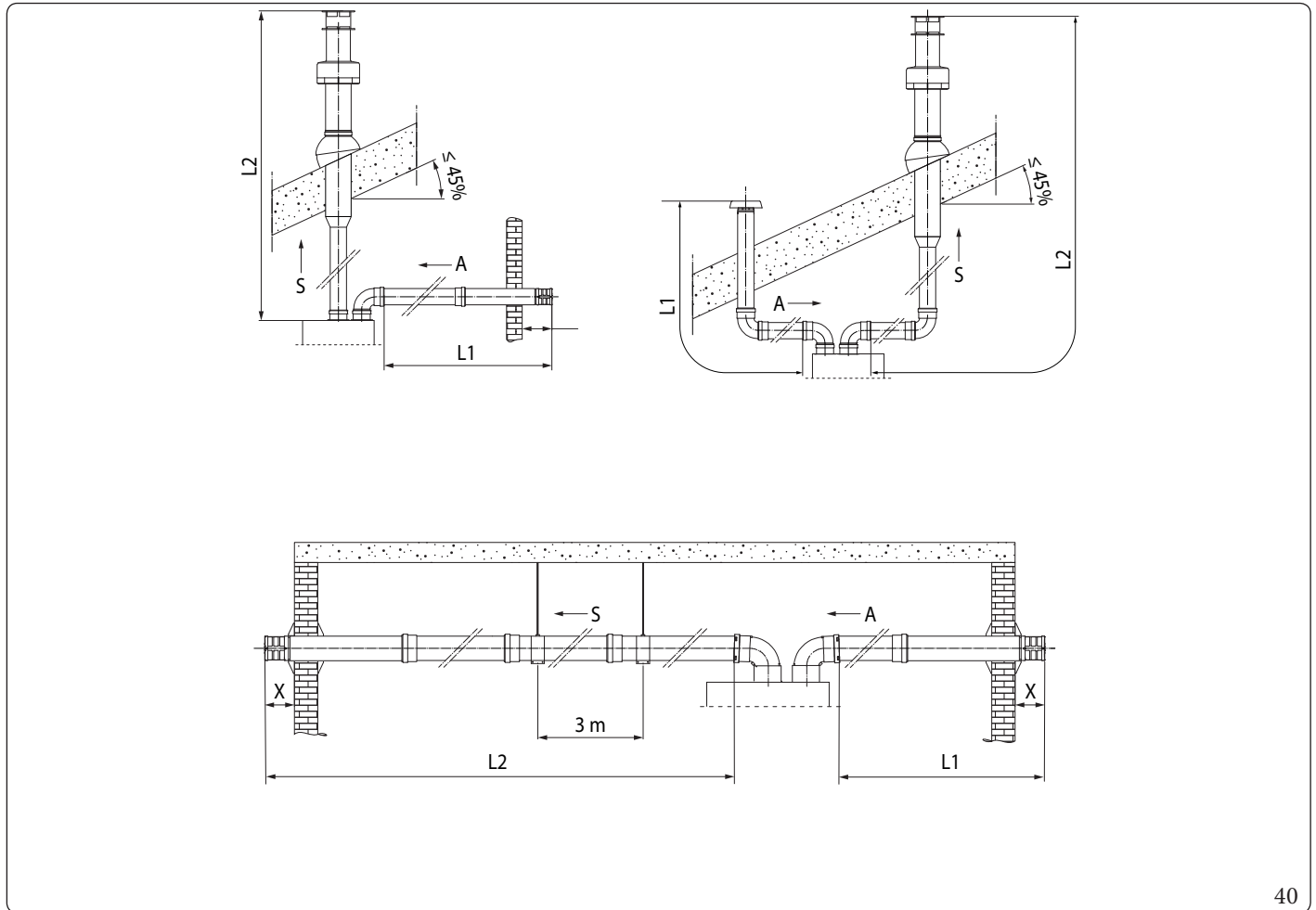

40



To calculate the equivalent length of the flue (L), simply add, for each component you intend to use, the corresponding value indicated in the column "Length equivalent to m of pipe" in the table in par. 1.15, and check that the resulting sum is equal to or less than the maximum length (L max) indicated in par. 1.16. ($L \leq L_{max}$).

INSTALLER

USER

MAINTENANCE TECHNICIAN

TECHNICAL DATA

1.22 ADAPTOR KIT INSTALLATION C₉

This kit allows an Immergas appliance to be installed in C₉₃ configuration, with combustion air intake directly from the shaft where the flue gas exhaust is, obtained by means of a ducting system.

System composition

The system must be combined with the following components (sold separately) to be functional and complete:

- kit C₉₃ " Ø 100 or Ø 125 version;
- ducting kit rigid Ø 60 and Ø 80 and flexible Ø 50 and Ø 80;
- flue exhaust kit Ø 60/100 or Ø 80/125 configured according to the installation and type of appliance.

Mounting adapter kit C₉ (Fig. 41)



(Version Ø 125 only) before assembly check the gaskets are in the right position.

In the event component lubrication (already carried out by the manufacturer) is not sufficient, remove the residual lubricant using a dry cloth, then to ease fitting coat the parts with common or industrial talc.



To aid in the removal of possible condensate forming in the exhaust pipe, tilt the pipes towards the appliance with a minimum slope of 5% (Fig. 39).

1. Mount the components of kit C₉ on the door (A) of the ducting system (Fig.41).
2. (Version Ø 125 only) mount the flanged adaptor (11) interposing the concentric gasket (10) on the appliance, fitting it with the screws (12).
3. Mount the ducting system as described in the relative instructions sheet.
4. Calculate the distances between the appliance drain and the bend of the ducting system.
5. Prepare the appliance flue system, making sure that the internal pipe of the concentric kit is fitted up to the end stop in the ducting system curve (Quota "X" Fig. 43), whereas the external pipe must reach the end stop of the adapter (1).
6. Mount the cover (A) complete with adaptor (1) and caps (6) on the wall.
7. Assemble the flue system to the ducting system.

Once all components have been assembled properly, the exhaust fumes will be expelled via the ducting system; the combustion air for normal boiler operation will be aspirated directly by the shaft (Fig. 43).

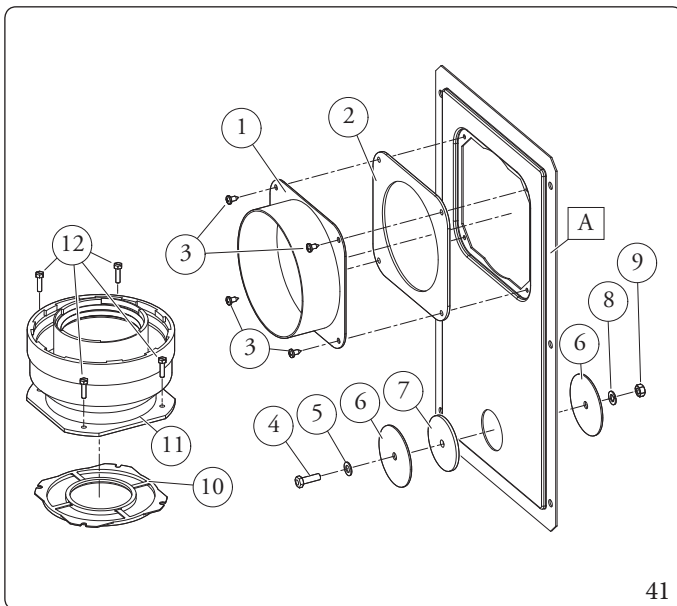

The adapter kit includes (Fig. 41):

- N°1 Door adaptor Ø 100 or Ø 125 (1)
- N°1 Door gasket made of neoprene (2)
- N°4 Screws 4.2x9 AF (3)
- N°1 Hex headed screw M6x20 (4)
- N°1 Flat nylon washer M6 (5)
- N°2 Door hole closure metal-sheet plate plug (6)
- N°1 Plug gasket made of neoprene (7)
- N°1 Toothed washer M6 (8)
- N°1 Nut M6 (9)
- N°1 (Ø 80/125 kit) Concentric gasket Ø 60/100 (10)
- N°1 (Ø 80/125 kit) Flanged adaptor Ø 80/125 (11)
- N°4 (Ø 80/125 kit) M4 hex headed screws x 16 slotted screwdriver (12)
- N°1 (Ø 80/125 kit) Bag of lubricating talc

Supplied separately (Fig. 41):

- N°1 Ducting kit door (A)

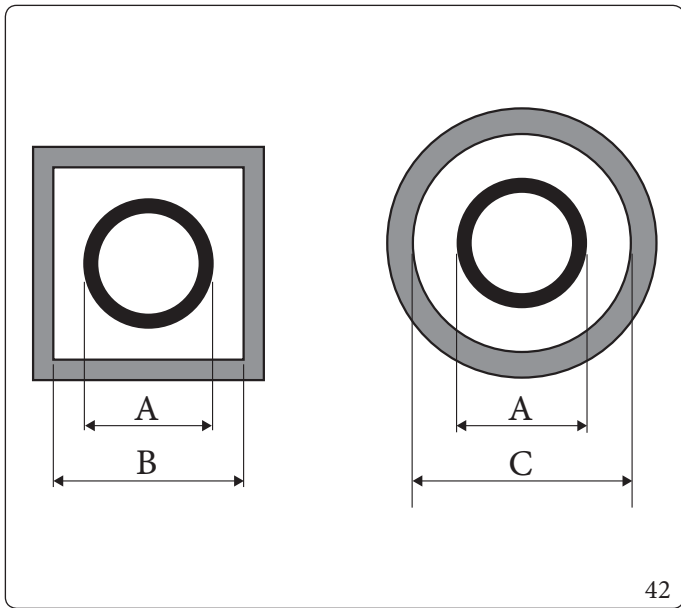

Ducting	ADAPTOR (A) mm	SHAFT (B) mm	SHAFT (C) mm
Ø60 Rigid	66	106	126
Ø50 Flexible	66	106	126
Ø80 Rigid	86	126	146
Ø80 Flexible	103	143	163

Technical data

The dimensions of the shafts must ensure a minimum gap between the outer wall of the smoke duct and the inner wall of the shaft: 30 mm for circular section shafts and 20 mm in the event of a square section shaft (Fig. 42).

Maximum 2 changes of direction are allowed on the vertical section of the flue system with a maximum clearance angle of 30° with respect to the vertical.

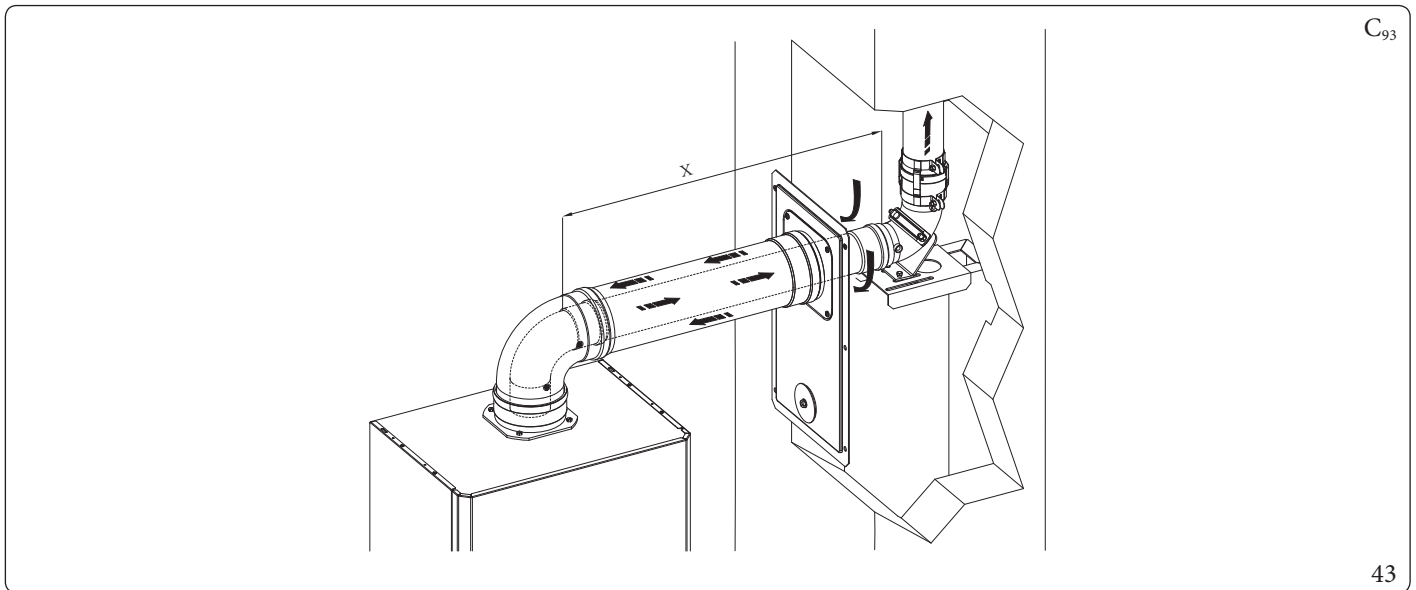

The maximum lengths ((L max) of the various flues that can be installed are given in the summary table in parag. 1.16.

1.23 CONFIGURATION C₍₁₅₎ CONCENTRIC KIT

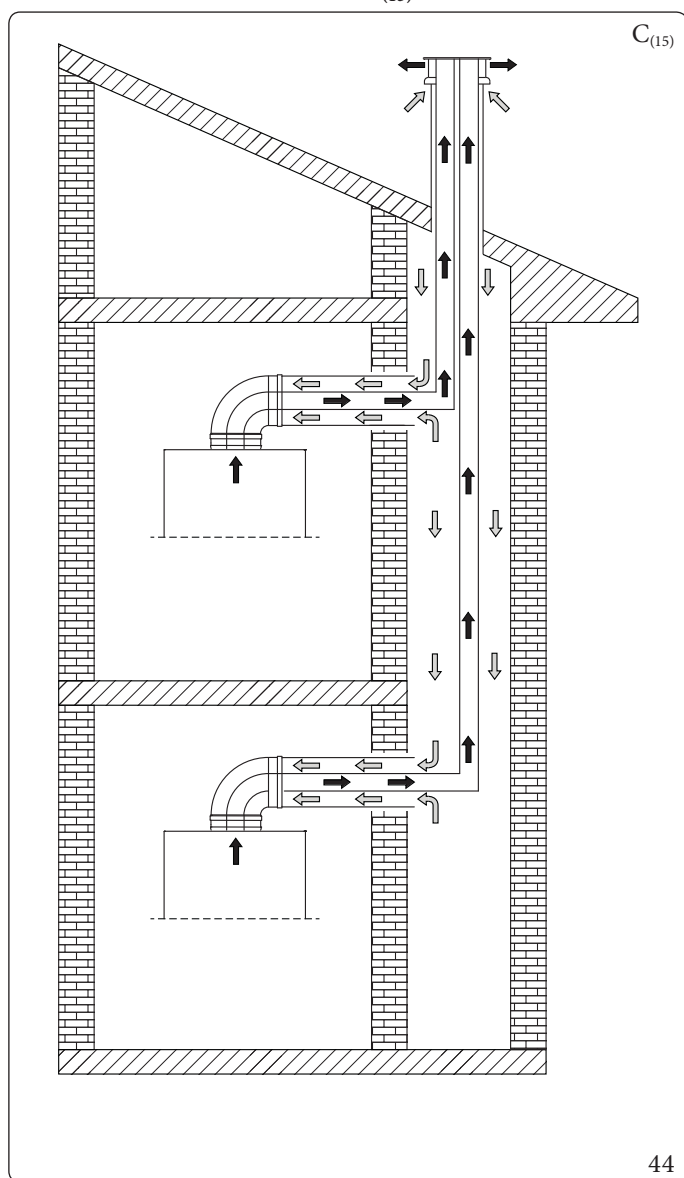

Installation in C₍₁₅₎ configuration of an Immergas appliance, makes it possible to intake combustion air directly from the shaft where the flue gas exhaust is present in the dedicated flue.

Information for C₍₁₅₎ installations

The appliance is suitable for operating in a C₍₁₅₎₃ or C_{(15)3X} system, correctly sized by a thermotechnical designer.

The roof terminal, which is an integral part of the project, must also meet the legislative and regulatory obligations prescribed for this component. In particular, it must ensure that the degree of recirculation of the flue gas is always below 10%.

The common supply shaft must be sized so that, in combination with the intake part of the roof terminal, a vacuum greater than 5 Pa is not generated at the point of the shaft where the appliance draws the combustion air from the shaft itself, when the appliance works at maximum heat output and the entire multiple ducting system works at maximum design power.

If the single terminal complies with the following head losses conditions at the maximum appliance heat input:

Model	Pa
Victrix Maior 35 Plus	10

in compliance with the conditions described above, the maximum extensions that can be achieved in the shaft are those defined in this manual with C₉₃ configuration, using the same appliance settings.

1.24 CONFIGURATION C₍₁₀₎ CONCENTRIC KIT (Ø 80/125)



In the C₍₁₀₎ and C₍₁₂₎ installations, the appliance flue exhaust must be fitted with a flue gas non-return valve kit, supplied by Immergas as an optional, consisting of the valve itself with instructions and relative sticker with additional safety information (Fig.45).

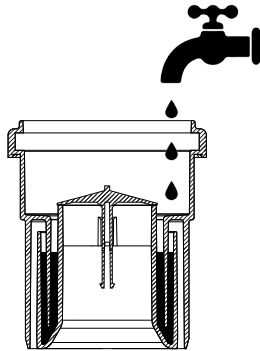

45

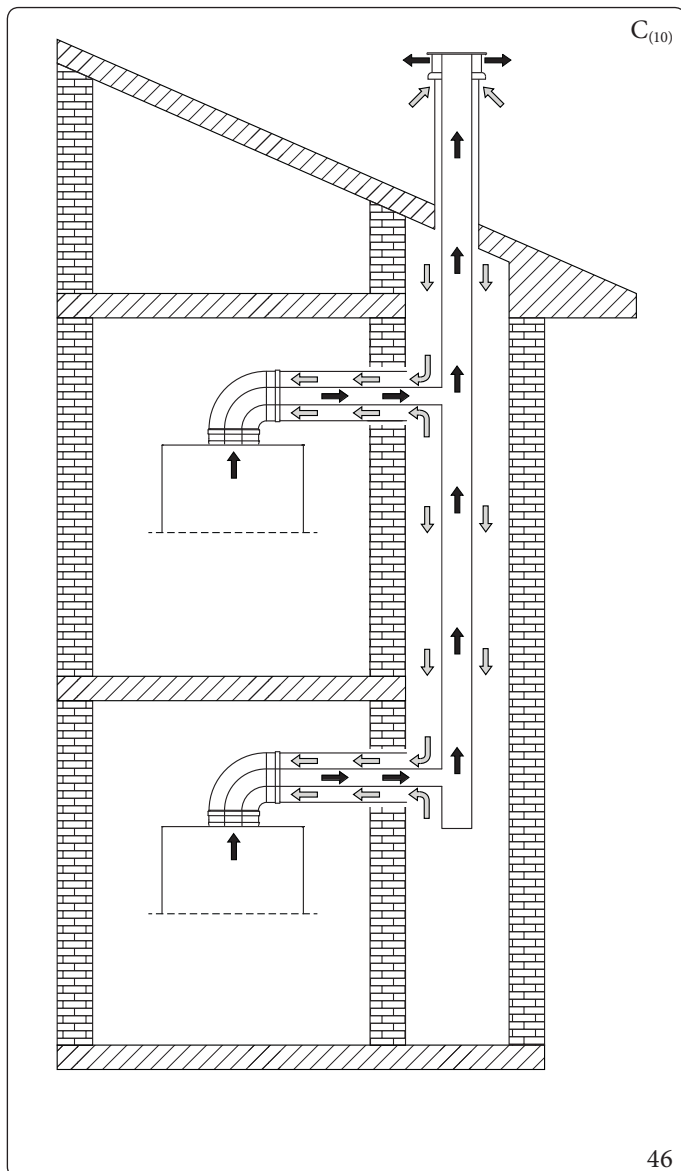

46

Installation in C₍₁₀₎ configuration of an Immergas appliance (only permitted with approved original flue, including the specific non-return valve), makes it possible to intake combustion air directly from the shaft where the flue gas exhaust is present in the collective flue.



Coupling to the shaft for intake is possible with male flue Ø 125 or Ø 125 cut female.

The collective flue coupling for the exhaust is possible with female Ø 80 flue with gasket. (Fig. 48)

INSTALLER

USER

MAINTENANCE TECHNICIAN

TECHNICAL DATA

Concentric kit assembly in C₁₀ type configuration (Fig.48)



To aid in the removal of possible condensate forming in the exhaust pipe, tilt the pipes towards the appliance with a minimum slope of 5% (Fig.47)

1. Position the flanged adaptor (14) interposing the concentric gasket (15) on the appliance, fitting it with the screws (13).
2. Insert the non-return valve kit on flue gas Ø80 in the flanged adaptor, taking care to remove the spacer Ø 80 th. 5 mm.



Make sure to fill the flue gas non-return valve siphon with water (Fig. 45):

3. Fit the Ø 125 extension in the flanged adaptor.
4. Insert the Ø 80/125 bend on the non-return valve.
5. Calculate the distances between the bend and the connection to the collective flue and the shaft.
6. Adapt the extension (10), calculating that the inner pipe of the concentric kit must fit as far as it will go into the collective flue. The outer pipe must engage up to the door.



Before mounting it, ensure that the gaskets are in the correct position.

In the event component lubrication (already carried out by the manufacturer) is not sufficient, remove the residual lubricant using a dry cloth, then to ease fitting coat the parts with common or industrial talc.

7. Mount the cover (A) complete with adaptor (1) and caps (6) on the wall.
8. Assemble the flue to the collective flue exhaust system.
9. Set parameter F.1 = 1.
10. Perform the automatic calibration procedure (Parag.3.10).

Once all components have been assembled properly, the exhaust flue gas will be expelled in the collective flue, the combustion air for normal appliance operation will be aspirated directly by the shaft (Fig. 43).

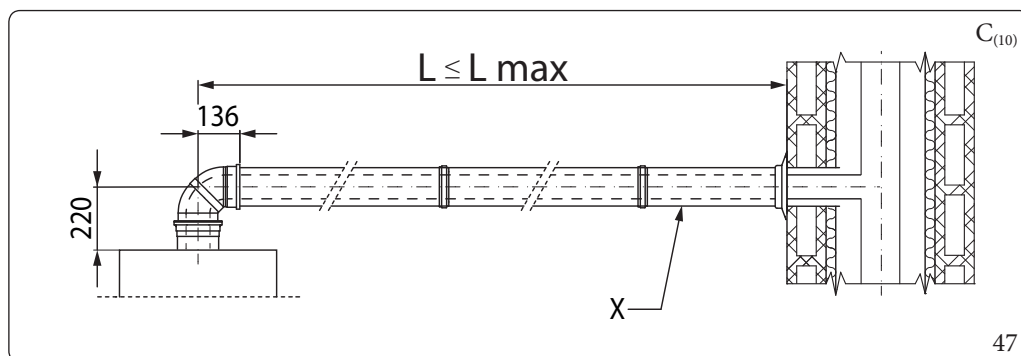

Key (Fig. 47):

- X - Minimum slope 5%
- L - Equivalent length
- L max - Maximum length



The maximum lengths ((L max) of the various flues that can be installed are given in the summary table in parag. 1.16.

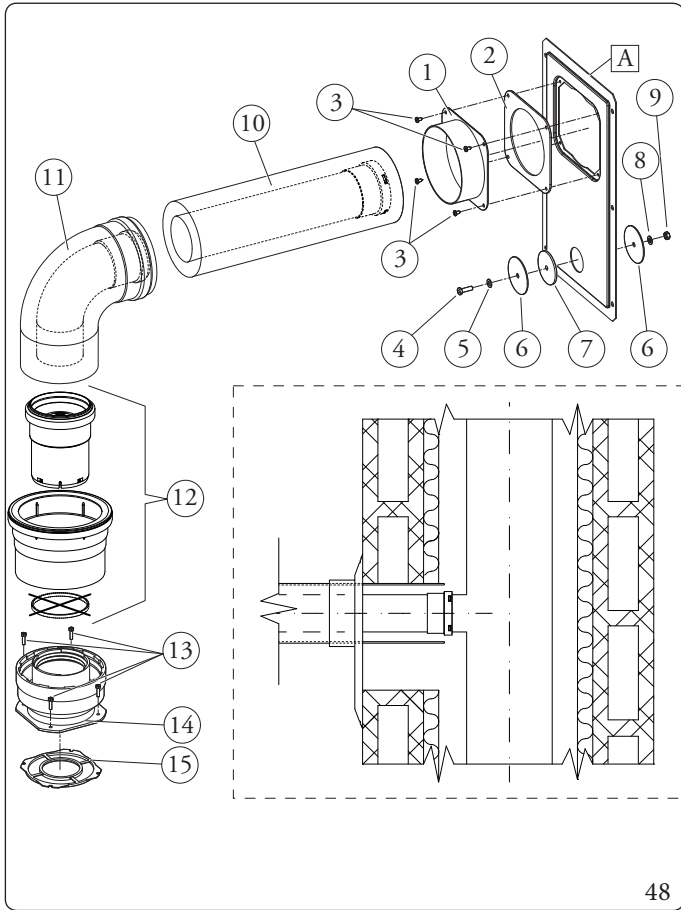

48

Key (Fig. 48):

The C₍₁₀₎ adaptor kit includes:

- 1 Door adaptor Ø 100 or Ø 125 (1)
- No.1 Door gasket made of neoprene (2)
- No.4 Screws 4.2x9 ST (3)
- No.1 Hex headed screw M6x20 (4)
- No.1 Flat nylon washer M6 (5)
- No.2 Door hole closure metal-sheet plate plug (6)
- No.1 Pluggasket made of neoprene (7)
- No.1 Toothed washer M6 (8)
- No.1 M6 nut (9)

The Ø80/125 extension pipe kit includes:

- 1 Extension pipe unit Ø80/125 (10)

The bend kit Ø80/125 includes:

- 1 Concentric bend Ø80/125 at 87° (11)

The non-return valve kit on the flues Ø80 (12) includes:

- 1 Gasket Ø80
- 1 Non-return valve on flues Ø80
- 1 Extension Ø125
- 1 Spacer Ø80 th. 5 mm (to be excluded for this configuration)
- No.1 Information sticker

The adaptor kit includes:

- 4 (kit Ø80/125) M4 hex headed screws x 16 slotted screwdriver (13)
- 1 (kit Ø80/125) Flanged adapter Ø80/125 (14)
- 1 (kit Ø80/125) Concentric gasket (15)

Supplied separately (Fig. 48):

- No.1 Ducting kit door (A)

INSTALLER

USER

MAINTENANCE TECHNICIAN

TECHNICAL DATA

1.25 CONFIGURATION C₍₁₀₎ - C₍₁₂₎ SEPARATOR KIT (Ø 80/80)



In the C₍₁₀₎ and C₍₁₂₎ installations, the appliance flue exhaust must be fitted with a flue gas non-return valve kit, supplied by Immergas as an optional, consisting of the valve itself with instructions and relative sticker with additional safety information (Fig.45).

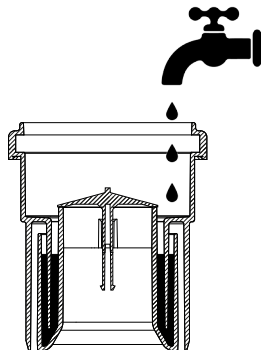

49

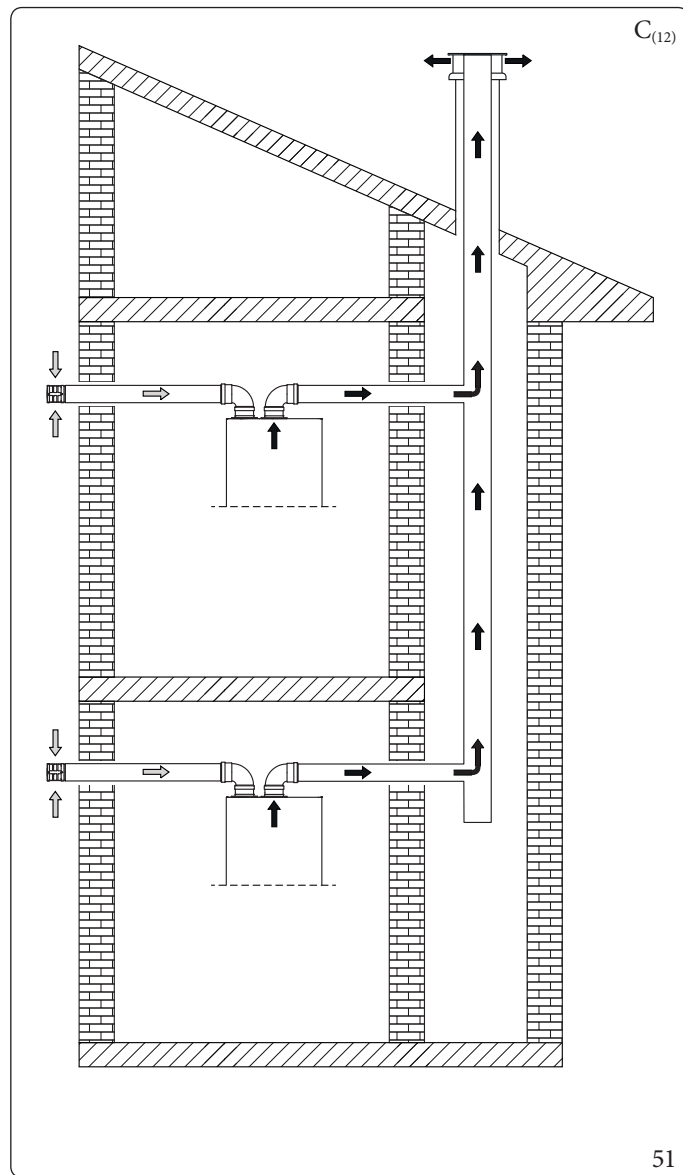
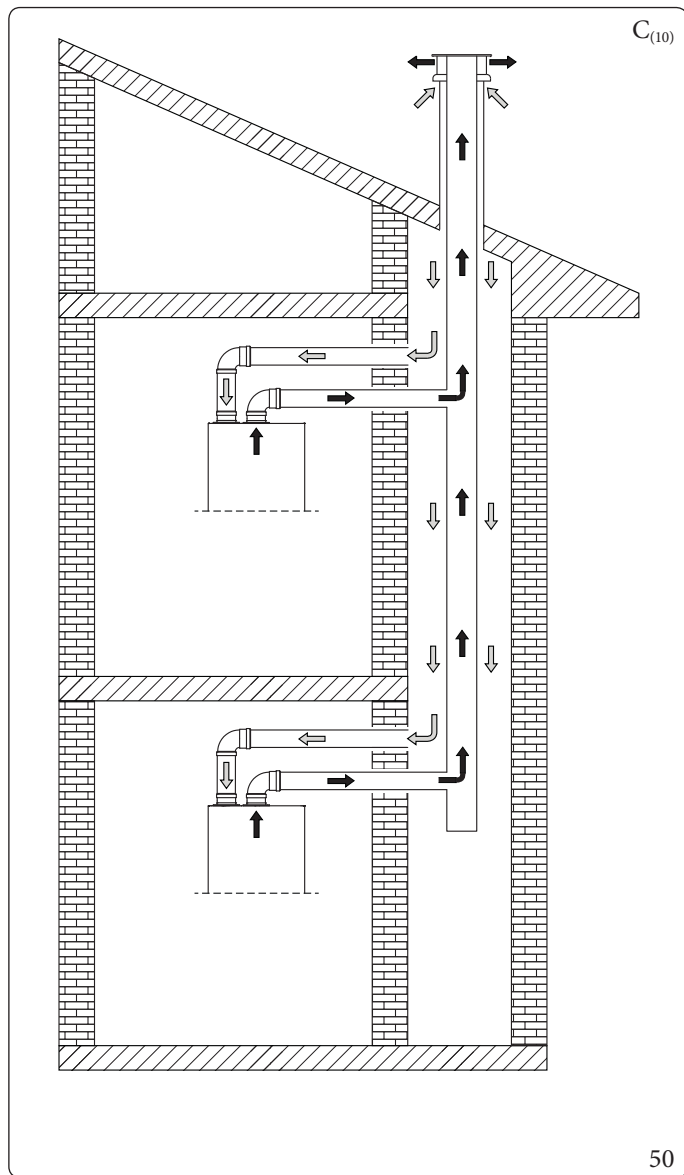

This configuration (allowed only with the approved original flue, including the specific non-return valve), makes it possible to suck the air outside the home or directly from the shaft where the flue gas exhaust is present and the evacuation of the flue gas itself inside a collective flue.



$C_{(10)}$ (Fig. 50):

Coupling to the shaft for intake is possible with male flue $\varnothing 80$ or $\varnothing 80$ cut female.

$C_{(10)}$ - $C_{(12)}$ (Fig. 50 - 51)

The collective flue coupling for the exhaust is possible with female $\varnothing 80$ flue with gasket.

Assembly of separator kit $\varnothing 80/80$ (Fig. 52):

1. Install the discharge flange (4) on the appliance sample point flange, positioning the relative gasket (1) with the circular projections downwards in contact with the appliance flange, and tighten using the hex screws with flat tip contained in the kit.
2. Remove the flat flange present in the intake hole and replace it with the intake flange (3), positioning the gasket (2) contained in the separator kit $\varnothing 80/80$ and tighten using the supplied self-threading screws.
3. Eliminate the extension $\varnothing 125$ from the non-return valve kit on the flue gas.
4. Insert the spacer $\varnothing 80$ th. 5 mm into the flue exhaust flange.
5. Insert the flue gas non-return valve on the $\varnothing 80$ flues inside the flue exhaust flange.



Make sure to fill the flue gas non-return valve siphon with water (Fig. 45):

6. Fit the bends with male side (smooth) (5) in the female side of the flanges (3 and 4).
7. For intake from shaft ($C_{(10)}$) i.e. from common intake duct, connect the intake ducts $\varnothing 80$ (6) to the bend (5), making sure that the internal wall sealing plate (7) has already been inserted. For wall intake ($C_{(12)}$), fit the intake terminal (6) with the male side (smooth) in the female side of the bend (5) up to the end stop, ensuring that the internal (7) and external (8) wall sealing plates are fitted.
8. Connect the $\varnothing 80$ drain pipe making sure to have already inserted the internal wall sealing plate (7) inside the end section of the pipe.
9. Set parameter F.1 = 1.
10. Perform the automatic calibration procedure (Parag. 3.10).

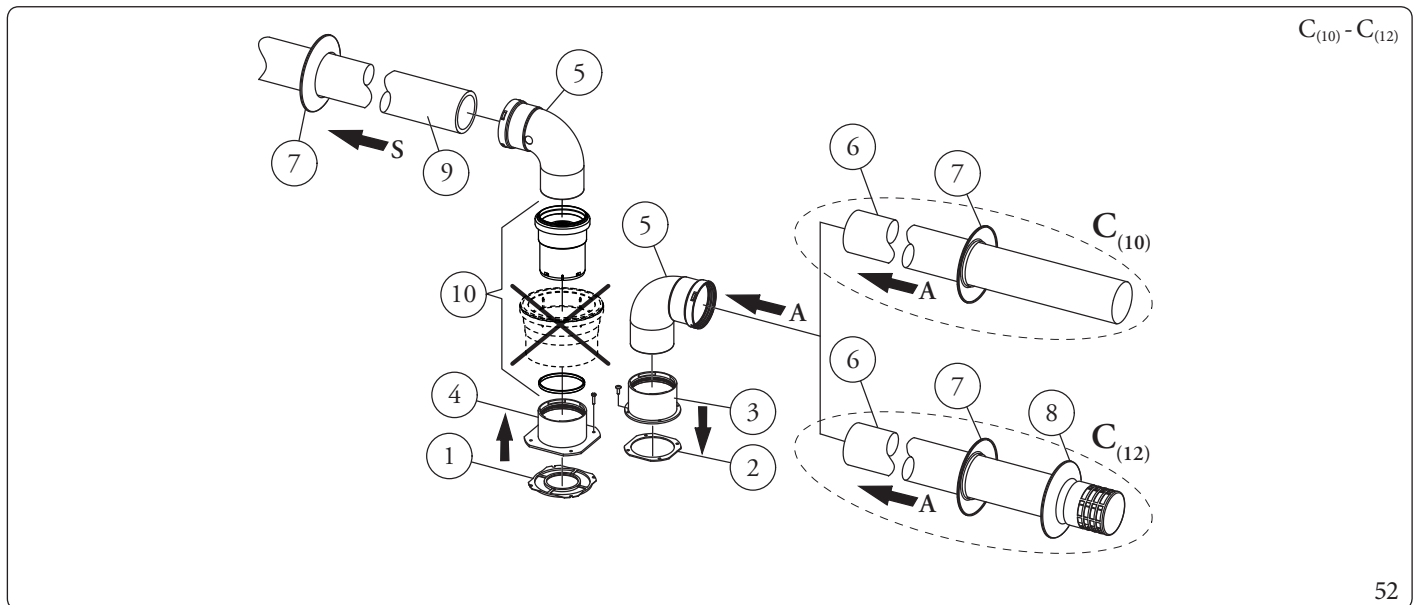

The kit includes (Fig. 52):

- No.1 Exhaust gasket (1)
- No.1 Flange gasket (2)
- No.1 Female intake flange (3)
- No.1 Female exhaust flange (4)
- No.2 Bend $90^\circ \varnothing 80$ (5)
- No.1 Extension $\varnothing 80$ (6) (only $C_{(10)}$)
- No.1 Intake terminal $\varnothing 80$ (6) (only $C_{(12)}$)

- No.2 Internal wall sealing plates (7)
- 1 External wall sealing plate (8) ($C_{(12)}$) only
- No.1 Exhaust pipe $\varnothing 80$ (9)
- N°1 Non-return valve on flue gas $\varnothing 80$ (10)
- N.B.: remove extension $\varnothing 125$**

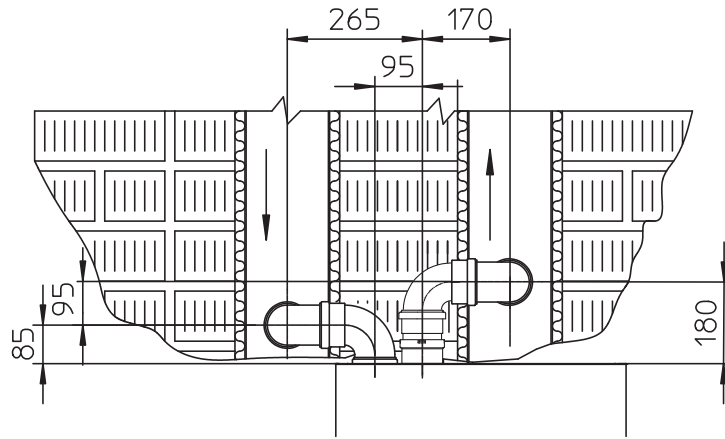

C₍₁₀₎

53

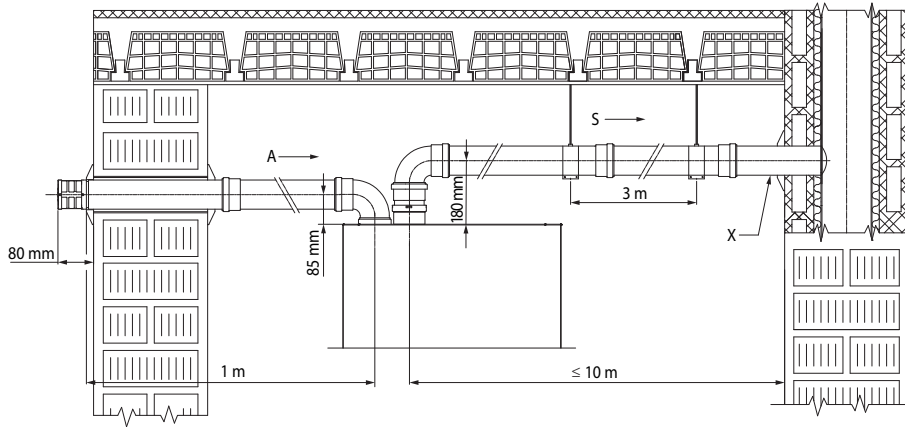

C₍₁₂₎

Key (Fig. 54):

- A - Intake
- X - Minimum slope 5%
- S - Exhaust

54

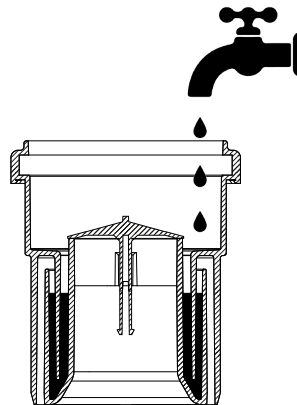

55

Information for installations C₍₁₀₎ and C₍₁₂₎



The appliance is suitable for operation in a C₍₁₀₎ or C₍₁₂₎ system only with the supply of methane gas (2H and 2E categories).

The appliances are developed to operate on collective pressurised flues with a safety pressure at the minimum heat input of 25 Pa and a safety pressure at the maximum heat input of 100 Pa.



In boilers installed in flue systems type C₍₁₀₎ or C₍₁₂₎, the parameter "Presence of clapet valve on flue gas" (F.1 = 1) must be enabled, which will require automatic calibration. This is the only calibration operation permitted as CO₂ emission levels are affected by the operating pressures induced in the collective flue, with particular reference to the minimum heat input or any recirculation phenomena induced by the flue system.

The appliance must be connected to a flue system designed by a heating engineer in accordance with EN 13384-2.

The collective flue system must be suitably sized to allow the appliance to operate with the following specifications with which it was designed:

- the maximum pressure, when n-1 appliance is working at maximum heat input (with n= number of total appliances connected or that can be connected to the same collective duct), and a boiler works at minimum heat input, is 25 Pa;
- the minimum pressure difference allowed between the combustion product outlet and the combustion air inlet is -200 Pa (- 400 Pa for C₍₁₂₎) including -100 Pa (-300 Pa C₍₁₂₎) of pressure generated by wind;
- the duct must have been sized with a nominal temperature of the combustion products of 25°C.
- the maximum allowed recirculation rate for wind action is 10%;
- the common flue must be certified to admit an overpressure of at least 200 Pa (minimum pressure class P1);
- no draught-breaker devices must be provided in the duct system.

In particular, at the coupling point to the pressurised collective flue, a plate must be visible showing at least the following technical information:

- the name and trademark of the common flue gas pipe manufacturer;
- suitability for operation with certified boilers C₍₁₀₎ or C₍₁₂₎;
- the maximum flue gas mass value allowed in kg/h;
- the dimensions of the common duct (collective pipe) for each push fit point;



The openings for combustion air and the inlet of combustion products of the pressurised collective flue must be closed and their tightness must be checked when the appliance is disconnected.

The appliance connection to the pressurised collective flue must be made as instructed, without exceeding the specific maximum extensions stated.

The flue pipe must be inclined (5% slope) towards the appliance to facilitate the evacuation of condensate.



The appliance flue gas outlet must be installed with the flue gas non-return valve kit, which ensures correct operation of the appliance and facilitates its maintenance operations.

Furthermore, the safety sticker must be affixed on the front casing. This sticker is contained in the appropriate Kit C₍₁₀₎ C₍₁₂₎, which contains the additional exhaust flue gas non-return valve, necessary for the pressurised collective flues.



It is advisable to affix the sticker in a clearly visible position on the front casing.



When the sealed chamber is opened, combustion products may escape even when the appliance is turned off.

Summary table of information for C₁₀ installations (Only Methane 2H - 2H)

		VICTRIX MAIOR 35 PLUS	
		Q _{min}	Q _{nmax}
Heat input	kW	2,8	34,0
CO ₂ % of reference	%	8,8	8,8
Maximum boiler outlet pressure	Pa	25	93
Minimum boiler outlet pressure C ₁₀	Pa	-200	-200
Minimum boiler outlet pressure C ₁₂	Pa	-400	-400
Maximum flue gas flow rate	kg/h	57	
Minimum flue gas flow rate	kg/h	5	
Flue gas temperature 80°C\60°C	°C	79	
Maximum flue duct length 80\125	m	9	
Maximum flue duct length 80\80	m	10	
Available head with maximum duct length	Pa	56,0	
Boiler settings (as indicated in the instruction booklet)	-	See Par. 1.25 from point 9 on.	

1.26 DUCTING OF FLUES OR TECHNICAL SLOTS

Ducting is an operation through which, via the introduction of one or more relevant pipes, one achieves a system for the evacuation of the combustion products of a gas appliance, made up from the coupling of an existing or new ducting pipe with a chimney, flue or technical slot (also in new buildings) (Fig. 56).

Ducting requires ducts declared to be suitable for the purpose by the manufacturer, following the installation and user instructions, provided by the manufacturer and the requirements of the regulations in force.

Immergas ducting systems



The $\varnothing 60$ rigid, $\varnothing 50$ and $\varnothing 80$ flexible and $\varnothing 80$ rigid "Green Range" ducting systems must only be used for domestic use and with Immergas condensing boilers.

In any case, ducting operations must respect the provisions contained in the standard and in current technical regulations; in particular, the declaration of conformity must be compiled at the end of work and on commissioning of the ducted system.

The instructions in the project or technical report must likewise be followed, in cases provided for by the standard and current technical regulations.

To guarantee reliability and operation over time of the ducting system, make sure:

- it is used in average atmospheric and environmental conditions, according to current regulations (absence of combustion products, dusts or gases that can alter the normal thermophysical or chemical conditions; existence of temperatures coming within the standard range of daily variation, etc.).
- Installation and maintenance must be performed according to the indications supplied by the manufacturer included with the "green range" ducting system chosen and in compliance with the regulations in force.
- To guarantee long-time reliability and functionality of the ducting system, the maximum length specified by the manufacturer (Par. 1.16) must be complied with.

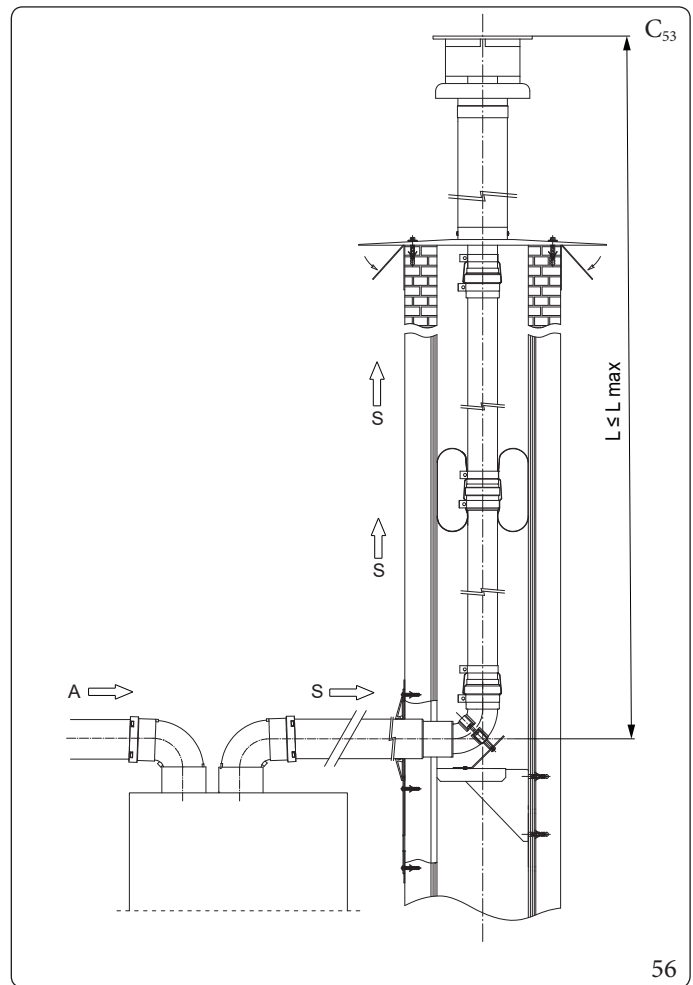

The maximum lengths ((L max) of the various flues that can be installed are given in the summary table in parag. 1.16.

1.27 CONFIGURATION FOR C₆ FLUE INSTALLATION



Appliance designed to be connected to a commercial exhaust/intake system.

Gas type		G20	G31
Flue temperature at maximum output	°C	78	77
Flue gas mass at maximum power	kg/h	55	55
Flue temperature at minimum output	°C	56	53
Flue gas mass at minimum power	kg/h	5	5
CO ₂ at Q. max.	%	8,8 (8,3 ÷ 9,3)	10,0 (9,5 ÷ 10,5)
CO ₂ a Q. minimum	%	8,8 (8,3 ÷ 9,3)	9,5 (9,0 ÷ 10,0)
Maximum head available at maximum power (maximum resistance value of the commercial flue system)	Pa	247	
Maximum head available at minimum power	Pa	2	
Maximum temperature that the exhaust pipes can reach	°C	120	



- Ducts must withstand condensation (only for condensing models);
- Air intake ducts must withstand working air temperatures of up to 60°C;
- The maximum permissible percentage of flue gas recirculation in windy conditions is 10%.
- Suction and exhaust pipes cannot be installed on opposing walls;
- With flues in configuration C₆ discharge into pressurised flues is not permitted.

INSTALLER

USER

MAINTENANCE TECHNICIAN

TECHNICAL DATA

1.28 CONFIGURATION TYPE B, OPEN CHAMBER AND FAN ASSISTED FOR INDOORS

The appliance can be installed inside buildings in B₂₃ or B₅₃ mode; in this case, all technical rules and national and local regulations in force, must be complied with.

For installation the cover kit must be used, referred to in Parag. 1.17.

1.29 FLUE EXHAUST TO FLUE/CHIMNEY.

Flue exhaust does not necessarily have to be connected to a branched type traditional flue for type B appliances with natural draught (CCR).

For B₂₃ configurations, exhaust is only allowed into individual chimney or directly into the external atmosphere via a relevant terminal, unless otherwise provided by local regulations.

The flue exhaust, for boiler clots installed in C configuration, can be connected to a single flue or to a multiple flue.

The multiple flues must also only be connected to type C appliances of the same type (condensation), having nominal heat inputs that do not differ by more than 30% less with respect to the maximum that can be attached and powered by the same fuel.

The thermo-fluid dynamic features (flue flow rate, % of carbon dioxide, % humidity etc.) of the appliances attached to the same multiple flues, must not differ by more than 10% with respect to the average appliance attached.

Multiple flues must be specially designed according to the calculation method and requirements of the standards (such as UNI 13384), by professionally qualified technical staff.

Chimney or flue sections for connection of the flue exhaust pipe must comply with requisites of technical standards in force.

It is possible to replace a type C conventional device with one provided with condensation, connected to multiple flues, only if the derogation conditions established by the regulations in force have been met.

1.30 FLUES, CHIMNEYS AND CHIMNEY CAPS.

The flues, chimneys and chimney caps for the evacuation of combustion products must be in compliance with applicable standards.

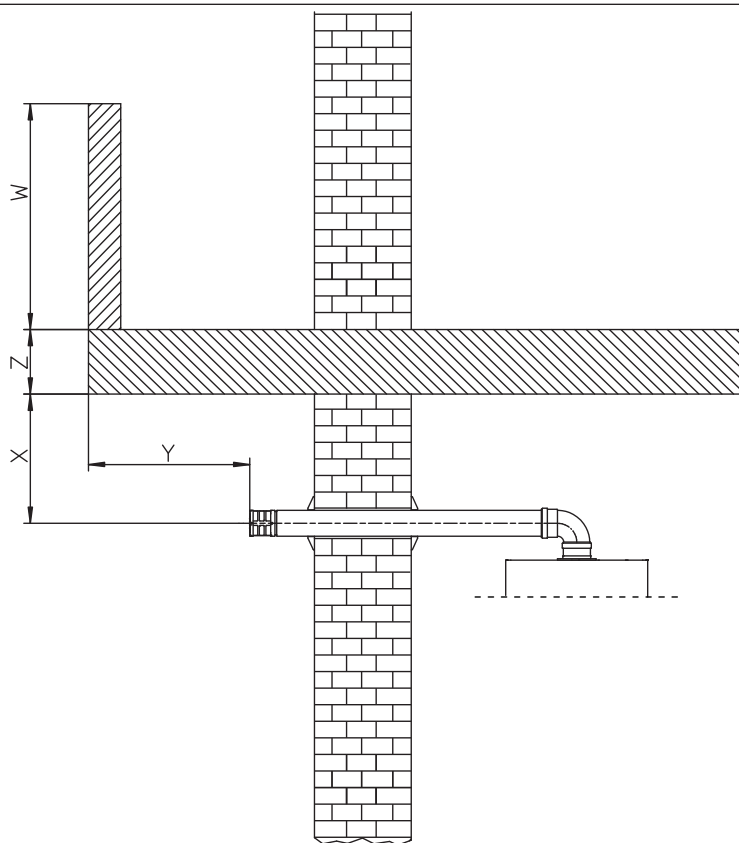

57

Positioning the wall flue exhaust terminals.

The wall flue exhaust terminals must:

- be installed on external perimeter walls of the building (Fig. 57);
- be positioned according to the minimum distances specified in current technical standards.

Combustion products exhaust of natural draught or fan assisted appliances in open-top closed environments.

In spaces closed on all sides with open tops (ventilation pits, courtyards etc.), direct combustion product exhaust is allowed for natural draught or fan assisted gas appliances with a heat input range from 4 to 35 kW, provided the conditions as per the current technical standards are respected.

1.31 WATER TREATMENT PLANT FILLING

As already mentioned in the previous paragraphs, a treatment of the thermal and domestic system water is required, in compliance with the local standards in force.

The parameters that influence the duration and proper operation of the heat exchanger are the water's PH, total hardness, conductivity, and oxygen, together with the system's processing residues (any welding residues), any oil present and corrosion products that can, in turn, cause damage to the heat exchanger.

In order to prevent this from happening, you are recommended to:

- Before installation on new systems as well as old ones, clean the system with clean water to eliminate solid residues.
- clean the system with a chemical treatment:
 - clean the new system with a suitable cleaning device (for example Sentinel X300, Fernox Cleaner F3 or Jenaqua 300) combined with thorough washing;
 - clean the old system with a suitable cleaning device (for example Sentinel X400 or X800, Fernox Cleaner F3 or Jenaqua 400) combined with thorough washing;
- Check the maximum total hardness and amount of filling water with reference to the graph (Fig. 58), if the contents and hardness of the water are below the indicated curve, no specific treatment is required; otherwise, to limit the content of calcium carbonate, you must provide for water-filling treatment.
- If it is necessary to provide for water treatment, it should be done through complete desalination of the filling water. As opposed to the complete softening process, desalinating the water completely not only removes hardening agents (Ca, Mg), but also eliminates all other minerals to reduce water-filling conductivity up to 10 microsiemens/cm. Given its low conductivity, desalinated water does not only prevent the formation of lime scale, but also serves as protection against corrosion.
- Insert a suitable inhibitor / passivator (for example Sentinel X100, Fernox Protector F1, or Jenaqua 100); if required, also insert appropriate antifreeze (such as for example Sentinel X500, Fernox Alphi 11 or Jenaqua 500).
- Check electrical conduction of the water, which should be higher than 2000 $\mu\text{s}/\text{cm}$ in the case of treated water and lower than 600 $\mu\text{s}/\text{cm}$ in the case of non-treated water.
- To prevent corrosion, the water system's PH should be between 7.5 and 9.5.
- Check the maximum content of chlorides, which should be less than 250 mg/l.

i For quantities and methods of use of water-treatment products, refer to the instructions provided by their manufacturer.

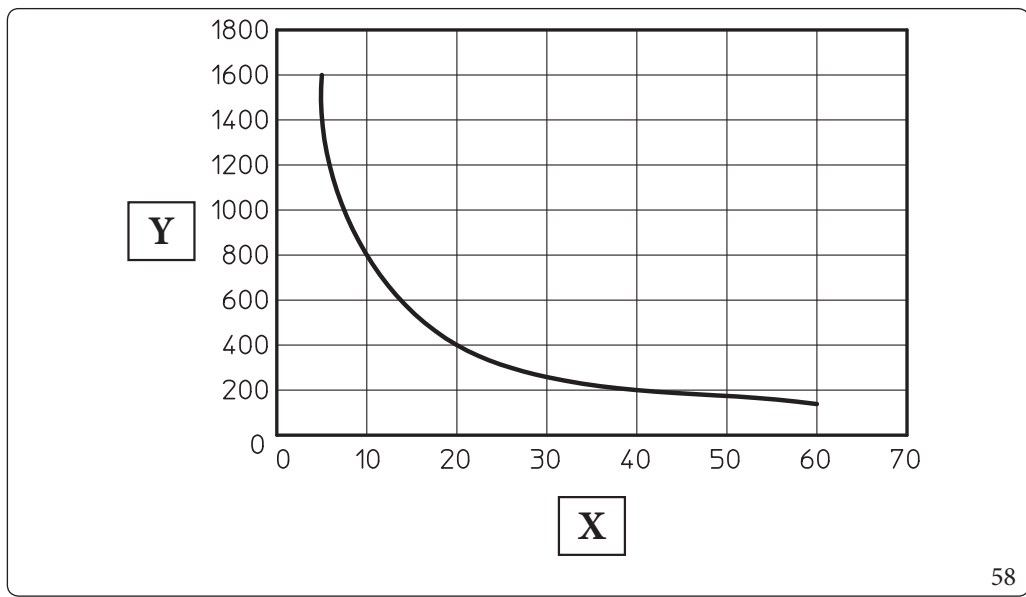

Key (Fig. 58):
 X - Total water hardness °F
 Y - Litres of system water

i The graph refers to the entire life cycle of the system. Therefore, also consider scheduled and unscheduled maintenance, which involves emptying and filling the said system.

INSTALLER

USER

MAINTENANCE TECHNICIAN

TECHNICAL DATA

1.32 SYSTEM FILLING

Once the appliance is connected, proceed with system filling via the filling valve (Part. 32 Fig. 61).

Filling is performed at low speed to ensure release of air bubbles in the water via the appliance and central heating system vents.

The appliance has a built-in automatic vent valve on the pump (Fig. 61).

Then open the radiator vent valves.

Close radiator vent valves when only water escapes from them.

The filling valve must be closed when the appliance pressure gauge indicates approximately 1.2 bar cold.



During these operations, enable the automatic vent functions on the appliance (Parag. 3.17);

1.33 FILLING THE CONDENSATE DRAIN TRAP



When the appliance is switched on for the first time, combustion products come out of the condensate drain. After a few minutes of operation, check that combustion flue gases are no longer coming out of the condensate drain; this means that the drain trap has filled to a correct condensate height that the flue gases cannot pass through.

1.34 GAS SYSTEM START-UP

To start up the system, refer to the technical standards in force.

This divides the systems and, therefore, the commissioning operations, into three categories: new systems, modified systems, reactivated systems.

In particular, for new gas systems:

- open windows and doors;
- avoid presence of sparks or naked flames;
- bleed all air from pipelines;
- ensure the internal system is properly sealed according to the specifications set forth by technical regulations in force.

1.35 APPLIANCE START-UP (IGNITION)

To commission the appliance (the operations listed below must only be performed by qualified personnel and in the presence of staff only):

1. check that the internal system is properly sealed according to the specifications set forth by regulations in force;
2. Ensure that the type of gas used corresponds to the appliance settings (the type of gas appears on the display on first electrical power supply);
3. check that there is no air in the gas pipe;
4. Check connection to a 230V~50Hz power mains, correct L-N polarity and the earthing connection;
5. check that the intake/exhaust terminals are not obstructed and that they are installed properly;
6. **Check that the drain trap is full and that it prevents any passage of flue gas into the room;**
7. check that there are no external factors that may cause the formation of fuel pockets;
8. Carry out the flue test (Par.3.12);
9. **Activate the automatic calibration function (TA) (if in the previous check it was necessary to change the flue parameters):** (Par. 3.10);
10. Switch the appliance on and check correct ignition;
11. Make sure that the gas flow rate and relevant pressure values comply with those given in the manual (Par.4.1);
12. ensure that the safety device intervenes in the event of gas supply failure and check the relative intervention time;
13. Check the activation of the main switch located upstream of the appliance and in the appliance.



Even if just one single safety check provides a negative result, do not commission the system.

1.36 UPM4 CIRCULATION PUMP

The appliances are supplied with a variable speed circulator pump.

In the central heating mode, the following operating modes are available and can be selected from the "P.C.B. programming" menu (Par. 3.13).



The ΔT can be controlled compatibly with the characteristics of the central heating system and of the appliance.

- **Proportional head (A4=0):** the circulator speed varies according to the power emitted by the burner, the greater the power the greater the speed.
- **ΔT Constant (A4=5-25 K):** the pump speed varies to maintain the ΔT constant between the system flow and return according to set value K (A4=15 Default).
- **Fixed:** by setting parameters "A2" and "A3" at the same value (6-9), the pump operates at constant speed. For the boiler to work properly, it is not allowed to drop below the minimum value indicated above.



In domestic hot water mode, the circulator pump always runs at full speed.

Pump symbols (Fig. 59):

With the pump powered and the pwm control signal connected and operating (pump ON or in stand-by), the symbol 2 flashes green ().

If the symbol 2 turns steady green (), the pump detects no command on the pwm signal and always runs at maximum speed.

If the pump detects an alarm, symbol 1 lights up red (). This can mean that there is one of the following faults:

- Low power supply voltage.
- Rotor seized (Cautiously turn the screw in the centre of the head to manually release the motor shaft).
- Electrical error.



These anomalies will be signalled on the boiler display as errors "60" or "61" as indicated in par. 2.5.

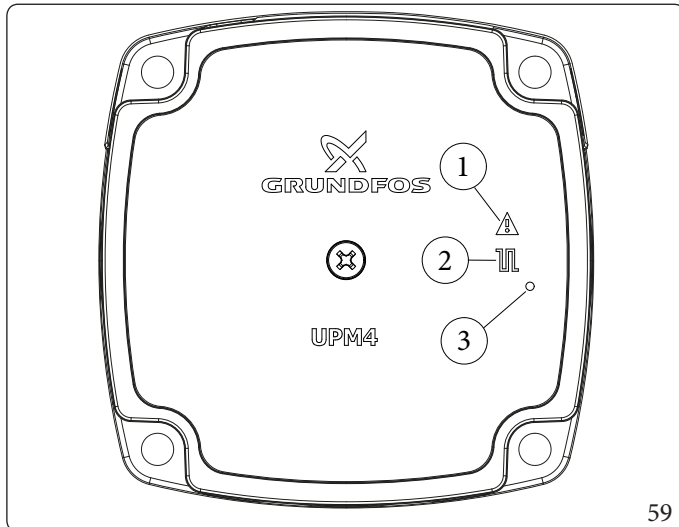

Key (Fig. 59):

- 1 - Alarm signal (Red)
- 2 - Functioning status signal (Steady green/Flashing green)
- 3 - Led (Not used on this model)

Pump release.

If after a long period of inactivity, the circulator is blocked, adjust the screw in the centre of the head in order to manually release the motor shaft.

Take great care during this operation to avoid damage to the motor.

Bypass Regulation (Ref. 26 Fig. 61):

The appliance leaves the factory with the bypass open.

If necessary, the by-pass can be regulated to system requirements from minimum (by-pass closed) to maximum (by-pass open).

Adjust using a flat head screwdriver, turn clockwise and open the by-pass, anticlockwise it is closed.



The bypass ensures minimum circulation of the water in the appliance and its correct operation if the systems are divided into more than one zone.

Head available to the Victrix Maior 35 Plus system

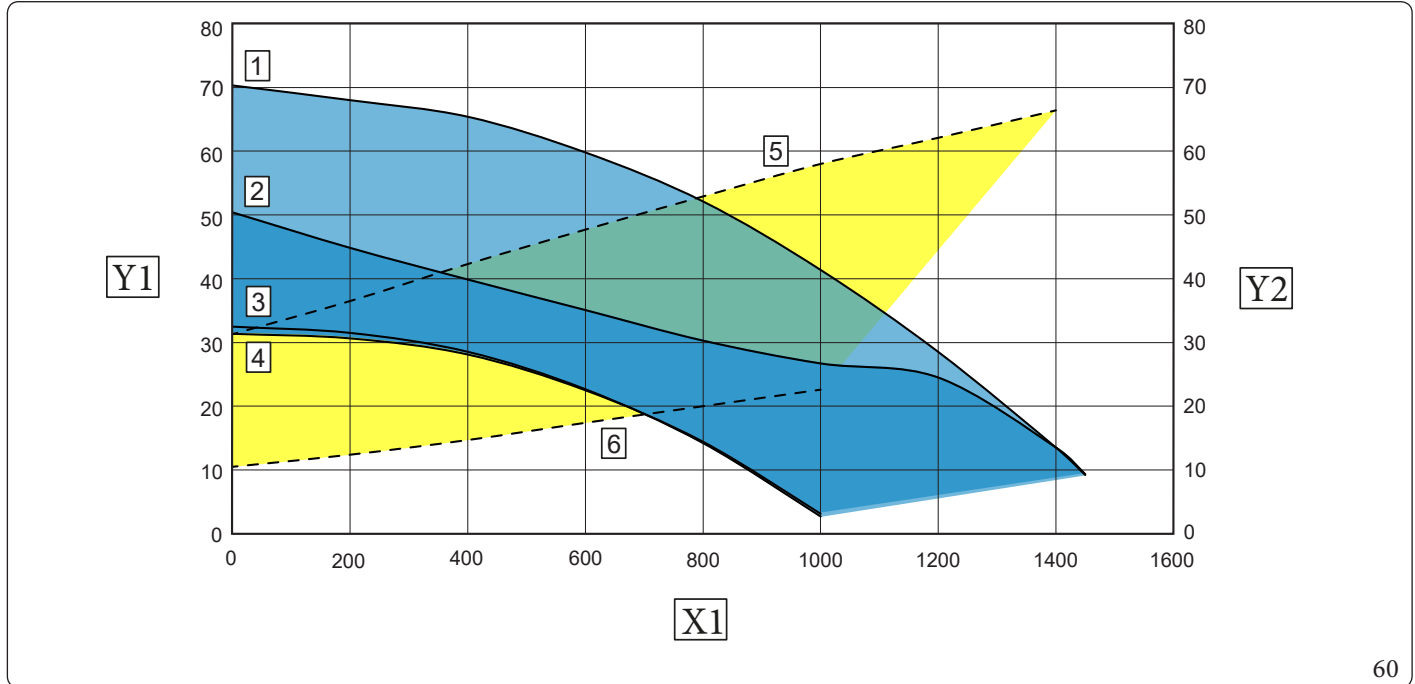

Key (Fig. 60):

- 1 = Head available to the system at speed 9 with by-pass closed
 - 2 = Head available to the system at speed 9 with by-pass open
 - 3 = Head available to the system at speed 6 with by-pass closed
 - 4 = Head available to the system at speed 6 with by-pass open
 - 5 = Circulator power input at Speed 9 with closed by-pass
 - 6 = Circulator power input at Speed 6 with closed by-pass
- Area between curves 1 and 3 = Available system head with bypass closed
Area between curves 2 and 4 = Available system head with bypass open
Area between curves 5 and 6 = Circulator absorbed power with bypass closed

- X1 = Flowrate (l/h)
- Y1 = Head (kPa)
- Y2 = Power absorbed by pump (W)



The data of the graph(s) above include the cyclonic filter, which is standard in these models.

1.37 KITS AVAILABLE ON REQUEST



Check the complete list of kits available and which can be combined with the product, consult the Immergas website, the Immergas Price List or the technical-commercial documentation (catalogues and data sheets).

INSTALLER

USER

MAINTENANCE TECHNICIAN

TECHNICAL DATA

1.38 MAIN COMPONENTS

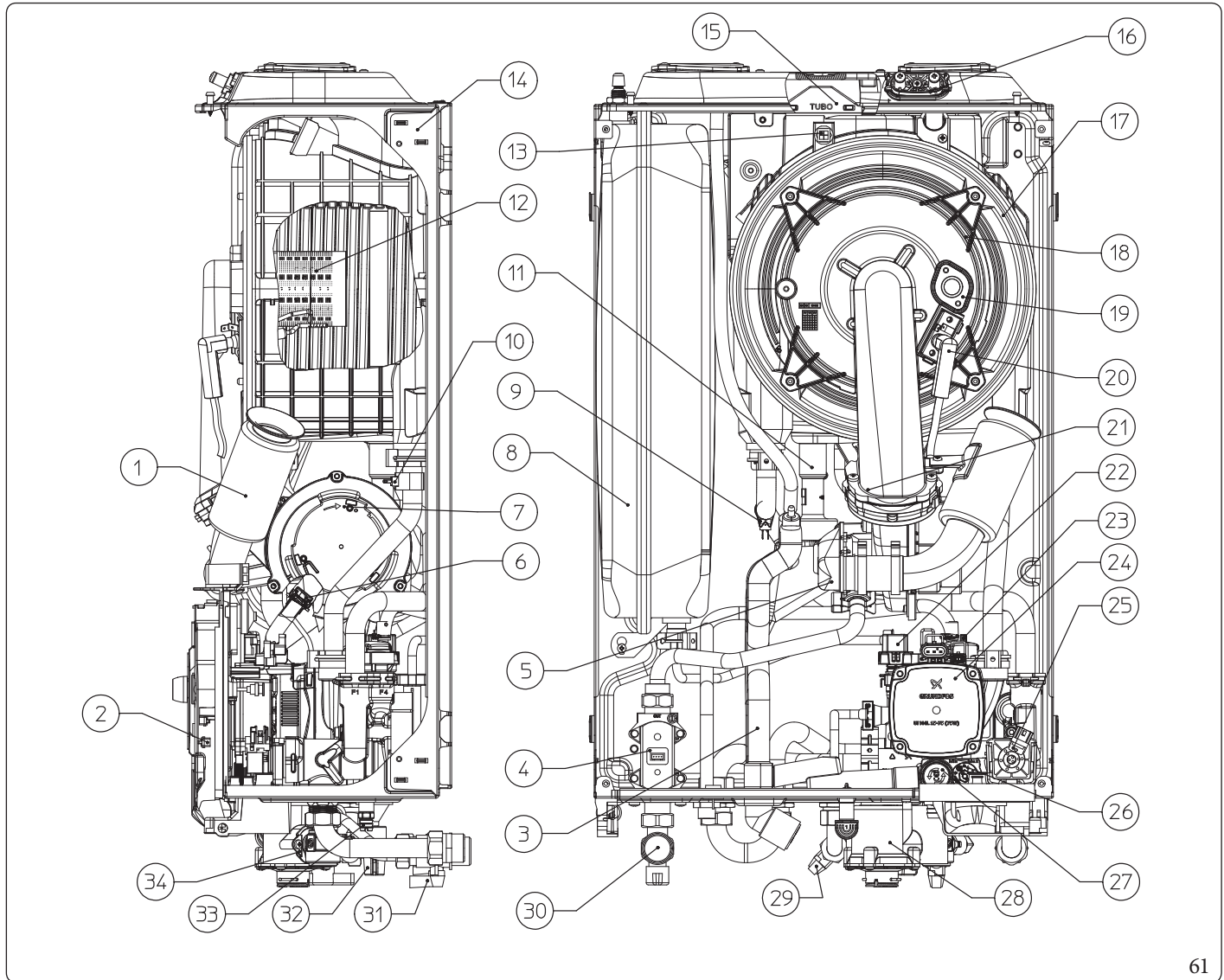

Key (Fig. 61):

- | | | | | | |
|----|---|---|----|---|-------------------------------------|
| 1 | - | Air intake pipe | 18 | - | Condensation module gas manifold |
| 2 | - | Control panel unit | 19 | - | Gas manifold inspection hole flange |
| 3 | - | Condensate drain trap | 20 | - | Ignition and detection electrode |
| 4 | - | Gas valve | 21 | - | Flue gas non-return valve |
| 5 | - | Gas mixer | 22 | - | Pressure transducer |
| 6 | - | Gas diaphragm | 23 | - | Automatic circulator vent valve |
| 7 | - | Fan | 24 | - | Pump |
| 8 | - | Expansion vessel | 25 | - | 3-way valve (motorised) |
| 9 | - | System flow probe | 26 | - | By-pass |
| 10 | - | System return probe | 27 | - | 3 bar safety valve |
| 11 | - | Condensate drainage siphon extension | 28 | - | Cyclonic filter unit |
| 12 | - | Burner | 29 | - | Cold water inlet valve |
| 13 | - | Double flue probe sensor | 30 | - | Gas isolation valve |
| 14 | - | Frame unit | 31 | - | Cyclonic filter interception valve |
| 15 | - | Flue gas flange | 32 | - | System filling valve |
| 16 | - | Flue gas sampling cap with pressure point | 33 | - | System draining valve |
| 17 | - | Condensation module | 34 | - | Cyclonic filter interception valve |

INSTALLER

USER

MAINTENANCE TECHNICIAN

TECHNICAL DATA

61

2 INSTRUCTIONS FOR USE AND MAINTENANCE

2.1 GENERAL RECOMMENDATIONS



Never expose the wall-mounted appliance to direct vapours from a hob.



The device can be used by children at least 8 years old as well as by persons with reduced physical, sensory or mental capabilities, or lack of experience or required knowledge, provided that they are under surveillance, or after they have been instructed relating to the safe use and have understood the potential dangers.

Children must not play with the appliance.

Cleaning and maintenance destined to be performed by the user can not be carried out by unsupervised children.



For safety purposes, check that the air intake/flue exhaust terminals (if fitted) are not blocked.



If temporary shutdown of the appliance is required, proceed as follows:

- a) drain the heating system if antifreeze is not used;
- b) shut-off all electrical, water and gas supplies.



In the case of work or maintenance to structures located in the vicinity of ducting or devices for flue extraction and relative accessories, switch off the appliance and on completion of operations ensure that a qualified technician checks efficiency of the ducting or other devices.



Never clean the appliance or connected parts with easily flammable substances.



Never leave containers or flammable substances in the same environment as the appliance.



Do not open or tamper with the appliance.



Do not take apart or tamper with the intake and exhaust pipes.



Only use the user interface devices listed in this section of the booklet.



Do not climb on the appliance, do not use the appliance as a support base.



In the event of malfunctions, faults or incorrect operation, turn the appliance off and contact an authorised company (e.g. the Authorised Technical Assistance Centre, which has specifically trained staff and original spare parts).

Do not attempt to modify or repair the appliance alone.



The use of components involving use of electrical power requires some fundamental rules to be observed such as:

- do not touch the appliance with wet or moist parts of the body; do not touch when barefoot;
- never pull electrical cables or leave the appliance exposed to atmospheric agents (rain, sunlight, etc.);
- the appliance power cable must not be replaced by the user;
- in the event of damage to the power supply cable, switch off the appliance and contact exclusively qualified staff for replacement;
- if the appliance is not to be used for a certain period, disconnect the main appliance external switch.



Water at a temperature of more than 50 °C can cause serious burns. Always check the water temperature before any use.



The temperatures indicated by the display have a tolerance of +/- 3°C due to environmental conditions that cannot be blamed on the appliance.



If you smell gas in the building:

- close the gas meter interception device or the main interception device;
- if possible, close the gas interception valve on the product;
- if possible, open doors and windows wide and create an air current;
- do not use open flames (e.g. lighters, matches);
- do not smoke;
- do not use electrical switches, plugs, door bells, telephones or intercom devices in the building;
- call an authorised company (e.g. Authorised Technical Assistance Centre).



if you smell burning or see smoke coming out of the appliance, switch it off, disconnect power, close the main gas isolation valve, open the windows and call an authorised company (e.g. Authorised Technical Assistance Centre).



At the end of its service life, the appliance must not be disposed of like normal household waste nor abandoned in the environment, but must be removed by a professionally authorised company as required by current legislation.
Contact the manufacturer for disposal instructions.

2.2 CLEANING AND MAINTENANCE



To preserve the appliance's integrity and keep the safety features, performance and reliability, which distinguish it, unchanged over time, you must execute maintenance operations on a yearly basis in compliance with what is stated in the relative point at "annual check and maintenance of the appliance", in compliance with national, regional, or local standards in force.

2.3 CONTROL PANEL

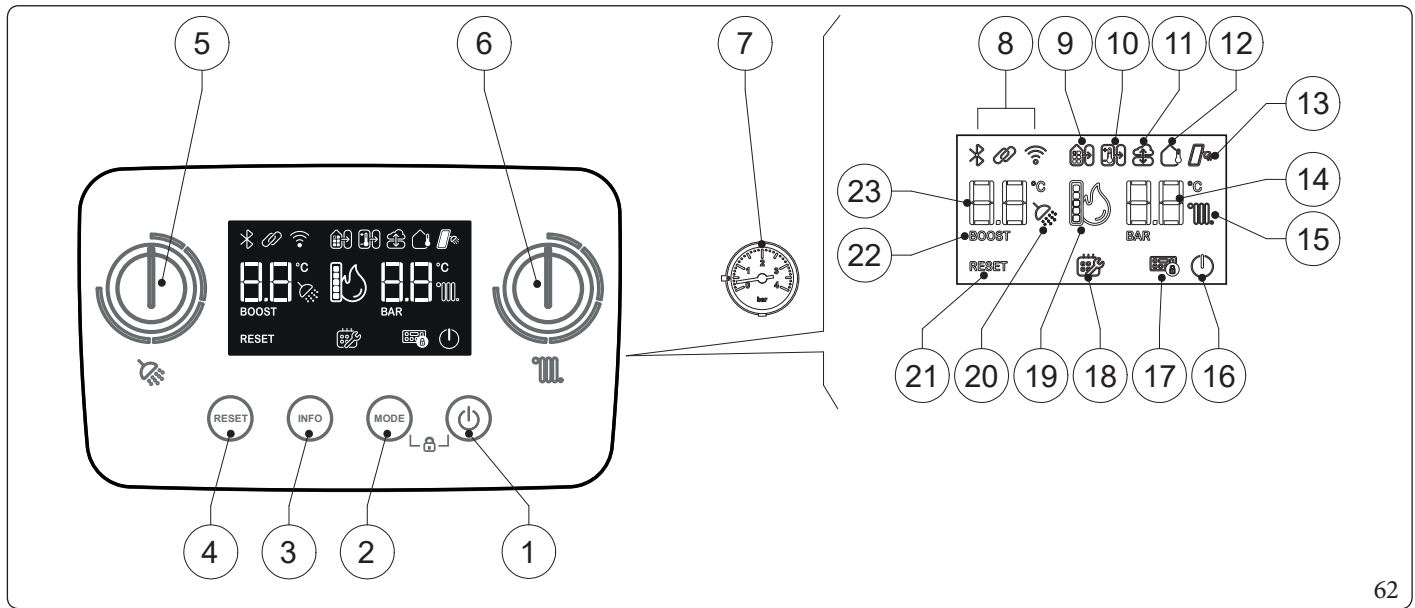















Key (Fig. 62):

- 1 - ON/OFF/Stand-by button.
- 2 - DHW ONLY / DHW + CH / CH ONLY operating mode button.
- 3 - Information buttons.
- 4 - Reset Button.
- 5 - Domestic hot water temperature control knob.
- 6 - System water flow temperature control knob.
- 7 - Boiler manometer.
- 8 - System general icon display.
- 9 - Connection to other Immergas units.
- 10 - Remote control connection (optional).
- 11 - External server connection.
- 12 - Operation with external temperature probe active (optional).

- 13 - Solar operation enabled/active.
- 14 - Central heating / C.H. set display.
- 15 - Room central heating phase operation enabled/active.
- 16 - Boiler in OFF/Stand-by mode.
- 17 - Keyboard lock active.
- 18 - Programmed maintenance request.
- 19 - Flame presence symbol and relative output scale.
- 20 - DHW production phase operation enabled/active.
- 21 - Blocked boiler, it needs to be unblocked by pressing the "Reset" button.
- 22 - DHW recirculation active (optional)
- 23 - DHW (Domestic hot water) set display.

2.4 USING THE APPLIANCE

Symbol	Description and operation
	Not used
	Not used
	Not used
	- The symbol on steady indicates the presence of a remote device connected, e.g.: CARv2, Smartech Plus, commercial remote. It is also active in stand-by and when displaying faults.
	- A permanently active symbol indicates the presence of a zone control unit or a BMS system. It is also active in stand-by and when displaying faults.
	Not used
	The symbol indicates the presence of an external probe. It is also active in stand-by and when displaying faults.
	The symbol indicates that the boiler is connected to the external server and can be controlled via App (e.g. Dominus).
BOOST	- The symbol is on steady when the 'DHW recirculation' function is enabled. - The symbol is flashing when the 'DHW recirculation' function is running. Also displayed when a fault is in progress.
RESET	- The symbol flashes when there are faults that must be or can be reset manually. - The symbol flashes when special functions are in progress that can be stopped by pressing the key.
	- The symbol is permanently active if a service call for maintenance is requested. - The symbol flashes during calibration. It is also active in stand-by.
	- The symbol is on steady when the keyboard lock is active. - The symbol flashes when the user presses a key while the keyboard lock is active. It is also active in stand-by and when displaying faults.
	- The symbol on steady indicates that the boiler is in Stand-by at the request of a remote device. - The symbol is flashing when the boiler is in OFF; the setting can only be activated or deactivated from the control panel.
	- The symbol is permanently active when the boiler can meet a DHW request. - The symbol flashes during a DHW request or during the chimney sweep function. They are also displayed during the de-aeration function and with a fault in progress.
	- The symbol is permanently active when the boiler can meet a C.H. request. - The symbol flashes during a C.H. request or during the chimney sweep function. They are also displayed during the de-aeration function and with a fault in progress.
	The flame icon is only present when the burner is on. The bars represent the output power level.



Before ignition make sure the heating system is filled with water and that the manometer (7) indicates a pressure of 1 - 1.2 bar cold.

Operation without Comando Amico Remoto remote control v2.

- Open the gas isolation valve upstream from the appliance.



To activate a command, first activate the keyboard (by pressing any button), then press the desired button and activate the desired function.

- If the boiler is in OFF mode (ⓘ flashing), press the button (1) again to activate it. If not, go to the next point.

Press the 'MODE' button (2) in succession to cycle through the status:

- DHW + C.H. (☼ + 🌡);
- DHW ONLY (☼);
- CH ONLY (🌡).

DHW ONLY mode (☼)

In this mode the boiler functions only to produce the DHW, the temperature is set via the knob (5) and the relative temperature is shown on the display via the indicator (23).

C.H. mode ONLY (🌡)

In this mode the boiler functions only for room central heating, the temperature is set via the knob (6) and the relative temperature is shown on the display via the indicator (14).

DHW + C.H. mode (☼ + 🌡)

In this mode, the boiler functions both for producing domestic hot water and heating the environment. The temperature of the DHW is always regulated via knob (5), the central heating temperature is regulated via knob (6) and the relative temperatures are shown on the display by the indicators (14-23).

If both CH and DHW are requested at the same time, the boiler will give priority to the DHW request and central heating will not be available until the DHW request is completed.

Each time the burner ignites, the relative Flame Present symbol is displayed (21) with relative output scale.

Operation with Comando Amico Remoto v2 (CARv2) (optional)

If the CARv2 is connected, the symbol (📶) appears on the display and the boiler control parameters can only be set from the control panel of the CARv2. However, the Reset button (4), the ON/OFF button (1) and the display where the operating status is shown remain active on the boiler control panel. From the control panel of the CARv2 it is not possible to set the 'Central Heating Only' mode. You may select:

- the 'Summer' mode, which corresponds to the 'DHW Only' mode;
- the 'Winter' mode, which corresponds to the 'DHW + Central Heating' mode.

(Please refer to the remote control instruction manual for more information).

If the boiler is in OFF (ⓘ flashing), it is not possible to change this status from the remote control and a fault will be displayed on the remote control. To reactivate the boiler, press the button (1). Once reactivated, the boiler control parameters can be set from the control panel of the CARv2.

Operation with external probe  (optional)

In the case of a system with an external probe, the boiler flow temperature for central heating is managed by the external probe depending on the external temperature measured (Parag. 1.12). The flow temperature can be modified by selecting the functioning curve via the knob (6) (or on the CARv2 control panel, if connected to the boiler) selecting a value from 0.0 to 9.0.

With external probe present, the relative symbol  will appear on the display.

OFF mode

Press the button (1); from this moment the boiler remains inactive and the display shows the symbol ( flashing). Antifreeze and anti-jamming function is guaranteed according to the set stand-by level.

Any remote controls cannot bring the boiler out of this state.

Stand-by mode (Only available with Remote Control connected).

The boiler can ONLY be put into stand-by mode by a remote control: in this case the symbol () appears steady on the display.







In "Stand-by" and "OFF" mode, the appliance is to be considered still live.

Display lighting

The display lights up while the control panel is being used; after a set inactivity period, the brightness decreases. The lighting mode can be varied via parameter "t8" in the P.C.B. programming menu.

Keypadlock

Pressing the buttons (, MODE) simultaneously for more than 5 seconds locks the keyboard and the display shows (). From this moment on, the knobs and buttons have no function. Any interaction causes symbol 17 () to flash. To unlock the keyboard, press the two buttons (, MODE) simultaneously until symbol 17 () goes out.

DHW recirculation function (optional)

When the function is active, the word 'BOOST' appears on the display.

The function allows the domestic hot water recirculation ring to be kept at the temperature, if the system has been set up, so as to allow rapid availability of domestic hot water when a withdrawal is made. To activate and configure the optional kit necessary for this function, contact an Authorised After-sales Centre.

Operation with zone card connected on DimBUS

By connecting the zone card (optional) to DimBus, the flow temperature settings of the three zones can be set by turning the CH knob (6). The display will then show the setting of the first zone (u1) and you can change its value by turning the CH knob (6).

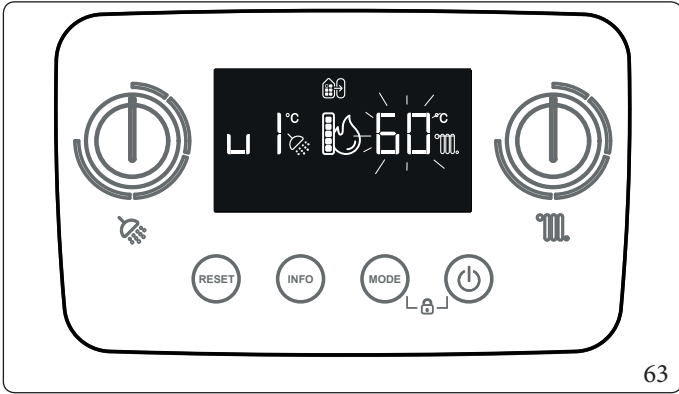

If the optional outside sensor is present, the flow temperature calculation curve is set depending on the outside temperature (Parag. 1.12).

Confirming the value with MODE will display the setting of the second zone (u2), which can be changed in the same way by subsequently accessing the third zone (u3).

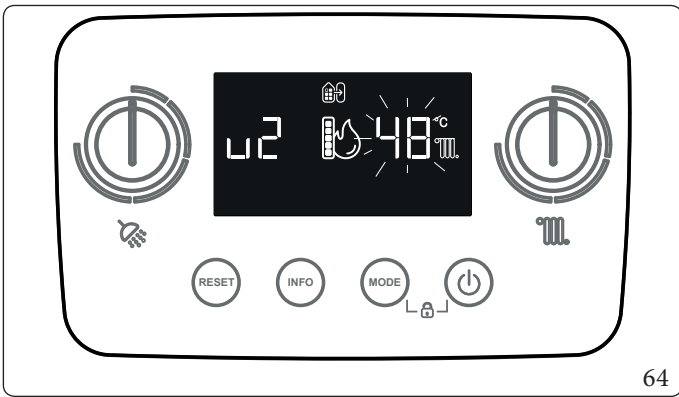

When the third zone mode is over, the display will return to the standard display.

2.5 FAULT AND ANOMALY SIGNALS

The appliance signals any anomalies using a code shown on the boiler display Fig. 62) secondo la tabella seguente.

Error Code	Anomaly signalled	Cause	Appliance status / Solution
01	No ignition block	In the event of request of room central heating or domestic hot water production, the boiler does not switch on within the preset time. Upon appliance commissioning or after extended downtime, it may be necessary to eliminate the block.	Press the Reset button (1)
02	Safety thermostat block (overheating safety device)	During normal operation, if a fault causes excessive overheating internally, the boiler goes into overheating block.	Press the Reset button (1)
03	Flue safety thermostat block	During normal operation, if a fault causes excessive flue gas overheating, the boiler blocks.	Press the Reset button (1)
04	Contacts resistance block	The P.C.B. detects a fault on the gas valve supply. Check its connection. (the anomaly is detected and displayed only in the event of a request).	Press the Reset button (1)
05	Delivery probe fault	The board detects an anomaly on the flow NTC probe.	The appliance does not start (1)
07	Chimney sweep function	The boiler is in chimney sweep or calibration operation.	(3)
08	Maximum N° of resets	Number of allowed resets already performed.	The anomaly can be reset 5 times consecutively, after which the function is inhibited for at least one hour. One attempt is gained every hour for a maximum of 5 attempts. By switching the appliance on and off again, the 5 attempts are re-acquired.
10	Insufficient system pressure	Water pressure inside the central heating circuit that is sufficient to guarantee the correct operation of the boiler is not detected.	Check the appliance pressure gauge to ensure the system pressure is between 1-1.2 bar and restore the correct pressure, if necessary.
(1) If the shutdown or fault persists, contact an authorised company (e.g. Authorised Service Centre)			
(2) The anomaly can only be verified in the list of errors in the "Information" menu			
(3) Error displayed only on CAR^{v2}			
(4) Error displayed only on Anomalies log			
(5) In case of inconsistency between error displays between boiler panel and remote control, the boiler panel prevails			

Error Code	Anomaly signalled	Cause	Appliance status / Solution
12	Storage tank probe anomaly	The board detects an anomaly on the storage tank probe.	The appliance cannot produce domestic hot water (1)
15	Configuration error	If the board detects an anomaly or incongruity on the electric wiring, the boiler will not start.	If normal conditions are restored, the appliance restarts without having to be reset. Check that the boiler is configured correctly (1)
16	Fan anomaly	This occurs if the fan has a mechanical or electrical fault.	Press the Reset button (1)
20	Parasite flame block	This occurs in the event of a leak on the detection circuit or anomaly in the flame control unit.	Press the Reset button (1)
23	Return probe anomaly	The board detects an anomaly on the return NTC probe.	The appliance always works with the pump at maximum speed (1)
24	Push button control panel anomaly	The board detects an anomaly on the pushbutton panel.	If normal conditions are restored the boiler restarts without having to be reset (1)
29	Flue probe anomaly	The board detects an anomaly on the flue gas probe.	The appliance does not start (1)
30	Combustion model setting request	The combustion model identification parameter setting is incorrect or does not support the firmware evolution of the combustion control board.	(1)
31	Loss of remote control communication	This occurs if an incompatible remote control is connected, or if communication between the boiler and the remote control is lost or incorrect connection to the terminals.	Disconnect and reconnect the power to the appliance. If the Remote Control is still not detected on re-starting, the appliance will switch to local operating mode, i.e. using the controls on the control panel. Check the correct connection to the terminals (1).
35	Electric power supply mains frequency anomaly	The board detects a main supply voltage frequency anomaly.	The appliance does not start (1)
36	IMG Bus communication loss	Communication between the various components is interrupted due to an anomaly on the boiler control unit, on the zone control unit or on the IMG Bus.	The appliance does not satisfy the central heating requests (1)
(1) If the shutdown or fault persists, contact an authorised company (e.g. Authorised Service Centre)			
(2) The anomaly can only be verified in the list of errors in the “Information” menu			
(3) Error displayed only on CAR^{v2}			
(4) Error displayed only on Anomalies log			
(5) In case of inconsistency between error displays between boiler panel and remote control, the boiler panel prevails			

Error Code	Anomaly signalled	Cause	Appliance status / Solution
37	Low power supply voltage value	This occurs when the power supply voltage is lower than the allowed limits for the correct boiler operation.	If normal conditions are restored, the appliance restarts without having to be reset (1)
38	Loss of flame signal	This occurs when the boiler is ignited correctly and the burner flame switches off unexpectedly; a new attempt at ignition is performed and if normal conditions are restored, the boiler does not have to be reset.	If normal conditions are restored, the appliance restarts without having to be reset (1). (1) (2) (4)
43	Block due to loss of flame signal	This occurs if the "Flame signal loss" error occurs many times in a row within a preset period (38).	Press the Reset button, before restarting, the appliance will run a post-ventilation cycle. (1)
44	Block for exceeding gas valve frequent maximum opening time	This occurs if the gas valve remains open for longer than required for normal operation, without the boiler switching on.	Press the Reset button (1)
46	Intervention of DIM v2 safety thermostat or Low temperature safety thermostat outside the boiler	During normal operation, if an anomaly causes excessive overheating of the flow temperature in low temperature conditions, the boiler blocks.	In this case, after suitable cooling, it is possible to reset the thermostat (see relative instructions sheet) (1) (5)
47	Burner power limitation	Should flue high temperature be detected, the boiler reduces power supplied so as not to damage it.	(1)
49	High temperature block on return probe	The temperature measured by the return probe is above 90°C. The block is with manual reset.	When the temperature detected by the return probe drops below 70°C, you may press the Reset button (1)
51	RF communication failure towards CAR v2 RF	If there is no communication between the boiler and Wireless version CAR, an anomaly is signalled. From this moment, it is only possible to control the system by means of the control panel of the boiler itself.	Check operation of the Wireless CAR, check the battery charge (refer to the relative instructions booklet).
(1) If the shutdown or fault persists, contact an authorised company (e.g. Authorised Service Centre)			
(2) The anomaly can only be verified in the list of errors in the "Information" menu			
(3) Error displayed only on CARv2			
(4) Error displayed only on Anomalies log			
(5) In case of inconsistency between error displays between boiler panel and remote control, the boiler panel prevails			

Error Code	Anomaly signalled	Cause	Appliance status / Solution
59	Electric power supply mains frequency anomaly	The board detects a main supply voltage frequency anomaly.	The appliance does not start (1)
60	Anomaly pump blocked	The pump is stopped due to one of the following causes: Impeller blocked, electrical fault.	Try to unblock the pump as described in the relative section. If normal conditions are restored, the appliance restarts without having to be reset (1)
61	Air in circulator pump anomaly	Air is detected inside the pump; the pump cannot work.	Vent the pump and the central heating circuit. If normal conditions are restored, the appliance restarts without having to be reset (1)
62	Calibration required	Missing calibration is detected by the P.C.B. It may occur in the event the P.C.B. is replaced or if the parameters are altered in the air / gas section, thus requiring "automatic calibration".	The appliance does not start (1). Perform automatic calibration.
70	Return/flow probe exchange	In case of an incorrect boiler wiring connection the error is detected	The boiler does not start (1)
72	Calibration required	The P.C.B. detects that some parameters have been altered, thus requiring "automatic calibration".	The appliance does not start (1). Perform automatic calibration.
75	Return and/or flow probe malfunction	Possible failure of one or both system return and flow probes	The boiler does not start (1)
76	Flow and/or return probes temperature drift	A malfunction of one or both system return and flow probes is detected.	The boiler does not start (1)
77	Combustion control anomaly	Out of range current is detected on the gas valve.	The appliance does not start (1)
78	Combustion control anomaly	High current on the gas valve is detected.	The appliance does not start (1)
79	Combustion control anomaly	Reduced current on the gas valve is detected.	The appliance does not start (1)
(1) If the shutdown or fault persists, contact an authorised company (e.g. Authorised Service Centre)			
(2) The anomaly can only be verified in the list of errors in the "Information" menu			
(3) Error displayed only on CARv2			
(4) Error displayed only on Anomalies log			
(5) In case of inconsistency between error displays between boiler panel and remote control, the boiler panel prevails			

INSTALLER

USER

MAINTENANCE TECHNICIAN

TECHNICAL DATA

Error Code	Anomaly signalled	Cause	Appliance status / Solution
80	Block - gas valve driver issue	This occurs in the event of malfunctions of the P.C.B. that controls the valve.	Press the Reset button (1)
83	OFF MODE set on boiler (fault only displayed on remote device)	The boiler is set to OFF mode. Commands sent from the remote device are not executed.	Reactivate all boiler functions by pressing the ON/Stand-by button.
84	Combustion anomaly (Power reduction in progress)	A low supply pressure is detected on the gas line. As a result the appliance power is limited and the anomaly is reported.	If normal conditions are restored, the appliance restarts without having to be reset (1). (1) (2) (4)
87	Block - gas valve control	A malfunction of one of the components that controls the gas valve has been detected.	The appliance does not start (1)
88	Block - gas valve control	A malfunction of one of the components that controls the gas valve has been detected.	The appliance does not start (1)
89	Combustion signal unstable	The flame is unstable due to: presence of flue gas recirculation, wind, unstable gas pressure, unstable fan speed, or due to system malfunction.	The appliance keeps working (1) (2) (4)
90	Combustion signal beyond limit	The combustion signal is beyond the adjustment range required for an extended period of time.	The appliance keeps working (1) (2) (4)
91	Incorrect ignition block	The board has exhausted all possible actions in order to obtain optimal ignition of the burner.	Press the Reset button (1)
92	Fan revs correction limit	The system has exhausted all possible corrections of the number of fan revs.	The appliance keeps working (1) (2) (4)
93	Combustion signal beyond limit	The combustion signal is beyond the adjustment range required for a limited period of time.	The appliance keeps working (1) (2) (4)
94	Combustion anomaly	A problem is detected on the combustion control, which may be due to: gas low pressure, flue recirculation, defective gas valve or P.C.B.	If normal conditions are restored, the appliance restarts without having to be reset (1). (1) (2) (4)

(1) If the shutdown or fault persists, contact an authorised company (e.g. Authorised Service Centre)

(2) The anomaly can only be verified in the list of errors in the "Information" menu

(3) Error displayed only on CAR^{v2}

(4) Error displayed only on Anomalies log

(5) In case of inconsistency between error displays between boiler panel and remote control, the boiler panel prevails

Error Code	Anomaly signalled	Cause	Appliance status / Solution
95	Combustion signal discontinuous	The system detects a discontinuous combustion signal.	The appliance keeps working (1) (2)
96	Clogged flue	This occurs in the event an obstruction is detected in the flue system.	The appliance does not start (1). If normal conditions are restored the boiler restarts without having to be reset If error 96 appears after the Technician has made changes on the "flue" parameters, it is necessary to perform a "quick calibration".
97	Timed Service operation request warning	The time range envisaged by the Assistance Centre for scheduled maintenance has expired.	Error only displayed on remote device (if present) (1)
98	Block - maximum no. of software errors	The maximum number of software errors possible has been reached.	Press the Reset button (1)
138	Screed heater in progress	Signalling to remote screed heater function devices (except CAR ^{v2}).	(1)
139	Deaeration in progress	Signalling to remote venting function devices (except CAR ^{v2}).	(1)
146	System pressure too high	The system pressure sensor has detected very high pressure.	The boiler stops working (1) (5)
(1) If the shutdown or fault persists, contact an authorised company (e.g. Authorised Service Centre)			
(2) The anomaly can only be verified in the list of errors in the "Information" menu			
(3) Error displayed only on CAR^{v2}			
(4) Error displayed only on Anomalies log			
(5) In case of inconsistency between error displays between boiler panel and remote control, the boiler panel prevails			

INSTALLER

USER

MAINTENANCE TECHNICIAN

TECHNICAL DATA

2.6 INFORMATION MENU

Press the "INFO" button (pos. 3, Fig. 62) for at least 1 second for the "Information menu" to open, displaying some boiler operation parameters.

To scroll through the various parameters, press the "INFO" button (pos. 3, Fig. 62) and then press 'MODE' to display the value.

To go back to the previous screen or exit the menu, press "RESET" (pos. 4, Fig. 62), or wait 15 minutes.

Parameter ID	Description
d.0	Not used
d.1	Displays the flame signal
d.2	Displays the primary heat exchanger outlet instant CH flow temperature (°C)
d.3	Not used
d.4	Displays the values set for central heating set
d.5	Displays the set value for the DHW set (when paired with a storage tank unit)
d.6	Displays the external environment temperature (°C) (if optional external probe present). If the temperature is below zero, the value is displayed flashing.
d.7	Not used
d.8	Displays the system return water temperature (°C)
d.9	Displays the list of the last 5 faults (to scroll through the list, turn the "CH temperature control" knob)
d.10	Anomaly list reset. Once "d.10" is displayed, press MODE; the display shows "--". Then press MODE again for at least 3 seconds; deletion is confirmed via the "88 88" symbols flashing for two seconds.
d.11	Not used
d.12	Displays the pump operating speed
d.13	Not used
d.14	Displays the pump flow rate (l/h)
d.15	Displays the fan operating speed (rpm)
d.16	Displays the temperature read on the flue probe (°C)
d.17	Displays the calculated flow temperature (°C)
d.18	At the end of the screed heater function, displays for how many hours the flow temperature remained at "Top set"
d.19	Displays alternately safety software version, functional software version and MMI display version
d.20	Displays the flow temperature of zone two (°C) (optional)
d.21	Displays the flow temperature of zone three (°C) (optional)
d.22	Not used
d.23	DHW gas valve operation hours (x10)
d.24	C.H. gas valve operation hours (x10)
d.25	Ignition cycle number (x10)
d.26	Not used
d.27	Not used

2.7 APPLIANCE SWITCH-OFF

Switch off the appliance by pressing "⏻" (Det. 1, Fig. 62), disconnect the omni-polar switch outside the appliance and close the gas isolation valve upstream of the appliance.

Never leave the appliance switched on if left unused for prolonged periods.

2.8 RESTORE CENTRAL HEATING SYSTEM PRESSURE

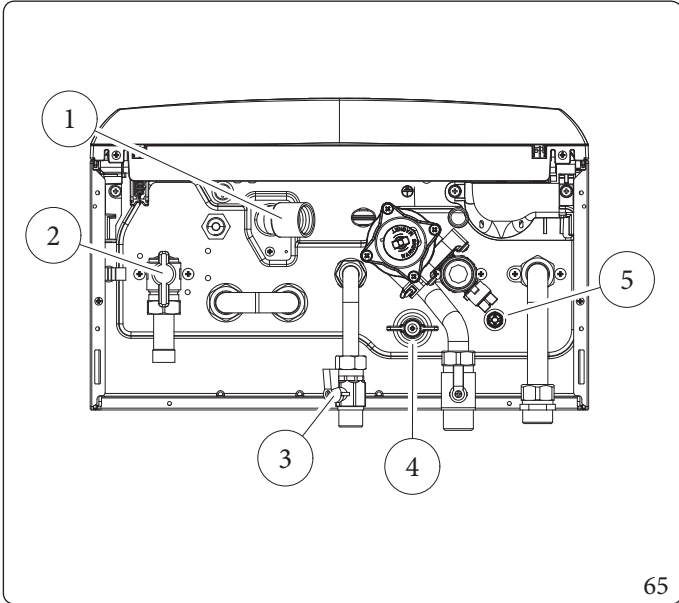

Key (Fig. 65):

- 1 - Safety valve drain
- 2 - GAS isolation valve
- 3 - Cold water inlet valve
- 4 - System filling valve
- 5 - System draining valve

1. Periodically check the system water pressure (the appliance's pressure gauge hand must indicate a cold value between 1 and 1.2 bar).
2. If the pressure is below 1 bar (with the circuit cool), restore normal pressure from the relative valve (Det. 4, Fig. 65).
3. Close the valve after the operation.
4. If the pressure rises to values close to 3 bar, there is a risk of the safety valve tripping (in this case, remove water from an air release valve on a radiator or by acting on the drain valve (Det. 5, Fig. 65) until the pressure is restored to 1 bar, or call in professionally qualified personnel).



If the system is hot, be sure to let it cool down before draining to avoid the risk of scalding.

5. In the event of frequent pressure drops, contact qualified staff for assistance to eliminate the possible system leakage.

2.9 DRAINING THE SYSTEM

To drain the boiler, use the special draining valve (Part. 5, Fig. 65).
Before draining, ensure that the filling valve is closed.



If fluid containing glycol was added to the system circuit, make sure it is recovered and disposed of in accordance with standard EN 1717.

2.10 ANTIFREEZE PROTECTION

The appliance has an antifreeze function that switches the burner on automatically when the temperature drops below 4°C (standard protection to minimum temperature of -5°C).

In order to guarantee the integrity of the appliance and the domestic hot water heating system in areas where the temperature drops below zero, we recommend protecting the central heating system using anti-freeze liquid and installing the Immergas Antifreeze Kit in the appliance.

All information on antifreeze protection can be found in the Installer section at Parag. 1.4.

2.11 PROLONGED INACTIVITY

In case of prolonged inactivity (e.g. second home), we recommend:

1. close the gas;
2. to switch off the power supply;
3. Completely empty the CH circuit (to be avoided if glycol is present in the system) and the DHW circuit of the appliance (if combined with a storage tank). In systems that are drained frequently, filling must be carried out with suitably treated water to eliminate hardness that can cause lime-scale.

2.12 CLEANING THE CASE

1. Use damp cloths and neutral detergent to clean the appliance casing.



Never use abrasive or powder detergents.

2.13 CLEANING THE KEYBOARD

1. Before cleaning the keyboard, it is recommended to lock it (See "Keyboard Locking" Parag. 2.4) and clean the polished surface using a damp cloth and mild soap.



Never use abrasive or powder detergents.

2.14 PERMANENT SHUTDOWN

In the event of permanent shutdown of the appliance, contact professional staff for the procedures and ensure that the electrical, water and gas supply lines are shut off and disconnected.

2.15 AUTOMATIC VENT MODE

When the function is enabled, every time the boiler is electrically powered, the system automatic Vent function is activated (lasting 8 minutes). This function is displayed on the main screen:

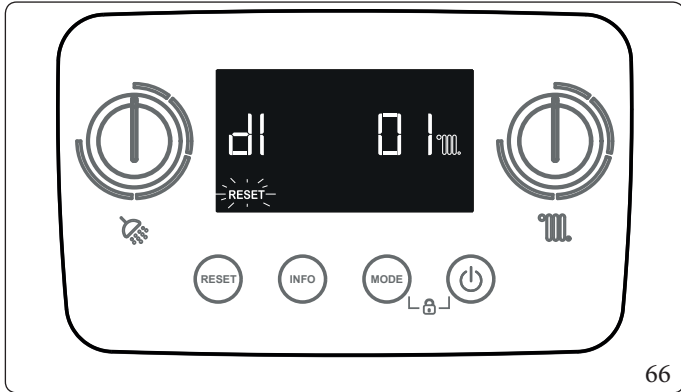

During this period it is not possible to meet the DHW and CH demands.

The "automatic vent" function can be annulled by pressing the Reset button.

3 INSTRUCTIONS FOR MAINTENANCE AND INITIAL CHECK

3.1 GENERAL RECOMMENDATIONS

INSTALLER



Operators who install and service the appliance must wear the personal protective equipment (PPE) required by applicable law.

The list of possible PPE is not complete as they are indicated by the employer.



USER



Before carrying out any maintenance work, make sure that:

- you have disconnected the power to the appliance;
- you have closed the gas isolation valve;
- you have discharged the pressure from the system and domestic hot water circuit (if the storage tank unit is present).



Risk of material damage after using sprays and liquids to search for leaks

Leak sprays and liquids clog the reference hole P.Ref. (Fig. 70) of the gas valve, damaging it irreparably.

During installation and maintenance, do not use spray or liquids in the upper area of the gas valve (electric connections side).

MAINTENANCE TECHNICIAN



Supply of spare parts

The device's warranty shall be rendered null and void if unapproved or unsuitable parts are used for maintenance or repairs. These will also compromise the product's compliance, and the said product may no longer be valid and fail to meet the current regulations. In regard to the above, only use original Immergas spare parts when replacing components.



If additional documentation needs to be consulted for extraordinary maintenance, contact the Authorised After-Sales Service.

TECHNICAL DATA

3.2 INITIAL CHECK

Commissioning the appliance requires you to:

- ensure that the type of gas used corresponds to the appliance settings (the type of gas appears on the display on first electrical power supply, on the data nameplate or, with the display already on, checking parameter G);
- check connection to a 230V-50Hz power mains, correct L-N polarity and the earthing connection;
- make sure the central heating system is filled with water and the cooling appliance pressure gauge reads a pressure of 1-1.2 bar;
- switch the appliance on and check correct ignition;
- check the proper calibration of the number of fan revolutions;
- check the CO₂/O₂ in the flue gas at the flow rate:
 - maximum
 - intermediate
 - minimum
- the values comply with the relevant tables (Par. 3.3);
- fill in and affix the installation information sticker on the appliance next to the data nameplate, with the same data as in this instruction manual, in paragraph 4.4 on the facsimile of the sticker;
- check activation of the safety device in the event of no gas, as well as the relative activation time;
- check the activation of the main switch located upstream of the appliance;
- check that the intake and/or exhaust terminals are not blocked;
- ensure activation of all adjustment devices;
- check the production of DHW (if paired with a storage tank unit);
- check the tightness of the hydraulic circuits;
- check ventilation and/or aeration of the installation room where provided.



Even if just one single safety check provides a negative result, do not commission the system.

INSTALLER

USER

MAINTENANCE/TECHNICIAN

TECHNICAL DATA

3.3 YEARLY APPLIANCE CHECK AND MAINTENANCE



The following checks and maintenance should be performed once a year to ensure operation, safety and efficiency of the appliance over time.

INSTALLER

- Clean the flue side of the heat exchanger.
- Clean the main burner.
- Check the correct positioning, integrity and cleanliness of the detection and ignition electrode; remove any oxide present.
- If deposits are detected in the combustion chamber they must be removed and the heat exchanger coils must be cleaned using nylon or broomcorn brushes; it is forbidden to use brushes made of metal or other materials that may damage the combustion chamber. It is also forbidden to use alkaline or acid detergents.
- Check the integrity of the insulating panels inside the combustion chamber and if damaged replace them.
- Visually check for water leaks or oxidation from/on connections and traces of condensate residues inside the sealed chamber.
- Check the contents of the condensate drain trap.
- Check the presence and cleanliness of the water inlet filter, which guarantees the efficiency of the appliance.

USER

- Visually check that the siphon is properly filled with condensate and top it up if necessary.
- Check that there are no material residues in the condensate drain siphon clogging the condensate passage; also check that the entire condensate drainage circuit is clear and efficient.
- In the event of obstructions (dirt, sediment, etc.) with consequent leakage of condensate in the combustion chamber, one must replace the insulating panels.
- Every time the manifold is opened, the condition and integrity of the ceramic fibres must be verified and replaced, if necessary. The gas manifold gasket, on the other hand, must be replaced every 2 years, regardless of the operating time. After replacing the external silicone gasket, it is mandatory to check the fume tightness.
- Check that the burner is intact, that it has no deformations or cuts and that it is properly fixed to the combustion chamber lid; otherwise it must be replaced.
- Visually check that the water safety drain valve is not blocked.
- Check that the charge of the expansion vessel is 1.0 bar, after having discharged the system pressure and bringing it to zero (readable on the pressure gauge of the appliance).
- Check that the system static pressure (with system cold and after refilling the system by means of the filling valve) is between 1 and 1.2 bar.

MAINTENANCE TECHNICIAN

- Visually check that the safety and control devices have not been tampered with.
- Check the condition and integrity of the electrical system and in particular:
 - the power supply wires must be housed in the cable glands;
 - there must be no traces of blackening or burning.
- Check correct lighting and operation.
- Check the CO₂/O₂ by using the chimney sweep function at the reference heat outputs, using the parameters entered in the following tables. Should values out of the indicated tolerance range be detected, check the calibration again.
- Check correct operation of control and adjustment devices and in particular:
 - system regulation probes intervention;
 - Tripping of the DHW control thermostat (if combined with a storage tank unit).
- Check sealing efficiency of gas circuit and the internal system.
- Check the intervention of the device against no gas ionisation flame control. Intervention time must be 5 seconds.
- Check the flue gas non-return valve at the fan outlet (inside the unit).
- Check and if necessary, clean the siphon of the flue gas non-return valve in the flue in installations C₍₁₀₎ - C₍₁₂₎.



If the flue gas non-return valve in the flues must be removed to inspect and clean it, temporarily plug the exhaust pipe connected to the collective flue. This prevents the return of fumes from the other appliances connected to the flue itself.

TECHNICAL DATA

Gas type	CO ₂ to Nominal Q.	CO ₂ to ignition Q.	CO ₂ to Minimum Q.
G20	8,8 (8,3 ÷ 9,3) %	8,8 (8,3 ÷ 9,3) %	8,8 (8,3 ÷ 9,3) %
G31	10,0 (9,5 ÷ 10,5) %	10,0 (9,5 ÷ 10,5) %	9,5 (9,0 ÷ 10,0) %

Gas type	O ₂ at Nominal Q.	O ₂ at Ignition Q.	O ₂ at Minimum Q.
G20	5,1 (6,0 ÷ 4,2) %	5,1 (6,0 ÷ 4,2) %	5,1 (6,0 ÷ 4,2) %



If a Hydrogen ready installation is planned for H₂ percentages up to 20%, (referring to the gas distributed in the network according to local standards in force) all calibration of the unit must refer to the O₂ values in the table above.



In addition to yearly maintenance, one must also check the energy efficiency of the thermal system, with frequency and procedures that comply with the indications of the technical regulations in force.



In the setting at Q. Nominal and at Q. Minimum, if the O₂ values are not reached, the Automatic Calibration procedure must be repeated. If after this operation the values are still not within the indicated ranges, no further adjustments are necessary.



In the case of an annual inspection of the device, the max CO must be less than 700 ppm (0% O₂). If the CO value is higher, the device requires maintenance/repair.

INSTALLER

USER

MAINTENANCE/TECHNICIAN

TECHNICAL DATA

3.4 HYDRAULIC DIAGRAM

INSTALLER

USER

MAINTENANCE TECHNICIAN

TECHNICAL DATA

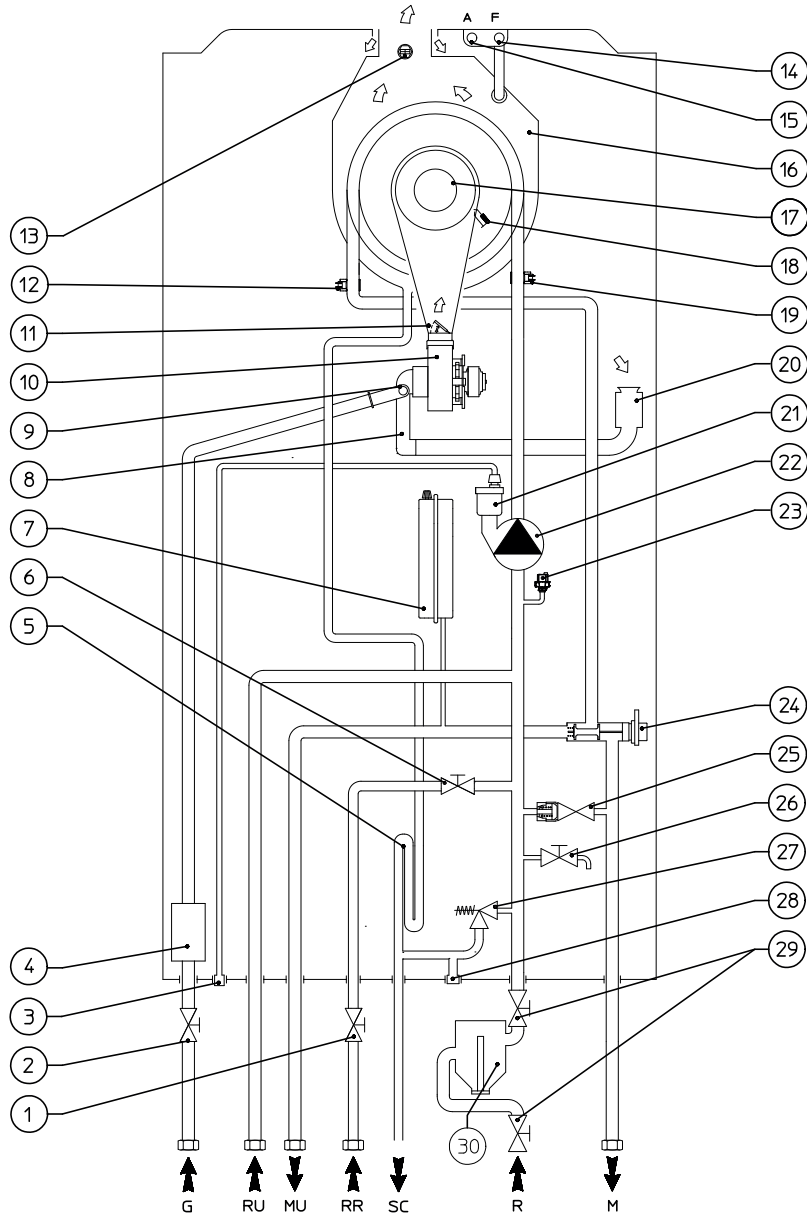

Key (Fig. 67):

- 1 - Cold water inlet valve
- 2 - Gas isolation valve
- 3 - Air vent valve drain
- 4 - Gas valve
- 5 - Condensate drain trap
- 6 - System filling valve
- 7 - System expansion vessel
- 8 - Air-gas mixer
- 9 - Gas diaphragm
- 10 - Fan
- 11 - Non-return valve on flue gas
- 12 - Module flow probe
- 13 - Double flue probe sensor

- 14 - Flue sample point (F)
- 15 - Air sample point (A)
- 16 - Condensation primary exchanger
- 17 - Burner
- 18 - Ignition-detection electrode
- 19 - Return probe
- 20 - Air intake pipe
- 21 - Air vent valve
- 22 - Appliance pump
- 23 - Pressure transducer
- 24 - Motorised 3-way valve
- 25 - By-pass
- 26 - System draining valve

- 27 - 3 bar safety valve
- 28 - 3 bar safety valve drain fitting signal
- 29 - Cyclonic filter assembly interception valves
- 30 - Cyclonic filter unit
- G - Gas supply
- RU - Storage tank unit return
- MU - Storage tank unit flow
- RR - System filling
- SC - Condensate drain
- M - System flow
- R - System return

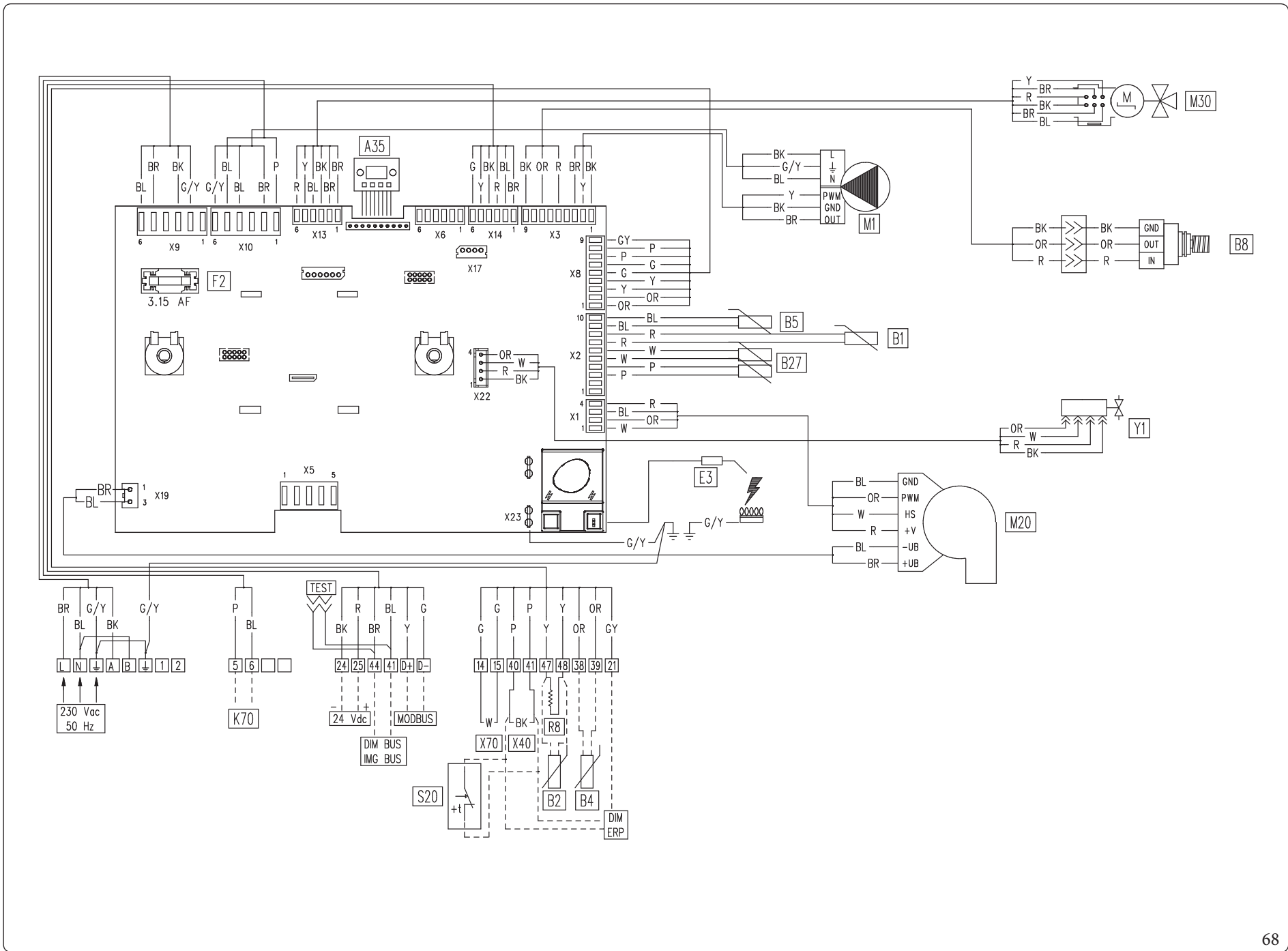

TECHNICAL DATA

MAINTENANCE TECHNICIAN

USER

INSTALLER

Key (Fig. 68):

A35	-	Touch keyboard
B1	-	Flow probe
B2	-	DHW probe (optional)
B4	-	External probe (optional)
B5	-	Return probe
B8	-	System pressure meter
B27	-	Double flue probe sensor
DIMBUS - DIMERP (optional) or Zone Kit		
E3	-	Ignition and detection electrode
IMG BUS - CAR v2 (optional) or Smartech Plus (optional) or Commercial Remote OT (optional)		
K70	-	Multifunction relay

MODBUS - Dominus (optional) or B.M.S.

M1	-	Boiler circulating pump
M20	-	Fan
M30	-	Three-way stepper motor
R8	-	Storage tank resistance
S20	-	Room thermostat (optional)
X40	-	Room thermostat link
X70	-	L.V. safety thermostat link
Y1	-	Gas valve

Colour code key (Fig. 68):

BK	-	Black
BL	-	Blue
BR	-	Brown
G	-	Green
GY	-	Grey
OR	-	Orange
P	-	Purple
R	-	Red
W	-	White
Y	-	Yellow
G/Y	-	Yellow/Green

Any room thermostat or ON-OFF must be connected to terminals 40 and 41 eliminating link X40.

Any CAR^{v2} must be connected to terminals 44 and 41 complying with the polarity **without eliminating link X40**.

Storage tank unit: the appliance is prepared for connection to a storage tank unit, which must be connected to clamps 36 and 37 of the terminal board (on the control panel), eliminating resistance R8.

3.6 REMOVABLE MEMORY



Replacing the memory must be carried out after disconnecting all electrical connection of the P.C.B.

P.C.B.

The P.C.B. is equipped with a removable memory (Ref. 2 Fig.69) which records all operation parameters and appliance customisations. Should the P.C.B. be replaced, you can use the memory of the replaced board again, so it is not necessary to reconfigure the appliance.

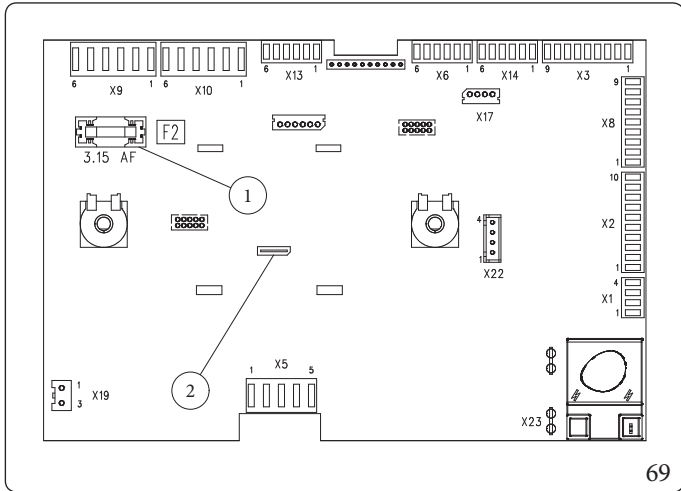

Key (Fig. 69):

- 1 - Quickfuse 3.15 250 V Type F
- 2 - Grey removable memory (A19)

INSTALLER

USER

MAINTENANCE/TECHNICIAN

TECHNICAL DATA

3.7 TROUBLESHOOTING



Maintenance operations must be carried out by an authorised company (e.g. Authorised After-Sales Technical Assistance Centre).

INSTALLER

USER

MAINTENANCE TECHNICIAN

TECHNICAL DATA

Trouble	Possible causes	Solutions
Smell of gas	Caused by leakage from gas circuit pipelines.	Check sealing efficiency of gas intake circuit.
Repeated ignition blocks	No gas. Condensate drain clogged.	Check the presence of pressure in the network and that the gas adduction valve is open. Restore the function of the condensate drain, checking that the condensate has not affected: combustion components, fan and gas valve.
Irregular combustion or noisiness	Dirty burner, clogged primary heat exchanger, incorrect combustion parameters, intake-exhaust terminal not correctly installed.	Check the indicated components.
Frequent trips of the overheating safety device thermostat function.	Lack of water in the appliance, little water circulation in the system or blocked pump (Parag. 1.36).	Check on the pressure gauge that the system pressure is within established limits. Check that the radiator valves are not closed and also the functionality of the pump.
Siphon blocked	Dirt or combustion products deposited inside.	Check that there are no residues of material blocking the flow of condensate.
Heat exchanger blocked.	This may be caused by the drain trap being blocked.	Check that there are no residues of material blocking the flow of condensate.
Abnormal noises in the system	Air in the system.	Make sure the system pressure and expansion tank factory-set pressure values are within the set limits. The factory-set pressure values of the expansion vessel must be 1bar (100 kPa), the value of system pressure must be between 1 and 1.2 bar.

3.8 CONVERTING THE APPLIANCE TO OTHER TYPES OF GAS



The gas conversion operation must be carried out by an authorised company (e.g. Authorised Technical Assistance Service).

For the gas change procedure, you must:

These adjustments must be made with reference to the type of gas used, following that given in the table (Parag. 4.2).

Checks following conversion to another type of gas.

After having made sure that the conversion is complete and that the calibration has been successful, you must make sure that:

- there is no flame in the combustion chamber;
- the burner flame is not too high or low and that it is stable (does not detach from burner);

SGV 100 B&P GAS valve

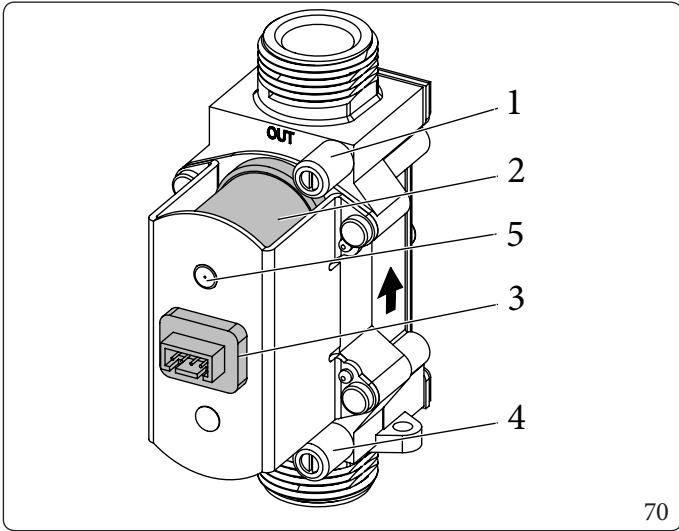

Key (Fig. 70):

- 1 - Gas valve outlet pressure point
- 2 - Coil
- 3 - Wiring connector
- 4 - Gas valve inlet pressure point
- 5 - P. Ref. (Reference pressure)



Risk of material damage after using sprays and liquids to search for leaks

Leak sprays and liquids clog the reference hole P.Ref. (Fig. 70) of the gas valve, damaging it irreparably.

During installation and maintenance, do not use spray or liquids in the upper area of the gas valve (electric connections side).

3.9 CALIBRATION TYPE INVOLVING THE REPLACEMENT OF A COMPONENT.

When performing extraordinary maintenance on the appliance, involving the replacement of a component, such as the P.C.B. (if the removable memory is not put into the replacement board) or components in the air, gas and flame control circuits, the appliance will need to be calibrated.

Select the type of calibration to be carried out according to the table below.

Component replaced	Type of calibration required
Gas valve	Automatic calibration
Fan	Automatic calibration
Burner	1) Automatic calibration 2 Possible manual calibration with verification of CO ₂ values
Ignition / detection electrode	1) Automatic calibration 2 Possible manual calibration with verification of CO ₂ values
P.C.B. (New virgin P.C.B. without removable memory recovery)	Reset the parameters 1) Automatic calibration 2 Possible manual calibration with verification of CO ₂ values
P.C.B. (Recovery of the removable memory with the boiler parameters set from the replaced board)	No calibration required.

3.10 AUTOMATIC CALIBRATION FUNCTION (TA)

This function allows you to calibrate the appliance automatically without the possibility of altering the parameters. "Automatic calibration" is used after the parameters have been changed or the components have been replaced (Parag. 3.9).

 Before carrying out automatic calibration, ensure that all the requirements indicated in (Parag. 1.32 - 1.33).

If you want to dissipate the entire energy on domestic hot water (if combined with a storage tank unit), set the DHW setting to maximum. Then activate the "automatic calibration" function and open a hot water tap.

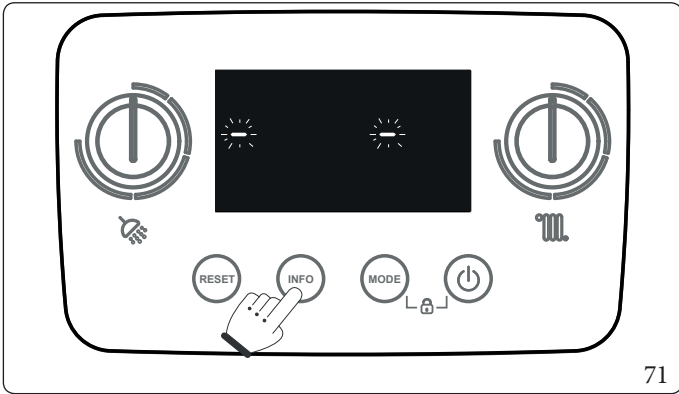

The function can be activated from the Special Functions menu by selecting "tA".

If OFF or Stand-by mode is selected, the function cannot be activated.

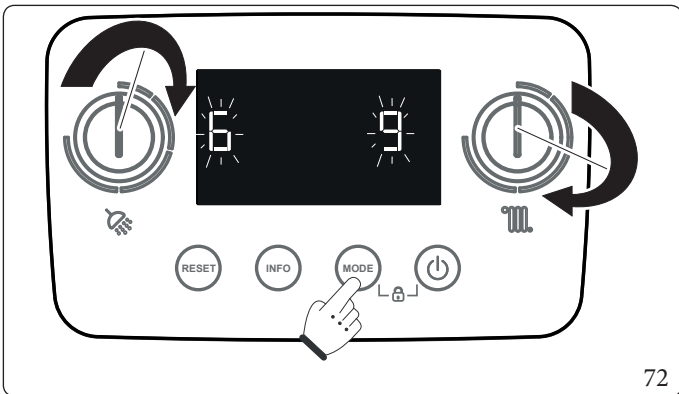

To access the automatic calibration function, the "INFO" button must be pressed and held down for longer than 5 seconds; two single flashing "-" dashes appear on the display and the password () for access to the programming menus must be entered.



To enter the left digit use the knob (5) for adjusting the domestic hot water temperature (), to enter the right digit use the knob (6) for adjusting the central heating temperature (). Press MODE to confirm the password.

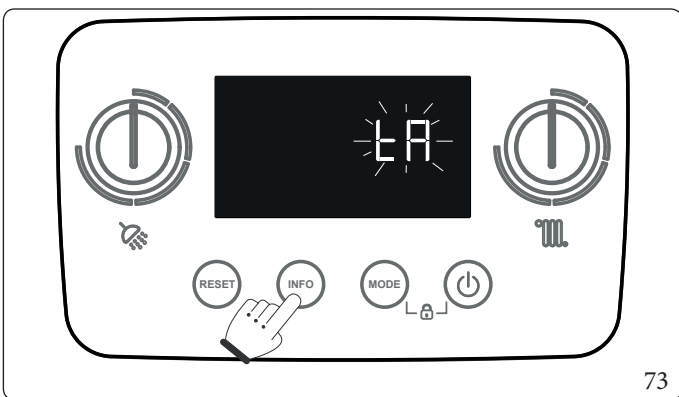

Once in the menu, press INFO until the flashing "tA" appears. Confirm by pressing MODE.

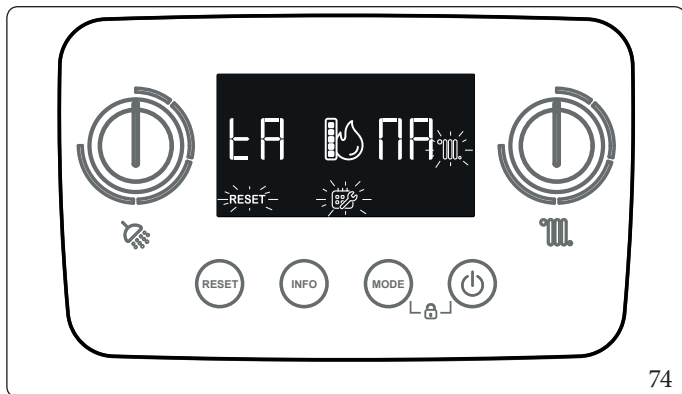

Once the function is activated, the service symbol (🔥) will start flashing. The digits on the left will display "tA" while those on the right will display the flow temperature alternating with the indication (MA, AC, Mi) of the current phase, depending on the progress of the calibration.

- (MA): Nominal heat output calibration;
- (AC): Intermediate heat output ignition calibration;
- (Mi): Minimum heat output calibration.

The flashing (🔥) or (🔥) symbols indicate on which circuit the energy produced during calibration is being dissipated. Pressing the Reset button allows you to exit the function in advance.

The calibration function ends automatically by returning the appliance to the state it was in before it was activated. No interaction with the device is necessary: the function is fully automatic.

3.11 MANUAL CALIBRATION FUNCTION (TM)



Before carrying out manual calibration, ensure that all the requirements indicated in (Parag. 1.32 and 1.33) are met.

Manual calibration should **only** be done to slightly correct CO₂ values **after automatic calibration**.

During the various calibration steps, it is possible to check the correct CO₂ value and, if necessary, correct it to obtain the values indicated in Parag. 3.3.

The energy produced during the function is disposed of on the central heating circuit / C.H. circuit if a DHW (Domestic hot water) request is not activated; check that any valves on the system not managed by the appliance are open.

If you want to dissipate the entire energy on domestic hot water, set the DHW set to maximum. Then activate the function and open a hot water tap.

The calibration procedure involves various stages:

- Rated power calibration (MA);
- Calibration of intermediate ignition power (AC);
- Minimum power calibration (Mi).

When the function is completed or when the 15-minute timer expires, the function terminates, returning to its starting state.

Manual calibration activation.

The function can be activated from the Special Functions menu (Parag. 3.14) by selecting "tM".

If OFF and Stand-by mode is selected, the function cannot be activated.

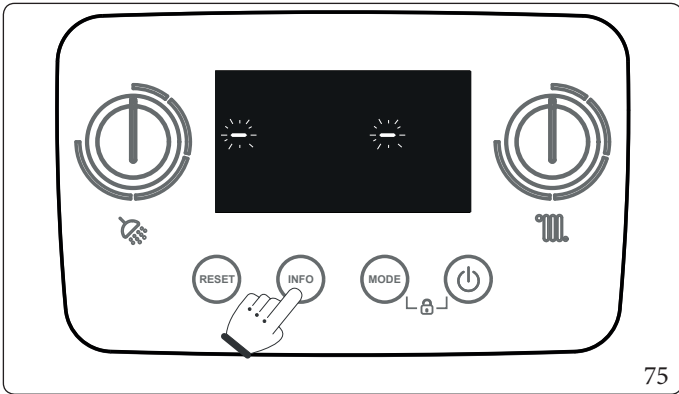

To access the programming phase, press and hold the "MODE" and "RESET" buttons for more than 5 seconds; the display shows two dashes "-" single blinks and you must enter the password (69) to access the programming menus.

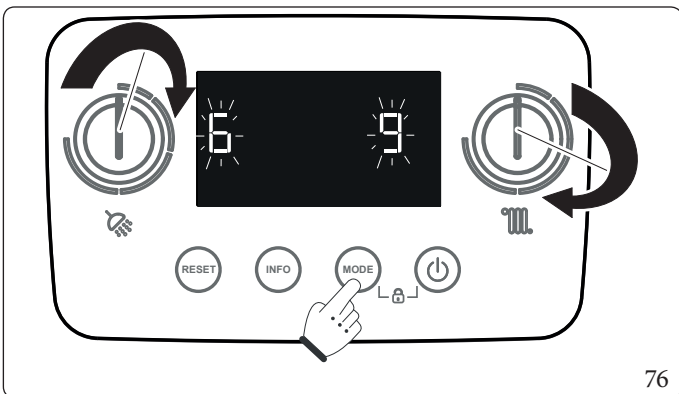

To enter the left digit use the knob (5) for adjusting the domestic hot water temperature (5), to enter the right digit use the knob (6) for adjusting the central heating temperature (6). Press MODE to confirm the password.

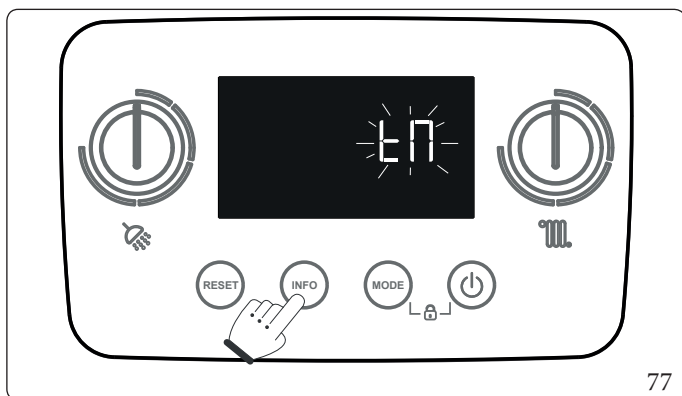

77

Once in the menu, press INFO until the flashing "tM" appears. Confirm by pressing MODE.

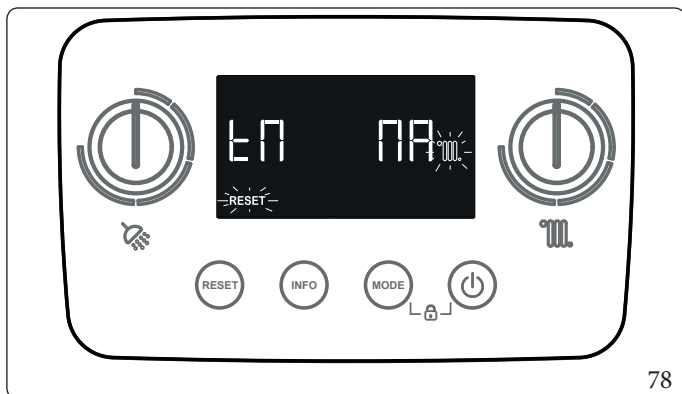

78

Once the function is activated, the service symbol (🔥) will start flashing. The digits on the left will display "tM" while those on the right will display the flow temperature alternating with the indication (MA, AC, Mi) of the current phase.

The flashing (🔥) or (🔥) symbols indicate on which circuit the energy produced during calibration is being dissipated.

Once the boiler is switched on, the symbol (🔥) will appear flashing.

Pressing the Reset button allows you to exit the function in advance.

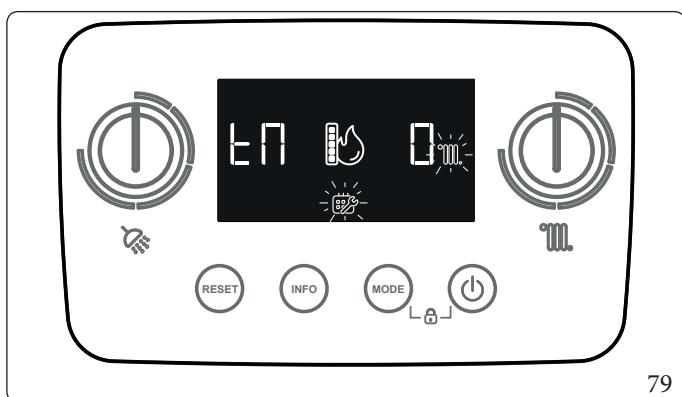

79

Once the system has stabilised and reached the flame set for the current phase, the symbol (🔥) becomes fixed and "0" appears on the right digit.



Under these conditions, the combustion value (CO₂) related to the delivery of maximum rated power (MA), intermediate ignition (Ac) and minimum ignition (Mi) can be measured

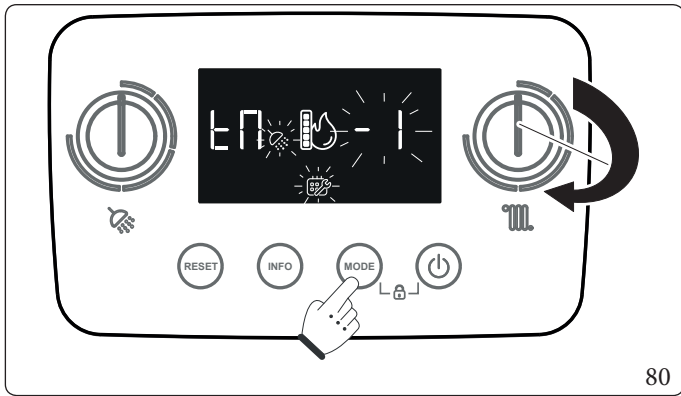

80

You may then:

- proceed to the next calibration step by pressing MODE;
- **(ONLY IF NECESSARY)** change the value of the flame set to correct the CO₂ value. (Increase the flame set value to decrease the CO₂ value). Use the knob (6) to adjust the heating temperature (°C) by selecting a value between -1, 0 and 1 (the edited value will flash). Confirm the value by pressing the MODE button (the symbol (🔥)) will start flashing and the indication (MA, AC, Mi) of the current phase alternating with the flow temperature will appear again on the right digit).

When the new flame set is reached, the symbol (🔥) will become steady again and the previously set value will be displayed on the right digit. It is possible to move on to the next stage by pressing the MODE button or to make a further correction by decreasing or increasing the flame set value by a further unit (up to a maximum of -5 - +5) in the same way. The procedure will end either automatically at the end of the maximum time or by pressing the MODE button on completion of the last calibration step (Mi) with digit flashing to confirm successful calibration. To exit early, press the RESET button.

INSTALLER

USER

MAINTENANCE/TECHNICIAN

TECHNICAL DATA

3.12 FLUE TEST



Before performing the test, ensure that the condensate drain trap has been filled correctly and check that there are no obstructions in the air intake circuit and flue exhaust and that the sealed chamber is perfectly closed and the flue has already been installed.

In the event of anomaly "62" or "72" (Parag. 2.5) :in these cases, automatic calibration is required

This test makes it possible to assess and if necessary adjust the fan speed according to the length of the installed flue.

To carry out the Flue Test, activate the flue test function FU in the special functions menu (Parag.3.14 and 3.18).

To define the value to be set in parameter "F.0" carry out the ΔP measurement during the "Flue Test".

Check the ΔP between the two pressure points of the flue gas sampling cap (Parag. 1.38) , note the value in the space provided in the table below and set parameter "F.0" according to the values shown below:

VICTRIX MAIOR 35 PLUS	
Parameter F0	Pressure
0	≤ 173 Pa
1	> 173 Pa
2	> 228 Pa
Value detected on first check	

The function ends after 15 minutes, or by pressing Reset.



This procedure must not be carried out in the case of installation $C_{(10)} - C_{(12)}$. In that case, parameter F.0 = 0 must be left and parameter F.1 = 1 set.



Examinations are carried out by sealing the holes provided to analyse the flues, making them pneumatically sealed.



Should there be a appliance malfunction, you can carry out a flue test to check that there are no obstructions in the flue system. Different values to those indicated in the previous tables indicate a flue system malfunction, especially a flue system with excessive load losses or obstructed system.

3.13 P.C.B. PROGRAMMING

The device is prepared for possible programming of several operation parameters.

By modifying these parameters as described below, the device can be adapted according to specific needs.

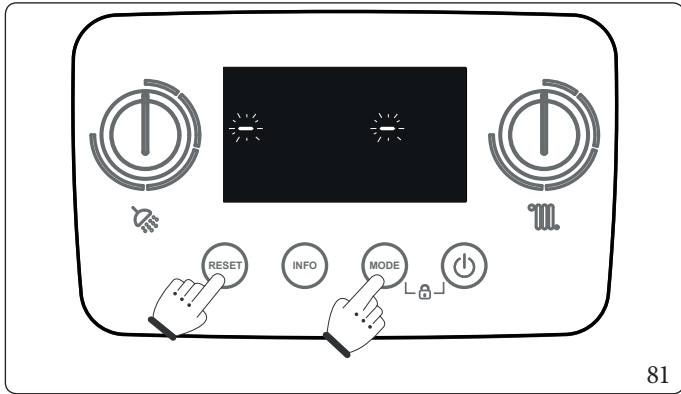

81

To access the programming phase, press and hold the "MODE" and "RESET" buttons for more than 5 seconds; the display shows two dashes "-" single blinks and you must enter the password (🔑) to access the programming menus.

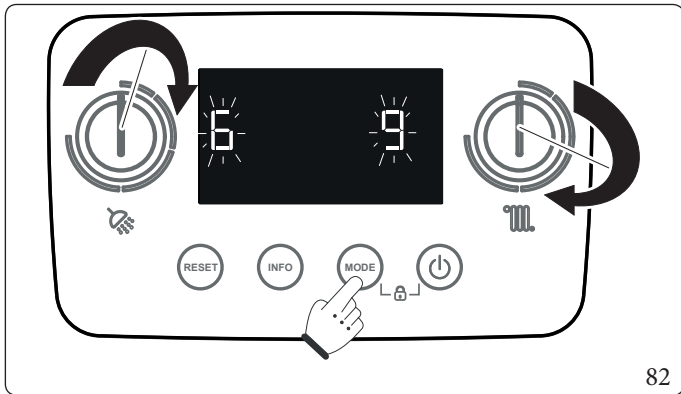

82

To enter the left digit use the knob for adjusting the domestic hot water temperature (🔥), to enter the right digit use the knob for adjusting the central heating temperature (🏠). Press MODE to confirm the password.

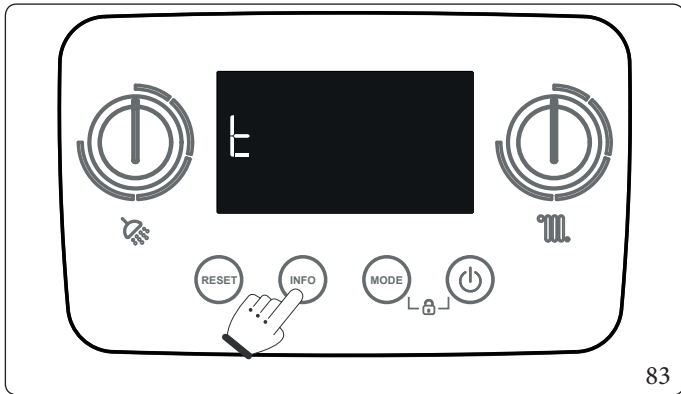

83

Once you have entered the menu, the family of parameters is displayed.

Press "INFO" to scroll the list of parameter families.

Scrolling through the list of parameter families occurs in a circular mode: G→P→t→A→G→P→...

Once you have selected the required family (E.g. t), press "MODE" to confirm and enter in the family.

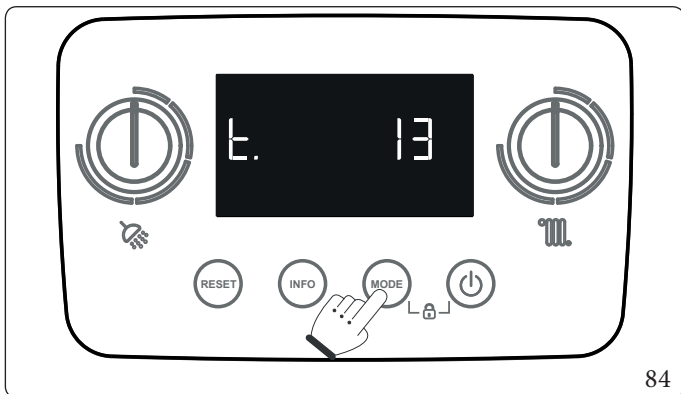

84

Once you have entered in the family, press "INFO" to scroll the list of parameters and select the required one (E.g. t.13). Then press "MODE" to confirm and view the value.

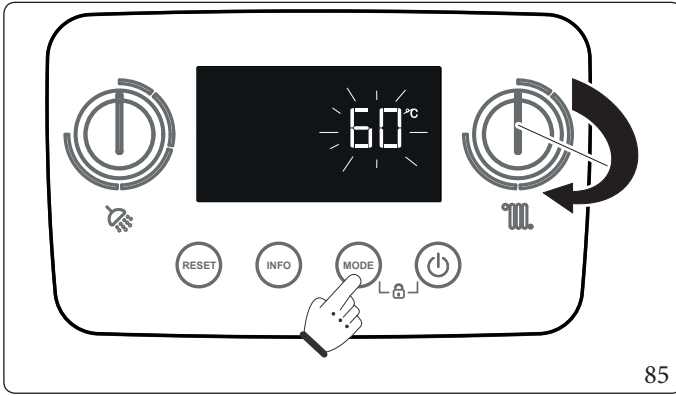

If the parameter can be adjusted, it activates the option to adjust via the knob to set the C.H. temperature (🌀). If the settable value has a very wide range, the control knob for the DHW temperature (🌀) will also be active for a rough adjustment.

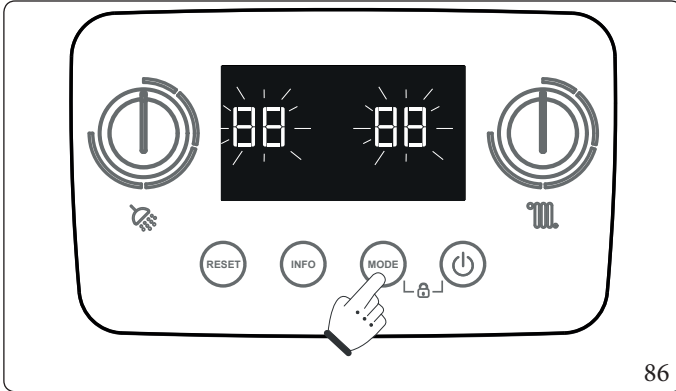

After editing, the new value can be saved by pressing "MODE". The text "88 88" will flash to confirm that the value has been saved.

Pressing RESET, as well as the expiry of the 15-minute time-out, exits the configuration menu.

Programming phase sequence.

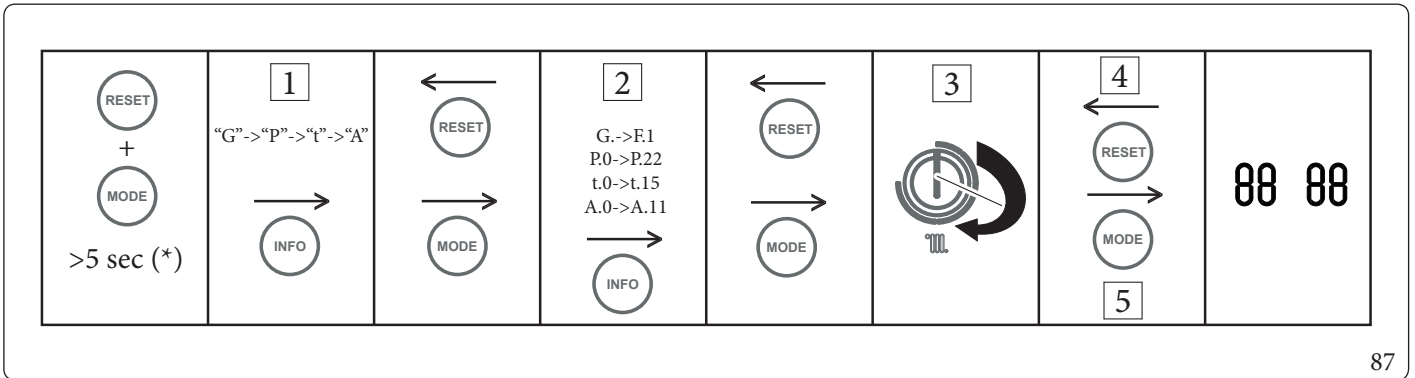

Key (Fig. 87):

- 1 - Parameter family selection
- 2 - Parameter selection
- 3 - Change parameter value
- 4 - Without memorising
- 5 - Store
- (*) - Seconds

List of G family parameters.

To enter in the parameters of the family G, press "MODE" with G on the display. "G." will appear. Press "INFO" to scroll the submenus of the G family.

Id Parameter	Parameter	Description	Range	Default	Customised value
G.	Gas type	Display gas type: nG (Methane) or LG (LPG)	nG-LG-AP	nG	
n.	Boiler model	Define the boiler model	0-20*	1	
S.0	Minimum no. of fan revs	Defines the operating speed of the fan at minimum output. Use both knobs 5 and 6 for adjustment.	700-3000	2200	
S.1	Maximum no. of fan revs	Defines the operating speed of the fan at maximum output. Use both knobs 5 and 6 for adjustment.	2000-8300	7200	
S.2	Ignition phase no. of fan revs	Defines the operating speed of the fan during the ignition phase. Use both knobs 5 and 6 for adjustment.	2000-4500	3800	
F.0	Flue length composition	Increases the fan speed by defined values to compensate for the length of the flue (Parag. 3.12).	0-2	0	
F.1	Presence of clapet valve on flue gas (C ₍₁₀₎ - C ₍₁₂₎)	If present, automatic corrections are made to the fan's operating range	0-1	0	

*: 0 cannot be used; from 4 to 20 cannot be used; only 1-2-3 available.



If parameters are changed, the anomalies "E62" or "E72" will appear and automatic calibration will be required.

INSTALLER

USER

MAINTENANCE/TECHNICIAN

TECHNICAL DATA

List of P family parameters.

To enter in the parameters of the family P, press "MODE" with P on the display. P.0' will appear.

Press "INFO" to scroll the submenus of the P family.

Id Parameter	Parameter	Description	Range	Default	Value customized
P.0	DHW max	Defines the maximum heat output percentage of the boiler during the D.H.W. phase compared to the maximum heat output available	0-100	100	
P.1	Min C.H.	Defines the minimum output percentage of the boiler in central heating mode	0-100	0	
P.2	Central heating max	Defines the minimum output percentage of the boiler in central heating mode	0-100	96	
P.3	Pump functioning	The pump can operate in two modes. 0: intermittent: in "Central heating only" or "DHW + CH" mode the pump is controlled by the room thermostat or remote control. 1: continuous: in "Central heating only" or "DHW + CH" mode the pump is always energised and therefore always running.	0-1	0	
P.4	On-board relays (5-6)	0: OFF 1: Zone 1 2 control: Zone 2 3 control: Alarm 4: Not used 5: Not used 6: CH mode active 7: Not used 8: External system 3-way valve 9: Boiler pump 10: Remote activation Chiller 11: Storage tank recirculation 12: Not used	0-12	0	
P.5	Relay 1 on relay board (Optional)	0: OFF 1: Zone 1 2 control: Zone 2 3 control: Alarm 4: Not used 5: Not used 6: CH mode active 7: Not used 8: External system 3-way valve 9: Boiler pump 10: Remote activation Chiller 11: Storage tank recirculation	0-12	0	
P.6	Relay 2 on relay board (Optional)	See notes P.5	0-11	0	
P.7	Relay 3 on relay board (Optional)	See notes P.5	0-11	0	

For parameters P.4, P.5, P.6 and P.7, with the relay already set with a value other than zero, the others do not accept the same configuration.

Id Parameter	Parameter	Description	Range	Default	Value customized
P.8	Stand-by/OFF configuration	0: Antifreeze, anti-blockactive 1: Antifreeze off and anti-blockactive 2: Antifreeze anti-block off 3: Not used	0-3	0	
P.9	External probe reading correction	If the reading of the external probe is not correct it is possible to correct it in order to compensate any environmental factors.	-9..9 (K)	0	
P.10	Not used	-	-	-	
P.11	Configuration Input 1 (40-41)	Setting a value other than zero is not accepted if the function is already present in another input (*): 0: OFF 1: zone 1 room thermostat generates central heating request together with remote control (logic in AND) 2: room thermostat zone 1 generates a heating central heating request as an alternative to the remote control (Logic in OR) 3: room thermostat zone 2 generates a heating central heating request as an alternative to the remote control (Logic in OR) 4: Safety thermostat (low temperature)	0-4	1	
P.12	Configuration Input 2 (14-15)	See notes P.11	0-4	4	
P.13	Configuration Input 3 (1-2)	Not used	-	-	
P.14	ImgBus Input Configuration (44-41)	Setting a value other than zero and one is not accepted if already present in another input: 0: Not used 1: ImgBus 2: TA zone 1 3: TA zone 2 4: Safety thermostat (low temperature)	0-4	1	
P.15	Probe configuration (47-48)	0: OFF/Storage tank probe 1: Not available 2: Not available	0-2	The value is automatically selected depending on the value set in parameter A.0	

(*): when connecting a DIM or zones control unit to terminals 21, 40 and 41, parameter P.11 must be set at 2.

INSTALLER

USER

MAINTENANCE/TECHNICIAN

TECHNICAL DATA

Id Parameter	Parameter	Description	Range	Default	Value customized
P.16	Scheduled maintenance Service	Set the value in months at scheduled maintenance. When the months set on the boiler display have expired, the icon () appears while error 97 is displayed on the remote control CAR ^{v2} . Boiler operation is still guaranteed. To reset the warning, set parameter P.16 at '0'; then you may set a new month interval for the next scheduled maintenance.	0-36	0	
P.17	Terminals 44-41 communication protocol	Set the dialogue protocol available on terminals 44-41 0: IMG BUS/DIMBUS. Select this mode when connecting an Immergas remote control (e.g.: CAR ^{v2} or a DIM) to terminals 44/41 1: Select this mode when a commercial remote control is connected to terminals 44-41 (with this selection, the control of the domestic hot water adjustments and max set central heating flow remains available on the boiler panel)	0-1	0	
P.18	Modbus Protocol (D+/D-)	Modbus port setting: 0: Off 1: Dominus 2: BMS	0-2	0	
P.19	Slave Address (for BMS)	Node id (slave address)	1 ÷ 247	1	
P.20	Baud rate (for BMS)	0=1200 1=2400 2=4800 3=9600 4=19200 5=34800	0-5	3	
P.21	Stop bit (for BMS)	Set the number of Stop bits	1 ÷ 2	1	
P.22	Parity bit (for BMS)	0: None 1: Even 2: Odd	0-2	1	

List of t family parameters.

To enter in the parameters of the family t, press "MODE" with t on the display. t.0' will appear.

Press "INFO" to scroll the submenus of the t family.

Id Parameter	Parameter	Description	Range	Default	Value customized
t.0	Central heating set point minimum temperature	Set minimum central heating / C.H. set limit available	20..(t.1-5) (20-50)	20	
t.1	Central heating set point maximum temperature	Set maximum central heating / C.H. set limit available	(t.0+5)..85 (25-85)	85	
t.2	Boost Mode (DHW Recirculation Function Par. 2.4)	0: Always off 1: Always ON 2: Auto	0-2	0	
t.3	Solar Delay timing	Not used	-	-	
t.4	Domestic hot water priority timer	Not used	-	-	
t.5	Central heating ignitions timer	The boiler has an electronic timer, which prevents the burner from igniting too often in central heating mode.	0-600 seconds	180	
t.6	Heating ramp timing	In central heating mode, the boiler performs an ignition ramp in order to reach the maximum output set.	0-840 seconds	180	
t.7	Heating switch-on delay request from room thermostat or remote control	The boiler is set to switch-on immediately after a request. In the event of particular systems (e.g. area systems with motorised thermostatic valves etc.) it may be necessary to delay ignition.	0-600 seconds	0	

INSTALLER

USER

MAINTENANCE/TECHNICIAN

TECHNICAL DATA

Id Parameter	Parameter	Description	Range	Default	Value customized
t.8	Display lighting	Establishes the display lighting mode. 0: the display lights up during use and lowers after 15 seconds of inactivity. In the case of anomaly the display remains at maximum lighting. 1: display lighting always low. 2: display lighting always high.	0-2	0	
t.9	Display	(see next table)	0-2	2	
t.10	Low lighting level	Backlight brightness in low mode in %	0 ÷ 100	20	
t.11	Buzzer sound level	Buzzer noise level in %	0 ÷ 100	100	
t.12	DHW set point minimum temperature	Set minimum DHW (Domestic hot water) set limit available to user	$10 \div (t.13-5)$	10	
t.13	DHW set point maximum temperature	Set maximum DHW (Domestic hot water) set limit available to user	$(t.12+5) \div 65$	60	
t.14	Not used	-	-	-	
t.15	Flow off temperature increase	Increases the flow Off temperature at ignition only in the first 60 seconds. After flame signal detection, the temperature is increased by T.15 (to avoid On/Off on direct systems with little water)	0-15	10	

Main display based on parameter t.9.

OPERATION MODE	DISPLAY CONFIGURATION (t9)	DHW	CENTRAL HEATING
DHW ONLY	0	always off	always off
	1	<u>pump in DHW ON</u> : displays the flow temperature <u>pump OFF</u> : displays the DHW set-point	always off
	2	always displays the DHW set-point	always off
CENTRAL HEATING ONLY	0	always off	always displays the central heating set-point
	1	always off	<u>pump in central heating ON</u> : displays the flow temperature <u>pump OFF</u> : displays the central heating set-point
	2	always off	always displays the central heating set-point
DHW + C.H.	0	always off	always displays the central heating set-point
	1	<u>pump in DHW ON</u> : displays the flow temperature <u>pump OFF</u> : displays the DHW set-point	<u>pump in central heating ON</u> : displays the flow temperature <u>pump OFF</u> : displays the central heating set-point
	2	always displays the DHW set-point	always displays the central heating set-point

INSTALLER

USER

MAINTENANCE TECHNICIAN

TECHNICAL DATA

List of A family parameters.

To enter in the parameters of the family A, press "MODE" with A on the display. A.0' will appear. Press "INFO" to scroll the submenus of the A family.

Id Parameter	Parameter	Description	Range	Default	Value customized
A.0	DHW hydraulic selection	0: Instantaneous 1: Instantaneous with flow rate regulator 2: Storage tank 3: Instantaneous with Aquaceleris	0-3	2	
A.1	Not used	-	-	-	
A.2	Maximum pump speed	Defines the maximum operating speed of the pump during central heating requests (If A2 = A3 pump operating at set speed).	A.3-9	9	
A.3	Minimum pump speed	Defines the minimum pump operating speed during central heating requests. It is recommended not to enter values lower than 6	1-A.2	6	
A.4	Circulating pump mode	Defines the pump operating mode during central heating requests: - $\Delta T=0$: proportional head (Parag. 1.36); - $\Delta T=5\div 25K$: ΔT constant (Parag. 1.36).	0-25	15	
A.5	DHW flow offset (storage tank only)	The temperature value that the board adds to the DHW set point to determine the cylinder coil flow temperature	0-25	25	
A.6	DHW hysteresis (storage tank only)	The temperature difference compared to the set DHW set-point which determines the activation of the DHW priority function	0-15	10	
A.7	Not used	-	-	-	
A.8	System automatic vent	Enables the automatic vent function. This function is activated every time the appliance is powered again 0: disabled 1: enabled	0-1	1	
A.9	Pressure sensor / pressure switch selection	Selects the system pressure detection mode: 0: Pressure sensor 1: Not used	0-1	0	
A.10	System pressure minimum value	Value below which fault "E10" (insufficient system pressure) is detected, in bar	0.0..1.2	0.4	
A.11	Maximum system pressure value	Value above which the fault "E146" (System pressure too high) is detected, in bar	1.5..3.5	3	

3.14 PASSWORD-PROTECTED SPECIAL FUNCTIONS



The appliance is equipped with some special functions. Access to some of these is only permitted by specific operating modes.

If the boiler is in DHW Only, CH Only, DHW + CH or Remote Control Stand-by mode, the following functions are available:

- dI (Automatic Venting Function);
- Fu (Flue Function);
- tA (Automatic Calibration Function);
- tM (Manual Calibration Function).

If the boiler is in Off mode from the boiler control panel, the following functions are available:

- SM (Screed Heater Function);
- MA (Maintenance Function);
- dI (Automatic Venting Function);
- Fu (Flue Function).



If the appliance is connected to the CARv2, the "stand-by" function is only obtained via the remote control panel.

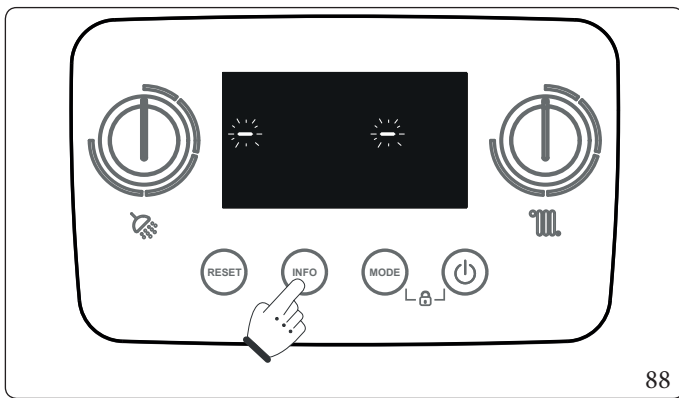

88

Press and hold the "INFO" button for more than 5 seconds. Two flashing single "-" lines appear on the display. Now enter the password (5 6) to access the programming menus.

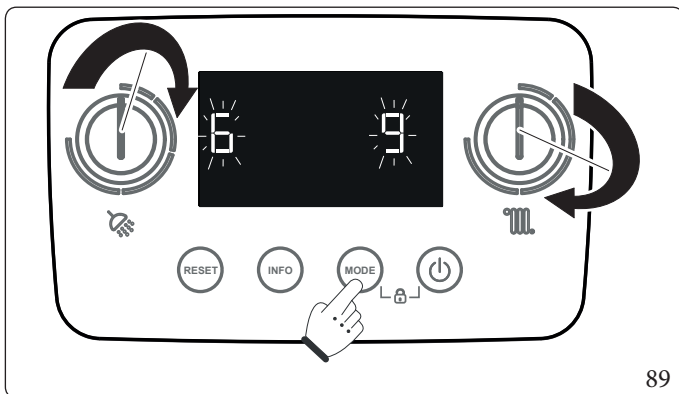

89

To enter the left digit use the knob (5) for adjusting the domestic hot water temperature (5), to enter the right digit use the knob (6) for adjusting the central heating temperature (6). Press MODE to confirm the password.

Once you have entered the menu, you can cycle through the following available functions by pressing the "INFO" button:

- Screed heater (SM): only visible when the boiler is OFF;
- Maintenance (MA): visible only with boiler OFF;
- Automatic venting (dI);
- Flue (Fu);
- Automatic calibration (tA): only visible when the boiler is NOT in OFF;
- Manual calibration (tM): only visible when the boiler is NOT in OFF.

To select the function press the "MODE" button; to exit wait for the automatic end of the activated function or press the "RESET" button.

3.15 SCREED HEATER

The function can be activated from the Special Functions menu by selecting "SM".

It is a function to perform the thermal shock on new radiant panel systems, as required by the applicable standard. Allows to set the system flow temperature at a lower or higher setpoint to be able to perform the thermal shock of the screed respectively for 3 and/or 4 days.



Contact the manufacturer of the radiant panels for the thermal shock characteristics and its correct execution.



To be able to activate the function there must be no remote control connected, while in case of system divided into zones it must be properly connected, both hydraulically and electrically.



The function can only be activated if the device is Off.

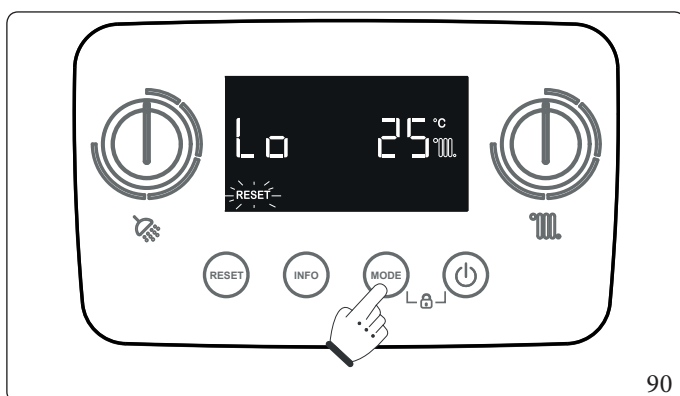

By activating the function, the lower temperature set appears (default 25°C, range 20 - 45°C) which can be edited by acting on the knob for adjusting the system temperature (°C), and finally confirmed by pressing the "MODE" button. The adjusted set flashes 2 seconds after the last time a key was pressed.

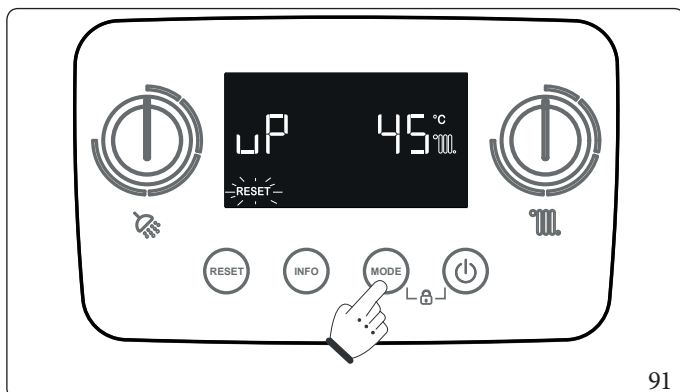

After confirming the first set, the upper temperature set is displayed (default 45°C, range 25 - 50°C), which can be edited in the same way. Confirmation by pressing "MODE" will save the value and the Screed Heater is activated.

If no key is pressed for 2 minutes during these temperature selections, the function is abandoned and the appliance goes back into standby.

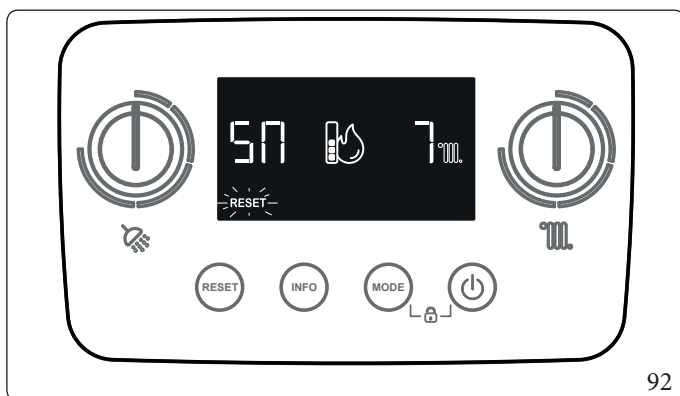

When the function is active, the display alternately shows the countdown of the days and the current flow temperature, at the same time as the normal operating information (flame symbol, faults).

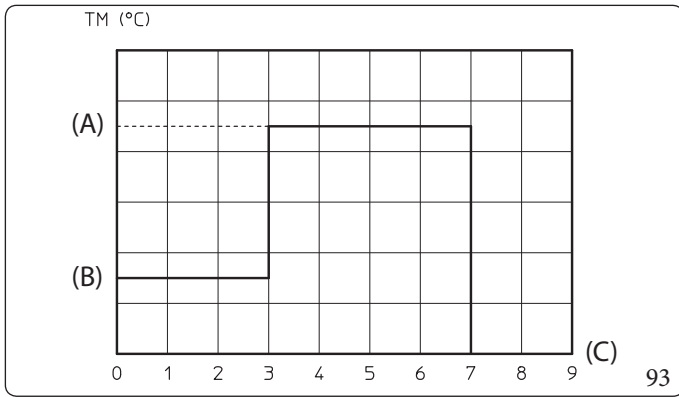

Key (Fig. 93):
 (A) - Top set
 (B) - Lower set
 (C) - Days
 TM - Flow temperature

The function lasts in total 7 days, 3 days at the lower temperature set and 4 days at the higher temperature set (Fig. 93).
 When the function is active, the current flow temperature is displayed (read by the flow probe) alternating with the countdown of the days remaining until the end (7, 6, 5, etc.). In addition, the symbol $\text{°}\text{C}$ (indicating the disposal of heat to the heating system) and the symbol **RESET** (indicating the possible forced termination of the function by pressing the RESET button) are displayed in flashing mode.
 In case of failure or lack of supply voltage, the function is suspended and will resume when the normal operating conditions are reset from the point where it was interrupted.
 When the time expires, the boiler automatically goes back to "Stand-by" mode, the function can also be stopped by pressing the "RESET".

INSTALLER

USER

MAINTENANCE/TECHNICIAN

TECHNICAL DATA

3.16 MAINTENANCE FUNCTION (MA)

The function can be activated from the Special Functions menu by selecting 'MA'.

Using this function, you can activate some operating devices of the appliance without starting it, thus verifying operation.

The function is active for 15 minutes and it can be stopped by pressing the "RESET" button.

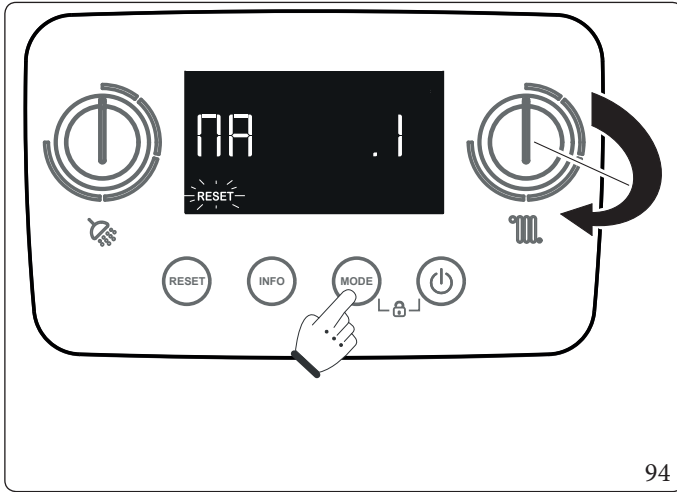

With "MA" displayed by the special functions list, press "MODE" to enter the "Maintenance" menu. The various items of the "Maintenance" menu would then be available (see table below). You may scroll the menu to select the items by pressing the "INFO" button. Once you have identified the menu item to be used, press "MODE" to confirm. Then use the heating temperature adjustment knob (°) to set the value for the required forcing. Lastly, press MODE to activate forcing.

94

Id Parameter	Parameter	Description	Range
MA.0	Permanent spark	0: OFF 1: spark always ON (without gas intake)	0 ÷ 1
MA.1	Permanent fan	0: OFF >0: fan on (without gas intake)	0 ÷ 100 %
MA.2	Permanent pump	0: OFF >0: pump ON (without gas intake)	0 ÷ 100 %
MA.3	3-way forcing	0: OFF 1: system position 2: DHW position 3: intermediate position	0 ÷ 3
MA.4	Not used	-	-
MA.5	Board relay forcing	0: OFF 1: energised relay	0 ÷ 1
MA.6	Forcing relay 1 on relay board (optional)	0: OFF 1: energised relay	0 ÷ 1
MA.7	Forcing relay 2 on relay board (optional)	0: OFF 1: energised relay	0 ÷ 1
MA.8	Forcing relay 3 on relay board (optional)	0: OFF 1: energised relay	0 ÷ 1

3.17 AUTOMATIC VENT FUNCTION (DL)

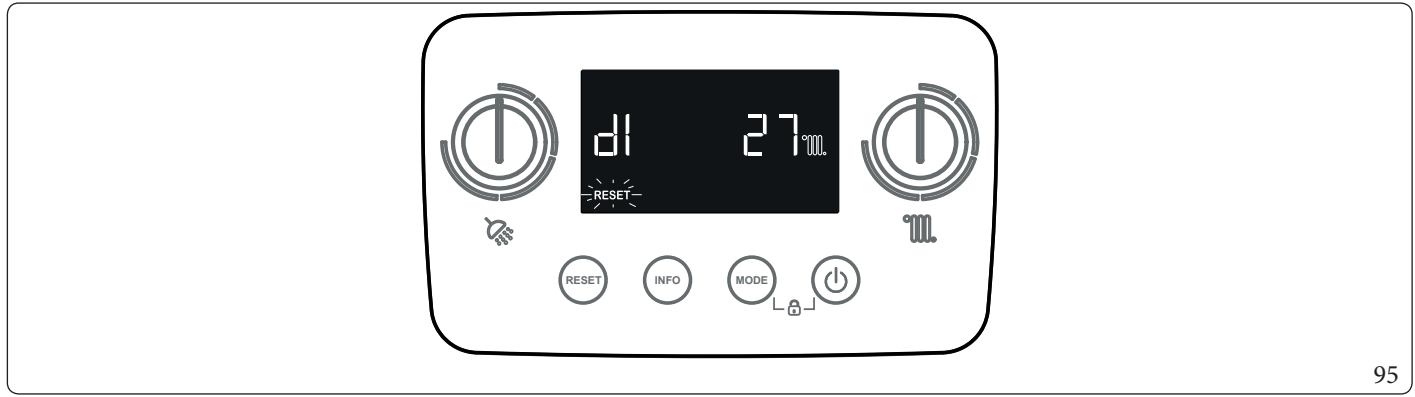

In the case of new central heating systems and in particular mode for floor systems, it is very important that deaeration is performed correctly.

The function consists of the cyclic activation of the pump and the 3-way valve (both in DHW and CH position).

By default, the function activates automatically for 10 minutes when the boiler is powered on.

This automatic activation can be disabled by setting parameter A.8=0.

The function can be activated manually by entering the special functions as described in Paragraph 3.14 and selecting "dl". In this case, it has a duration of 16.5 hours.

When it has activated, the indication "dl" appears on the DHW digits and the time remaining until the end of the function in tenths of minutes appears on the CH digits.

The display of the symbols (☼) and (⌋) indicates whether the function is active in domestic hot water or central heating mode.

When the function has ended, the boiler automatically goes back to the initial status. The flashing "RESET" symbol (yellow) indicates the option to stop the function in advance by pressing the relative key.

3.18 FLUE INSTALLATION (FU)

To activate the "Flue" function access the special functions as described in Paragraph 3.14 and select the "FU" function.



Before performing the test, ensure that the condensate drain trap has been filled correctly and check that there are no obstructions in the air intake circuit and flue exhaust and that the sealed chamber is perfectly closed and the flue has already been installed.

Using this function activates the fan at a fixed speed (5500 rpm) for 15 minutes.

At this stage, the symbol "RESET" flashes on the display; it is possible to interrupt the function by simply pressing the 'RESET' button.

3.19 CHIMNEY SWEEP

This function, when activated, forces the boiler to a settable power for 15 minutes. In this state all adjustments are excluded and only the safety thermostat and the limit thermostat remain active.

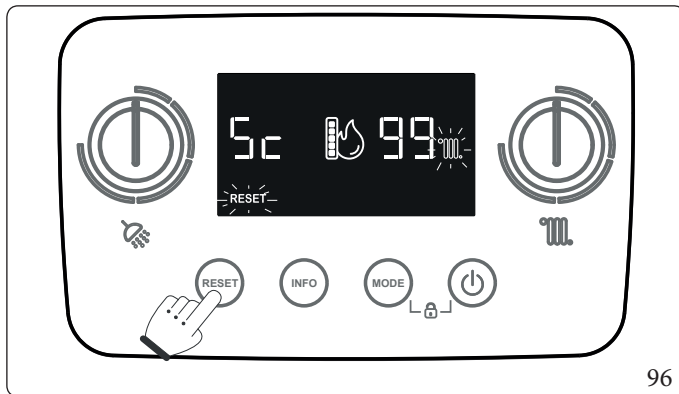

To activate the chimney sweep function, press the "RESET" button for 5 seconds if there are no DHW requests.

This function allows the technician to check the combustion parameters.

Once the function is activated, it is possible to select whether to make the check in CH status or DHW status by opening any hot water valve.

If the function is active in CH mode, the knob for setting the CH temperature (°C) can be used to select the power from Minimum Power (0%) to Maximum Heating Power (99%) in 1% intervals. If the function is active in DHW mode, the knob for setting the CH temperature (°C) can be used to select the power from minimum power (0%) to maximum DHW power (99%) in 1% intervals.

Functioning in CH or DHW mode is visualised by the relative flashing symbols "⌘" or "⌘".

To exit, press the RESET button.

3.20 PUMP ANTI-BLOCK

The appliance has a function that starts up the pump at least once every 24 hours for 30 seconds in order to reduce the risk of the pump locking up due to prolonged inactivity.

When "OFF" operating status is selected, this function can be deactivated by means of the parameter P.8.

3.21 THREE-WAY ANTI-BLOCK

The appliance has a function that activates the motorised 3-way unit 24 hours after the last time it operated by running a complete cycle in order to reduce the risk of the 3-way blocking due to prolonged inactivity.

When "OFF" operating status is selected, this function can be deactivated by means of the parameter P.8.

3.22 RADIATOR ANTIFREEZE

If the system return water is below 4°C, the appliance starts up until reaching 42°C.

When "OFF" operating status is selected, this function can be deactivated by means of the parameter P.8.

3.23 CASINGREMOVAL

To facilitate appliance maintenance the casing can be completely removed as follows:

Lower grid (Fig. 97)

- Loosen the two screws (a);
- Press the hooks inwards, which block the lower grid (b).
- Remove the grid (b).

Front casing (Fig. 98)

- Loosen the screws (c).
- Pull the front casing (c) towards yourself from the bottom edge to release it from the control panel.
- Lift the front casing and remove it from the upper pins (e).

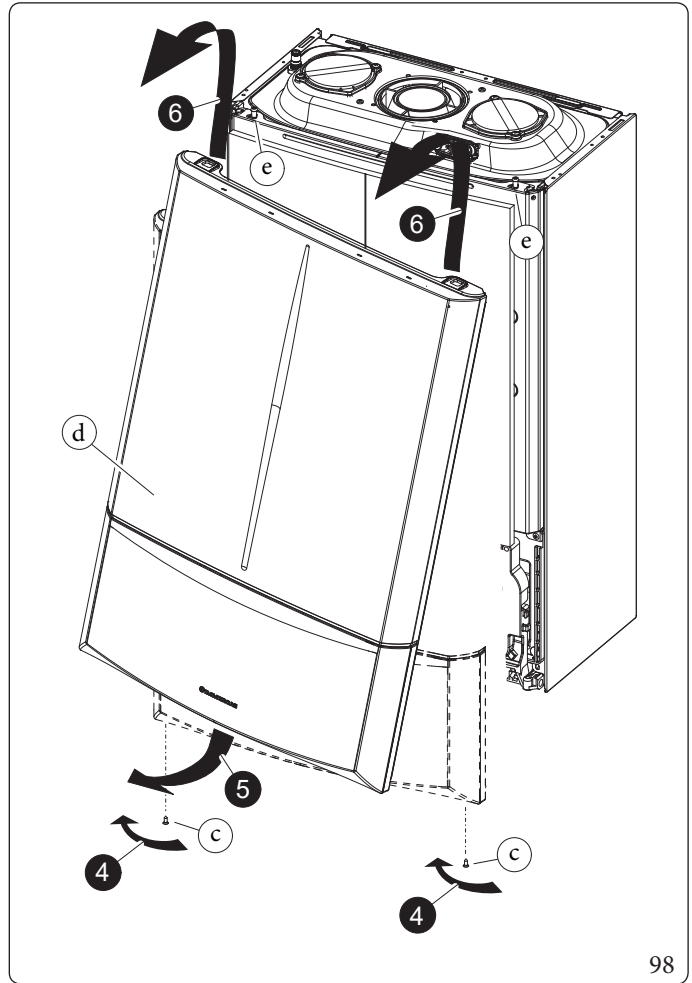
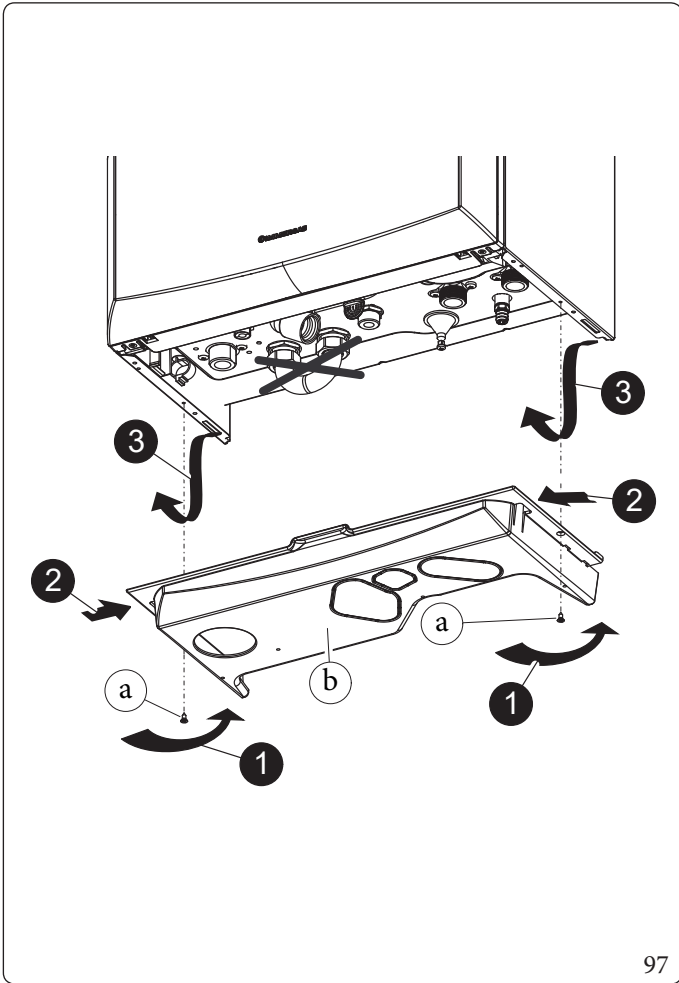

Reassembling the front casing.

Follow the instructions below to reinstall the front casing:

- Insert the front into the upper pins (e).
- Bring it to the end stop against the control panel with the door closed.
- Open the door and press around the user interface area, ensuring that it engages with the control panel.
- Close the door and tighten the screws (c).

Sealed chamber cover (Fig. 99)

- Unscrew the two screws (g) at the bottom of the sealed chamber cover (f).
- Pull the sealed chamber cover (f) slightly towards yourself.
- Release the sealed chamber cover (f) from the pins (h) by pulling it towards yourself while pushing it upwards.

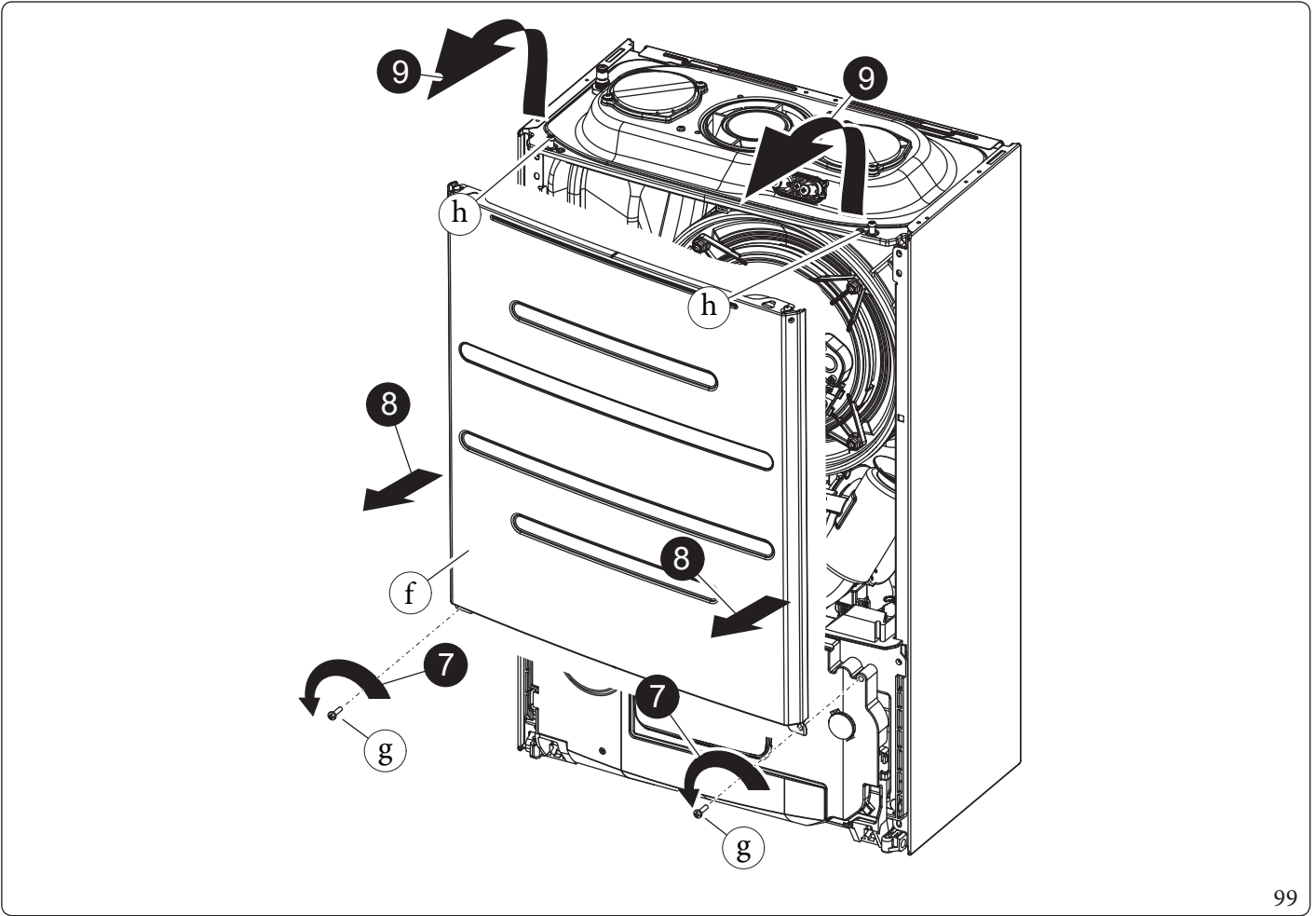

Control panel (Fig. 100)

- Press the hooks on the side of the control panel (i).
- Tilt the control panel (i) towards you.

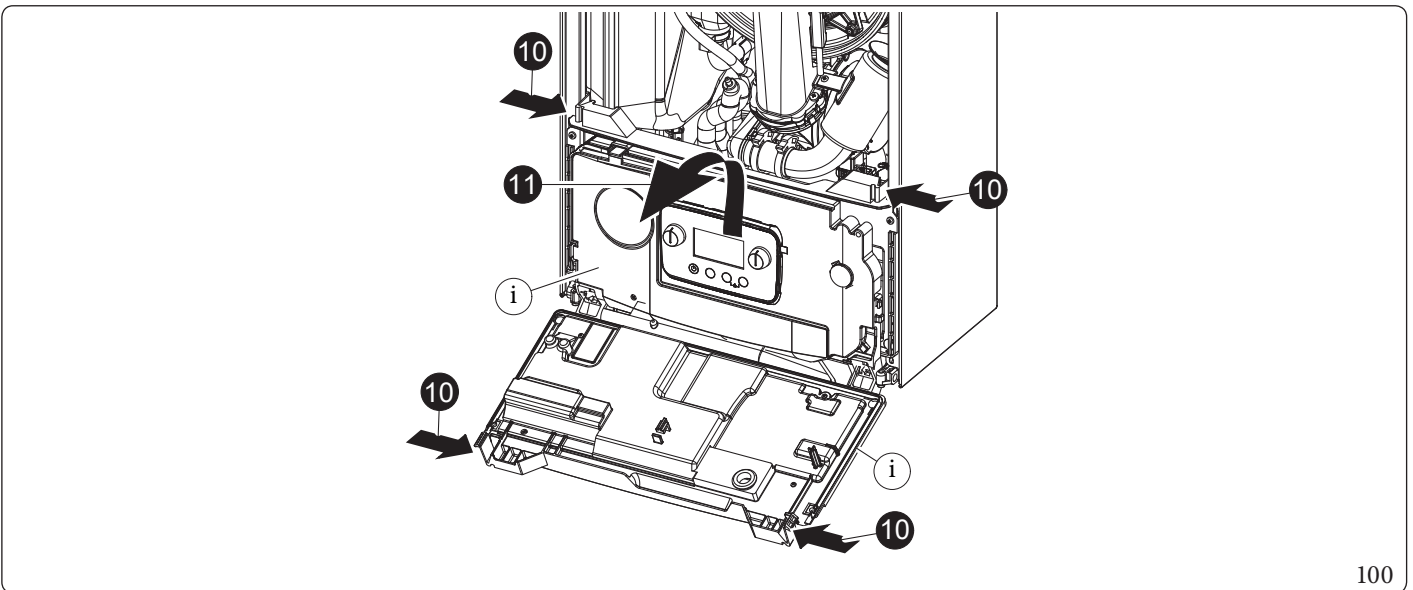

Sides (Fig. 101)

- Loosen screws (k) of side fastening (j).
- Remove the sides by extracting them from their rear seat (Ref. X).

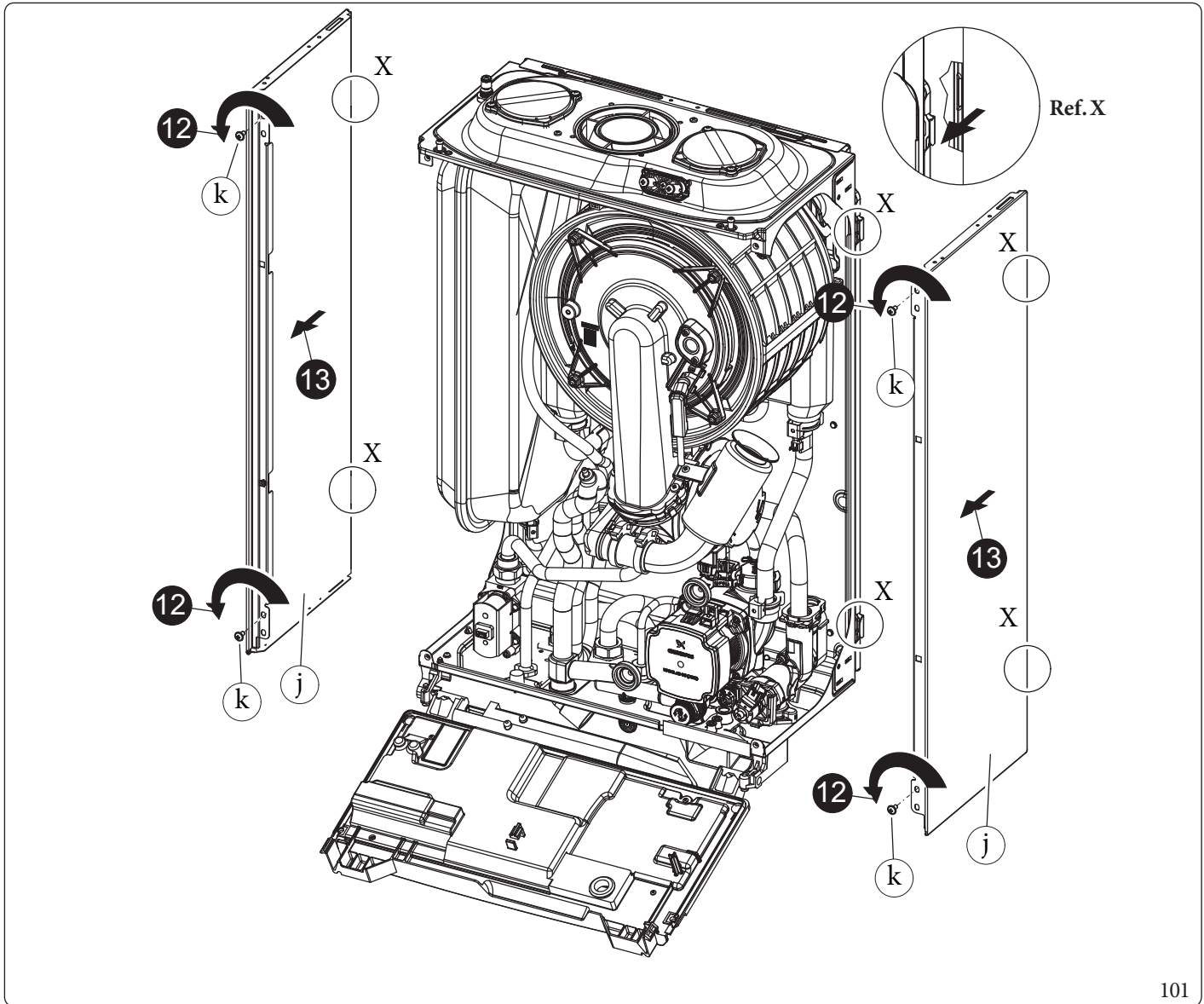

INSTALLER

USER

MAINTENANCE TECHNICIAN

TECHNICAL DATA

3.24 REPLACING THE MANIFOLD INSULATING PANEL



The operations described below must be performed after having removed the voltage from the appliance.

1. To access the inside of the appliance, remove the casing as indicated in Paragr. 3.23.
2. Unscrew the 4 manifold fastening nuts (1, Fig. 105) and gently pull them out towards you at right angles.
3. Unscrew the fixing screws (6) of the ignition and detection electrode (5) and remove it.
4. Remove the insulating panel (1) by actuating a blade (2) under its surface.
5. Remove the residue of the fixing adhesive from the surface of the manifold (3).
6. Replace the insulating panel (1).



The new insulating panel, used as a spare to replace the removed one, does not need to be fixed with glue as its shape with the interference on the burner ensures correct coupling with the manifold.

7. Refit the ignition and detection electrode (5) using the previously removed screws (6) and replace the relative gasket (4).

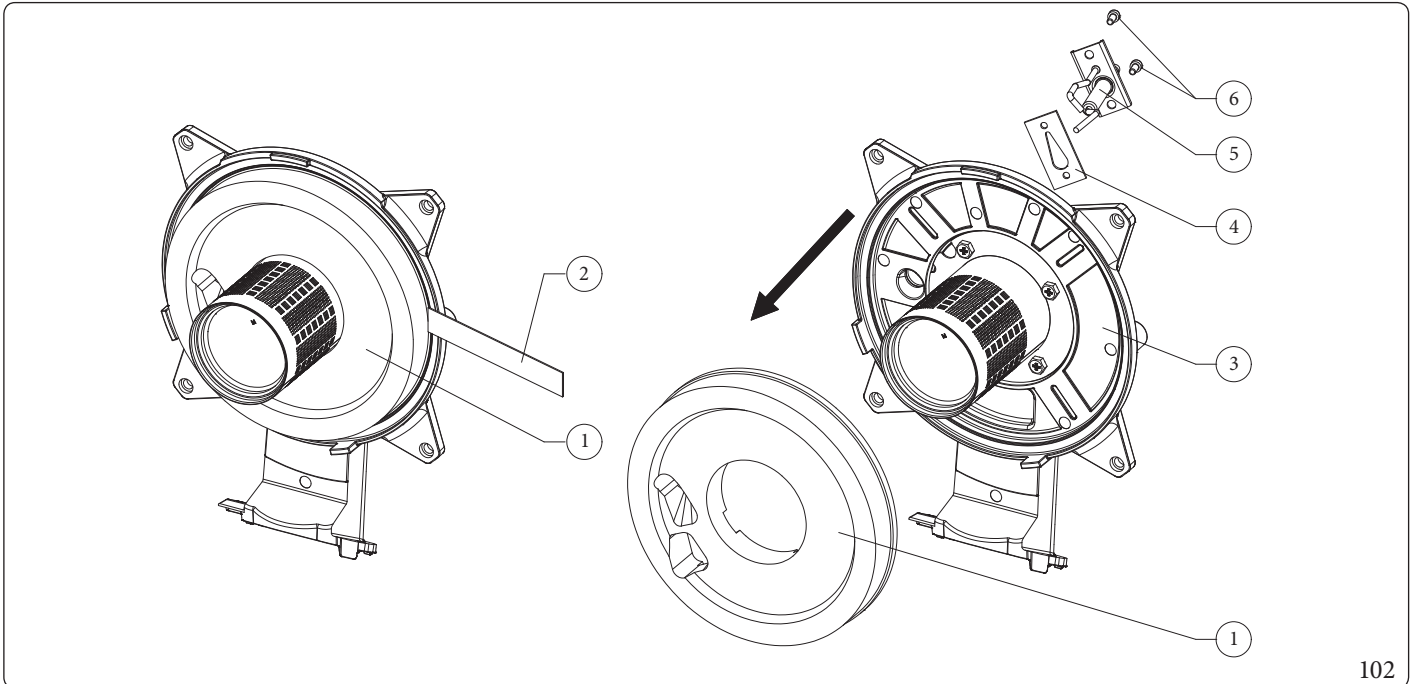

Electrode distance

To regain optimal operation, make sure that the following variables are respected when refitting the electrodes.

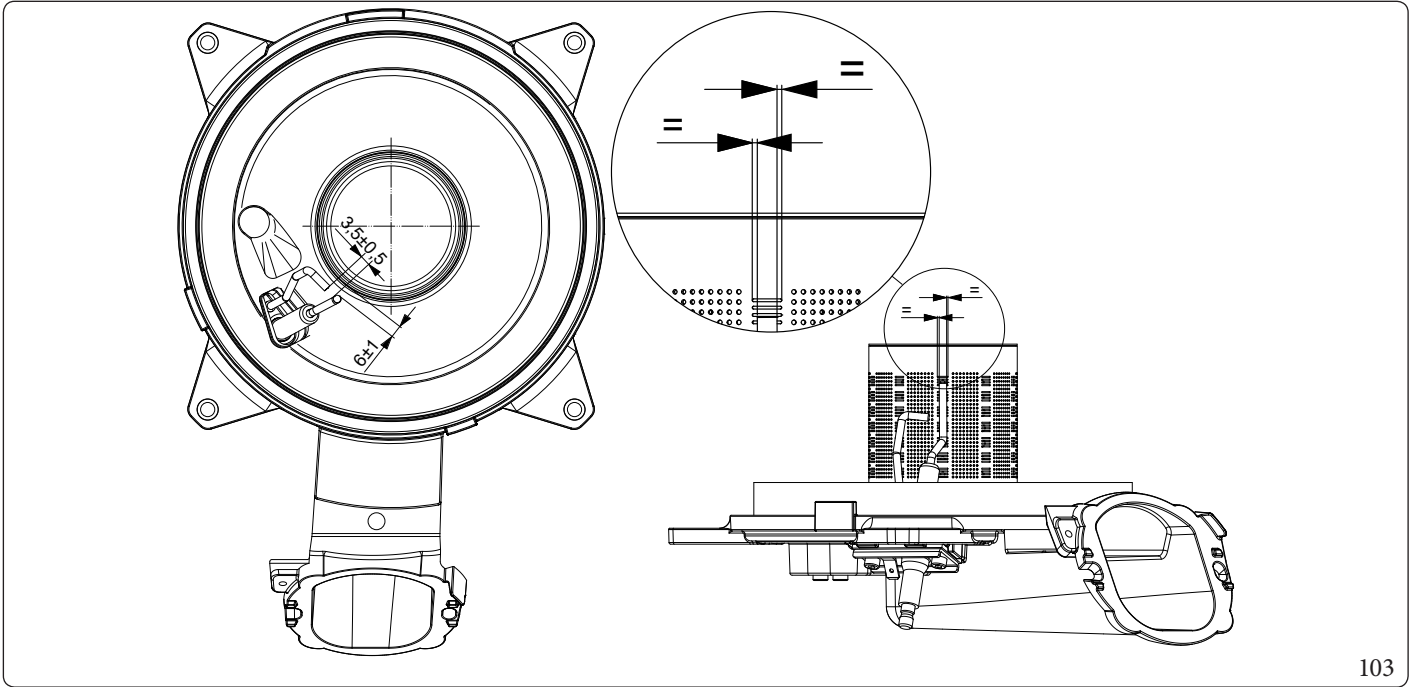

103

INSTALLER

USER

MAINTENANCE/TECHNICIAN

TECHNICAL DATA

3.25 ASSEMBLY OF MANIFOLD GASKET ON CONDENSATION MODULE



The operations described below must be performed after having removed the voltage from the appliance.

If the gasket has to be replaced, proceed as follows:

1. Remove the old gasket.
2. Place the module gasket (1) radially on the edge of the condensation module flange (2).
3. Make sure that the gasket tab with number 4 printed on it is positioned in its seat on the module flange, identified by the number 4.



Every time the manifold is opened, the condition and integrity of the ceramic fibres must be verified and replaced, if necessary. The manifold gasket, on the other hand, must be replaced every 2 years. After replacing the external silicone gasket, it is mandatory to check the fume tightness.

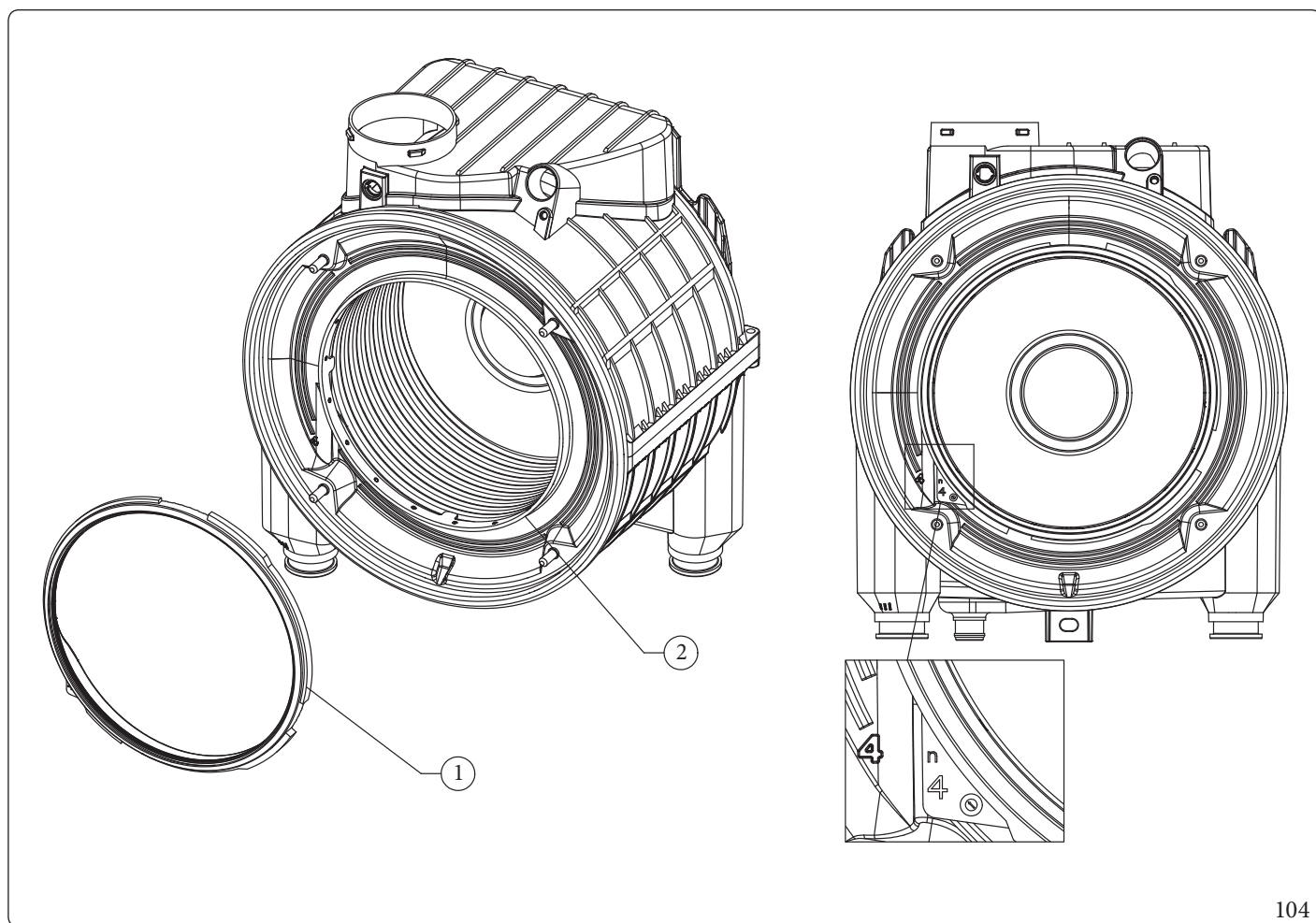

3.26 ASSEMBLING THE MANIFOLD ON THE CONDENSATION MODULE

1. Set the manifold on the module.
2. Tighten the 4 nuts (1) on the condensation module (3) according to the sequence (A, B, C, D) indicated in the drawing.

i The tightening torque when assembling the manifold (2) on the condensation module (3) must be 4 Nm.
Do not exceed 5 Nm.

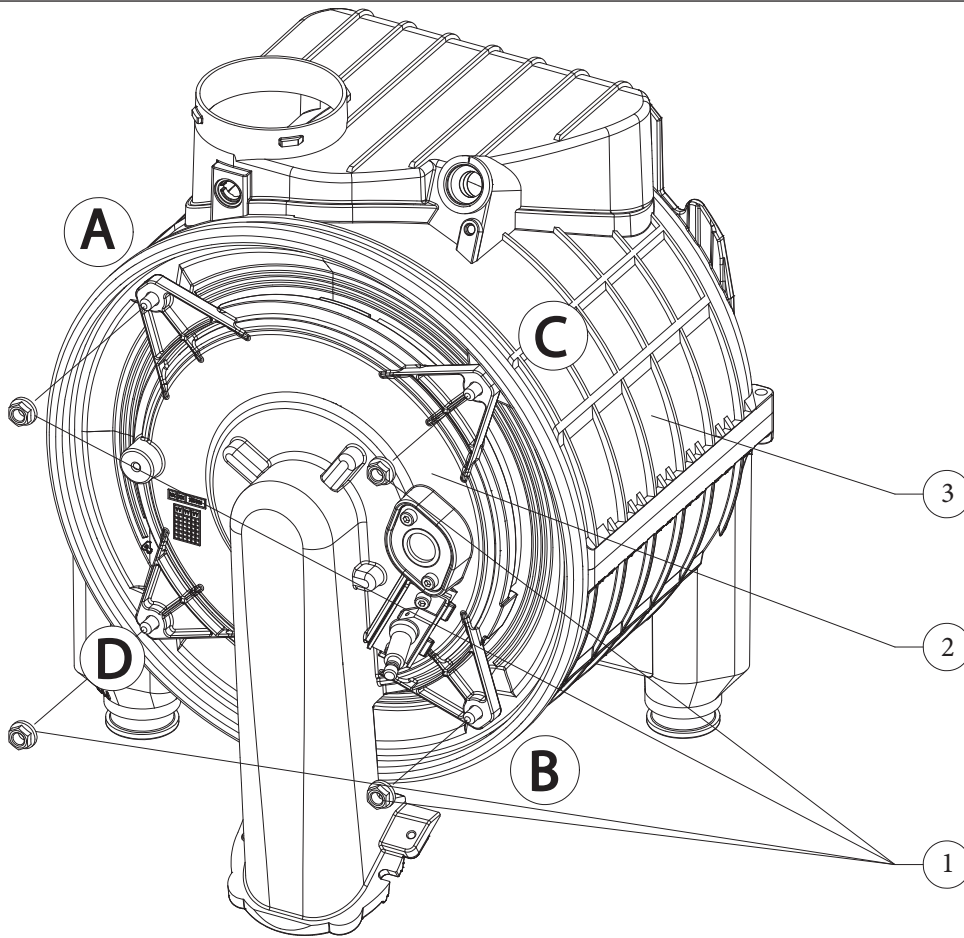

105

INSTALLER

USER

MAINTENANCE TECHNICIAN

TECHNICAL DATA

3.27 SPECIFIC INFORMATION FOR CORRECT APPLIANCE INSTALLATION IN COMMON PRESSURISED FLUE SYSTEMS (C₍₁₀₎ - C₍₁₂₎)



The appliance is factory equipped with a flue gas non-return valve located downstream of the fan, this device, given the importance of its correct operation, must have its installations C₍₁₀₎ and C₍₁₂₎ checked on an annual basis, and the active rubber element must be replaced in case of cuts in the moving parts.



For safety reasons, the flue gas non-return valve (inside the appliance) must be replaced after 10 years of operation.

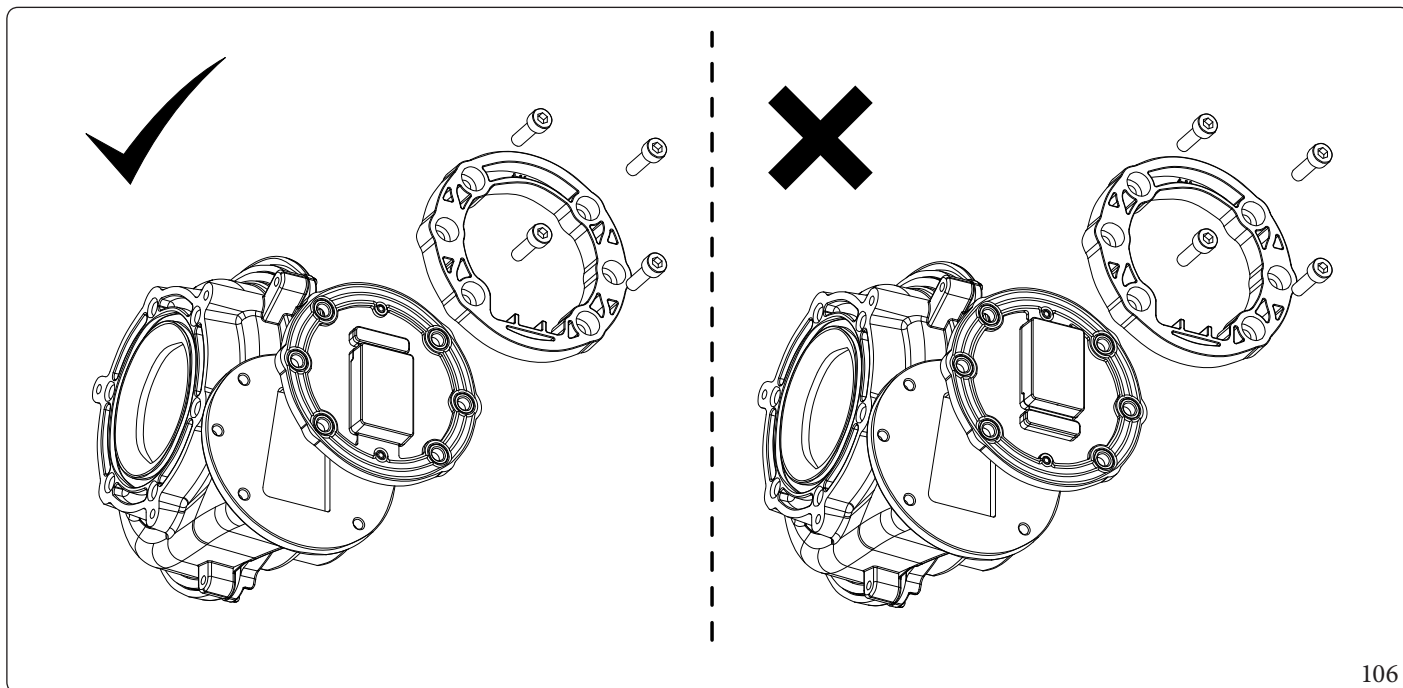

Before removing the sealing elements of the sealed chamber, using the flue gas analyser and with the appliance off, check that there are no traces of combustion products in the flue gas sample point.

The presence of combustion products indicates that the non-return valve on the flue gas (in appliance exhaust) is not properly closed, in which case it is appropriate to check the absence of flue gas even in the sealed chamber (analysis via air sample point).



If malfunctions are detected on the flue gas non-return valves, especially on the discharge valve, in the absence of a shut-off flue adjusting device at the coupling point of the flue in the pressurised collective flue, it will be necessary to turn off all the boilers connected to the pressurised collective flue itself, or make sure to intercept the connection point to avoid the dispersion of combustion products into the environment.

Only then proceed to verify the components, making sure that the non-return valve siphon on the flue gas (on the exhaust) (Fig. 45) is full and replacing them if malfunctioning or damaged.

4 TECHNICAL DATA

4.1 VARIABLE HEAT OUTPUT



The power data in the table has been obtained with intake-exhaust pipe measuring 0.5 m in length. Gas flow rates refer to net calorific value below a temperature of 15°C and at a pressure of 1013 mbar.

FLOWRATE OUTPUT	HEAT OUTPUT		METHANE (G20)			PROPANE (G31)		
			FANREVS		GASFLOW RATE BURNER	FANREVS		GASFLOW RATE BURNER
			(rpm)	(%)	(m³/h)	(rpm)	(%)	(kg/h)
34,0	33,0	D.H.W.	7200	100	3,60	6900	100	2,64
32,9	32,0	HEAT. + D.H.W.	6950	96	3,48	6600	94	2,56
31,0	30,2		6650	90	3,28	6325	88	2,41
29,0	28,2		6325	83	3,07	6050	82	2,25
27,5	26,8		6100	79	2,91	5825	77	2,14
25,5	24,9		5775	72	2,70	5550	71	1,98
23,5	23,0		5475	66	2,49	5250	65	1,83
21,5	21,0		5150	60	2,28	4975	59	1,67
19,5	19,1		4825	53	2,06	4675	52	1,51
17,9	17,5		4575	48	1,89	4450	47	1,39
16,0	15,6		4275	42	1,69	4175	41	1,24
14,0	13,6		3975	36	1,48	3900	35	1,09
12,0	11,6		3650	29	1,27	3625	29	0,93
10,5	10,2		3425	25	1,11	3400	24	0,82
8,5	8,2		3100	18	0,90	3125	18	0,66
6,5	6,2		2775	12	0,69	2825	12	0,50
4,5	4,3		2475	6	0,48	2550	6	0,35
2,8	2,7		2200	0	0,30	2300	0	0,22

INSTALLER

USER

MAINTENANCE TECHNICIAN

TECHNICAL DATA

4.2 COMBUSTION PARAMETERS

Combustion parameters: measuring conditions of useful efficiency (flow temperature/return temperature= 80/60 °C), ambient temperature reference = 20 °C.

Gastype		G20	G31
Supply pressure	mbar	20,0	37,0
Gas nozzle diameter	mm	5,70	5,70
Flue flow rate at D.H.W. nominal heat output	kg/h	57	58
Flue flow rate at heating nominal heat output	kg/h	55	55
Flue flow rate at min heat output	kg/h	5	5
CO ₂ at Nominal Q.	%	8,8 (8,3 ÷ 9,3)	10,0 (9,5 ÷ 10,5)
O ₂ at Nominal Q.	%	5,1 (6,0 ÷ 4,2)	- (- ÷ -)
CO ₂ at Minimum Q.	%	8,8 (8,3 ÷ 9,3)	9,5 (9,0 ÷ 10,0)
O ₂ at Minimum Q.	%	5,1 (6,0 ÷ 4,2)	- (- ÷ -)
CO with 0% O ₂ at Nom./Min. Q.	ppm	168 / 4	197 / 3
NO _x with 0% O ₂ at Nom./Min. Q.	mg/kWh	30 / 19	32 / 18
Flue temperature at nominal output	°C	79	79
Flue temperature at minimum output	°C	56	53

When using H2NG mixtures with H₂ percentages up to 20% (referring to the gas distributed in the network), all calibration operations of the device must refer to the O₂ values of the G20 gas given in the following table.

4.3 TECHNICAL DATA TABLE

		VICTRIX MAIOR 35 PLUS
Domestic hot water nominal heat input	kW	34,0
Central heating nominal heat input	kW	32,9
Minimum heat input	kW	2,8
DHW nominal heat input with 20% H ₂ NG gas	kW	30,8
Po Central heating nominal heat input with 20% H ₂ NG gas	kW	30,1
Minimum heat input with 20% H ₂ NG gas	kW	2,8
Domestic hot water nominal heat output (useful)	kW	33,0
Central heating nominal heat output (useful)	kW	32,0
Minimum heat output (useful)	kW	2,7
*Effective thermal efficiency 80/60 Nom./Min.	%	97,2 / 95,5
*Effective thermal efficiency 50/30 Nom./Min.	%	105,6 / 107,9
*Effective thermal efficiency 40/30 Nom./Min.	%	107,3 / 109,2
Efficiency at 100% heat output (η_{100}) ref. UNIEN 15502-1	%	98,0
Efficiency at partial heat load (η_{30}) ref. UNIEN 15502-1	%	109,5
Casing losses with burner On/Off	%	0,27 / 0,10
Chimney losses with burner Off/On	%	0,01 / 2,70
Maximum heating temperature	°C	90
Adjustable central heating temperature (min. operating field)	°C	20
Adjustable central heating temperature (max operating field)	°C	85
System expansion vessel total volume	l	6,0
Expansion vessel pre-charged pressure	bar	1,0
Appliance water content	l	3,4
Head available with 1000l/h flow rate	kPa	26,7
Domestic hot water adjustable temperature	°C	0 / 0
Central heating circuit max. operating pressure	bar	3,0
Domestic hot water circuit min. pressure (dynamic)	bar	-
Domestic hot water circuit max. operating pressure	bar	10,0
Flow rate capacity in continuous duty (ΔT 30°C)	l/min	-
Weight of full boiler	kg	36,2
Weight of empty boiler	kg	32,8
Electrical connection	V/Hz	230 / 50
Nominal power absorption	A	1,1
Installed electric power	W	140
Equipment electrical system protection	IP	X5D
Ambient operating temperature range	°C	-5 ÷ 40
Ambient operating temperature range with antifreeze kit (optional)	°C	-15 ÷ 40
NO _x class	-	6
*Weighted NO _x G20	mg/kWh	28
Weighted CO G20	mg/kWh	24
Weighted NO _x G31	mg/kWh	26
Weighted CO G31	mg/kWh	27
Type of appliance	-	B ₂₃ B _{23p} B ₃₃ B ₅₃ B _{53p} C ₁₃ C ₃₃ C ₄₃ C ₅₃ C ₆₃ C ₈₃ C ₉₃ C _{13X} C _{33X} C _{43X} C _{53X} C _{63X} C _{83X} C _{93X} C ₍₁₀₎₃ C ₍₁₂₎₃ C ₍₁₅₎₃
Market	IE	IL
Category	II2H3P	II2H3P Extra UE

* Efficiencies and weighted NO_x refer to the net calorific value.

The data relevant to domestic hot water performance refer to a dynamic inlet pressure of 2 bar and an inlet temperature of 15°C; the values are measured directly at the appliance outlet considering that to obtain the data declared mixing with cold water is necessary. For type C63 it is forbidden to install the appliance as it came out of the factory, in configurations that require shared flues in positive pressure.

Configurations C₍₁₀₎ and C₍₁₂₎ are only permitted with original, approved flue system

The appliance is suitable for operation in a C₍₁₀₎ or C₍₁₂₎ system and only with the supply of methane gas (2H and 2E categories).

INSTALLER

USER

MAINTENANCE TECHNICIAN

TECHNICAL DATA

4.4 DATA NAMEPLATE AND INSTALLATION INFORMATION STICKER KEY

Md.		Cod.Md.	
Sr N°	CHK	PIN	T.
Type			
Qnw/Qn min	Qnw/Qn max	Pn min	Pn max
PMS	PMW	D	TM
NOx Class			CONDENSING

107



The technical data are provided on the data plate on the appliance.

	ENG
Md.	Model
Cod. Md.	Model code
Sr N°	Serial Number
CHK	Check
PIN	PIN code
T.	Minimum and maximum installation temperature
Type	Type of installation (ref. UNI EN 1749)
Qnw min	Minimum DHW heat input
Qn min	Central heating minimum heat input
Qnw max	DHW maximum heat input
Qn max	Central heating maximum heat input
Pn min	Minimum heat output
Pn max	Maximum heat output
PMS	Maximum system pressure
PMW	Maximum domestic hot water pressure
D	Specific flow rate
TM	Maximum operating temperature
NOx Class	NOx Class
CONDENSING	Condensing boiler

Installation information sticker

Md	
Sr N°	
Qr	kW
Qrw	kW
Typ-ins	

108

Key (Fig. 108):

- Md. - Appliance model
- Sr N. - Equipment serial number (see equipment data nameplate)
- Qr. - Heating output at which the appliance is set
- Qrw. - DHW power at which the appliance is set
- Typ-ins - Type of flue installation (see technical data table)



At the time of installation, the authorised technician must fill in the facsimile of the installation information sticker (Fig. 108) with the information indicated. This sticker is also found inside the warranty unit, must also be filled out and attached to the outside of the unit (visible) (see paragraph 3.2 Initial check).

4.5 TECHNICAL PARAMETERS FOR COMBINATION BOILERS (IN COMPLIANCE WITH REGULATION 813/2013)

The efficiencies and NO_x values in the following tables refer to the gross calorific value.

Model	VICTRIX MAIOR 35 PLUS		
Condensing Boiler	YES		
Low temperature boiler	NO		
Boiler type B1	NO		
Co-generation appliance for central heating	NO		
Mixed heating appliance	NO		
Nominal heat output	P _n	32	kW
Seasonal energy efficiency of central heating	η _s	94	%
For central heating only and combination boilers: useful heat output			
At nominal heat output in high temperature mode (*)	P ₄	32,0	kW
At 30% of nominal heat output in a low temperature mode (**)	P ₁	10,8	kW
For central heating only and combination boilers: useful efficiency			
At nominal heat output in high temperature mode (*)	η ₄	88,2	%
At 30% of nominal heat output in a low temperature mode (**)	η ₁	98,6	%
Auxiliary electricity consumption			
At full load	e _{l,max}	0,023	kW
At partial load	e _{l,min}	0,014	kW
In standby mode	P _{SB}	0,002	kW
Other items			
Heat loss in standby	P _{stby}	0,054	kW
Ignition burner energy consumption	P _{ign}	0,000	kW
Emissions of nitrogen oxides	NO _x	25	mg/kWh
(*) High temperature mode means 60°C on return and 80°C on flow.			
(**) Low temperature mode for condensation Boilers means 30°C, for low temperature boilers 37°C and for other appliances 50°C of return temperature.			

INSTALLER

USER

MAINTENANCE TECHNICIAN

TECHNICAL DATA

4.6 PRODUCT FICHE (IN COMPLIANCE WITH REGULATION 811/2013)

INSTALLER

USER

MAINTENANCE TECHNICIAN

TECHNICAL DATA

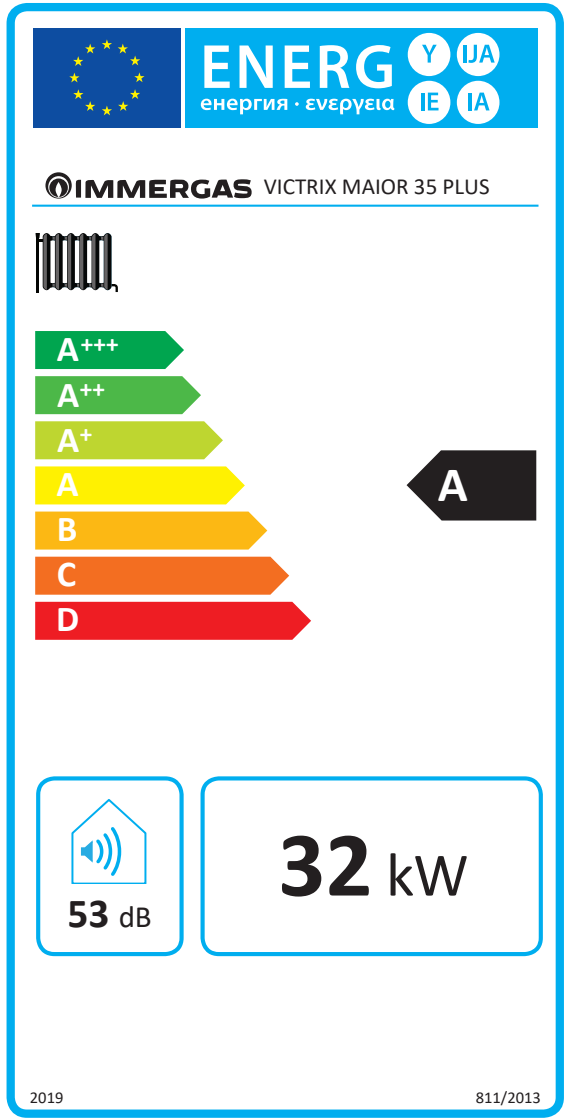

109

Parameter	Value	
Annual energy consumption for the central heating mode (QHE)	54	Gj
Seasonal space heating energy efficiency (ηs)	94	%

4.7 PARAMETERS FOR FILLING IN THE PACKAGE FICHE

If an assembly is to be made from this device, use the assembly sheets shown in (Fig. 111 and 113).

For the correct compilation, insert into the appropriate spaces (as shown in the facsimile package fiche (Fig. 110 and 112) the values set out in the tables "Parameters for compiling package fiche" and "Parameters for compiling DHW pack package fiche".

The remaining values must be obtained from the technical data sheets of the products used to make up the assembly (e.g. solar devices, integration heat pumps, temperature controllers).

Use sheet (Fig. 111) for "assemblies" related to the heating function (e.g.: boiler + temperature controller).

Use sheet (Fig. 113) for "assemblies" related to the domestic hot water function (e.g.: boiler + solar thermal system).

Facsimile for filling in the package fiche for room central heating systems.

Seasonal central heating energy efficiency of the boiler	<input type="text" value="I"/>	%
Temperature control From temperature control board	Class I = 1 %, Class II = 2 %, Class III = 1.5 %, Class IV = 2 %, Class V = 3 %, Class VI = 4 %, Class VII = 3.5 %, Class VIII = 5 %	+ <input type="text"/>
Supplementary boiler From boiler board	Seasonal central heating energy efficiency of the room (%) (<input type="text"/> - 'I') x 0.1 = ± <input type="text"/>	%
Solar contribution From the board of the solar device	Dimensions of the manifold (in m ²) Volume of the tank (in m ³) Efficiency of the manifold (in %) Classification of the tank A* = 0.95, A = 0.91, B = 0.86, C = 0.83, D-G = 0.81	+ <input type="text"/>
Supplementary heat pump From the heat pump board	Seasonal central heating energy efficiency of the room (%) (<input type="text"/> - 'I') x 'II' = + <input type="text"/>	%
Solar contribution and supplementary heat pump Select the lowest value	0.5 x <input type="text"/> O 0.5 x <input type="text"/>	= - <input type="text"/>
Seasonal central heating energy efficiency of the set	<input type="text"/>	%
Seasonal central heating energy efficiency class of the set	<input type="checkbox"/> <input type="checkbox"/> <input type="checkbox"/> <input type="checkbox"/> <input type="checkbox"/> <input type="checkbox"/> <input type="checkbox"/> <input type="checkbox"/> <input type="checkbox"/> <input type="checkbox"/> <input type="checkbox"/> G F E D C B A A⁺ A⁺⁺ A⁺⁺⁺ < 30 % ≥ 30 % ≥ 34 % ≥ 36 % ≥ 75 % ≥ 82 % ≥ 90 % ≥ 98 % ≥ 125 % ≥ 150 %	
Boiler and supplementary heat pump installed with low temperature heat emitters at 35 °C? From the board of the heat pump	<input type="text"/>	+ (50 x 'II') = <input type="text"/>

The energy efficiency of the set of products indicated in this sheet may not reflect the actual energy efficiency after installation since such efficiency is affected by additional factors, such as the heat loss in the distribution system and the size of the products compared to the size and features of the building.

INSTALLER

USER

MAINTENANCE TECHNICIAN

TECHNICAL DATA

Parameters for filling in the assembly chart

Parameter	VICTRIXMAIOR 35 PLUS
"I"	94
"II"	*
"III"	0,84
"IV"	0,33

* to be established by means of table 5 of Regulation 811/2013 in case of "assembly" including a heat pump to integrate the boiler. In this case the boiler must be considered as the main appliance of the assembly.

Room central heating system package fiche.

Seasonal central heating energy efficiency of the boiler 1 %

Temperature control
From temperature control board 2 %

Class I = 1 %, Class II = 2 %,
 Class III = 1.5 %, Class IV = 2 %,
 Class V = 3 %, Class VI = 4 %,
 Class VII = 3.5 %, Class VIII = 5 %

Supplementary boiler
From boiler board 3 %

Seasonal central heating energy efficiency of the room (%)

$$(\text{ } - \text{ }) \times 0.1 = \pm \text{ } \%$$

Solar contribution
From the board of the solar device 4 %

Dimensions of the manifold (in m²)

Volume of the tank (in m³)

Efficiency of the manifold (in %)

Classification of the tank
A* = 0.95, A = 0.91,
B = 0.86, C = 0.83,
D-G = 0.81

$$(\text{ } \times \text{ } + \text{ } \times \text{ }) \times (0.9 \times (\text{ } / 100) \times \text{ }) = + \text{ } \%$$

Supplementary heat pump
From the heat pump board 5 %

Seasonal central heating energy efficiency (in %)

$$(\text{ } - \text{ }) \times \text{ } = + \text{ } \%$$

Solar contribution and supplementary heat pump

Select the lowest value 6 %

$$0.5 \times \text{ } \text{ O } 0.5 \times \text{ } = - \text{ } \%$$

Seasonal central heating energy efficiency of the set 7 %

Seasonal central heating energy efficiency class of the set

<input type="checkbox"/>	<input type="checkbox"/>	<input type="checkbox"/>	<input type="checkbox"/>	<input type="checkbox"/>	<input type="checkbox"/>	<input type="checkbox"/>	<input type="checkbox"/>	<input type="checkbox"/>	<input type="checkbox"/>
G	F	E	D	C	B	A	A⁺	A⁺⁺	A⁺⁺⁺
< 30 %	≥ 30 %	≥ 34 %	≥ 36 %	≥ 75 %	≥ 82 %	≥ 90 %	≥ 98 %	≥ 125 %	≥ 150 %

Boiler and supplementary heat pump installed with low temperature heat emitters at 35 °C?

From the board of the heat pump 7 %

$$\text{ } + (50 \times \text{ }) = \text{ } \%$$

The energy efficiency of the set of products indicated in this sheet may not reflect the actual energy efficiency after installation since such efficiency is affected by additional factors, such as the heat loss in the distribution system and the size of the products compared to the size and features of the building.



Facsimile for filling in the domestic hot water production system package fiche

Water heating energy efficiency of combination boiler

¹
 %

Stated load profile:

Solar contribution

From the board of the solar device

Auxiliary electricity

$$(1.1 \times \text{'1'} - 10\%) \times \text{'1'} - \text{'III'} - \text{'1'} = + \text{² \%}$$

Water heating energy efficiency of the assembly in average climate conditions

³
 %

Water heating energy efficiency class of the assembly in average climate conditions

	<input type="checkbox"/>	<input type="checkbox"/>	<input type="checkbox"/>	<input type="checkbox"/>	<input type="checkbox"/>	<input type="checkbox"/>	<input type="checkbox"/>	<input type="checkbox"/>	<input type="checkbox"/>	<input type="checkbox"/>
	G	F	E	D	C	B	A	A⁺	A⁺⁺	A⁺⁺⁺
<input type="checkbox"/> M	< 27 %	≥ 27 %	≥ 30 %	≥ 33 %	≥ 36 %	≥ 39 %	≥ 65 %	≥ 100 %	≥ 130 %	≥ 163 %
<input type="checkbox"/> L	< 27 %	≥ 27 %	≥ 30 %	≥ 34 %	≥ 37 %	≥ 50 %	≥ 75 %	≥ 115 %	≥ 150 %	≥ 188 %
<input type="checkbox"/> XL	< 27 %	≥ 27 %	≥ 30 %	≥ 35 %	≥ 38 %	≥ 55 %	≥ 80 %	≥ 123 %	≥ 160 %	≥ 200 %
<input type="checkbox"/> XXL	< 28 %	≥ 28 %	≥ 32 %	≥ 36 %	≥ 40 %	≥ 60 %	≥ 85 %	≥ 131 %	≥ 170 %	≥ 213 %

Water heating energy efficiency class in colder and hotter climate conditions

Colder: ³ - 0.2 x ² = %

Hotter: ³ + 0.4 x ² = %

The energy efficiency of the set of products indicated in this sheet may not reflect the actual energy efficiency after installation since such efficiency is affected by additional factors, such as the heat loss in the distribution system and the size of the products compared to the size and features of the building.

Parameters for filling in the DHW package fiche

Parameter	VICTRIXMAIOR 35 PLUS
"I"	-
"II"	*
"III"	*

* to be determined according to Regulation 811/2013 and transient calculation methods as per Notice of the European Community no. 207/2014.

Domestic hot water production system package fiche.

Water heating energy efficiency of combination boiler

① %

Stated load profile:

Solar contribution

From the board of the solar device

Auxiliary electricity

$$(1.1 \times \text{---} - 10\%) \times \text{---} - \text{---} =$$

② %

Water heating energy efficiency of the assembly in average climate conditions

③ %

Water heating energy efficiency class of the assembly in average climate conditions

<input type="checkbox"/>	<input type="checkbox"/>	<input type="checkbox"/>	<input type="checkbox"/>	<input type="checkbox"/>	<input type="checkbox"/>	<input type="checkbox"/>	<input type="checkbox"/>	<input type="checkbox"/>	<input type="checkbox"/>
G	F	E	D	C	B	A	A⁺	A⁺⁺	A⁺⁺⁺
<input type="checkbox"/> M	$< 27\% \geq 27\% \geq 30\% \geq 33\% \geq 36\% \geq 39\% \geq 65\% \geq 100\% \geq 130\% \geq 163\%$								
<input type="checkbox"/> L	$< 27\% \geq 27\% \geq 30\% \geq 34\% \geq 37\% \geq 50\% \geq 75\% \geq 115\% \geq 150\% \geq 188\%$								
<input type="checkbox"/> XL	$< 27\% \geq 27\% \geq 30\% \geq 35\% \geq 38\% \geq 55\% \geq 80\% \geq 123\% \geq 160\% \geq 200\%$								
<input type="checkbox"/> XXL	$< 28\% \geq 28\% \geq 32\% \geq 36\% \geq 40\% \geq 60\% \geq 85\% \geq 131\% \geq 170\% \geq 213\%$								

Water heating energy efficiency class in colder and hotter climate conditions

Colder: $\text{---}^{\textcircled{3}} - 0.2 \times \text{---}^{\textcircled{2}} = \text{---} \%$

Hotter: $\text{---}^{\textcircled{3}} + 0.4 \times \text{---}^{\textcircled{2}} = \text{---} \%$

The energy efficiency of the set of products indicated in this sheet may not reflect the actual energy efficiency after installation since such efficiency is affected by additional factors, such as the heat loss in the distribution system and the size of the products compared to the size and features of the building.





This instruction booklet is made of ecological paper.

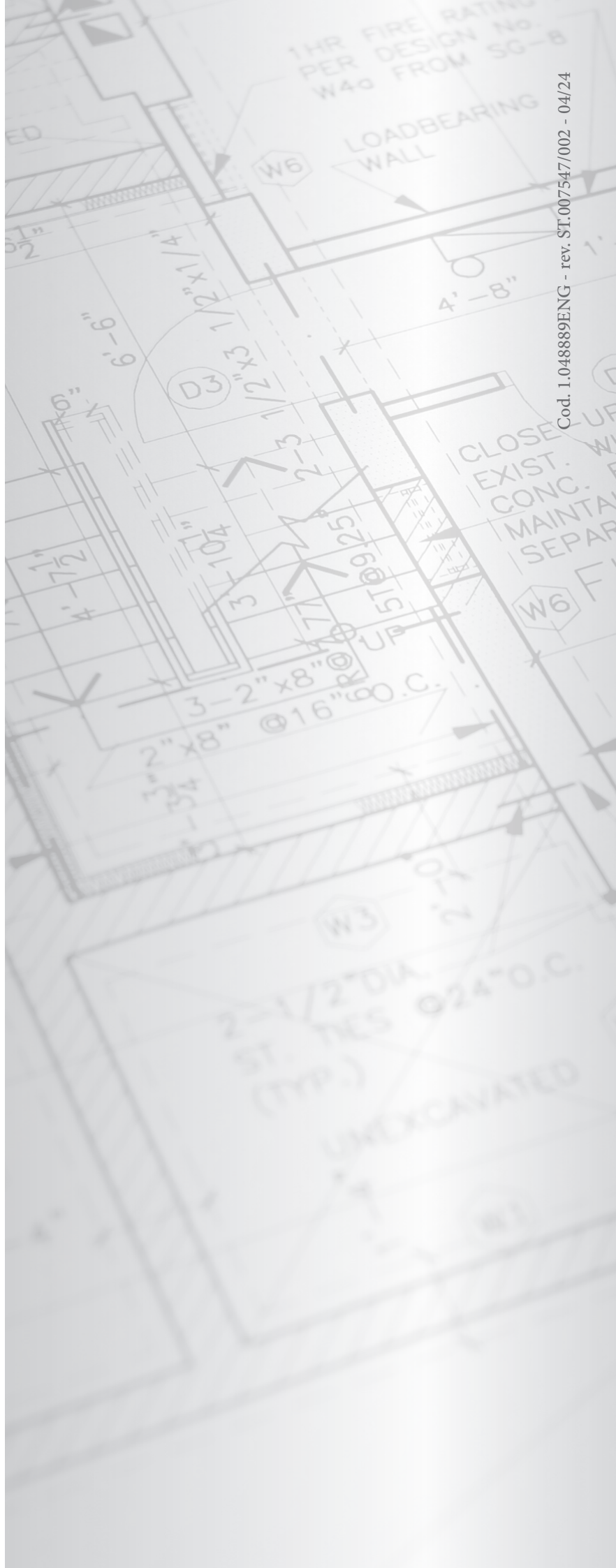

Cod. 1.048889ENG - rev. ST.007547/002 - 04/24

immergas.com

Immergas S.p.A.
42041 Brescello (RE) - Italy
Tel. 0522.689011
Fax 0522.680617



IMMERGAS
IMMERGAS SPA - ITALY
CERTIFIED COMPANY
UNI EN ISO 9001:2015

Design, manufacture and post-sale assistance of gas boilers, gas water heaters and related accessories