

VICTRIX PRO V2180 EU

AL IE IL

MK MT

Instructions and recom- mendations

Installer

User

Maintenance technician

Technical Data

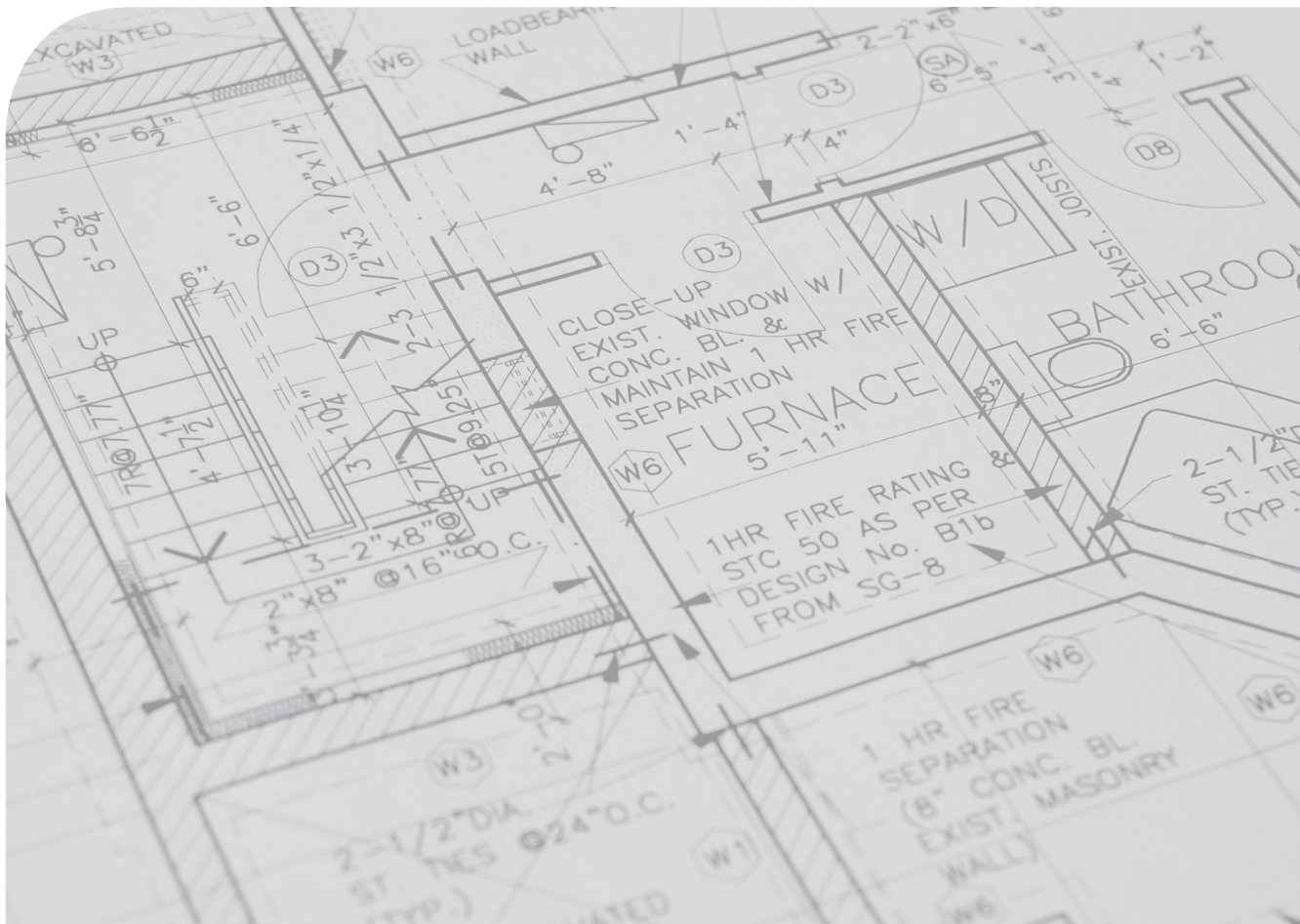

INDEX

Dear Customer.....	5
General Recommendations.....	6
Safety symbols used.....	7
Personal protective equipment	7
1 Unit installation	8
1.1 Installation warnings	8
1.2 Handling the appliance	12
1.3 Data nameplate and installation information sticker	12
1.4 Main dimensions	14
1.5 Minimum installation distances.....	15
1.6 Position of the appliances	16
1.7 Aeration and Ventilation of the installation rooms	17
1.8 Antifreeze protection	18
1.9 Other Antifreeze functions (Optionals).....	19
1.10 Gas connection.....	20
1.11 Hydraulic connection.....	21
1.12 Electrical connection.....	23
1.13 Commands for heat adjustment (Optional)	25
1.14 Hydraulic settings.....	30
1.15 Notes and tables in common of wiring diagrams.....	31
1.16 Hydraulic diagram - one direct zone - one mixed zone - 3-way valve - hydraulic manifold (one appliance)	32
1.17 Wiring diagram - one direct zone - one mixed zone - 3-way valve - hydraulic manifold (one appliance)	33
1.18 Wiring diagram - zone 2 mixed heating - 3-way valve - hydraulic manifold (one appliance).....	34
1.19 Wiring diagram - zone 2 mixed heating - 3-way valve - without hydraulic manifold (one appliance).....	35
1.20 Wiring diagram - two direct heating zones - 3-way valve - hydraulic manifold (one appliance)	36
1.21 Wiring diagram - zone 1 direct heating - 3-way valve - hydraulic manifold (one appliance).....	37
1.22 Wiring diagram - direct heating zone (without hydraulic manifold) - 3-way valve - domestic hot water thermostat (one appliance).....	38
1.23 Wiring diagram - two hydraulic zones with system heating pump - 3-way valve - hydraulic manifold (one appliance).....	39
1.24 Wiring diagram - two direct heating zones - 3-way valve (without hydraulic manifold) (one appliance)	40
1.25 Wiring diagram - direct heating zone with booster pump - 3-way valve with spring return - external probe present (OFF) (one appliance).....	41
1.26 Hydraulic diagram - one direct zone - one mixed zone - DHW pump.....	42
1.27 Wiring diagram - one direct zone - one mixed zone - DHW pump - hydraulic manifold (one appliance).....	43
1.28 Wiring diagram - zone 1 mixed - DHW pump - hydraulic manifold (one appliance).....	44
1.29 Wiring diagram - two direct heating zones - DHW pump - OpenTherm thermostats - hydraulic manifold (one appliance).....	45
1.30 Wiring diagram - zone 1 direct - DHW pump - hydraulic manifold (one appliance)	46
1.31 Wiring diagram - zone 1 direct - DHW pump - parallel operation - hydraulic manifold (one appliance).....	47
1.32 Wiring diagram - two direct heating zones - DHW pump - CH Request type Constant Setpoint - hydraulic manifold (one appliance).....	48
1.33 Wiring diagram - two direct heating zones - DHW pump - CH Request type Only OTC - hydraulic manifold (one appliance).....	49
1.34 Wiring diagram - direct heating zone - booster pump - without hydraulic manifold (one appliance)	50
1.35 Wiring diagram with high power remote control.....	51
1.36 Wiring diagram connection to BMS system	52
1.37 Wiring diagram BUS-Cascade connection	53
1.38 General examples of types of installation of flue systems	54
1.39 Immergas flue systems.....	55
1.40 Equivalent lengths of "Green Range" flue system components.....	56
1.41 Maximum flue length	57
1.42 Outdoor installation	58
1.43 Intake stub pipe kit installation for type B configurations.....	60
1.44 Installation of vertical terminals Ø 160.....	61
1.45 Installation of 160 Ø horizontal terminals	62
1.46 Separator kit installation.....	64
1.47 Configuration for C ₆ flue installation.....	66



1.48	Water treatment plant filling.....	68
1.49	System filling	69
1.50	Filling the condensate drain trap.....	69
1.51	Operation with system flow sensor.....	69
1.52	Simple cascade.....	70
1.53	Autodetection.....	72
1.54	Restore settings and parameter synchronisation	73
1.55	Heating zones	74
1.56	Operation with DHW storage tank (optional).....	74
1.57	Venting.....	74
1.58	Anti-legionella.....	75
1.59	Continuous pump operation in heating mode.....	75
1.60	Gas system start-up	75
1.61	Appliance start-up (Ignition).....	76
1.62	Circulation pump.....	77
1.63	Kits available on request	78
1.64	Main components	79
1.65	Hydraulic diagram with optional.....	80
1.66	Installation examples of single appliances.....	81
2	Instructions for use and maintenance	82
2.1	General recommendations	82
2.2	Cleaning and maintenance	84
2.3	Aeration and Ventilation of the installation rooms	84
2.4	Control panel.....	85
2.5	Using the appliance.....	86
2.6	Weekly schedule.....	88
2.7	Eco	88
2.8	Holidays	89
2.9	User menu	90
2.10	Fault and anomaly signals	99
2.11	Appliance switch-off.....	104
2.12	Restore central heating system pressure	104
2.13	Draining the system.....	104
2.14	Antifreeze protection	105
2.15	Prolonged inactivity	105
2.16	Cleaning the case.....	105
2.17	Permanent shutdown.....	105
3	Instructions for maintenance and initial check.....	106
3.1	General recommendations	106
3.2	Initial check	107
3.3	Yearly appliance check and maintenance	108
3.4	Hydraulic diagram.....	110
3.5	Wiring diagram.....	111
3.6	Troubleshooting.....	113
3.7	Technical menu	114
3.8	P.C.B. programming.....	134
3.9	Converting the appliance to other types of gas.....	135
3.10	CO ₂ /O ₂ regulation.....	137
3.11	Chimney sweep	138
3.12	CH output adjustment	138
3.13	Output adjustment during DHW (only in combination with an optional external storage tank).....	138
3.14	Pump antilock, 3-way valve and mixing valve (Optionals).....	138
3.15	Antifreeze	139



3.16	Gasket assembly on manifold	139
3.17	Assembling the manifold on the condensation module.....	140
3.18	Replacing the manifold insulating panel	141
3.19	Casing removal.....	142
4	Technical data.....	145
4.1	Variable heat output	145
4.2	Combustion parameters	146
4.3	Technical data table.....	147
4.4	Technical parameters for combination boilers (in compliance with Regulation 813/2013).....	148
4.5	Product fiche (in compliance with Regulation 811/2013).....	149
4.6	Parameters for filling in the package fiche	150



Dear Customer

Congratulations for having chosen a top-quality Immergas product, able to assure well-being and safety for a long period of time. As an Immergas customer you can also count on a Qualified Authorised After-Sales Technical Assistance Centre, prepared and updated to guarantee the constant efficiency of your products. Read the following pages carefully: you will be able to draw useful tips on the proper use of the device, compliance with which will confirm your satisfaction with the Immergas product.

For assistance and routine maintenance, contact Authorised Technical Service Centres: they have original spare parts and are specifically trained directly by the manufacturer.

The company **IMMERGAS S.p.A.**, with registered office in via Cisa Ligure 95 42041 Brescello (RE), declares that the design, manufacturing and after-sales assistance processes comply with the requirements of standard **UNIEN ISO 9001:2015**.

For further details on the product CE marking, request a copy of the Declaration of Conformity from the manufacturer, specifying the appliance model and the language of the country.

The manufacturer declines all liability due to printing or transcription errors, reserving the right to make any modifications to its technical and commercial documents without forewarning.





GENERAL RECOMMENDATIONS

This book contains important information for the:

Installer (section 1);

User (section 2);

Maintenance Technician (section 3).

- The user must carefully read the instructions in the specific section (section 2).
- The user must limit operations on the appliance only to those explicitly allowed in the specific section.
- The appliance must be installed by qualified and professionally trained personnel.
- The instruction booklet is an integral and essential part of the product and must be given to the new user in the case of transfer or succession of ownership.
- It must be stored with care and consulted carefully, as all of the warnings provide important safety indications for installation, use and maintenance stages.
- In compliance with the legislation in force, the systems must be designed by qualified professionals, within the dimensional limits established by the Law. Installation and maintenance must be performed in compliance with the regulations in force, according to the manufacturer's instructions and by professionally qualified staff, meaning staff with specific technical skills in the plant sector, as provided for by Law.
- Improper installation or assembly of the Immergas device and/or components, accessories, kits and devices can cause unexpected problems for people, animals and objects. Read the instructions provided with the product carefully to ensure proper installation.
- This instructions manual provides technical information for installing Immergas products. As for the other issues related to the installation of products (e.g. safety at the workplace, environmental protection, accident prevention), it is necessary to comply with the provisions of the standards in force and the principles of good practice.
- All Immergas products are protected with suitable transport packaging.
- The material must be stored in a dry place protected from the weather.
- Damaged products must not be installed.
- Maintenance must be carried out by skilled technical staff. For example, the Authorised Service Centre that represents a guarantee of qualifications and professionalism.
- The appliance must only be destined for the use for which it has been expressly declared. Any other use will be considered improper and therefore potentially dangerous.
- If errors occur during installation, operation and maintenance, due to non-compliance with technical laws in force, standards or instructions contained in this booklet (or however supplied by the manufacturer), the manufacturer is excluded from any contractual and extra-contractual liability for any damages and the device warranty is invalidated.
- In the event of malfunctions, faults or incorrect operation, turn the appliance off and contact an authorised company (e.g. the Authorised Technical Assistance Centre, which has specifically trained staff and original spare parts). Do not attempt to modify or repair the appliance alone.



SAFETY SYMBOLS USED



GENERIC HAZARD

Strictly follow all of the indications next to the pictogram. Failure to follow the indications can generate hazard situations resulting in possible harm to the health of the operator and user in general, and/or property damage.



ELECTRICAL HAZARD

Strictly follow all of the indications next to the pictogram. The symbol indicates the appliance's electrical components or, in this manual, identifies actions that can cause an electrical hazard.



MOVING PARTS

The symbol indicates the appliance's moving components that can cause hazards.



DANGER OF HOT SURFACES

The symbol indicates the appliance's very hot components that can cause burns.



WARNINGS

Strictly follow all of the indications next to the pictogram. Failure to follow the indications can generate hazard situations resulting in possible minor injuries to the health of both the operator and the user in general, and/or slight material damage.



ATTENTION

Read and understand the instructions of the appliance before carrying out any operation, carefully following the instructions given. Failure to observe the instructions may result in malfunction of the unit.



INFORMATION

Indicates useful tips or additional information.



EARTH TERMINAL CONNECTION

The symbol identifies the appliance's earth terminal connection point.



DISPOSAL WARNING

The user must not dispose of the appliance at the end of its service life as municipal waste, but send it to appropriate collection centres.

PERSONAL PROTECTIVE EQUIPMENT



SAFETY GLOVES



EYE PROTECTION



SAFETY FOOTWEAR



1 UNIT INSTALLATION

1.1 INSTALLATION WARNINGS



Operators who install and service the appliance must wear the personal protective equipment required by applicable law.



Individual and cascade (2 or more) Victrix Pro V2 180 EU appliances can be installed outdoors or in a suitable facility (heating control unit)



Installation must be carried out according to regulation standards, current legislation and in compliance with local technical regulations and the required technical procedures.



The place of installation of the appliance and relative Immergas accessories must have suitable features (technical and structural), such as to allow for (always in safe, efficient and comfortable conditions):

- installation (according to the provisions of technical legislation and technical regulations);
- maintenance operations (including scheduled, periodic, routine and special maintenance);
- removal (to outdoors in the place for loading and transporting the appliances and components) as well as the eventual replacement of those with appliances and/or equivalent components.



The wall surface must be smooth, without any protrusions or recesses enabling access to the rear part. They are not designed to be installed on plinths or floors (Fig. 1).



By varying the type of installation the classification of the appliance and precisely:

- **Type B₂₃ or B₅₃** appliance if installed using the relevant terminals for air intake directly from the room in which the appliance has been installed.
- **Type C appliance** if installed using the split pipes or other types of ducts envisioned for the sealed chamber appliance for intake of air and expulsion of flue gas.



The equipment classification is shown in the illustrations of the various installation solutions on the following pages.



Only professionally enabled companies are authorised to install Immergas gas appliances.



OK

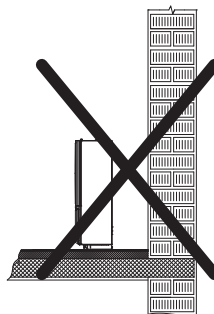



In the event of malfunctions, faults or incorrect operation, turn the appliance off and contact an authorised company (e.g. the Authorised Technical Assistance Centre, which has specifically trained staff and original spare parts). Do not attempt to modify or repair the appliance alone.



The manufacturer declines all liability in the event of damage caused by appliances removed from other systems or for any non-conformities with such equipment.



Check the environmental operating conditions of all parts relevant to installation, referring to the values shown in the technical data table in this booklet.



Installation of the appliance when powered by LPG must comply with the rules regarding gases with a greater density than air (remember, as an example, that it is prohibited to install plants powered with the above-mentioned gas in rooms where the floor is at a lower quota than the country level).



If installing a kit or servicing the appliance, always empty the system's circuit first so as not to compromise the appliance's electrical safety (Parag. 2.13). Always disconnect the appliance from voltage and, depending on the type of operation, decrease the pressure and/or bring it to zero in the system circuit.



It is just as important that the intake grids and exhaust terminals are not obstructed.



Check that no flue gas recirculation is found in the air sample points. Allow the appliance to reach the maximum heat output; the CO₂ value measured in the air must be less than 10% of that measured on the flue gas.



Keep all combustible material away from the appliance (paper, rags, plastic, polystyrene, etc.).



Split exhaust ducts must not pass through walls of combustible material.



Any modification to the appliance that is not explicitly indicated in this section of the booklet is forbidden.



Before installing the appliance, ensure that it is delivered in perfect condition; if in doubt, contact the supplier immediately. Packing materials (staples, nails, plastic bags, polystyrene foam, etc.) constitute a hazard and must be kept out of the reach of children. If the appliance is installed inside or between cabinets, ensure sufficient space for routine servicing; for minimum installation distances, see Fig. 8.

Installation standards



This type of installation is possible when permitted by the laws in force in the appliance's country of destination.





This unit can be installed outdoors in a partially protected location or in the open using the cover kit (optional). By partially protected area, we mean one in which the unit is not directly exposed to the elements (rain, snow, hail, etc.).



Installation of gas appliances, flue exhaust pipes and combustion air intake pipes is forbidden in places with a fire risk (for example: garages, closed parking stalls), and in potentially dangerous places.



Do not install in places/rooms that constitute public areas of apartment buildings, internal stairways or other escape routes (e.g. floor landings, entrance halls, etc.).



These appliances, if not adequately isolated, are not suitable for installation on walls of combustible material.



Wall mounting of the appliance must guarantee stable and efficient support for the generator.

The plugs (standard supply) that come with the appliance are only to be used to fix the latter to the wall; they only ensure adequate support if inserted correctly (according to technical standards) in walls made of solid or semi-hollow brick or block. In the case of walls made from hollow brick or block, partitions with limited static properties, or in any case walls other than those indicated, a static test must be carried out to ensure adequate mount. Appliances must be installed in such a way as to avoid knocks or tampering.



The hex head screws supplied in the blister pack are to be used exclusively to fix the relative mounting bracket to the wall.



These appliances are used to heat water to below boiling temperature in atmospheric pressure.



They must be attached to a heating system suitable for their capacity and voltage.

Risk of damage due to corrosion caused by unsuitable combustion air and environment.



Spray, solvents, chlorine-based detergents, paints, glue, ammonium compounds, powders and similar cause product and flue duct corrosion.



Check that combustion air power supply is free from chlorine, sulphur, powders, etc.



Make sure that no chemical substances are stored in the place of installation.



If you want to install the product in beauty salons, paint workshops, carpenter's shop, cleaning companies or similar, choose a separate installation area that ensures combustion air supply that is free from chemical substances.



Make sure the combustion air is not fed through chimneys that were previously used with boilers or other central heating appliances powered by liquid or solid fuels. In fact, these may cause an accumulation of soot in the chimney



Risk of material damage after using sprays and liquids to search for leaks



Leak sprays and liquids clog the reference hole PR Ref. (Fig. 70) of the gas valve, damaging it irreparably.
During installation and maintenance, do not use spray or liquids in the upper area of the gas valve (electric connections side).

Filling the condensate drain trap



When the appliance is switched on for the first time, combustion products come out of the condensate drain. After a few minutes of operation, check that combustion flue gases are no longer coming out of the condensate drain; this means that the drain trap has filled to a correct condensate height that the flue gases cannot pass through.

Special provisions for appliances installed in B₂₃ or B₅₃ configuration.



Open chamber appliances type B₂₃ and B₅₃ must not be installed in rooms in which commercial, craft or industrial activities are carried out where products are used that are capable of developing vapours or volatile substances (e.g. acid vapours, glues, paints, solvents, fuels, etc.), as well as dust (e.g. dust from wood processing, coal dust, cement dust, etc.) that could be harmful to the appliance's components and impair its operation.



In configuration B₂₃ and B₅₃, unless local regulations are in force, the appliances must not be installed in bedrooms, bathrooms, toilets or studios; they must neither be installed in rooms containing solid fuel heat generators nor in rooms communicating with said rooms.



Failure to comply with the above implies personal responsibility and invalidates the warranty.



1.2 HANDLING THE APPLIANCE



ATTENTION: the casing sides are not load-bearing, so in order to move the appliance, it is necessary to take it from the rear and front as shown in the figure 2 and not from the side.

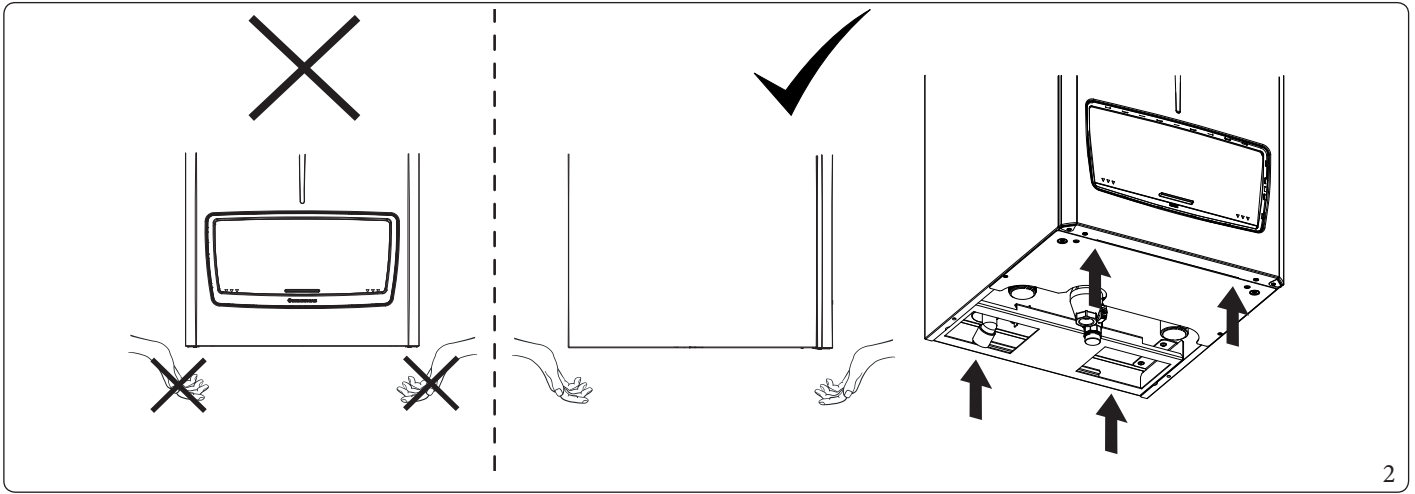

If the boiler needs to be moved with a lift, it is necessary to remove the siphon before carrying out this operation.

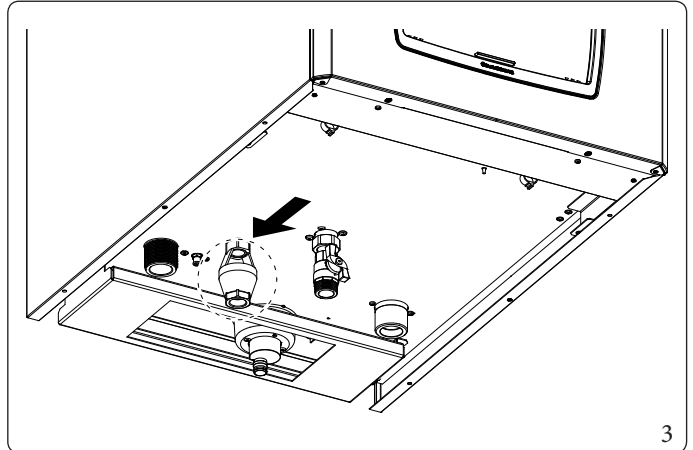

1.3 DATA NAMEPLATE AND INSTALLATION INFORMATION STICKER

Data nameplate positioning

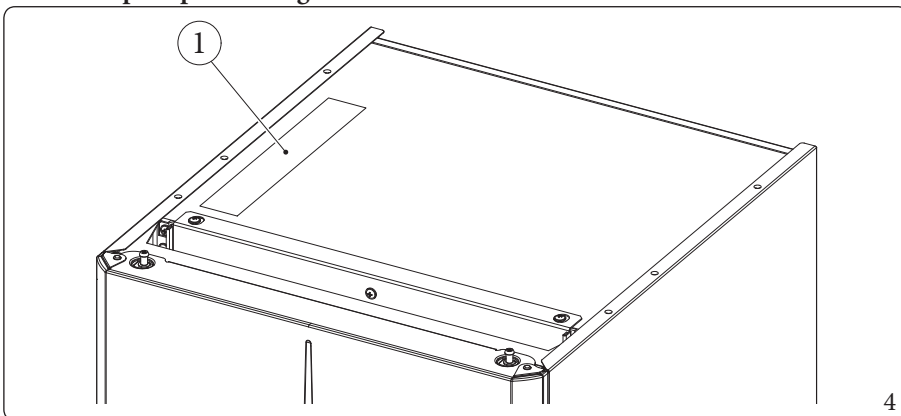

Key (Fig. 4):
1 - Dataplate



Key for data nameplate



The technical data are provided on the data plate on the appliance.

Md.		
Cod.Md.	PIN	
Sr N°	CHK	
Type		
Qnw/Qn min	Pn min	
Qnw/Qn max	Pn max	
PMS	TM	D
PMW	T.	
NOx Class		
CONDENSING		

5

	ENG
Md.	Model
Cod.Md.	Model code
Sr N°	Serial Number
CHK	Check
PIN	PIN code
T.	Minimum and maximum installation temperature
Type	Type of installation (ref. UNI EN 1749)
Qnw min	Minimum DHW heat input
Qn min	Central heating minimum heat input
Qnw max	DHW maximum heat input
Qn max	Central heating maximum heat input
Pn min	Minimum heat output
Pn max	Maximum heat output
PMS	Maximum system pressure
PMW	Maximum domestic hot water pressure
D	Specific flow rate
TM	Maximum operating temperature
NOx Class	NOx Class
CONDENSING	Condensing boiler

Installation information sticker

Md	
Sr N°	
Qr	kW
Qrw	kW
Typ-ins	

6

Key (Fig. 6):

- Md. - Appliance model
- Sr N. - Equipment serial number (see equipment data nameplate)
- Qr. - Heating output at which the appliance is set
- Qrw. - DHW power at which the appliance is set
- Typ-ins - Type of flue installation (see technical data table)



At the time of installation, the authorised technician must fill in the facsimile of the installation information sticker (Fig. 6) with the information indicated. This sticker is also found inside the warranty unit, must also be filled out and attached to the outside of the unit (visible) (see paragraph 3.2 Initial check).

INSTALLER

USER

MAINTENANCE TECHNICIAN

TECHNICAL DATA



1.4 MAIN DIMENSIONS

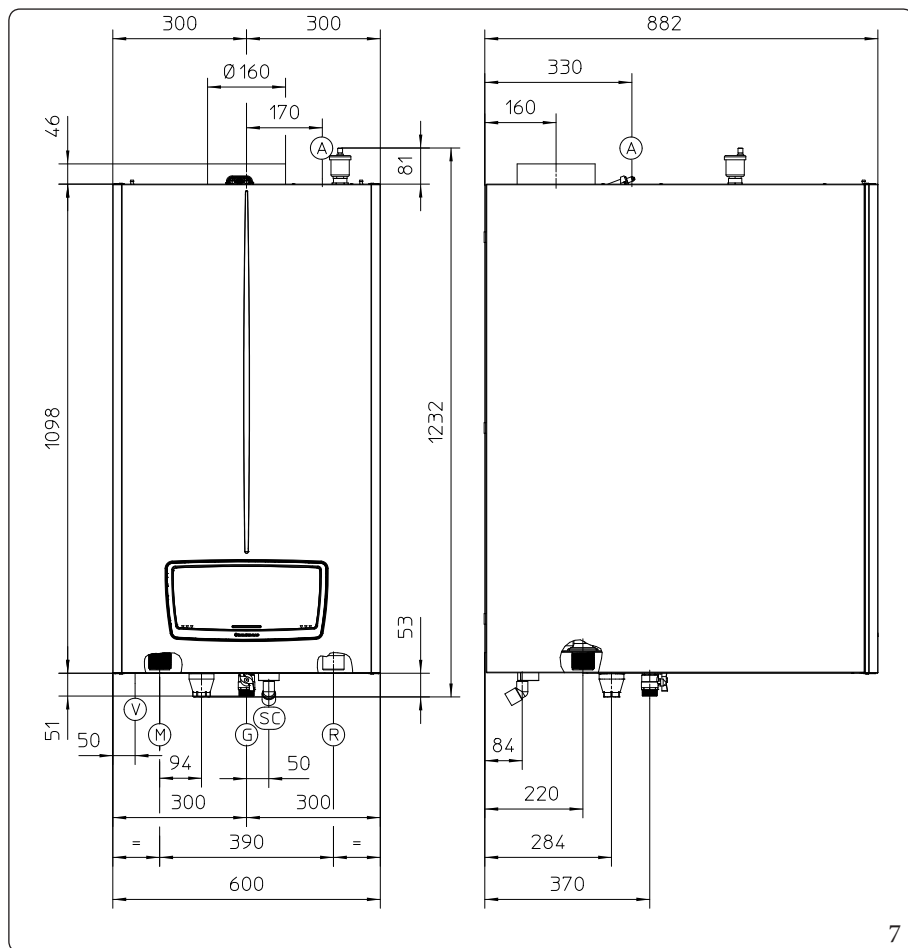

Key (Fig. 7):

- A - Air intake
- V - Electrical connection
- G - Gas supply
- R - System return
- M - System flow
- SC - Condensate drain (minimum internal diameter \varnothing 13 mm)

Model	Height (mm)	Width (mm)	Depth A (mm)
180	1098 (1232)	600	882
Connections			
SMOKE OUTLET	GAS	SYSTEM	
	G	R	M
\varnothing 160	1"	1" 1/2	1" 1/2

1.5 MINIMUM INSTALLATION DISTANCES

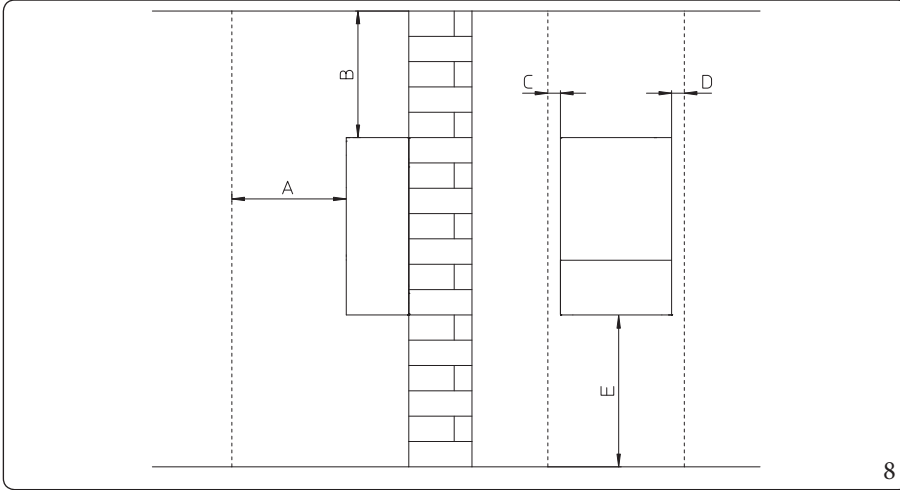

Key (Fig. 8):

- A - 450 mm
- B - 350 mm
- C - 200 mm
- D - 200 mm
- E - 1000 mm

INSTALLER

USER

MAINTENANCE TECHNICIAN

TECHNICAL DATA



1.6 POSITION OF THE APPLIANCES

The devices can be installed:

- outdoors;
- in outdoor environments, also adjoining the building served, located in uncovered space, as long a structurally separated and without walls in common, or situated on the flat covering of the building served, always without walls in common;
- in buildings also destined for other use or in places inserted in the volume of the building served.

These rooms must be intended exclusively to house CH systems and must have characteristics that comply with legislation in force.



The installation of appliances powered with gas with a greater density than 0.8 (L.P.G.) is only allowed in places out of the ground, also communicating with places that are on the ground. In both cases the walkway must not have hollows or depressions such to create gas pockets that determine dangerous conditions.

Height of the installation room

The height of the installation room (for appliances with an output of more than 35 kW) is governed by the technical regulations in force. In addition, special installation conditions must be borne in mind that may require greater heights than the legal minimum.

The following are the guidelines to follow.

- *Installation of an individual appliance:* the minimum height of the room must be 2 m.
- *Installation of several appliances in cascade (2 - 5 Victrix Pro V2):* considering the dimensions of the appliance and the hydraulic manifolds, the minimum height of the room needs to be 2.30 m.

Summary table of room heights as per Ministerial Decree 08/11/2019

Summary table of room heights according to current technical regulations.

Total power	Minimum height external room or reduced height* of the room within the volume of the building served	Minimum room height included in the volume of the building served
≤ 116 kW	≥ 2,00 m	≥ 2,00 m
116 kW < Q _{tot} ≤ 350 kW	≥ 2.00 m (not applicable to 2 to 5 Victrix Pro V2 cascades for dimensional reasons)	≥ 2,30 m
350 kW < Q _{tot} ≤ 580 kW	≥ 2,30 m	≥ 2,60 m
> 580 kW	≥ 2,60 m	≥ 2,90 m

*A reduced minimum room height can be adopted by implementing one of the following measures:

- 100% increase in the total ventilation area compared to that indicated;
- installation of a gas detection system controlling a solenoid valve with manual reset outside the room and optical and acoustic signalling devices.

The aforementioned heights allow for correct installation of the appliances and observe the technical regulations in force.

Position of the appliances in the room

Individual appliance: the distances between any external point of the boiler and the vertical, horizontal walls of the room must allow accessibility to the regulation, safety and control elements and for routine maintenance.

Several appliances, not connected to each other, but installed in the same room: the minimum distance to maintain between several boilers installed on the same wall must be 200 mm, in order to allow accessibility to the regulation, safety and control elements and routine maintenance of all appliances installed.

Installation in cascade (2 - 5 Victrix Pro V2): The instructions for correct installation in cascade are provided in the specific documentation or on the www.immergas.com website in the high power section.



1.7 AERATION AND VENTILATION OF THE INSTALLATION ROOMS

The rooms must have one or more permanent openings for aeration on external walls. The openings used for aeration can be protected using metal grills, meshes and/or rain-proof fins as long as the net aeration surface is not reduced. The aeration openings must be realised and located in a way to prevent the formation of pockets of gas, independently from the conformation of the covering. The resulting total opening may be split in more openings, in all cases each opening must not have a net surface less than 100 cm².

Aeration for installation in outdoor places

The minimum free surfaces, in relation to the overall heat input must not be below:

$$S \geq K \times Z \times Q \text{ (cm}^2\text{)}$$

Where Q is the heat input of the appliance and K and Z are two parameters dependent on the location of the room and the possible presence of gas detection devices. The values of K and Z are given in the table below:

Location of the room	K	Z	
		Standard	If there is a gas detection system that controls a manually reset solenoid valve located outside the room and optical and acoustic signalling devices
Above ground premises	10	1,0	0,8
Basement or underground rooms with a floor level down to -5m	15	1,0	0,9

- **Rooms above ground ($S \geq Q \times 10 \times Z$)**

$S > 1700 \text{ cm}^2$ for each Victrix Pro V2 180 EU ($Z = 1$)

$S > 1360 \text{ cm}^2$ for each Victrix Pro V2 180 EU, in the presence of a gas detection system ($Z = 0.8$)

example: installation of 3 Victrix Pro V2 180 EU in cascade the minimum area S is $1700 \times 3 = 5100 \text{ cm}^2$ or, with gas detection system, $S = 1128 \times 3 = 4080 \text{ cm}^2$.

- **Basement and underground rooms up to -5 m above reference level ($S \geq Q \times 15 \times Z$)**

$S > 2550 \text{ cm}^2$ for each Victrix Pro V2 180 EU ($Z = 1$)

$S > 2295 \text{ cm}^2$ for each Victrix Pro V2 180 EU, in the presence of a gas detection system ($Z = 0.9$)

example: installation of 3 Victrix Pro V2 180 EU in cascade the minimum area S is $2550 \times 3 = 7650 \text{ cm}^2$ or, with gas detection system, $S = 1903.5 \times 3 = 6885 \text{ cm}^2$.



In the case of installation of appliances powered with gas with greater density than 0.8 (L.P.G.) in outdoor places, above-ground, at least 2/3 of the aeration surface must be flush with the floor, with a minimum height of 0.2 m.

The aeration openings must be at least 2 m for heating capacities not exceeding 116 kW and 4.5 m for higher heating capacities, cavities, depressions or openings communicating with rooms below the walkway surface or draining ducts.

Aeration for installation in building also destined for other use or in places inserted in the volume of the building served

The aeration surface must not be less than 3000 cm² in the case of natural gas and must not be less than 5000 cm² in the case of L.P.G.. Consult, and nevertheless always refer to, the provisions and regulations and all legislation in force.



1.8 ANTIFREEZE PROTECTION

Appliance antifreeze protection is thus only ensured if:

- the appliance is correctly connected to gas and electricity power supply circuits;
- the appliance is powered constantly;
- the appliance is not in "off" mode.
- the appliance is not in anomaly conditions (Parag. 2.10);
- the appliance essential components are not faulty.

To prevent the risk of freezing follow the instructions below:

- Protect the central heating circuit from freezing by inserting a good-quality antifreeze liquid into this circuit, which is specially suited for central heating systems and which is manufacturer guaranteed not to cause damage to the heat exchanger or other components of the appliance. The antifreeze liquid must not be harmful to one's health. The instructions of the manufacturer of this liquid must be strictly followed regarding the necessary percentage with respect to the minimum temperature at which the system must be kept.
- The materials used for the central heating circuit of Immergas appliances resist propylene glycol based antifreeze liquids (if the mixtures are prepared perfectly).



The excessive use of glycol could jeopardise the proper functioning of the appliance.



Follow the supplier's instructions for the life cycle duration and possible disposal of the anti-freeze liquid.

- An aqueous solution must be made with potential pollution class of water 2 (EN 1717:2002 or local standards in force).

Minimum room temperature -5°C

The appliance comes as per standard with an antifreeze function that activates the pump and the burner when the system water temperature in the appliance falls below 9°C.



In these conditions, previously listed, the appliance is protected against freezing up to an ambient temperature of -5°C.



If the appliance is installed in a place where the temperature drops below -5°C, the appliance may freeze.



When installing the appliance in locations where the temperature drops below 0°C, insulation of the heating connection pipes, condensate drain pipe and air vent valve of the condensation module is required.

Minimum room temperature -15°C



When installing the appliance in locations where the temperature falls below -5°C, installation of the antifreeze kit is required, respecting all the conditions listed above. !da duplicazione!

Protect the condensate drain siphon against freezing by using an accessory that is supplied on request (antifreeze kit) comprising an electric resistance, the relevant wiring and a control thermostat (carefully read and follow the installation instructions contained in the accessory kit pack).



In the previously listed conditions and with the addition of the antifreeze kit, the appliance is protected against freezing up to a temperature of -15°C.



The antifreeze systems described in this chapter are only to protect the appliance; the presence of these functions and devices does not exclude the possibility of parts of the system outside the appliance from freezing.



The warranty does not cover damage due to interruption of the electrical power supply and failure to comply with that stated on the previous pages.



1.9 OTHER ANTIFREEZE FUNCTIONS (OPTIONALS)

Depending on the system implemented and thus on the optional kits fitted, other Antifreeze functions may be available.

External probe (Optional)

If the external probe is present, the appliance's pump or other pumps if installed (Booster pump, Zone 1 pump, Zone 2 pump, System pump), is activated when the external temperature measured by the probe drops below the temperature set in the parameter "System settings/Additional antifreeze protections/Outside temperature pump activation" (Default -10°C).



In the case of a simple cascade, only the following pumps are activated: Zone 1 pump, Zone 2 pump, System pump).

System sensor (Optional)

If the system sensor is present, the antifreeze function is activated if the temperature measured by the sensor falls below the value of the parameter "System settings/Additional antifreeze protections/Antifreeze activation temperature" (Default 5°C).

Mixed probe (Optional)

If the mixed probe is present, the antifreeze function is activated if the temperature measured by the probe drops below 3°C.

DHW probe (optional)

If the DHW probe is present, the antifreeze function is activated if the temperature measured by the probe falls below 6°C.



For the antifreeze function to work properly, the storage tank must be filled with water; otherwise, the antifreeze can operate continuously.



1.10 GAS CONNECTION

Our appliances are built to work with natural gas (G20), LPG and mixtures of methane and hydrogen at 20% in volume (20%H2NG), referred to the gas distributed in the network. Power supply pipes must be the same as or larger than the appliance fitting.



Before connecting the gas line, carefully clean inside all the fuel feed system pipes to remove any residue that could impair appliance efficiency.

Also make sure the gas corresponds to that for which the appliance is prepared (see appliance data nameplate).

If different, the boiler must be converted for operation with the other type of gas (see converting appliance for other gas types).



It is also important to check the dynamic pressure of the mains (methane or LPG) used to supply the boiler, which must comply with EN 437 and its attachment, as insufficient levels may reduce generator output and cause discomfort to the user. Static/dynamic network pressures higher than those required for regular operation may cause serious damage to the appliance control elements; in this case shut the gas line off.

Do not operate the device.

Have the device checked by experienced personnel.

The gas supply pipe must be suitably dimensioned according to current regulations in order to guarantee correct gas flow rate to the burner even in conditions of maximum generator output and to guarantee appliance efficiency (technical specifications).

For systems with an output of more than 35 kW, a manual shut-off valve must be installed outside of the room in which the appliance is installed on each gas supply pipe, in a visible and easily accessible position, with a quick-closing manoeuvre for 90° rotation and end stops in the fully open or fully closed positions. Such a valve may also be installed in any fire compartment, filter or cavity as long as it is easily accessible from the outside in the event of an emergency.



The appliance is designed to operate with fuel gas free from impurities; otherwise it is advisable to fit special filters upstream of the appliance to restore the purity of the fuel.

Storage tanks (in case of supply from LPG depot).

- New LPG storage tanks may contain residual inert gases (nitrogen) that degrade the mixture delivered to the appliance causing functioning anomalies.
- Due to the composition of the LPG mixture, layering of the mixture components may occur during the period of storage in the tanks. This can cause a variation in the calorific value of the mixture delivered to the appliance, with subsequent change in its performance.

1.11 HYDRAULIC CONNECTION



In order not to void the condensation module warranty, before making the device connections, carefully clean the heating system (pipes, radiators, etc.) with special pickling or descaling products to remove any deposits that could compromise correct device operation.

The current technical standards in force prescribes the washing and treatment of the water in the heating and water system, in order to protect the system and the appliance from deposits (e.g. scale), slurry or other hazardous deposits.

In order not to void the heat exchanger warranty, you are required to comply with what has been prescribed in (Par. 1.61).

Chemical conditioning treatment is always required in relation to the quality of the water used in the water systems for winter heating, with or without domestic hot water production, still following the provisions of the law in force. System water sweetening treatment required for systems with furnaces with heat output greater than 100 kW and supply water with hardness greater than 15 french degrees. Refer to the laws in force for the aforementioned treatments.



The manufacturer is not liable in case of damage caused by the absence of heat and water systems water treatment.



It is recommended to prepare a filter in the system to collect and separate any impurities present in the system (slurry remover filter).

In order to avoid deposits, scaling and corrosion in the central heating system, the provisions set forth in the technical regulation in force on water treatment in heating systems for civil use must be respected.

Hydraulic connections must be made in a rational way using the couplings on the appliance template.

5.4 bar safety valve



The drain of the safety valve must always be properly conveyed to a tundish; consequently, in case of valve operation, the leaked fluid will end up in the sewer system.

Otherwise, the appliance manufacturer declines any responsibility in case of flooding if the drain valve cuts in.



The manufacturer declines all liability in the event of damage caused by the installation of an automatic filling system.

In order to meet the system requirements established by EN 1717 in terms of pollution of drinking water, we recommend installing the anti-backflow kit to be used upstream of the cold water inlet connection of the appliance. We also recommend using category 2 heat transfer fluid (e.g.: water+ glycol) in the appliance's primary circuit (C.H. circuit), as defined in standard EN 1717.

Condensate drain

Condensate must be drained according to the laws in force.

To drain the condensate produced by the appliance, it is necessary to connect to the drainage system by means of acid condensate resistant pipes, with an internal Ø of at least 13 mm.

The system connecting the appliance to the drainage system must be carried out in such a way as to prevent occlusion and freezing of the liquid contained in it.

Before appliance start-up, make sure that the condensate can be correctly removed, in accordance with UNI 11528. after first ignition, check that the drain trap is filled with condensate (Par. 1.50 "Filling the condensate drain trap").

Also, comply with national and local regulations on discharging waste waters.

In the event condensate is not discharged into the wastewater drainage system, a condensate neutraliser must be installed to ensure compliance with the parameters established by the legislation in force.

Installation with system operating at direct low temperature

The appliance can directly feed a low temperature system.

The values of the "Zone 1 CH setpoint" and "Zone 2 CH setpoint" parameters define the maximum flow setpoint of the device; use these parameters to define the maximum system flow setpoint.

The parameters "Zone 1 CH setpoint" and "Zone 2 CH setpoint" modifiable by the User are limited respectively by the parameters "Zone 1 maximum CH setpoint" and "Zone 2 maximum CH setpoint" modifiable only by the Technician (with password). Use the parameters "Zone 1 maximum CH setpoint" and "Zone 2 maximum CH setpoint" to define the maximum system flow setpoint.





During the chimney sweep function, the boiler flow temperature is limited by the parameters “Zone 1 CH setpoint” and “Zone 2 CH setpoint” and the parameter “CH setpoint hysteresis”. When using the 'System side flow sensor', the boiler flow temperature is limited by the maximum permissible temperature (95°C).



If the system-side flow sensor is used, Boiler supply temperature is limited by the maximum permissible temperature (95°C).



To avoid the risk of exceeding the optimal temperature of operation in low temperature, due to external causes (e.g.: incorrect adjustment, prolonged non-use of the system, etc.), you must insert in series with the supply voltage of the boiler, a special safety kit (optional) consisting of a thermostat (with adjustable temperature, depending on the characteristics of the system). The thermostat must be positioned on the system flow pipe at a distance of more than 2 metres from the boiler.



1.12 ELECTRICAL CONNECTION



The electrical system must be built in compliance with technical standards and all legislation in force.

The appliance has an IPX5D protection degree; electrical safety of the appliance is achieved only when it is connected properly to an efficient earthing system, as specified by current safety standards.



The manufacturer declines any responsibility for damage or physical injury caused by failure to connect the appliance to an efficient earthing system or failure to comply with the local reference standards.



Opening the front control panel cover for access to the P.C.B. and display board (Fig. 9).



The power supply cable must be connected to a 230V $\pm 10\%$ / 50Hz mains supply respecting L-N polarity and earth connection; this network must also have a multi-pole circuit breaker with class III overvoltage category in compliance with installation regulations.

To access the P.C.B. and display board, it is necessary to dismantle the front casing (Par. 3.19) and follow the instructions below:



Disconnect power to the unit before making any electrical connections.

1. Press on the two hooks (b) at the top of the front control panel cover (a);
2. When releasing the front control panel lid (a), accompany its rotation until it is fully open, in order to access the P.C.B. (c) and display board (d).

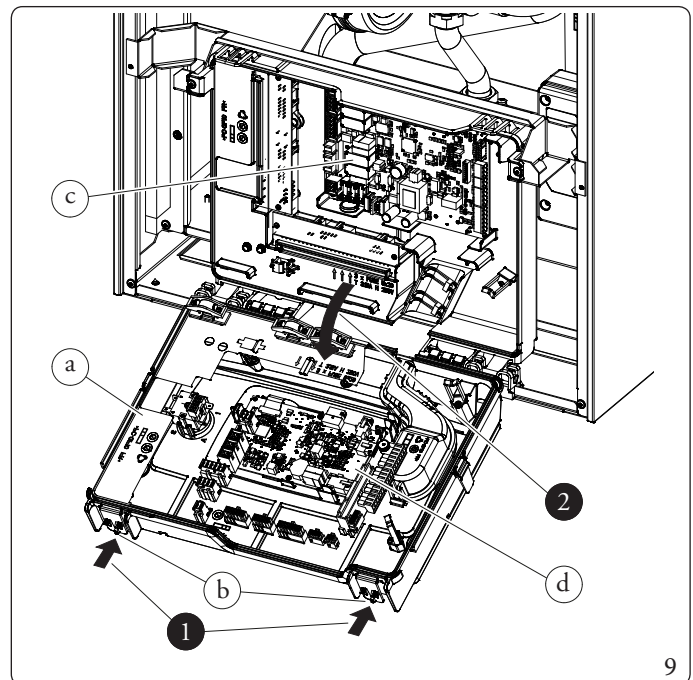

Rear control panel cover opening for access to low power connection board Victrix Pro V2 and high power connection board Victrix Pro V2 (Fig. 10, 11).

In order to access the electrical connection boards, it is necessary to dismantle the front casing (Par. 3.19) and follow the instructions below:

1. Then unscrew the two fixing screws (b) on the control panel (a);
2. Rotate the control panel (a) until it is fully open;
3. Unscrew the four screws (c) of the rear cover in order to access the high power board (d) and low power board (e).



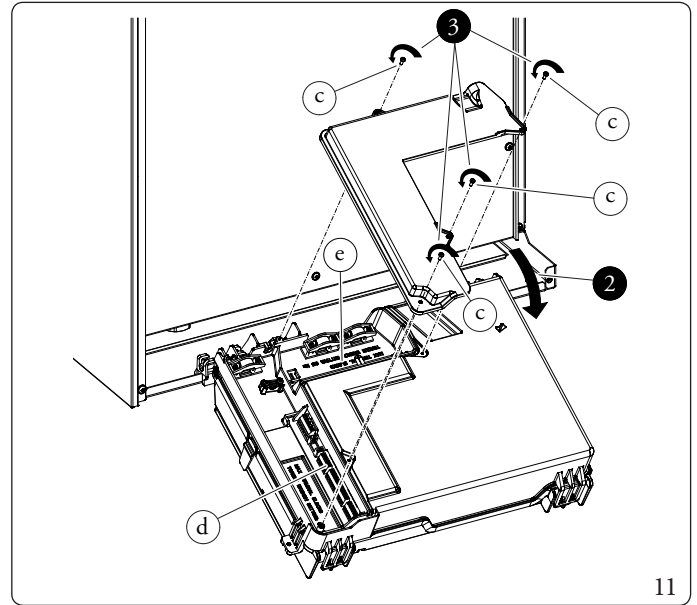
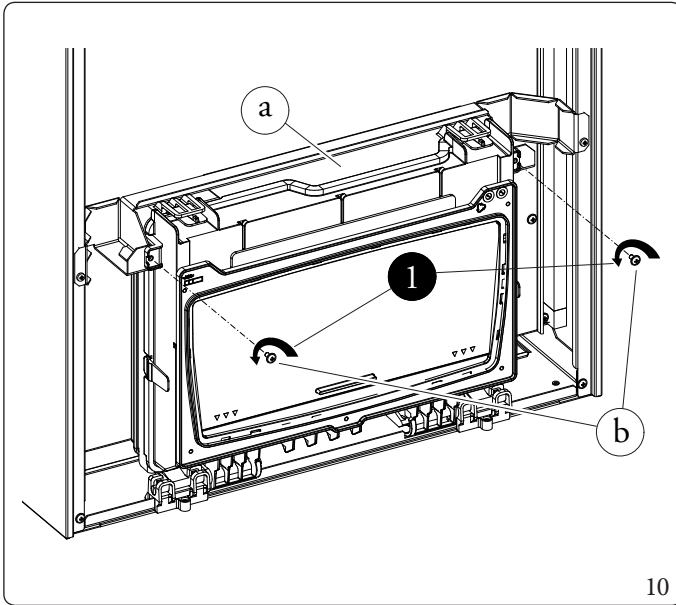

Also ensure that the electrical installation corresponds to maximum absorbed power specifications as shown on the appliance data nameplate.

Boilers are supplied complete with a special “X” type power cable without plug.

The main switch must be installed outside the rooms in a position that is indicated and accessible.



To protect from possible dispersions of DC voltage, it is necessary to provide a type A differential safety device.



If the power supply cable is damaged, it must be replaced by a special cable or assembly, which are only available from the manufacturer or its Authorised After-Sales Technical Assistance Centre.

The power supply cable must be laid as shown (Fig. 12).

If the fuses on the circuit boards need to be replaced, this must also be done by qualified personnel.

The appliance is equipped with four boards: a circuit board (A2), a connection sheet (loads) (A37), a display board (A4) and a connection card (signals) (A38).

There are three fuses on the circuit board (A2): 5x20 T 3.15 A H 250V (F1, F2, F4).

The fuse on the connection board (A37) is type 5x20 6.3 A F 250V (F5).

For the main power supply to the appliance, never use adapters, multiple sockets or extension leads.

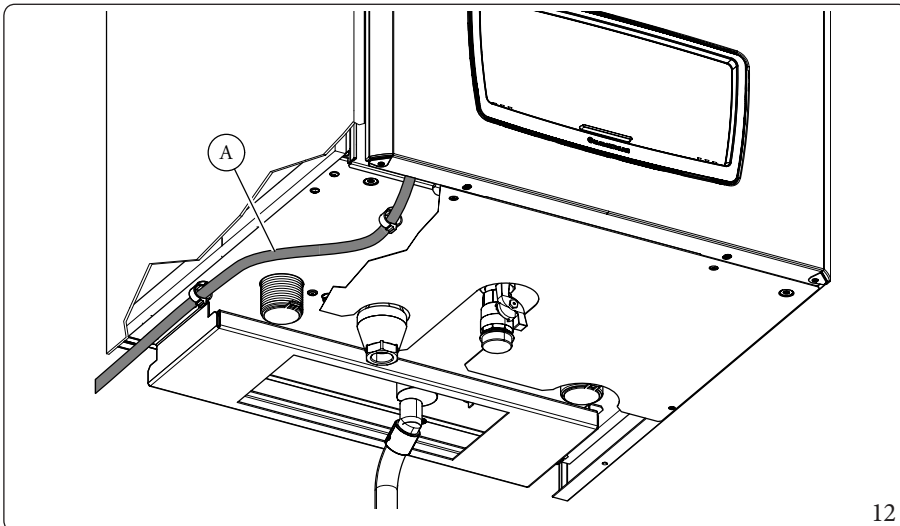



Key (Fig. 12):

A - Powersupply cable

1.13 COMMANDS FOR HEAT ADJUSTMENT (OPTIONAL)

The appliance is designed for the application of the Victrix Pro V2 cascade and zone regulator kit, the Victrix Pro V2 zone manager kit, the remote control for single high-power boilers, on/off thermostats, commercial OpenTherm modulators and the external probe. These components are available as separate kits to the boiler and are supplied on request. Carefully read the user and assembly instructions contained in the accessory kit.

 For the temperature control commands to work properly, the appliance must not be put on standby.

 Make sure that the OpenTherm thermostat is compatible with the appliance.

 For the cascade and zone regulator and the remote control for single high-power boilers, the CLIP IN (Optional) must be added for each appliance.

 **Disconnect power to the unit before making any electrical connections.**

CH demand type

- **Climatic curve outside temperature and room thermostat**

It is used in the case of an external probe with room thermostat ON/OFF or OpenTherm (see also climate curve). If the room thermostat ON/OFF is used, the CH schedule and holiday mode can be used.

- **Room thermostat setpoint (default)**

It is used with room thermostat ON/OFF or OpenTherm.

The external sensor can be connected, but without being used by the appliance, for CH setpoint control but is used in the following cases:

- OpenTherm;
- Cascade and zone regulator;
- BMS.

and in the heating deactivation function during the summer period (see parameter "Outside temperature for CH off"). When using the room thermostat ON/OFF, the Scheduler set heating and Holiday mode can be used.

- **Only OTC**

It is used when an external sensor is present but the CH demand is permanently generated on both heating zones (it is not mandatory to configure both pumps of the two zones) (see also climate curve). Inputs OT1 - OT2 and OT3 - OT4 (in this case), can be used as setpoint reduction (contact closed). With open contact, the setpoint used is given by the parameters "Zone 1 CH setpoint" and "Zone 2 CH setpoint". With closed contact, a setpoint reduction is implemented (see parameters "Zone 1 CH ECO setpoint reduction" and "Zone 2 CH ECO setpoint reduction"). The minimum setpoint is however limited by the parameters "Zone 1 minimum CH setpoint" and "Zone 2 minimum CH setpoint". As an alternative to using inputs OT1 - OT2 and OT3 - OT4, the schedule can be used (it is recommended to keep contacts OT1 - OT2 and OT3 - OT4 open even if the closed contacts have no effect).

With timeslot "ON" the setpoint used is given by the parameters "Zone 1 heating setpoint" and "Zone 2 heating setpoint".

With time slot "ECO", a setpoint reduction is implemented (see parameters "Zone 1 CH ECO setpoint reduction" and "Zone 2 CH ECO setpoint reduction"). In this case, if the setpoint is lower than the value of the parameters "Zone 1 minimum CH setpoint" and "Zone 2 minimum CH setpoint", the CH demand is inhibited.

With time slot "OFF" the CH demand is inhibited.

 The function "ECO" activated via button "ECO", does not activate the setpoint reduction.



- **Constant Setpoint**

The CH demand is generated permanently on both heating zones (it is not mandatory to configure both pumps of the two zones). Inputs OT1 and OT2 (in this case), can be used as setpoint reduction (open contact). With closed contact, the setpoint used is given by the parameters "Zone 1 CH setpoint" and "Zone 2 CH setpoint". With open contact, a setpoint reduction is implemented (see parameters "Zone 1 CH constant setpoint reduction" and "Zone 2 CH constant setpoint reduction"). The schedule has no influence (although the icon appears on the main screen). The minimum setpoint is however limited by the parameters "Zone 1 minimum CH setpoint" and "Zone 2 minimum CH setpoint".

- **0-10 V power control**

The CH demand is controlled in power.



Inputs OT1-OT2 and OT3-OT4 must not be closed.



See relevant section for more details.

- **Temperature control 0-10V**

The CH demand is controlled via the setpoint.



Inputs OT1-OT2 and OT3-OT4 must not be closed.



See relevant section for more details.

Victrix Pro V2 cascade and zone regulator



The old cascade and zone regulator is compatible with Victrix Pro V2 models.

The cascade and zone regulator is connected to the boiler using only two wires, powered at 230 V and allows to:

- manage a hydraulic circuit with up to 4 mixed zones (mixing valve) with additional boards; 1 direct zone; 1 Storage tank unit and relative pumps;
- self-diagnosis system to display any boiler functioning anomalies;
- set two room temperature value: one for day (comfort temperature) and one for night (reduced temperature);
- to manage the temperature of the DHW (with a storage tank unit);
- to manage the boiler flow temperature depending on the external temperature;
- to select the desired operating mode from the various possible alternatives for each individual hydraulic circuit:
 - permanent operation in comfort temperature;
 - permanent operation in reduced temperature;
 - permanent operation in adjustable anti-freeze temperature.



If the cascade and zone regulator is used, it is mandatory to prepare separate lines with different supply voltage; it is essential to separate the low voltage connections from the 230 V ones. All appliance pipes must never be used for earthing the electrical or telephone system. Ensure elimination of this risk before making the appliance electrical connections.

Victrix Pro V2 zone manager

The climate chrono-thermostat that can be coupled to the cascade and zone regulator enables the system flow temperature to be adjusted to the actual needs of the room being heated, in order to obtain the desired room temperature with extreme precision and therefore with evident saving in running costs. It also allows the room temperature to be displayed.

The zone manager is powered directly by the cascade and zone regulator via 2 wires.

High power remote control for single boiler

The remote control for single high-power boilers connects to the single boiler or to the master boiler of the simple cascade (manages only one central heating and DHW zone).

The CH and DHW setpoint are managed by the remote control but are limited by the appliance parameters.

If you disable the DHW demand from remote control, this action will only be effective after the DHW demand itself is completed.

Electrical connection of Victrix Pro V2 cascade and zone regulator and high-power remote control for single boiler

Thermoregulation electrical connections must be carried out on the boiler terminal board eliminating link X40.

Cascade and zone regulator: must be connected through terminals A and B to terminals "M" and "O" respecting polarity. The connection with incorrect polarity will not damage the temperature controller, but will not allow it to operate (Fig. 69).



When connecting the high power remote control for single boilers, the address of the CLIP IN must be set to '0'; it is then automatically powered.



When the cascade and zone regulator is connected, it is recommended to set the address of a CLIP IN to '0'. This helps to make the communication BUS more immune to disturbances.

BMS mode (Building Management System)

When the BMS is activated and operational, the icon  is displayed (Control panel).

The device connected to the BMS must be controlled it alone and not by other modes (Opentherm, 0-10V, Cascade and zone regulator, room thermostat, parameter "CH Request type" and "DHW request type").



If the BMS must be integrated into an existing home automation system or other than the Immergas system manager, the Authorised Technical Assistance Centre must be contacted for the configuration of the correct parameters.

Opentherm

When Opentherm is activated and running, the icon  is displayed.

The device connected to the Opentherm must only be controlled by it and not by other modes (BMS, 0-10V, cascade and zone controller, room thermostat).

It is important that the parameter "CH Request type" be set as Room thermostat setpoint.



Make sure that the OpenTherm thermostat is compatible with the appliance.



It is preferable that the Opentherm thermostat does not manage the DHW function but that this is managed locally. The Opentherm thermostat can still manage the activation/deactivation of the DHW function.



The functions "ECO" and "Holiday mode" are not active with Opentherm.

On/Off room thermostat or chrono-thermostat and Opentherm electrical connection

The On/Off room thermostat or chrono-thermostat is connected to terminals 'OT1' and 'OT2' in the case of connection to Zone 1 and 'OT3' and 'OT4' in the case of connection to Zone 2. Make sure that the On/Off thermostat contact is "dry", i.e. independent of the mains voltage, otherwise the P.C.B. would be damaged.

Ensure that polarity is observed when connecting the Opentherm.

Input 0/10V

The microprocessor has an analogue 0 ÷ 10 V inlet (terminals "Y" and "Z") that enables the boiler to be controlled from the outside.



Terminal Y is already internally connected to GND and is therefore referenced to earth.



By setting the parameter "CH Request type" within "HYDRAULIC SETTINGS" it is possible to configure the input by choosing the operating mode between "0-10 V Temperature control" and "0-10 V Power control".

By setting this parameter, both in temperature and in Power, the CH demand is subject to priority in DHW, deactivation CH Demand, Decreasing slope (function) and Minimum time.

As the voltage at the input increases, a CH Demand is activated. In the range between 2 V (minimum) and 10 V (maximum), the temperature or power setpoint will be proportional to the voltage.

As the voltage decreases from 2 V to 1 V, CH Demand is the minimum, while below 1 V, the demand is deactivated.

Power

With the default values of the parameter "Power set" (central heating), at 2 V, the power of the device will be set to the parameter "Minimum power", at 10 V, it will be set to the parameter "Maximum power" and at intermediate points, a proportional value between the two parameters just described.

In the event that one or both parameters of the power setting are different from the default value, the proportionality of the straight line will be identical to the case described above, but the Minimum power of the device can never assume values lower than the parameter "Minimum power" while the Maximum power of the device can never assume values greater than the parameter "Maximum power" (it goes without saying that the voltage range remains between 2 V and 10 V).

During power operation, the temperature set is the one set in parameter "Zone 1 CH setpoint".

Temperature

The temperature setpoint (CH) is related to the voltage as described below:

at 2 V, the setpoint will be set to the parameter "Zone 1 minimum CH setpoint", at 10 V, it will be set to the parameter "Zone 1 CH setpoint" and at intermediate points, a proportional value between the two parameters just described.



In case the 0-10 V input can be floating, the voltage at the input is 2.5 V, which results in a demand. To avoid this, connect a resistance in parallel to the input. This resistance must be between 2.2 kOhm and 50 kOhm (4.7 kOhm recommended). If one of the two parameters "CH Request type" is not selected, no CH Demand is generated, while leaving this input floating.

External temperature probe

The appliance is prepared for the application of the external probe (Fig. 13), which is available as an optional kit.

Refer to the relative instruction sheet for positioning of the external probe.

The probe can be connected directly to the appliance electrical system and allows the max. system flow temperature to be automatically decreased when the external temperature increases, in order to adjust the heat supplied to the system according to the change in external temperature.

The electric connection of the external probe must take place on clamps G and J on the connection board in the boiler (Fig. 69).

By default the external probe is not enabled, you must set the parameters in the "TECHNICIAN", "HYDRAULIC SETTINGS", "CH demand type" menu for its correct operation. The correlation between system flow temperature and outside temperature is independent for the two zones and is determined by four points and the offset.

The correlation between system flow temperature and outside temperature is determined by the curves shown in the graphs (Fig. 14, 15).

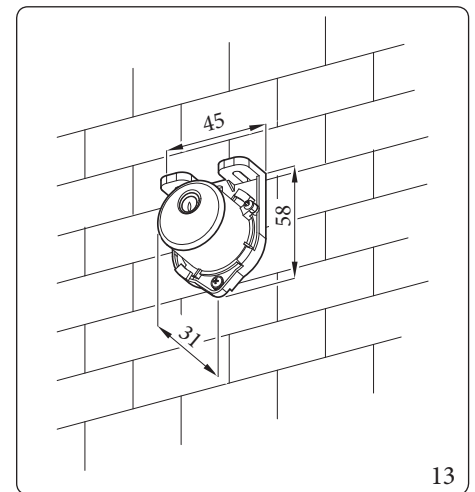

The external probe may be used with the cascade and zone regulator by connecting it on the regulator or on the boiler (attention: the code of the external probe changes if it is connected to the regulator or the boiler); for specific installations refer to the diagrams in Fig. (69), while for the high power thermostat use the probe connected in the boiler.

If the external probe is connected to the boiler, the 'CH demand type' parameter must be set as 'Room thermostat setpoint'; with this setting, the management of the probe itself is delegated to the cascade and zone regulator and the high-power thermostat.



See also Parag. 2.7 and Parag. 2.8.

- OTCclimatecurve-CH1 (Zone 1 CH)

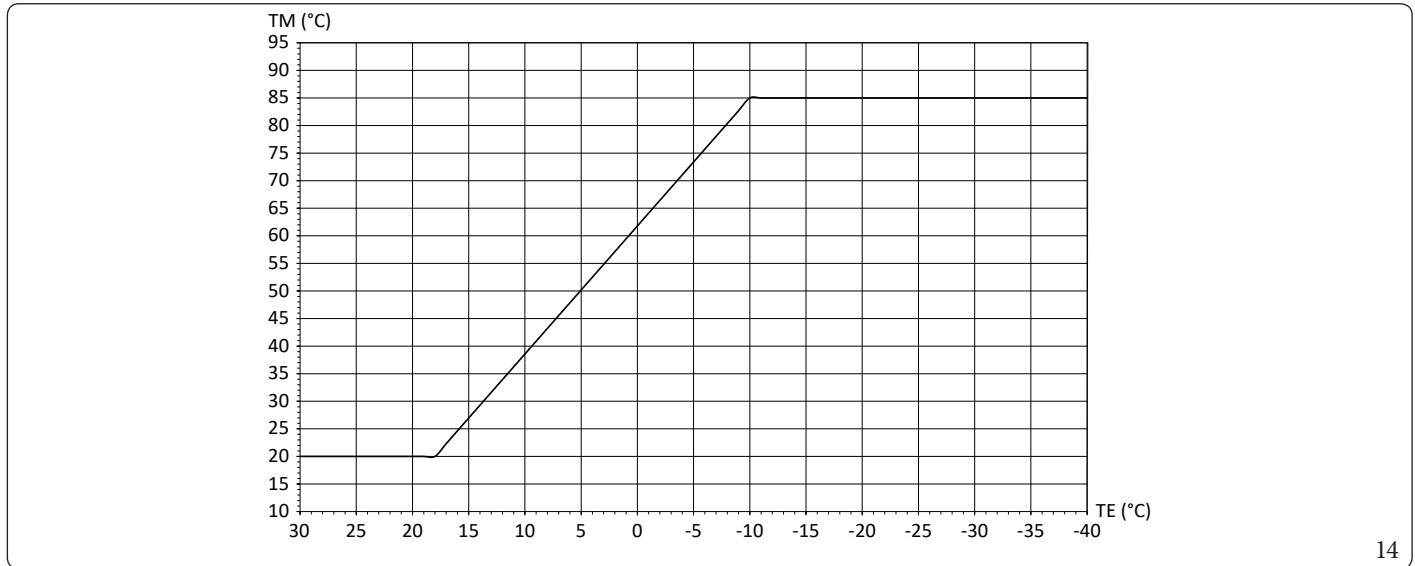

14

The graph in fig. 14 is made by comparing the Outside temperature for min CH value (+18 °C) with the Zone 1 minimum CH setpoint value (+20 °C) and the Outside temperature for max CH value (-10 °C) with the Zone 1 CH setpoint value (+85 °C).

The parameter Zone 1 Offset decreases or increases the setpoint calculated via the straight line of the climate curve shown in the graph in Fig. 14 but the setpoint is still limited by the parameters Zone 1 CH setpoint and Zone 1 minimum CH setpoint.



The parameter "Zone 1 maximum CH setpoint" limits the parameter "Zone 1 CH setpoint".

- OTCclimatecurve-CH2 (Zone 2 CH)

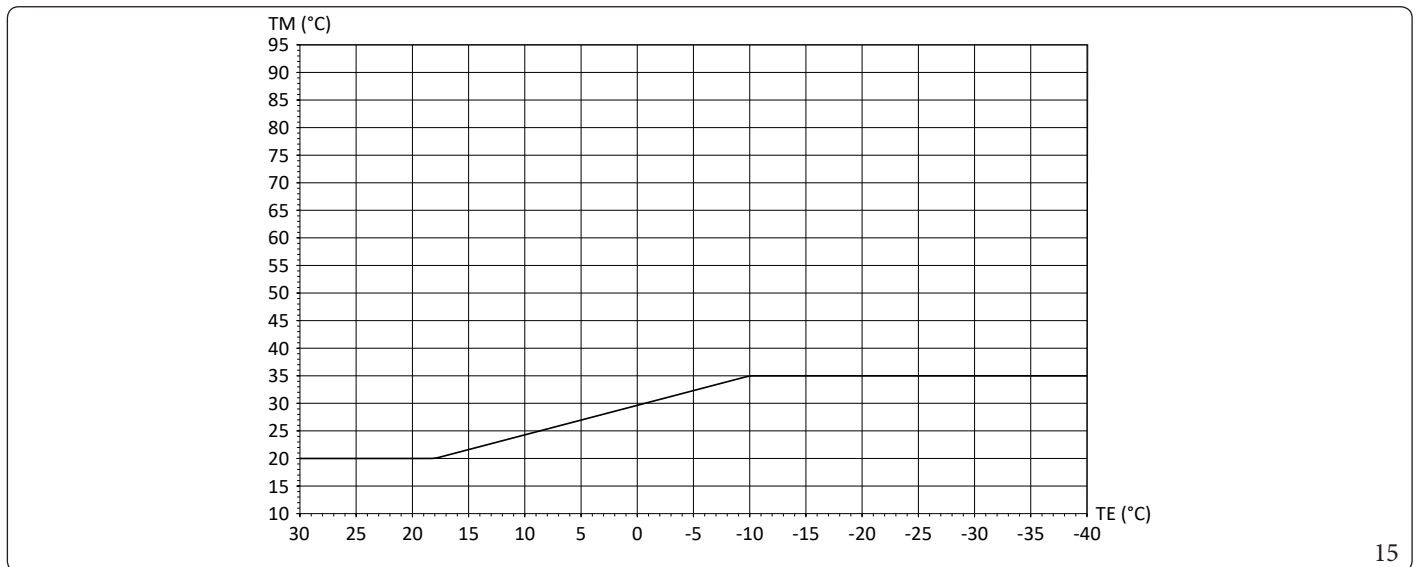

15

The graph in fig. 15 is made by comparing the Outside temperature for min CH value (+18 °C) with the Zone 2 minimum CH setpoint value (+20 °C) and the Outside temperature for max CH value (-10 °C) with the Zone 2 CH setpoint value (+35 °C).

The parameter Zone 2 Offset decreases or increases the setpoint calculated via the straight line of the climate curve shown in the graph in Fig. 15 but the setpoint is still limited by the parameters Zone 2 CH setpoint and Zone 2 minimum CH setpoint.



The parameter "Zone 2 maximum CH setpoint" limits the parameter "Zone 2 CH setpoint".



1.14 HYDRAULIC SETTINGS

System sensor



Two heating zones (one of which can be mixed) and a DHW storage tank can be managed.

Relay settings



See also Relay settings in chapter Maintenance.

Using the configurable relays, the hydraulic diagrams shown on the following pages can be realised.



These relays can be used to activate the zone pumps, System pump, DHW pump, Booster pump, 3-way valve DHW, mixing valve, appliance faulty warning and Burner on.

CH Request type

Through this parameter, "CH Request type" is configured from among the six possible and visible in the menu and in the following diagrams.

DHW request type

With this parameter, the DHW request with thermostat (dry contact) or sensor is configured.

Parallel mode

This mode allows simultaneous operation of CH and DHW (preventing the CH demand from being excluded from the DHW priority).



The hydraulic system must be adjusted because during simultaneous operation, the appliance operates with the DHW setpoint.



The power range of the system is between the lowest and highest value of the parameters "Minimum power" and "Maximum power" for CH and DHW in order to obtain the widest range of power regulation.



In the case of simultaneous CH and DHW demands, the setpoint displayed on the main screen may not be precise with the current operation.

Manual relay test

In the technical menu, there is a function for testing the actuator control relays, which were previously configured in the appropriate menu.



During the relay test, the burner must be switched off and the relays may only be operated individually.

1.15 NOTES AND TABLES IN COMMON OF WIRING DIAGRAMS



The notes and tables below apply to all diagrams in fig. 17, 18, 19, 20, 21, 22, 23, 24, 25, 27, 28, 29, 30, 31, 32, 33, 34.



For low-temperature zones, insert a safety thermostat in series with the relevant zone pump.

Remove the X40 link in case of connection:

- * cascade and zone regulator
- * 0-10V
- * BMS
- * BUSOT
- * Some types of CH demand (parameter "CH Request type", menu "HYDRAULIC SETTINGS")
- * Room thermostat ON/OFF

Electrical Connections (Signals)				
Components	Cable cross-section (mm ²)		Cable diameter (mm)	Maximum length (m)
	minimum	maximum		
* B1-2 * B2 * B3 * S50 * 0-10V	0,5	1,5	5-7	25 (2x25)
* B4 * S20-1 * S20-2 * OpenTherm				50 (2x50)
* External reset				10 (2x10)
* A27	J-Y(ST)Y 2x0,6			50 (2x50)



Screw terminal blocks for electrical connection (loads) accept a maximum cable cross-section of 1.5 mm² and a minimum of 0.5 mm².

Maximum loads on relays of boards A2 and A4				
Multi-function relays	Voltage	Current	cosφ	Notes
K70-A2/K70-A3 - K70-A4/K70-A5 K70-A1	230 Vac	<0,1 A	≥0,6	From factory settings, K70 relays do not perform any functions.
K70-A6/K70-A7	Potential-free contact (230 Vac MAX)	<0,1 A	≥0,6	Insert an optional external relay to drive each load.

OpenTherm:

- When using an OpenTherm thermostat, set the parameter "CH Request type" as "Room thermostat setpoint";
- ensure that the OpenTherm thermostat is compatible with the boiler.



When configuring the mixing valve, use the relays on the main board (relays K70-A1 to K70-A5) or on the display board (relays K70-A6 and K70-A7).
Do not use a relay on the main board and one on the display board.



1.16 HYDRAULIC DIAGRAM - ONE DIRECT ZONE - ONE MIXED ZONE - 3-WAY VALVE - HYDRAULIC MANIFOLD (ONE APPLIANCE)

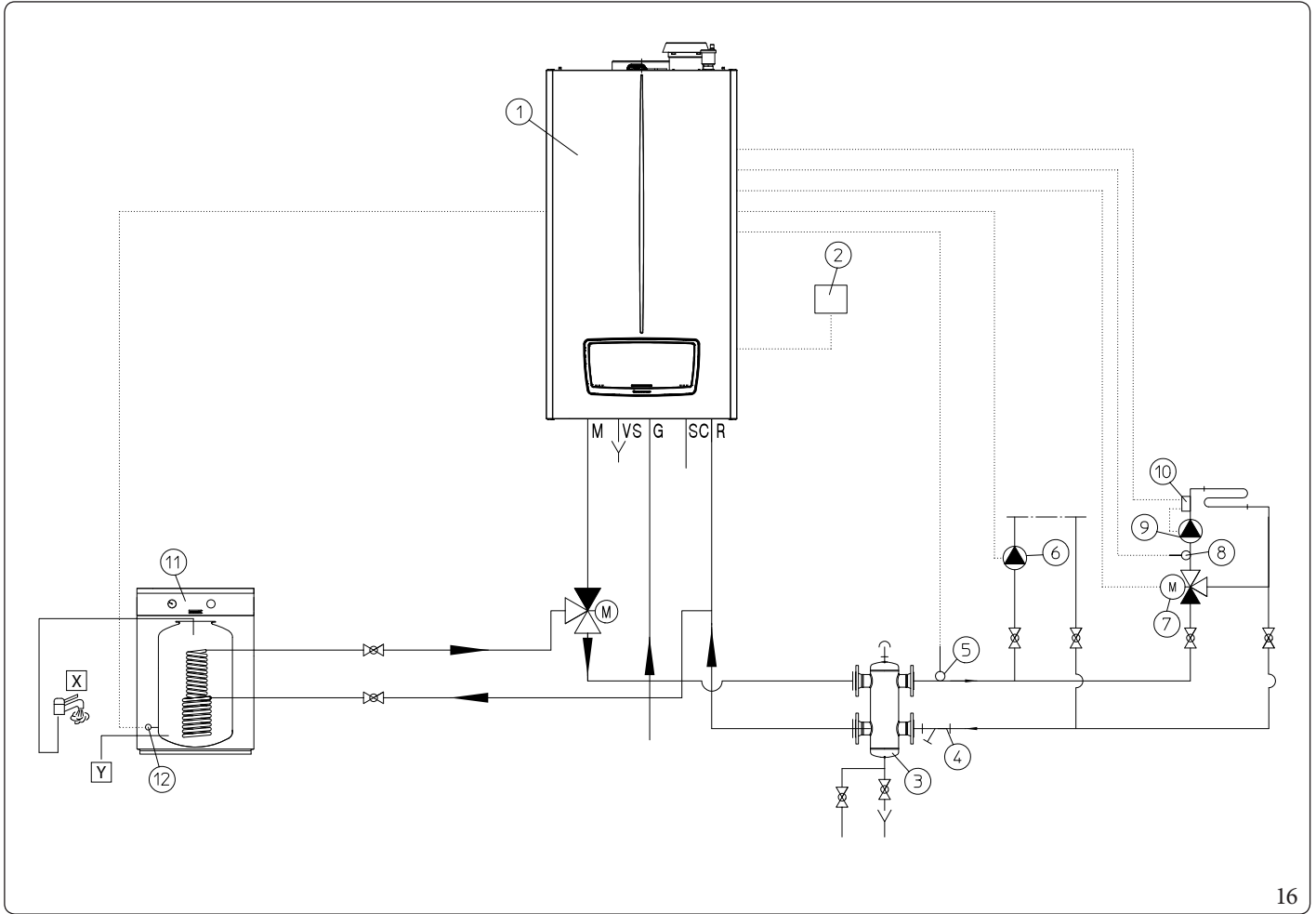

16

Key (Fig. 16):

- | | |
|-------------------------------------|---|
| 1 - Generator | 9 - Minimum pressure switch with manual reset |
| 2 - External probe | 10 - Safety thermostat |
| 3 - Manifold/mixer | 11 - Storage tank unit feeding pump |
| 4 - Slurry collection system filter | 12 - Non return valve |
| 5 - Common flow probe | 13 - External storage tank unit |
| 6 - Direct circuit pump | 14 - Storage tank unit temperature probe |
| 7 - Mixing valve | X - Hot water |
| 8 - Pressure gauge | Y - Cold water |

1.17 WIRING DIAGRAM - ONE DIRECT ZONE - ONE MIXED ZONE - 3-WAY VALVE - HYDRAULIC MANIFOLD (ONE APPLIANCE)



See wiring diagram (Parag. 1.17)



Further notes on this diagram can be found in parag. 1.15.
As a hydraulic diagram, please refer to fig. 16.

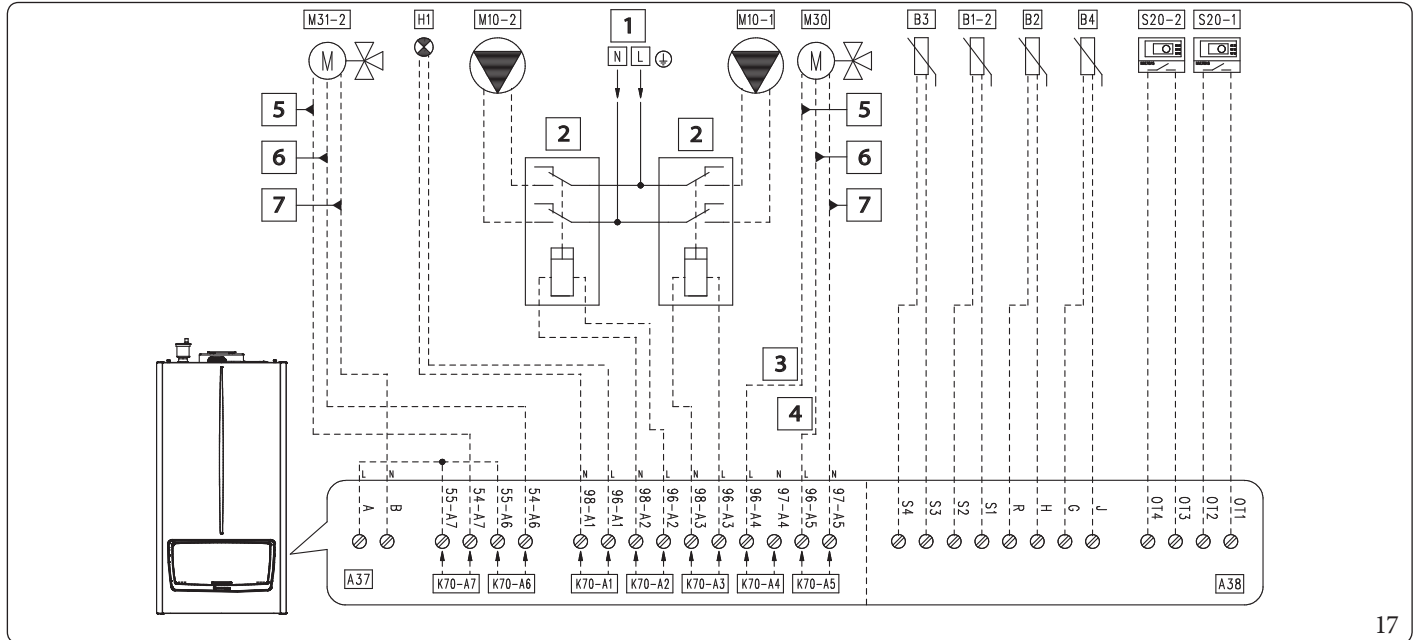

17

Parameter configuration table "HYDRAULICSETTINGS" (Technician menu)	
Parameter/menu name	Setting
Submenu "Relay settings":	
- K70-A1	- System fault
- K70-A2	- Zone 2 pump
- K70-A3	- Zone 1 pump
- K70-A4	- 3-way valve DHW
- K70-A5	- 3-way valve CH
- K70-A6	- Mixing valve: opens
- K70-A7	- Mixing valve: closes
- System pump configuration	- not used
- System sensor	- CH mode
Submenu "Mix zone":	
- Mix zone selection	- 2
- Valve travel time	- 150
- CH Request type	- Room thermostat OTC
- DHW request type	- Sensor
- Parallel mode	- Disabled
Submenu "3-way valve":	
- 3-way valve selection	- Motorized
- Travel time	- 12
- Default position	- CH
Note: If you want to use Zone 1 as a mixed zone and Zone 2 as a direct zone, you have to set the parameter "Mix zone selection" to "1", then you have to set the setpoints of zone 1 and zone 2 correctly.	

Key (Fig. 17):

- A37 - Connection sheet (loads)
- A38 - Connection card (signals)
- B1-2 - System flow sensor (NTC) (optional)
- B2 - Domestic hot water probe (NTC) (optional)
- B3 - Low temperature (NTC) probe (optional)
- B4 - External probe (NTC) (optional)
- H1 - Indicator light "ERROR" (230 Vac) (optional)
- M10-1 - Zone 1 circulator pump (optional)
- M10-2 - Zone 2 circulator pump (optional)
- M30 - 3-way valve (optional)
- M31-2 - Zone 2 mixing valve (Optional)
- S20-1 - Zone 1 room thermostat (optional)
- S20-2 - Zone 2 room thermostat (optional)
- 1 - 230 Vac - 50 Hz
- 2 - External relay (optional) - Coil 230 Vac Max. 0.1 A
- 3 - Domestic hot water
- 4 - Central heating
- 5 - Close
- 6 - Open
- 7 - Common

INSTALLER

USER

MAINTENANCE TECHNICIAN

TECHNICAL DATA



1.18 WIRING DIAGRAM - ZONE 2 MIXED HEATING - 3-WAY VALVE - HYDRAULIC MANIFOLD (ONE APPLIANCE)



Further notes on this diagram can be found in parag. 1.15.
As a hydraulic diagram, please refer to fig. 16.

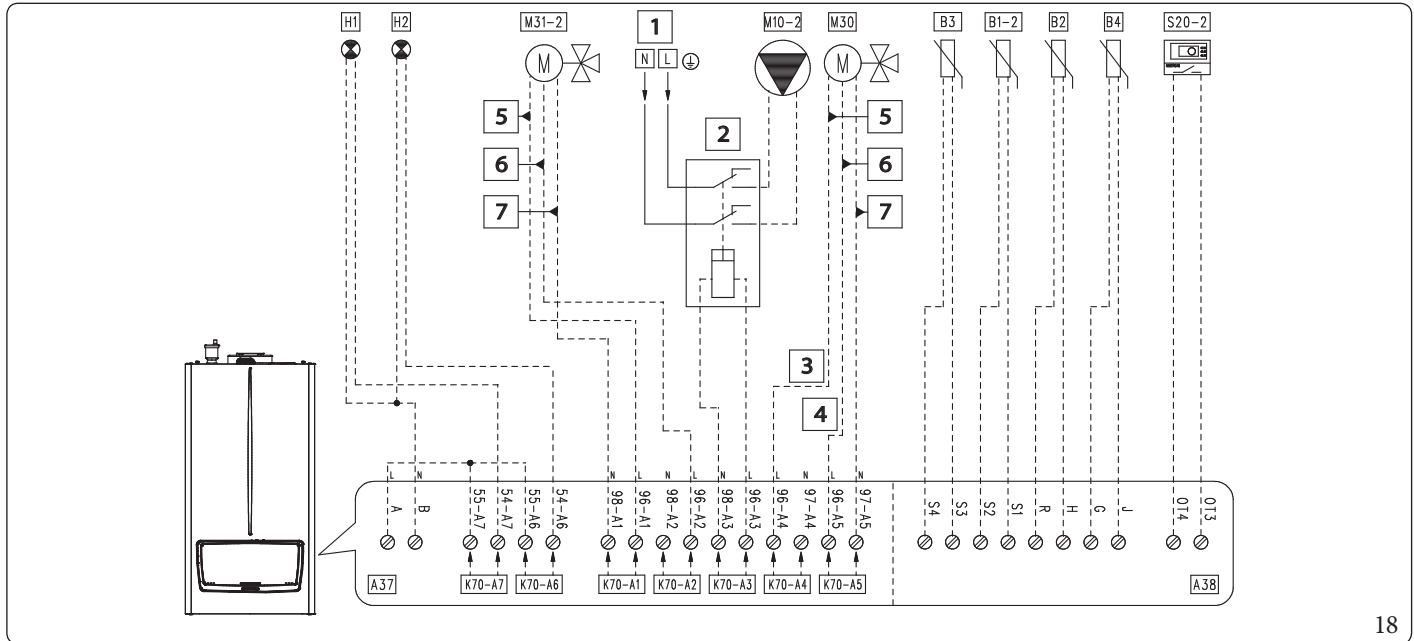

18

Parameter configuration table

"HYDRAULIC SETTINGS" (Technician menu)

Parameter/menu name	Setting
Submenu "Relay settings":	
- K70-A1	- Mixing valve: closes
- K70-A2	- Mixing valve: opens
- K70-A3	- Zone 2 pump
- K70-A4	- 3-way valve DHW
- K70-A5	- 3-way valve CH
- K70-A6	- Burner on
- K70-A7	- System fault
- System pump configuration	- not used
- System sensor	- CH mode
Submenu "Mix zone":	
- Mix zone selection	- 2
- Valve travel time	- 150
- CH Request type	- Room thermostat OTC
- DHW request type	- Sensor
- Parallel mode	- Disabled
Submenu "3-way valve":	
- 3-way valve selection	- Motorized
- Travel time	- 12
- Default position	- CH
Note: If you want to use zone 1 as a mixed zone, set the parameter "Mix zone selection" to "1", the parameter "K70-A3" as "Zone 1 pump", connect the room thermostat to the screw terminals "OT1" and "OT2" and set the setpoints of zone 1 correctly.	

Key (Fig. 18):

- A37 - Connection sheet (loads)
- A38 - Connection card (signals)
- B1-2 - System flow sensor (NTC) (optional)
- B2 - Domestic hot water probe (NTC) (optional)
- B3 - Low temperature (NTC) probe (optional)
- B4 - External probe (NTC) (optional)
- H1 - Indicator light "ERROR" (230 Vac) (optional)
- H2 - Indicator light "Burner on" (230 Vac) (optional)
- M10-2 - Zone 2 circulator pump (optional)
- M30 - 3-way valve (optional)
- M31-2 - Zone 2 mixing valve (Optional)
- S20-2 - Zone 2 room thermostat (optional)
- 1 - 230 Vac - 50 Hz
- 2 - External relay (optional) - Coil 230 Vac Max. 0.1 A
- 3 - Domestic hot water
- 4 - Central heating
- 5 - Close
- 6 - Open
- 7 - Common



1.19 WIRING DIAGRAM - ZONE 2 MIXED HEATING- 3-WAY VALVE - WITHOUT HYDRAULIC MANIFOLD (ONE APPLIANCE)



Further notes on this diagram can be found in parag. 1.15.
As a hydraulic diagram, please refer to fig. 16.

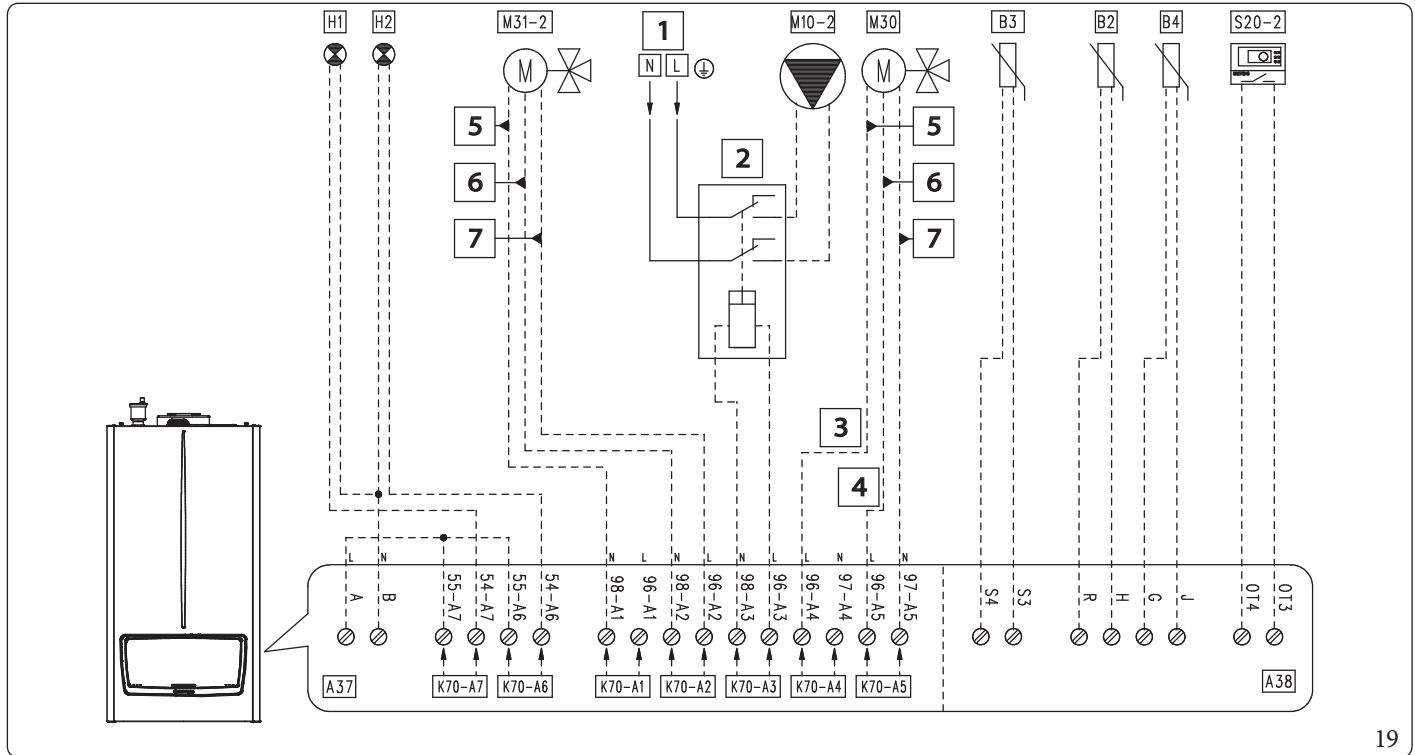

19

Parameter configuration table "HYDRAULICSETTINGS" (Technician menu)	
Parameter/menu name	Setting
Submenu "Relay settings":	
- K70-A1	- Mixing valve: closes
- K70-A2	- Mixing valve: opens
- K70-A3	- Zone 2 pump
- K70-A4	- 3-way valve DHW
- K70-A5	- 3-way valve CH
- K70-A6	- Burner on
- K70-A7	- System fault
- System pump configuration	- not used
- System sensor	- CH mode
Submenu "Mix zone":	
- Mix zone selection	- 2
- Valve travel time	- 150
- CH Request type	- Room thermostat OTC
- DHW request type	- Sensor
- Parallel mode	- Disabled
Submenu "3-way valve":	
- 3-way valve selection	- Motorized
- Travel time	- 12
- Default position	- CH
Note: If you want to use zone 1 as a mixed zone, set the parameter "Mix zone selection" to "1", the parameter "K70-A3" as "Zone 1 pump", connect the room thermostat to the screw terminals "OT1" and "OT2" and set the setpoints of zone 1 correctly.	

Key (Fig. 19):

- A37 - Connection sheet (loads)
- A38 - Connection card (signals)
- B2 - Domestic hot water probe (NTC) (optional)
- B3 - Low temperature (NTC) probe (optional)
- B4 - External probe (NTC) (optional)
- H1 - Indicator light "ERROR" (230 Vac) (optional)
- H2 - Indicator light "Burner on" (230 Vac) (optional)
- M10-2 - Zone 2 circulator pump (optional)
- M30 - 3-way valve (optional)
- M31-2 - Zone 2 mixing valve (Optional)
- S20-2 - Zone 2 room thermostat (optional)
- 1 - 230 Vac - 50 Hz
- 2 - External relay (optional) - Coil 230 Vac Max. 0.1 A
- 3 - Domestic hot water
- 4 - Central heating
- 5 - Close
- 6 - Open
- 7 - Common

INSTALLER

USER

MAINTENANCE TECHNICIAN

TECHNICAL DATA



1.20 WIRING DIAGRAM - TWO DIRECT HEATING ZONES - 3-WAY VALVE - HYDRAULIC MANIFOLD (ONE APPLIANCE)



Direct zones could be in low temperature (set the heating sets of the two zones appropriately)



Further notes on this diagram can be found in parag. 1.15.
As a hydraulic diagram, please refer to fig. 16.

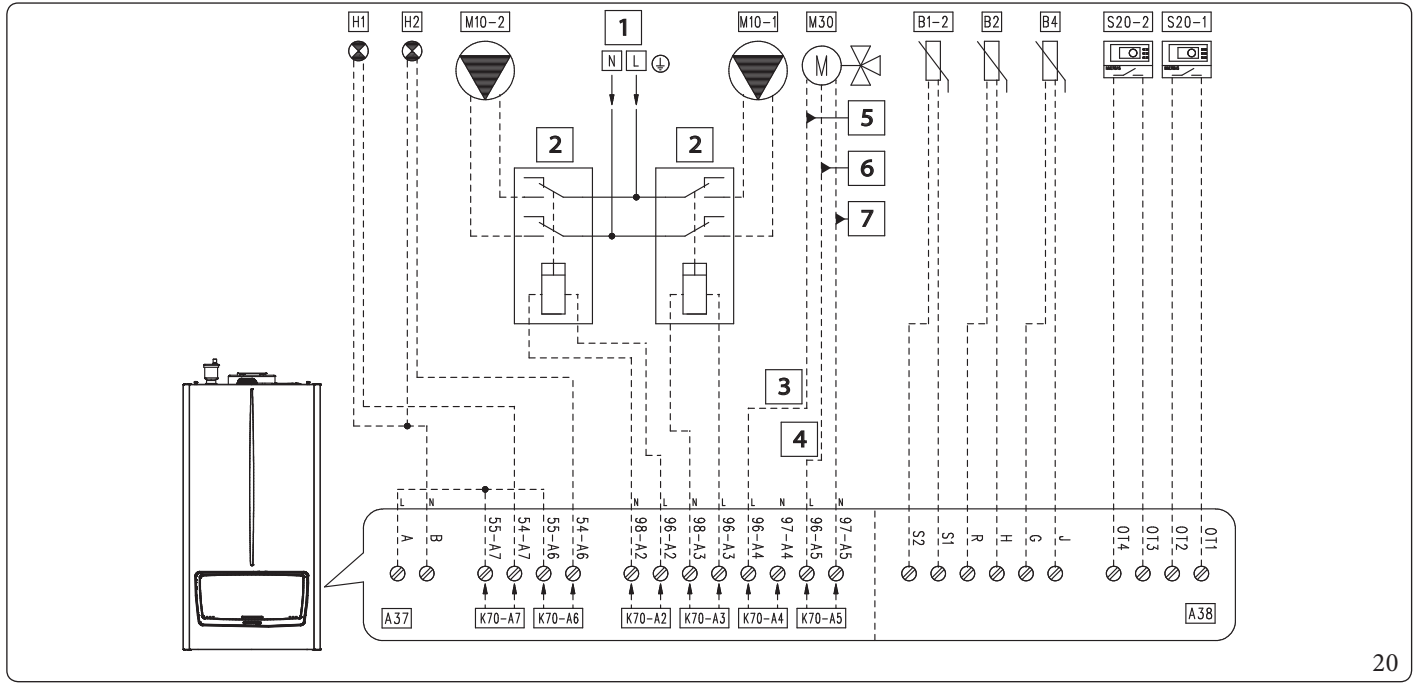

20



This diagram shows the use of the climate curve in the appliance.

Parameter configuration table "HYDRAULIC SETTINGS" (Technician menu)	
Parameter/menu name	Setting
Submenu "Relay settings":	
- K70-A1	- Relay not used
- K70-A2	- Zone 2 pump
- K70-A3	- Zone 1 pump
- K70-A4	- 3-way valve DHW
- K70-A5	- 3-way valve CH
- K70-A6	- Burner on
- K70-A7	- System fault
- System pump configuration	- not used
- System sensor	- CH mode
- CH Request type	- Room thermostat OTC
- DHW request type	- Sensor
- Parallel mode	- Disabled
Submenu "3-way valve":	
- 3-way valve selection	- Motorized
- Travel time	- 12
- Default position	- CH

Key (Fig. 20):

- A37 - Connection sheet (loads)
- A38 - Connection card (signals)
- B1-2 - System flow sensor (NTC) (optional)
- B2 - Domestic hot water probe (NTC) (optional)
- B4 - External probe (NTC) (optional)
- H1 - Indicator light "ERROR" (230 Vac) (optional)
- H2 - Indicator light "Burner on" (230 Vac) (optional)
- M10-1 - Zone 1 circulator pump (optional)
- M10-2 - Zone 2 circulator pump (optional)
- M30 - 3-way valve (optional)
- S20-1 - Zone 1 room thermostat (optional)
- S20-2 - Zone 2 room thermostat (optional)
- 1 - 230 Vac - 50 Hz
- 2 - External relay (optional) - Coil 230 Vac Max. 0.1 A
- 3 - Domestic hot water
- 4 - Central heating
- 5 - Close
- 6 - Open
- 7 - Common



1.21 WIRING DIAGRAM - ZONE 1 DIRECT HEATING- 3-WAY VALVE - HYDRAULIC MANIFOLD (ONE APPLIANCE)



Further notes on this diagram can be found in parag. 1.15.
As a hydraulic diagram, please refer to fig. 16.

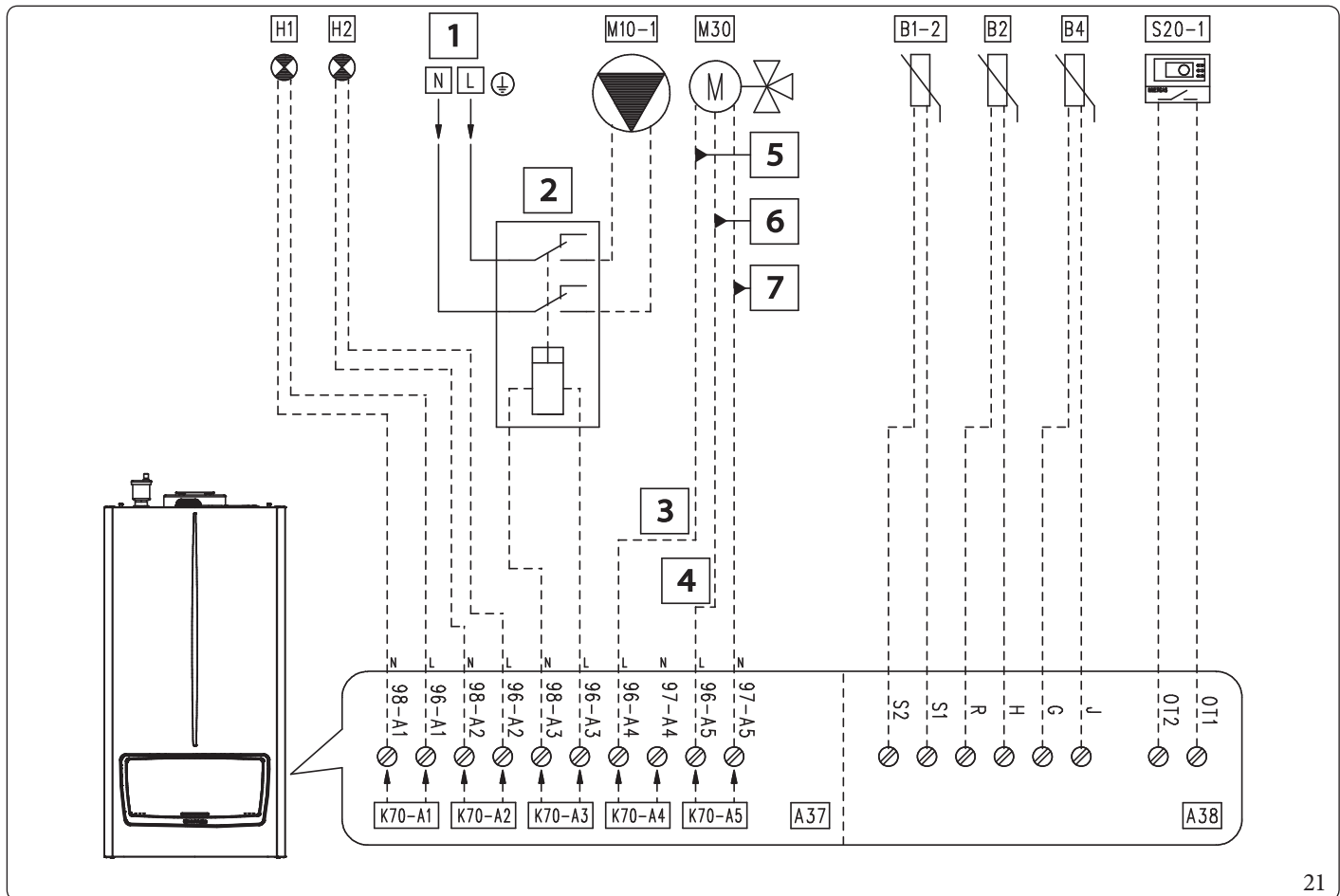

21

Parameter configuration table "HYDRAULIC SETTINGS" (Technician menu)	
Parameter/menu name	Setting
Submenu "Relay settings":	
- K70-A1	- System fault
- K70-A2	- Burner on
- K70-A3	Zone 1 pump
- K70-A4	- 3-way valve DHW
- K70-A5	- 3-way valve CH
- K70-A6	- Relay not used
- K70-A7	- Relay not used
- System pump configuration	- not used
Submenu "3-way valve":	
- 3-way valve selection	- Motorized
- Travel time	- 12
- Default position	- CH

Key (Fig. 21):

- A37 - Connection sheet (loads)
- A38 - Connection card (signals)
- B1-2 - System flow sensor (NTC) (optional)
- B2 - Domestic hot water probe (NTC) (optional)
- B4 - External probe (NTC) (optional)
- H1 - Indicator light "ERROR" (230 Vac) (optional)
- H2 - Indicator light "Burner on" (230 Vac) (optional)
- M10-1 - Zone 1 circulator pump (optional)
- M30 - 3-way valve (optional)
- S20-1 - Zone 1 room thermostat (optional)
- 1 - 230 Vac - 50 Hz
- 2 - External relay (optional) - Coil 230 Vac Max. 0.1 A
- 3 - Domestic hot water
- 4 - Central heating
- 5 - Close
- 6 - Open
- 7 - Common

INSTALLER

USER

MAINTENANCE TECHNICIAN

TECHNICAL DATA



1.22 WIRING DIAGRAM - DIRECT HEATING ZONE (WITHOUT HYDRAULIC MANIFOLD) - 3-WAY VALVE - DOMESTIC HOT WATER THERMOSTAT (ONE APPLIANCE)

i Further notes on this diagram can be found in parag. 1.15.
As a hydraulic diagram, please refer to fig. 16.

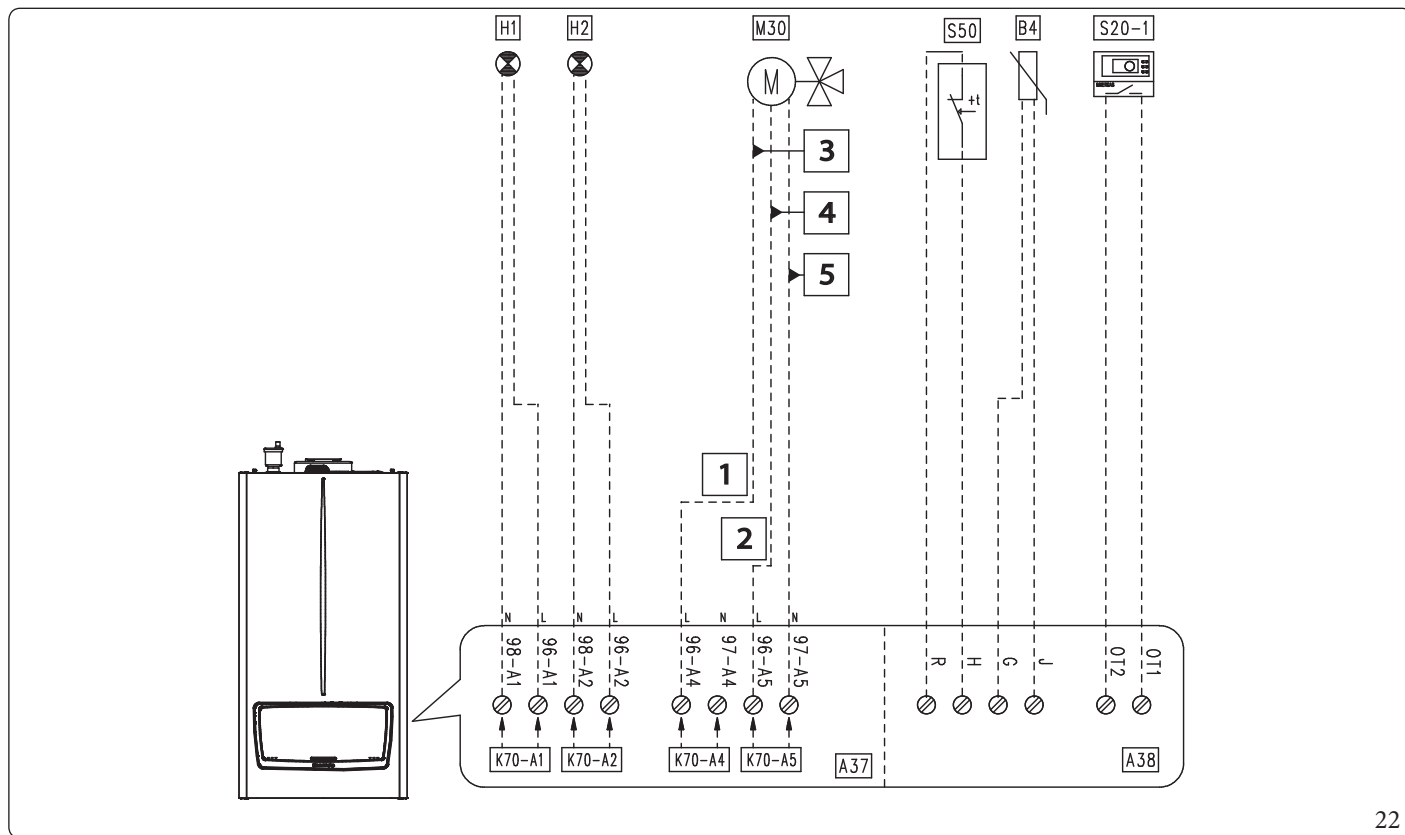

22

i This diagram shows the use of the DHW thermostat.

Parameter configuration table "HYDRAULICSETTINGS" (Technician menu)	
Parameter/menu name	Setting
Submenu "Relay settings":	
- K70-A1	- System fault
- K70-A2	- Burner on
- K70-A3	- Relay not used
- K70-A4	- 3-way valve DHW
- K70-A5	- 3-way valve CH
- K70-A6	- Relay not used
- K70-A7	- Relay not used
- System pump configuration	- not used
- System sensor	- Not used
- CH Request type	- Room thermostat OTC
- DHW request type	- Thermostat
- Parallel mode	- Disabled
Submenu "3-way valve":	
- 3-way valve selection	- Motorized
- Traveltime	- 12
- Default position	- CH

Key (Fig. 22):

- A37 - Connection sheet (loads)
- A38 - Connection card (signals)
- B4 - External probe (NTC) (optional)
- H1 - Indicator light "ERROR" (230 Vac) (optional)
- H2 - Indicator light "Burner on" (230 Vac) (optional)
- M30 - 3-way valve (optional)
- S20-1 - Zone 1 room thermostat (optional)
- S50 - DHW Thermostat/Contact
- 1 - Domestic hot water
- 2 - Central heating
- 3 - Close
- 4 - Open
- 5 - Common

1.23 WIRING DIAGRAM - TWO HYDRAULIC ZONES WITH SYSTEM HEATING PUMP - 3-WAY VALVE- HYDRAULIC MANIFOLD (ONE APPLIANCE)



Single upright column and two zones controlled by thermostats.



Further notes on this diagram can be found in parag. 1.15.
As a hydraulic diagram, please refer to fig. 16.

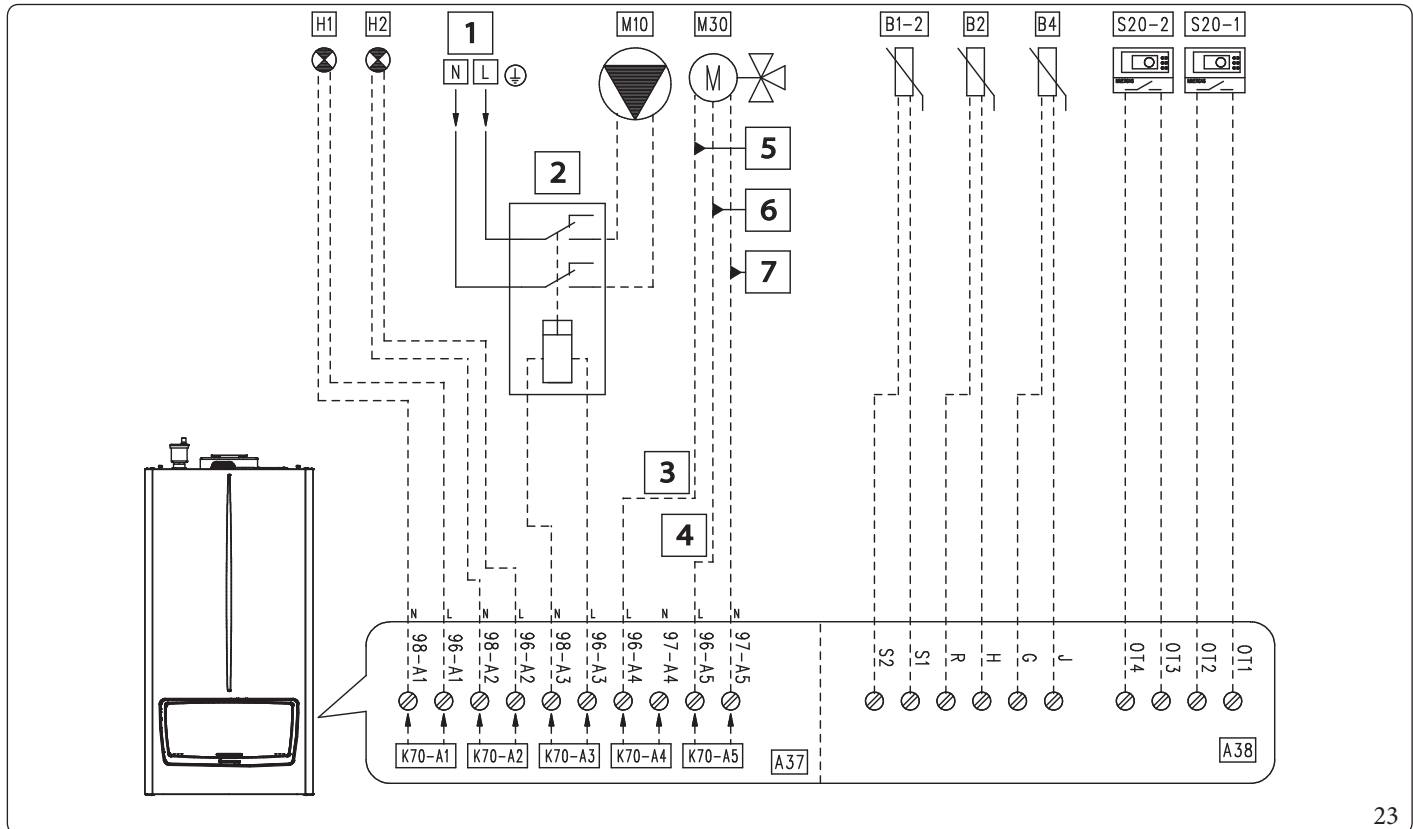

23

Parameter configuration table "HYDRAULICSETTINGS" (Technician menu)	
Parameter/menuname	Setting
Submenu "Relay settings":	
- K70-A1	- System fault
- K70-A2	- Burner on
- K70-A3	- System pump
- K70-A4	- 3-way valve DHW
- K70-A5	- 3-way valve CH
- K70-A6	- Relay not used
- K70-A7	- Relay not used
- System pump configuration	- Zone 1 + Zone 2
- System sensor	- CH mode
- CH Request type	- Room thermostat OTC
- DHW request type	- Sensor
- Parallel mode	- Disabled
Submenu "3-way valve":	
- 3-way valve selection	- Motorized
- Travel time	- 12
- Default position	- CH

Key (Fig. 23):

- A37 - Connection sheet (loads)
- A38 - Connection card (signals)
- B2 - Domestic hot water probe (NTC) (optional)
- B4 - External probe (NTC) (optional)
- H1 - Indicator light "ERROR" (230 Vac) (optional)
- H2 - Indicator light "Burner on" (230 Vac) (optional)
- M10 - Zone pump (optional)
- M30 - 3-way valve (optional)
- S20-1 - Zone 1 room thermostat (optional)
- S20-2 - Zone 2 room thermostat (optional)
- 1 - 230 Vac - 50 Hz
- 2 - External relay (optional) - Coil 230 Vac Max. 0.1 A
- 3 - Domestic hot water
- 4 - Central heating
- 5 - Close
- 6 - Open
- 7 - Common

INSTALLER

USER

MAINTENANCE TECHNICIAN

TECHNICAL DATA



1.24 WIRING DIAGRAM - TWO DIRECT HEATING ZONES - 3-WAY VALVE (WITHOUT HYDRAULIC MANIFOLD) (ONE APPLIANCE)



Further notes on this diagram can be found in parag. 1.15.
As a hydraulic diagram, please refer to fig. 16.

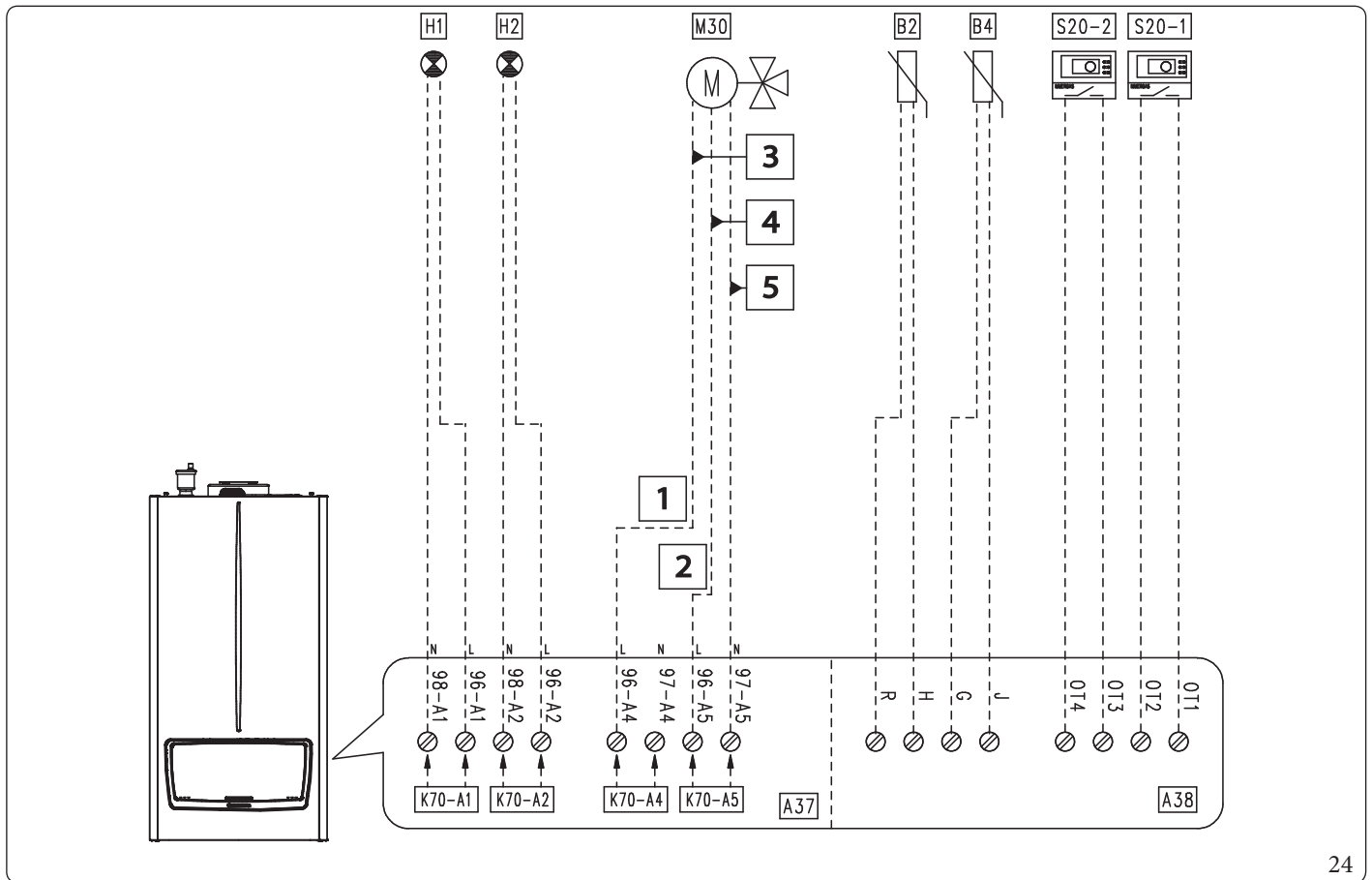

24

Parameter configuration table "HYDRAULIC SETTINGS" (Technician menu)	
Parameter/menu name	Setting
Submenu "Relay settings":	
- K70-A1	- System fault
- K70-A2	- Burner on
- K70-A3	- Relay not used
- K70-A4	- 3-way valve DHW
- K70-A5	- 3-way valve CH
- K70-A6	- Relay not used
- K70-A7	- Relay not used
- System pump configuration	- not used
Submenu "3-way valve":	
- 3-way valve selection	- Motorized
- Travel time	- 12
- Default position	- CH
Note: The room thermostat of zone 1 uses "Zone 1 CH setpoint"; the room thermostat of zone 2 uses "Zone 2 CH setpoint" (in the case of a demand from both thermostats, the device uses the higher setpoint).	

Key (Fig. 24):

- A37 - Connection sheet (loads)
- A38 - Connection card (signals)
- B2 - Domestic hot water probe (NTC) (optional)
- B4 - External probe (NTC) (optional)
- H1 - Indicator light "ERROR" (230 Vac) (optional)
- H2 - Indicator light "Burner on" (230 Vac) (optional)
- M30 - 3-way valve (optional)
- S20-1 - Zone 1 room thermostat (optional)
- S20-2 - Zone 2 room thermostat (optional)
- 1 - Domestic hot water
- 2 - Central heating
- 3 - Close
- 4 - Open
- 5 - Common



1.25 WIRING DIAGRAM - DIRECT HEATING ZONE WITH BOOSTER PUMP - 3-WAY VALVE WITH SPRING RETURN - EXTERNAL PROBE PRESENT (OFF) (ONE APPLIANCE)



Further notes on this diagram can be found in parag. 1.15.
As a hydraulic diagram, please refer to fig. 16.

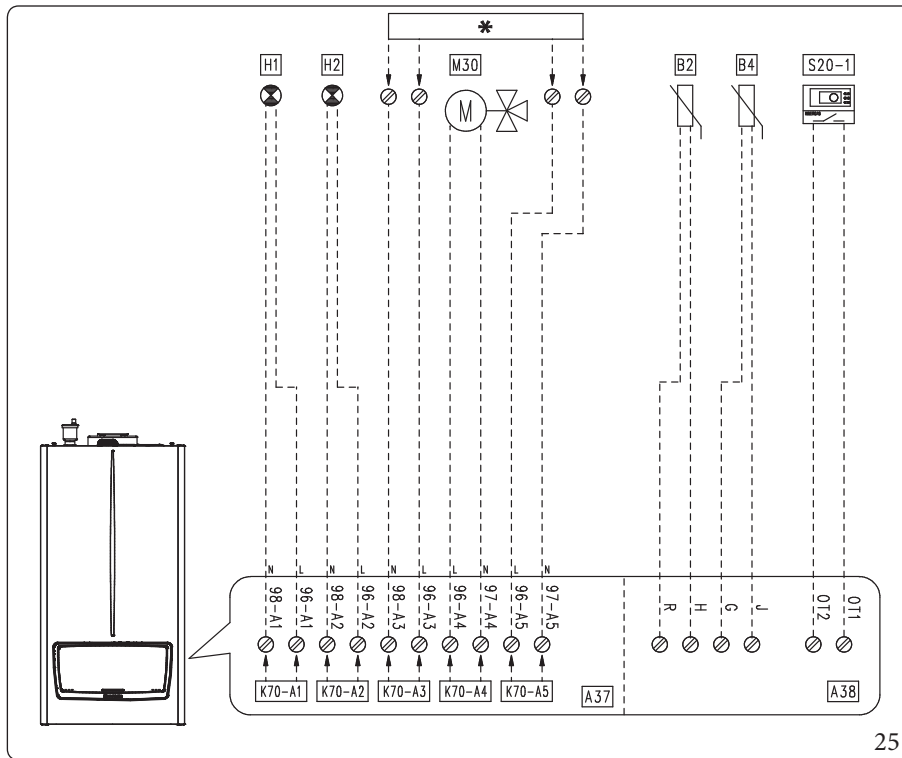

Key (Fig. 25):

- A37 - Connection sheet (loads)
- A38 - Connection card (signals)
- B2 - Domestic hot water probe (NTC) (optional)
- B4 - External probe (NTC) (optional)
- H1 - Indicator light "ERROR" (230 Vac) (optional)
- H2 - Indicator light "Burner on" (230 Vac) (optional)
- M30 - 3-way valve (optional)
- S20-1 - Zone 1 room thermostat (optional)
- * - See parameter configuration table



This diagram shows the use of the 3-way DHW valve with spring return, and the use of a booster pump (or live signal).

Parameter configuration table "HYDRAULICSETTINGS" (Technician menu)		
Parameter/menu name	Setting	Notes
Submenu "Relay settings":		
K70-A1	- Error	The relay "K70-A3" is activated together with the boiler circulator but not simultaneously. The relay "K70-A5" is always active. The relay "K70-A4" is only activated when "DHW Demand" is present. If the parameter "Default position" (3-way hydraulic valve) is set as "Domestic hot water", the relay "K70-A4" is always active and is deactivated in the event of a CH demand.
- K70-A2	- Burner on	
- K70-A3	- Booster pump	
- K70-A4	- 3-way valve DHW	
- K70-A5	- 3-way valve CH	
- K70-A6	- Relay not used	
- K70-A7	- Relay not used	
- System pump configuration	- not used	
- System sensor	- Not used	With the 'external sensor' and with the parameter "CH Request type" set as "Room thermostat setpoint", the flow temperature is not affected by the outside temperature (the temperature value measured by the external sensor is displayed as Information and available on the BUS).
- CH Request type	- Room thermostat setpoint	
- DHW request type	- Sensor	
- Parallel mode	- Disabled	
Submenu "3-way valve":		
- 3-way valve selection	- Spring return	The parameter "Travel time" has no effect if the parameter "3-way valve selection" is set as "Hydraulic".
- Travel time	- 12	
- Default position	- CH	



1.26 HYDRAULIC DIAGRAM - ONE DIRECT ZONE - ONE MIXED ZONE - DHW PUMP

INSTALLER

USER

MAINTENANCE TECHNICIAN

TECHNICAL DATA

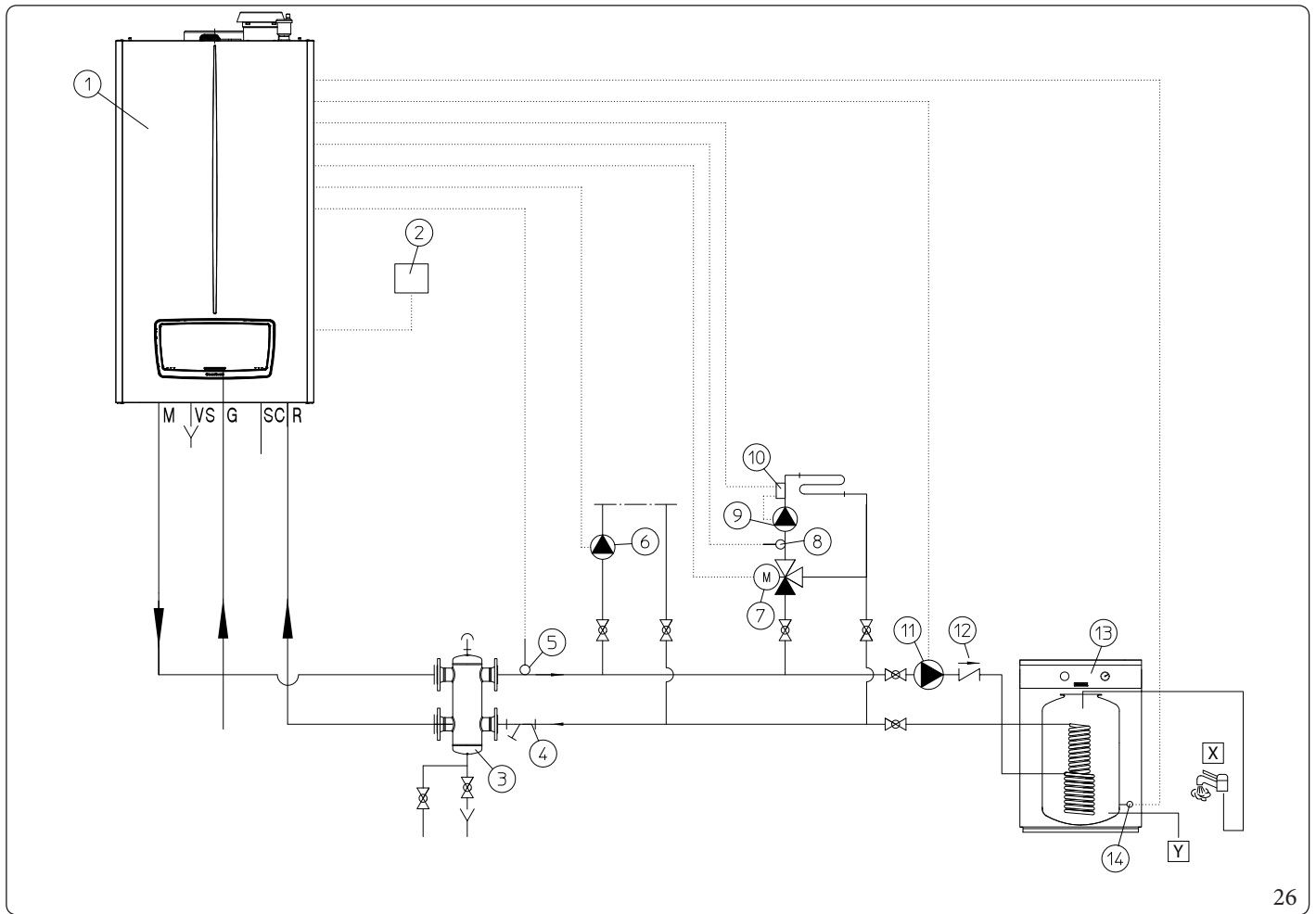

26

Key (Fig. 26):

- 1 - Generator
- 2 - External probe
- 3 - Manifold/mixer
- 4 - Slurry collection system filter
- 5 - Common flow probe
- 6 - Direct circuit pump
- 7 - Mixing valve
- 8 - Pressure gauge

- 9 - Minimum pressure switch with manual reset
- 10 - Safety thermostat
- 11 - Storage tank unit feeding pump
- 12 - Non return valve
- 13 - External storage tank unit
- 14 - Storage tank unit temperature probe
- X - Hot water
- Y - Cold water



1.27 WIRING DIAGRAM - ONE DIRECT ZONE - ONE MIXED ZONE - DHW PUMP - HYDRAULIC MANIFOLD (ONE APPLIANCE)



Further notes on this diagram can be found in parag. 1.15.
As a hydraulic diagram, please refer to fig. 26.

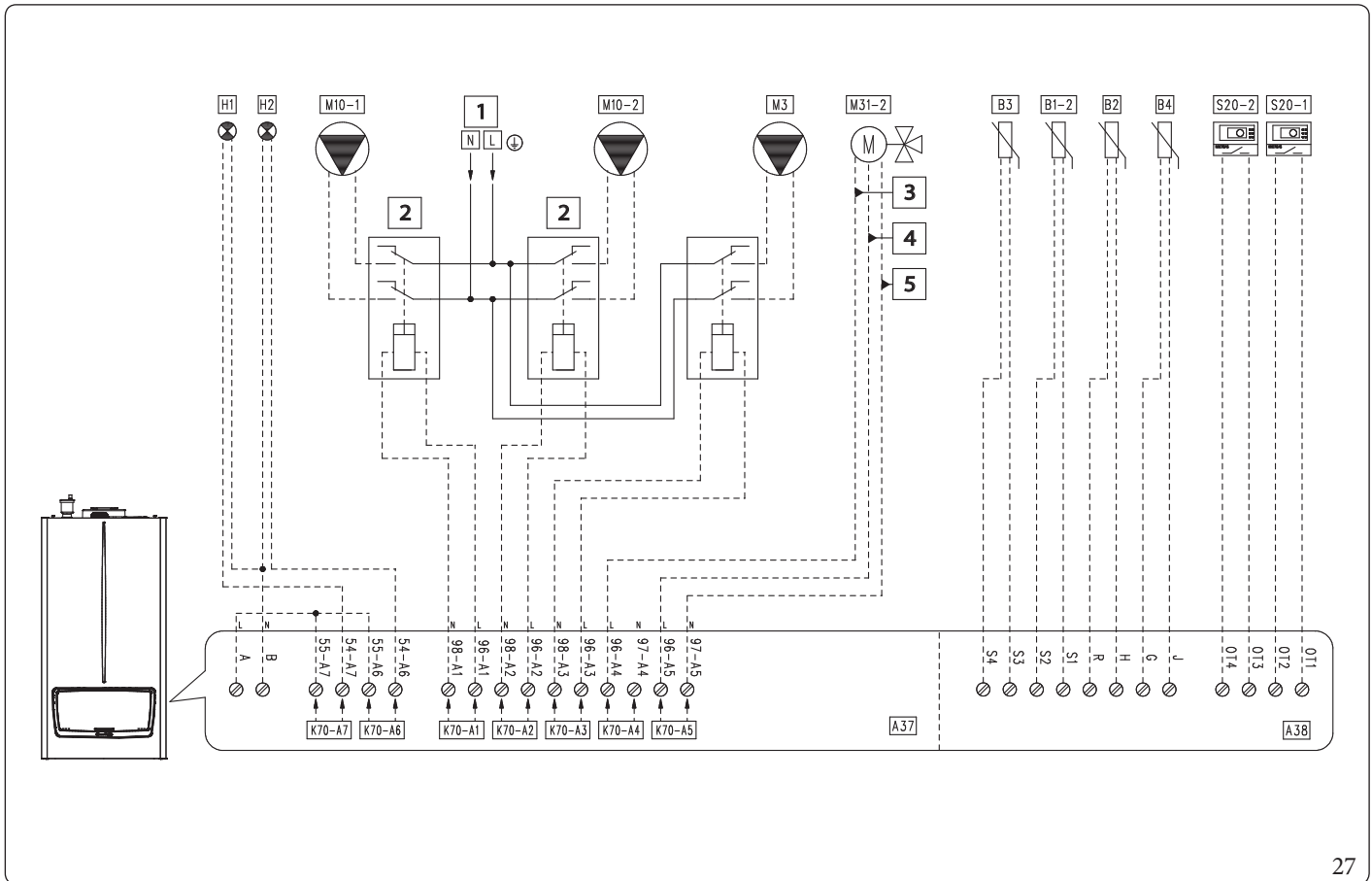

27

Parameter configuration table "HYDRAULIC SETTINGS" (Technician menu)	
Parameter/menu name	Setting
Submenu "Relay settings":	
- K70-A1	- Zone 1 pump
- K70-A2	- Zone 2 pump
- K70-A3	- DHW pump
- K70-A4	- Mixing valve: closes
- K70-A5	- Mixing valve: opens
- K70-A6	- Burner on
- K70-A7	- System fault
- System pump configuration	- not used
- System sensor	- CH + DHW mode
Submenu "Mix zone":	
- Mix zone selection	- 2
- Valve travel time	- 150
- CH Request type	- Room thermostat OTC
- DHW request type	- Sensor
- Parallel mode	- Disabled

Key (Fig. 27):

- A37 - Connection sheet (loads)
- A38 - Connection card (signals)
- B1-2 - System flow sensor (NTC) (optional)
- B2 - Domestic hot water probe (NTC) (optional)
- B3 - Low temperature (NTC) probe (optional)
- B4 - External probe (NTC) (optional)
- H1 - Indicator light "ERROR" (230 Vac) (optional)
- H2 - Indicator light "Burner on" (230 Vac) (optional)
- M3 - DHW pump (optional)
- M10-1 - Zone 1 circulator pump (optional)
- M10-2 - Zone 2 circulator pump (optional)
- M31-2 - Zone 2 mixing valve (Optional)
- S20-1 - Zone 1 room thermostat (optional)
- S20-2 - Zone 2 room thermostat (optional)
- 1 - 230 Vac - 50 Hz
- 2 - External relay (optional) - Coil 230 Vac Max. 0.1 A
- 3 - Close
- 4 - Open
- 5 - Common

INSTALLER

USER

MAINTENANCE TECHNICIAN

TECHNICAL DATA



1.28 WIRING DIAGRAM - ZONE 1 MIXED - DHW PUMP - HYDRAULIC MANIFOLD (ONE APPLIANCE)



Further notes on this diagram can be found in parag. 1.15.
As a hydraulic diagram, please refer to fig. 26.

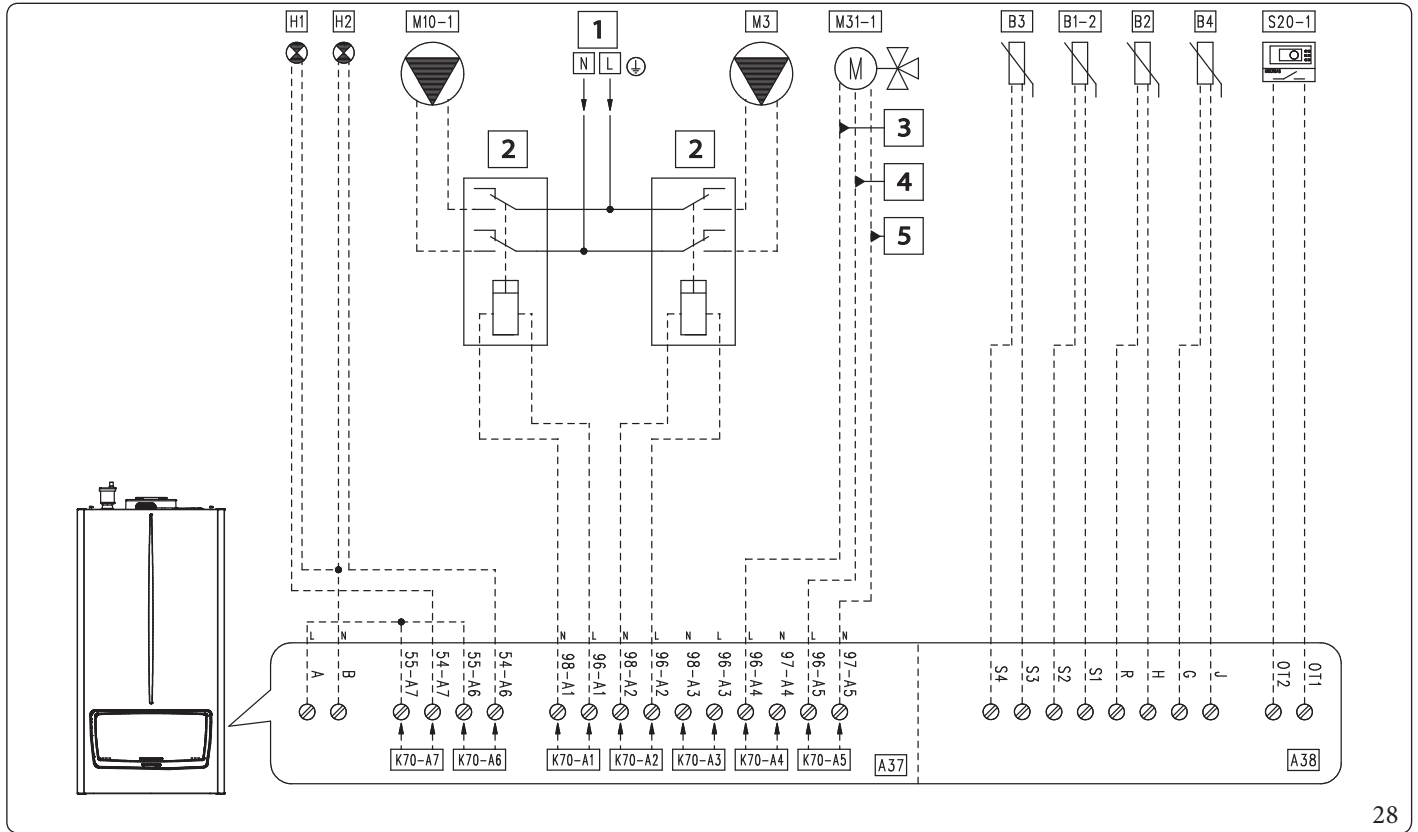

This diagram shows the mixed zone configuration for zone 1.

Parameter configuration table "HYDRAULIC SETTINGS" (Technician menu)	
Parameter/menu name	Setting
Submenu "Relay settings":	
- K70-A1	- Zone 1 pump
- K70-A2	- DHW pump
- K70-A3	- Relay not used
- K70-A4	- Mixing valve: closes
- K70-A5	- Mixing valve: opens
- K70-A6	- Burner on
- K70-A7	- System fault
- System pump configuration	- not used
- System sensor	- CH+DHW mode
Submenu "Mix zone":	
- Mix zone selection	- 1
- Valve travel time	- 150
- CH Request type	- Room thermostat OTC
- DHW request type	- Sensor
- Parallel mode	- Disabled

Key (Fig. 28):

- A37 - Connection sheet (loads)
- A38 - Connection card (signals)
- B1-2 - System flow sensor (NTC) (optional)
- B2 - Domestic hot water probe (NTC) (optional)
- B3 - Low temperature (NTC) probe (optional)
- B4 - External probe (NTC) (optional)
- H1 - Indicator light "ERROR" (230 Vac) (optional)
- H2 - Indicator light "Burner on" (230 Vac) (optional)
- M3 - DHW pump (optional)
- M10-1 - Zone 1 circulator pump (optional)
- M31-1 - Mixing valve - zone 1 (optional)
- S20-1 - Zone 1 room thermostat (optional)
- 1 - 230 Vac - 50 Hz
- 2 - External relay (optional) - Coil 230 Vac Max. 0.1 A
- 3 - Close
- 4 - Open
- 5 - Common



1.29 WIRING DIAGRAM - TWO DIRECT HEATING ZONES - DHW PUMP - OPENTHERM THERMOSTATS - HYDRAULIC MANIFOLD (ONE APPLIANCE)



Further notes on this diagram can be found in parag. 1.15.
As a hydraulic diagram, please refer to fig. 26.

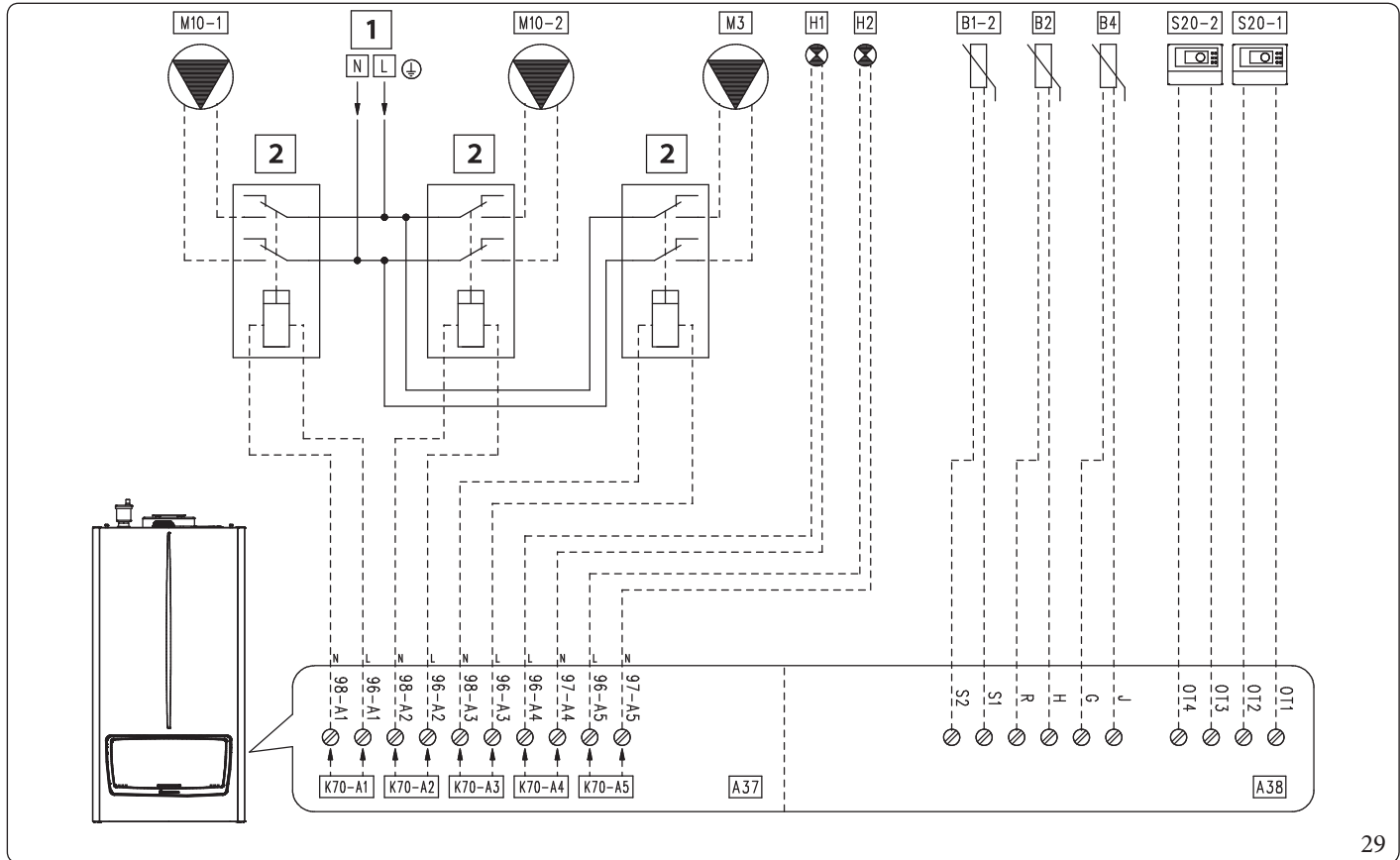

29



This diagram shows that for the use of OpenTherm thermostats, the parameter "CH Request type" must be set as "Room thermostat setpoint".

Parameter configuration table "HYDRAULICSETTINGS" (Technician menu)	
Parameter/menu name	Setting
Submenu "Relay settings":	
- K70-A1	- Zone 1 pump
- K70-A2	- Zone 2 pump
- K70-A3	- DHW pump
- K70-A4	- System fault
- K70-A5	- Burner on
- K70-A6	- Relay not used
- K70-A7	- Relay not used
- System pump configuration	- not used
- System sensor	- CH + DHW mode
- CH Request type	- Room thermostat setpoint
- DHW request type	- Sensor
- Parallel mode	- Disabled

Key (Fig. 29):

- A37 - Connection sheet (loads)
- A38 - Connection card (signals)
- B1-2 - System flow sensor (NTC) (optional)
- B2 - Domestic hot water probe (NTC) (optional)
- B4 - External probe (NTC) (optional)
- H1 - Indicator light "ERROR" (230 Vac) (optional)
- H2 - Indicator light "Burner on" (230 Vac) (optional)
- M3 - DHW pump (optional)
- M10-1 - Zone 1 circulator pump (optional)
- M10-2 - Zone 2 circulator pump (optional)
- S20-1 - Zone 1 room thermostat (optional)
- S20-2 - Zone 2 room thermostat (optional)
- 1 - 230 Vac - 50 Hz
- 2 - External relay (optional) - Coil 230 Vac Max. 0.1 A
- 3 - Close
- 4 - Open
- 5 - Common

INSTALLER

USER

MAINTENANCE TECHNICIAN

TECHNICAL DATA



1.30 WIRING DIAGRAM - ZONE 1 DIRECT - DHW PUMP - HYDRAULIC MANIFOLD (ONE APPLIANCE)



Further notes on this diagram can be found in parag. 1.15.
As a hydraulic diagram, please refer to fig. 26.

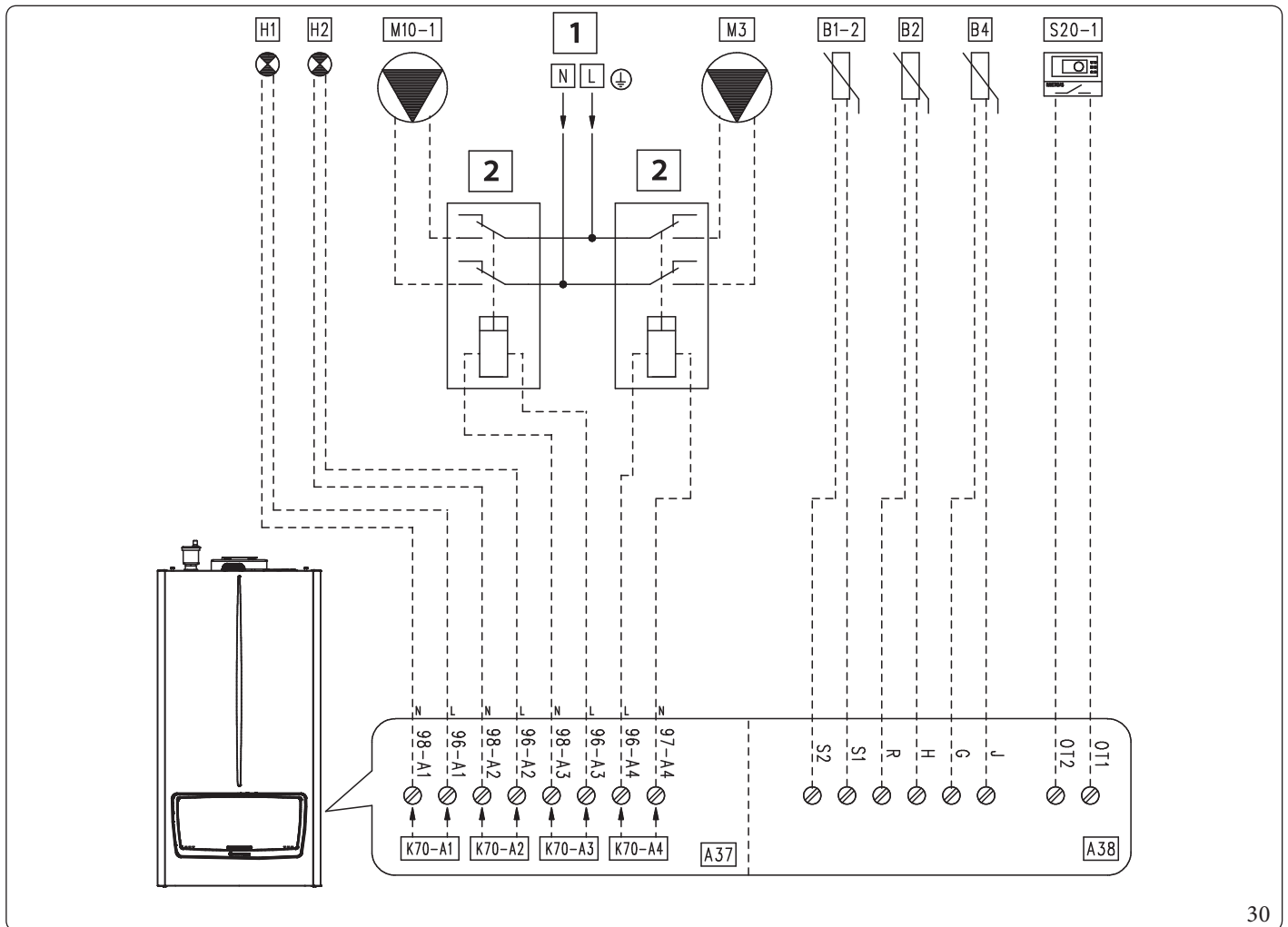

30

Parameter configuration table "HYDRAULIC SETTINGS" (Technician menu)	
Parameter/menu name	Setting
Submenu "Relay settings":	
- K70-A1	- System fault
- K70-A2	- Burner on
- K70-A3	- Zone 1 pump
- K70-A4	- DHW pump
- K70-A5	- Relay not used
- K70-A6	- Relay not used
- K70-A7	- Relay not used
- System pump configuration	- not used
- System sensor	- CH + DHW mode
- CH Request type	- Room thermostat OTC
- DHW request type	- Sensor
- Parallel mode	- Disabled

Key (Fig. 30):

- A37 - Connection sheet (loads)
- A38 - Connection card (signals)
- B1-2 - System flow sensor (NTC) (optional)
- B2 - Domestic hot water probe (NTC) (optional)
- B4 - External probe (NTC) (optional)
- H1 - Indicator light "ERROR" (230 Vac) (optional)
- H2 - Indicator light "Burner on" (230 Vac) (optional)
- M3 - DHW pump (optional)
- M10-1 - Zone 1 circulator pump (optional)
- S20-1 - Zone 1 room thermostat (optional)
- 1 - 230 Vac - 50 Hz
- 2 - External relay (optional) - Coil 230 Vac Max. 0.1 A



1.31 WIRING DIAGRAM - ZONE 1 DIRECT - DHW PUMP - PARALLEL OPERATION - HYDRAULIC MANIFOLD (ONE APPLIANCE)



Further notes on this diagram can be found in parag. 1.15.
As a hydraulic diagram, please refer to fig. 26.

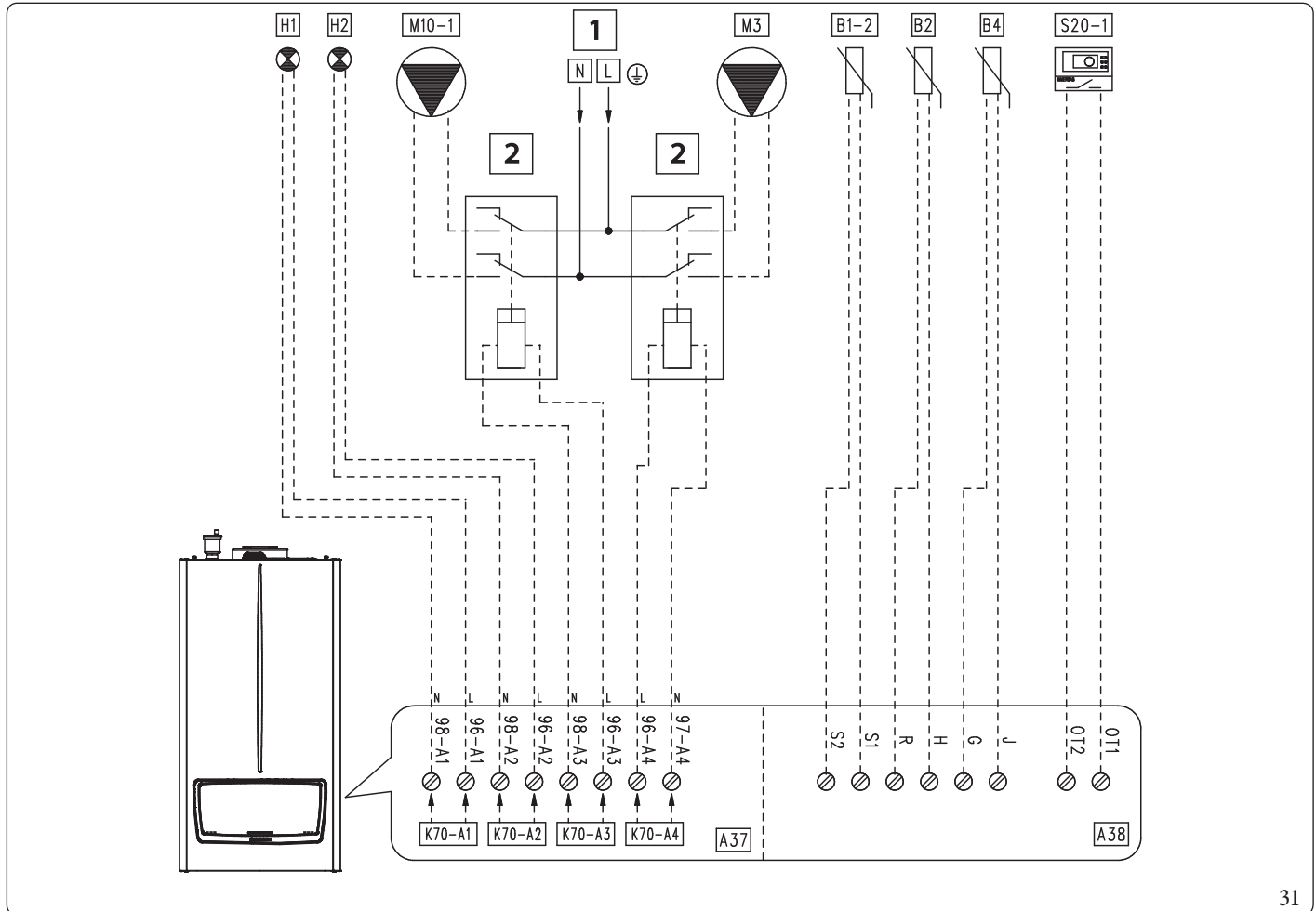

31

Parameter configuration table "HYDRAULICSETTINGS" (Technician menu)	
Parameter/menu name	Setting
Submenu "Relay settings":	
- K70-A1	- System fault
- K70-A2	- Burner on
- K70-A3	- Zone 1 pump
- K70-A4	- DHW pump
- K70-A5	- Relay not used
- K70-A6	- Relay not used
- K70-A7	- Relay not used
- System pump configuration	- not used
- System sensor	- CH + DHW mode
- CH Request type	- Room thermostat OTC
- DHW request type	- Sensor
- Parallel mode	- Enabled
With parallel mode enabled, the boiler uses the DHW setpoint and the maximum power used is the greater of the DHW and CH setpoint.	

Key (Fig. 31):

- A37 - Connection sheet (loads)
- A38 - Connection card (signals)
- B1-2 - System flow sensor (NTC) (optional)
- B2 - Domestic hot water probe (NTC) (optional)
- B4 - External probe (NTC) (optional)
- H1 - Indicator light "ERROR" (230 Vac) (optional)
- H2 - Indicator light "Burner on" (230 Vac) (optional)
- M3 - DHW pump (optional)
- M10-1 - Zone 1 circulator pump (optional)
- S20-1 - Zone 1 room thermostat (optional)
- 1 - 230 Vac - 50 Hz
- 2 - External relay (optional) - Coil 230 Vac Max. 0.1 A

INSTALLER

USER

MAINTENANCE TECHNICIAN

TECHNICAL DATA



1.32 WIRING DIAGRAM - TWO DIRECT HEATING ZONES - DHW PUMP - CH REQUEST TYPE CONSTANT SETPOINT - HYDRAULIC MANIFOLD (ONE APPLIANCE)



Further notes on this diagram can be found in parag. 1.15.
As a hydraulic diagram, please refer to fig. 26.

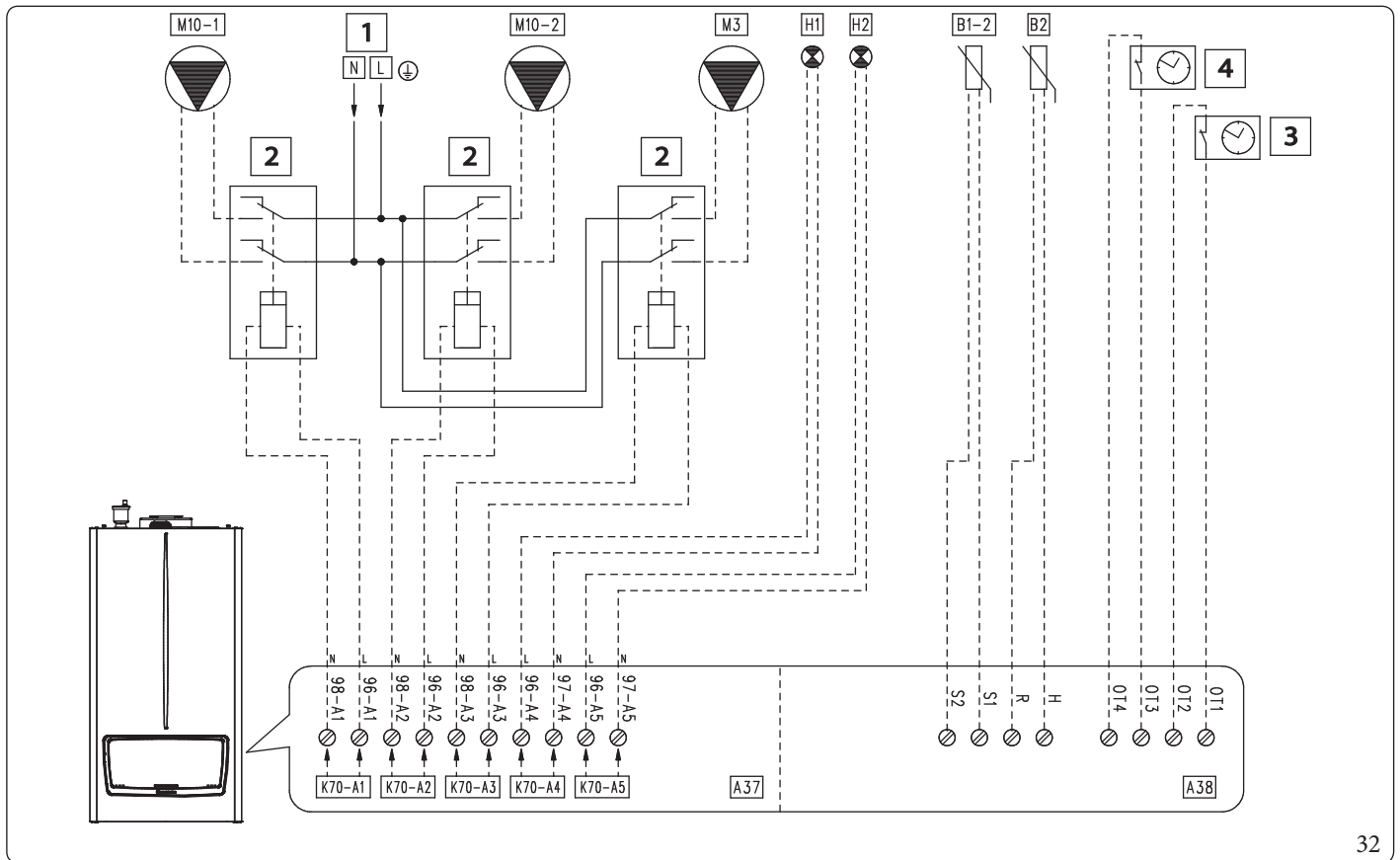

32



This diagram is a possible application with parameter "CH Request type" set as "Constant Setpoint".

Parameter configuration table	
"HYDRAULIC SETTINGS" (Technician menu)	
Parameter/menu name	Setting
Submenu "Relay settings":	
- K70-A1	- Zone 1 pump
- K70-A2	- Zone 2 pump
- K70-A3	- DHW pump
- K70-A4	- System fault
- K70-A5	- Burner on
- K70-A6	- Relay not used
- K70-A7	- Relay not used
- System pump configuration	- not used
- System sensor	- CH + DHW mode
- CH Request type	- Constant Setpoint
- DHW request type	- Sensor
- Parallel mode	- Disabled
Note: when the contact of the programming clock is opened, the CH setpoint is reduced according to the parameters "Zone 1 CH constant setpoint reduction" and "Zone 2 CH constant setpoint reduction" (by default these two parameters are 0°C).	

Key (Fig. 32):

- A37 - Connection sheet (loads)
- A38 - Connection card (signals)
- B1-2 - System flow sensor (NTC) (optional)
- B2 - Domestic hot water probe (NTC) (optional)
- H1 - Indicator light "ERROR" (230 Vac) (optional)
- H2 - Indicator light "Burner on" (230 Vac) (optional)
- M3 - DHW pump (optional)
- M10-1 - Zone 1 circulator pump (optional)
- M10-2 - Zone 2 circulator pump (optional)
- 1 - 230 Vac - 50 Hz
- 2 - External relay (optional) - Coil 230 Vac Max. 0.1 A
- 3 - Zone 1 programmer clock (optional)
- 4 - Zone 2 programming clock (optional)



1.33 WIRING DIAGRAM - TWO DIRECT HEATING ZONES - DHW PUMP - CH REQUEST TYPE ONLY OTC - HYDRAULIC MANIFOLD (ONE APPLIANCE)



Further notes on this diagram can be found in parag. 1.15.
As a hydraulic diagram, please refer to fig. 26.

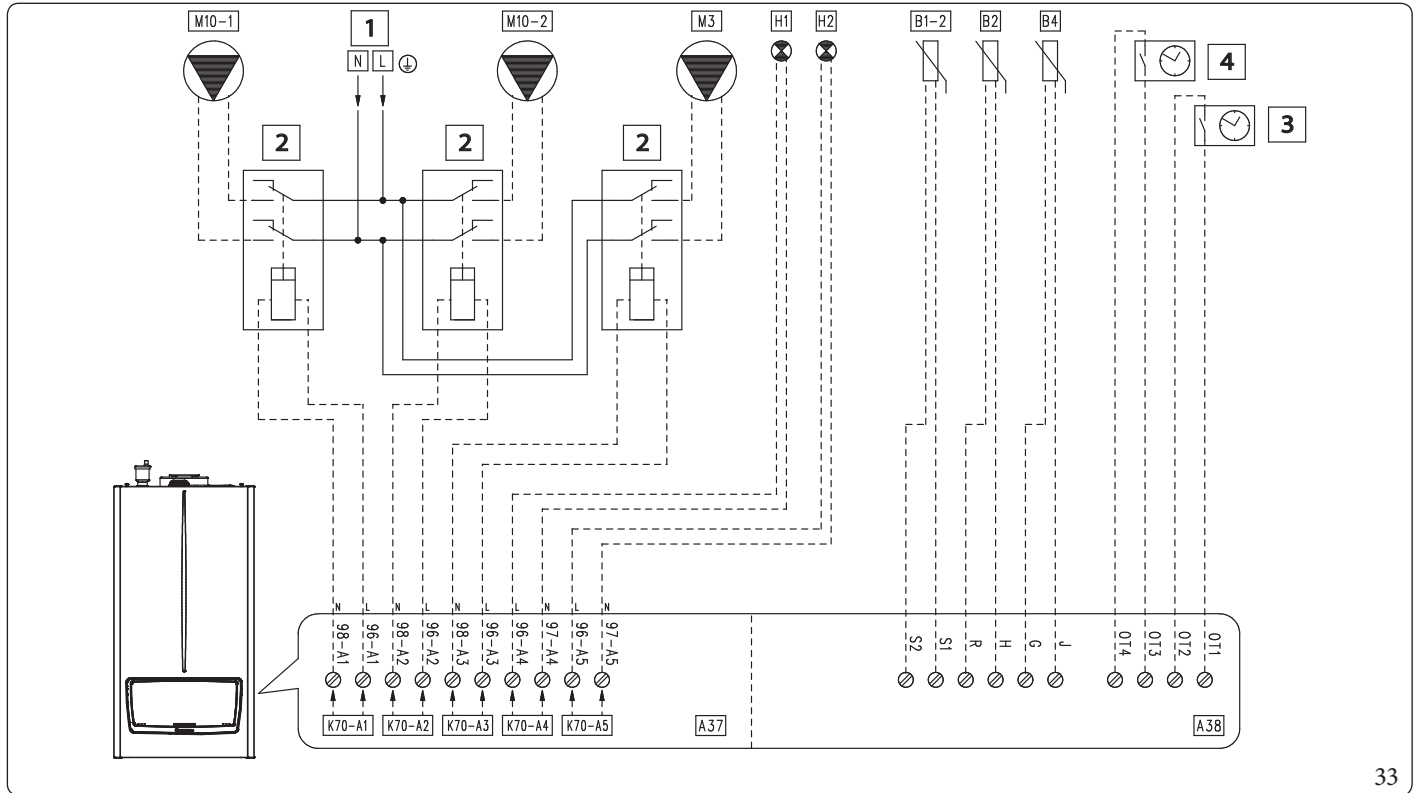

33



This diagram is a possible application with parameter "CH Request type" set as "Only OTC".

Parameter configuration table "HYDRAULIC SETTINGS" (Technician menu)	
Parameter/menu name	Setting
Submenu "Relay settings":	
- K70-A1	- Zone 1 pump
- K70-A2	- Zone 2 pump
- K70-A3	- DHW pump
- K70-A4	- System fault
- K70-A5	- Burner on
- K70-A6	- Relay not used
- K70-A7	- Relay not used
- System pump configuration	- not used
- System sensor	- CH + DHW mode
- CH Request type	- Only OTC
- DHW request type	- Sensor
- Parallel mode	- Disabled
Note: When the contact of the programming clock is closed, the CH setpoint is reduced according to the parameters "Zone 1 CHECO setpoint reduction" and "Zone 2 CHECO setpoint reduction". As an alternative to the programming clock, use the schedule.	

Key (Fig. 33):

- A37 - Connection sheet (loads)
- A38 - Connection card (signals)
- B1-2 - System flow sensor (NTC) (optional)
- B2 - Domestic hot water probe (NTC) (optional)
- B4 - External probe (NTC) (optional)
- H1 - Indicator light "ERROR" (230 Vac) (optional)
- H2 - Indicator light "Burner on" (230 Vac) (optional)
- M3 - DHW pump (optional)
- M10-1 - Zone 1 circulator pump (optional)
- M10-2 - Zone 2 circulator pump (optional)
- 1 - 230 Vac - 50 Hz
- 2 - External relay (optional) - Coil 230 Vac Max. 0.1 A
- 3 - Zone 1 programmer clock (optional)
- 4 - Zone 2 programming clock (optional)

INSTALLER

USER

MAINTENANCE TECHNICIAN

TECHNICAL DATA



1.34 WIRING DIAGRAM - DIRECT HEATING ZONE - BOOSTER PUMP - WITHOUT HYDRAULIC MANIFOLD (ONE APPLIANCE)



Further notes on this diagram can be found in parag. 1.15.
As a hydraulic diagram, please refer to fig. 26.

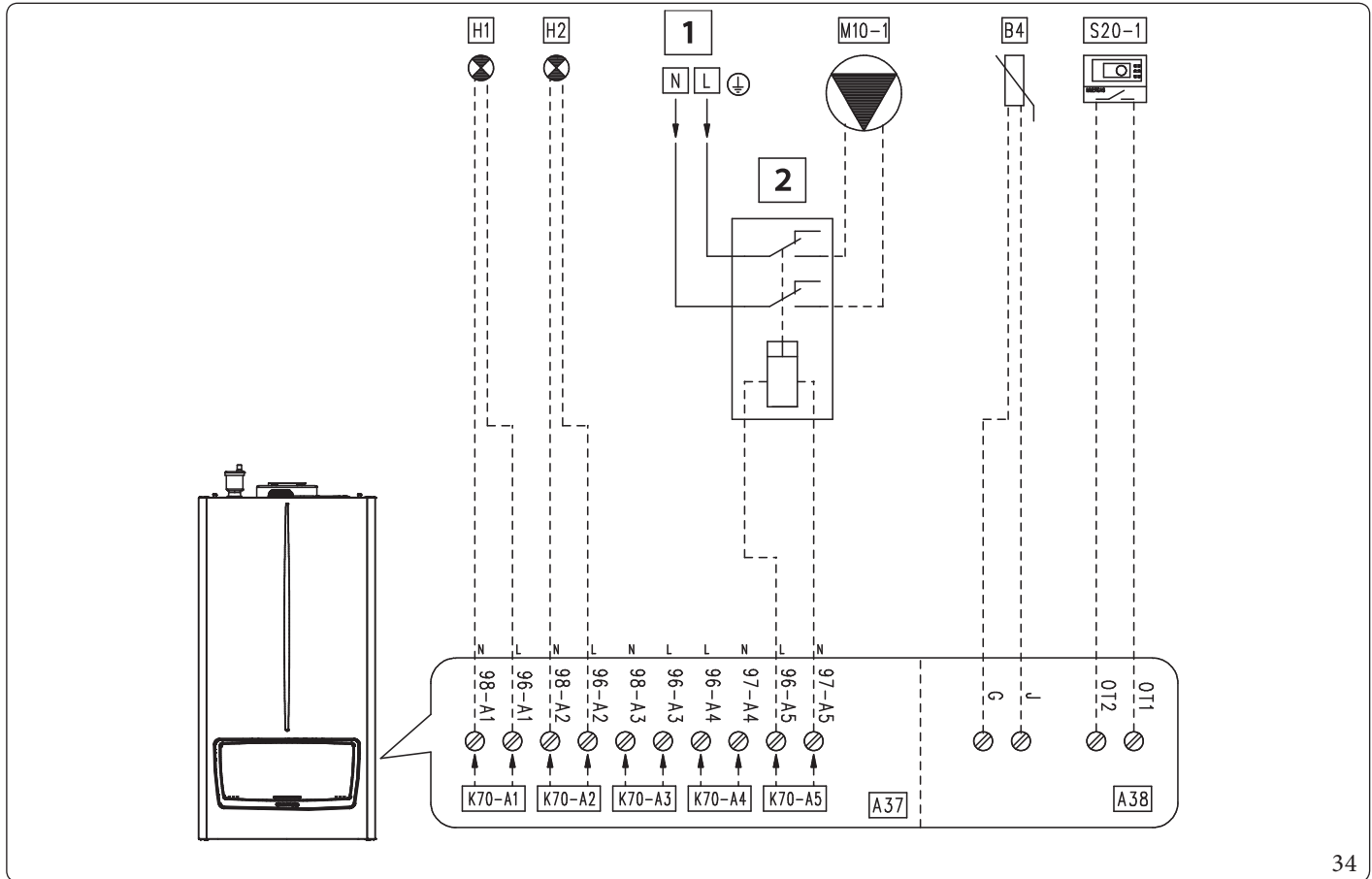

34

Parameter configuration table "HYDRAULICSETTINGS" (Technician menu)	
Parameter/menu name	Setting
Submenu "Relay settings":	
- K70-A1	- System fault
- K70-A2	- Burner on
- K70-A3	- Relay not used
- K70-A4	- Relay not used
- K70-A5	- Booster pump
- K70-A6	- Relay not used
- K70-A7	- Relay not used
- System pump configuration	- not used
- System sensor	- Not used
- CH Request type	- Room thermostat OTC
- DHW request type	- Sensor
- Parallel mode	- Disabled
Note: The booster pump (Booster pump) is activated together with the appliance's pump though not simultaneously.	

Key (Fig. 34):

- A37 - Connection sheet (loads)
- A38 - Connection card (signals)
- B4 - External probe (NTC) (optional)
- H1 - Indicator light "ERROR" (230 Vac) (optional)
- H2 - Indicator light "Burner on" (230 Vac) (optional)
- M10-1 - Zone 1 circulator pump (optional)
- S20-1 - Zone 1 room thermostat (optional)
- 1 - 230 Vac - 50 Hz
- 2 - External relay (optional) - Coil 230 Vac Max. 0.1 A



1.35 WIRING DIAGRAM WITH HIGH POWER REMOTE CONTROL

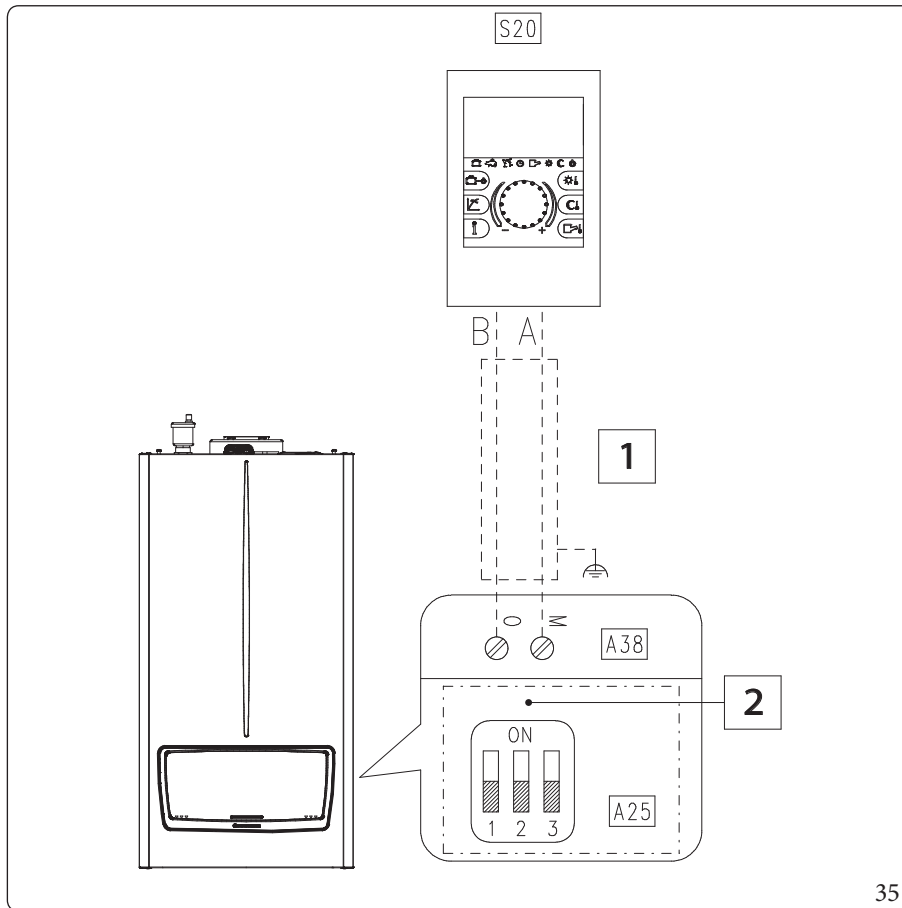

Key (Fig. 35):

- A25 - CLIP-IN (optional)
- A38 - Connection card (signals)
- S20 - Room thermostat (optional)
- 1 - Cable type: J-Y(St)Y 2x2x0,6.
Maximum permitted length: 50 m
- 2 - Address 0

INSTALLER

USER



Remove link X40



The parameter "CH Request type" must be set as "Room thermostat setpoint" (default value).

It is possible to connect the following sensors to the device and read them via BUS:

- External probe (B4)
- DHW probe (B2)
- DHW Thermostat/Contact (S50)



The DHW can be managed locally (appropriately configure the 3-way valve via the parameters in the "Relay settings" menu).

MAINTENANCE TECHNICIAN

TECHNICAL DATA



1.36 WIRING DIAGRAM CONNECTION TO BMS SYSTEM

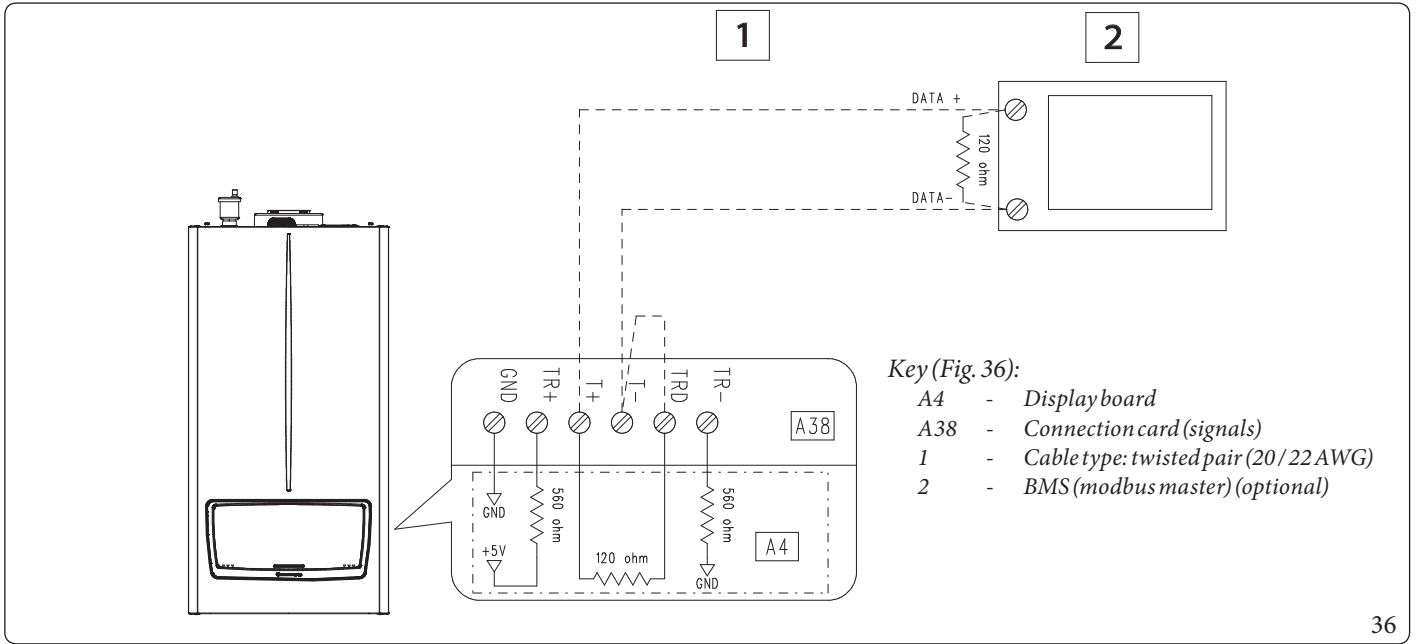

36



Remove link X40



The Modbus parameters can be found at "Technician menu / SYSTEM SETTINGS / Modbus parameters".



The parameter "CH Request type" must be set as "Room thermostat setpoint" (default value).

It is possible to connect the following sensors to the device and read them via BUS:

- System flow sensor (B1-2)
- External probe (B4)
- DHW probe (B2)
- DHW Thermostat/Contact (S50)



The DHW can be managed locally (appropriately configure the 3-way valve via the parameters in the "Relay settings" menu).



BMS

On one side of the bus, there must be a pull up resistance and a pull down resistance.

The diagram assumes that the two pull up and pull down resistances are already present in the external device (box 2 in the figure 36); if these resistances are not present on the external device, it is necessary to make the link between the TR+ terminals with T+ and TR- with T-, so as to use the pull up and pull down resistances already present on the display board (A4).

The termination resistance (120 ohm) is required on both sides of the BUS; to achieve this, the installer must fit the 120ohm resistance (not supplied) on the external device (box 2 in fig. 36) and then make the link between the TRD and T- terminals, so as to use the resistance already present on the display board (A4).



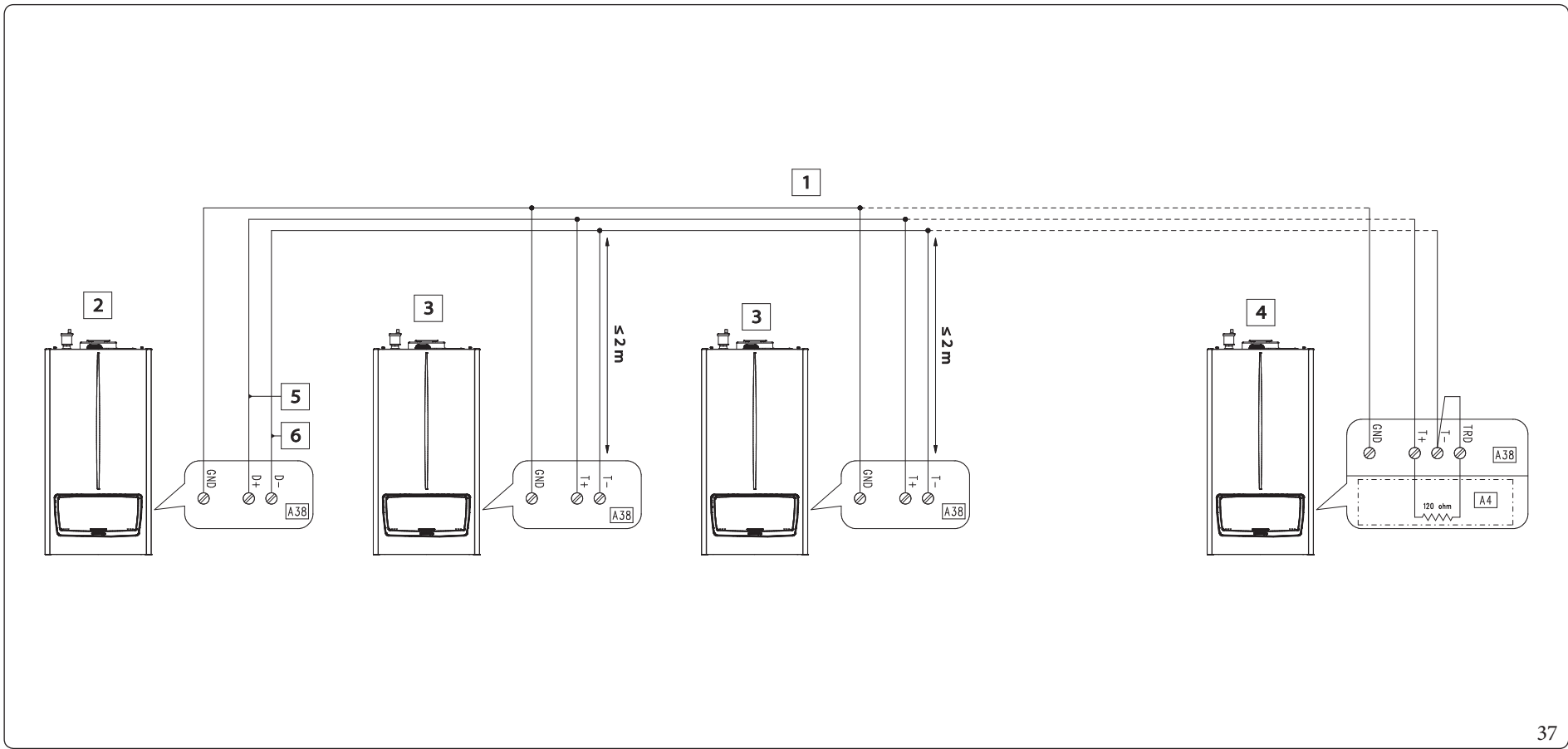

37

Key (Fig. 37):

- A4 - Displayboard
- A38 - Connection card (signals)
- 1 - Cable type: 2x twisted pair (20/22 AWG)*
- 2 - Master Boiler
- 3 - Boiler Slave
- 4 - Slave boiler (last)
- 5 - Data +
- 6 - Data -

The communication BUS between the devices of the simple cascade is via Modbus protocol (RS485).

The Modbus parameters, which can be configured via "MENU", have no effect on the simple cascade but serve for the BMS.



In one pair of the twisted pair, connect the 'Data +' and 'Data -' signals, and in the other pair, connect the 'GND'.



The link between the "TRD" and "T-" terminals is the responsibility of the installer (the 120ohm resistance is already present on the "Display board").



1.38 GENERALEXAMPLES OF TYPES OF INSTALLATION OF FLUE SYSTEMS



For the types of installation of the flue systems approved for this product, scrupulously follow what is indicated in the table in paragraph 4.3, in the “type of appliance” line.

INSTALLER

USER

MAINTENANCE TECHNICIAN

TECHNICAL DATA

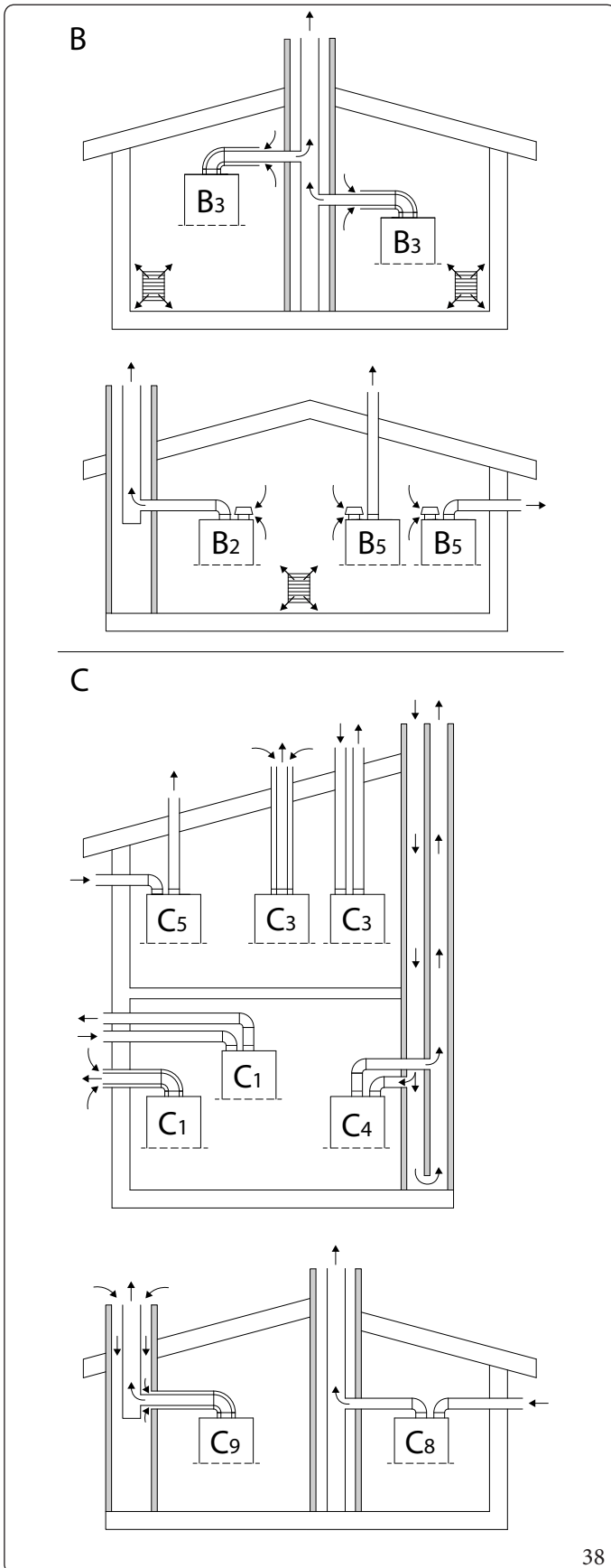

Installation types summarised table (Fig. 38):	
B	Appliance that withdraws air from the environment where it is installed and releases combustion products outside (either directly or through the flue).
B ₂	Appliance that withdraws air from the environment where it is installed and releases combustion products in the flue.
B ₃	Appliance connected to a conventional flue. A concentric pipe connects the flue to the appliance, in which the pressurised exhaust pipe is completely enveloped by combustion air withdrawn from inside the room. The combustion air is withdrawn by calibrated orifices present in the intake pipe.
B ₅	Appliance that withdraws air from the environment where it is installed and directly releases combustion products outside (through wall or roof).
C	Appliance whose combustion circuit (air feed, combustion chamber, heat exchanger and exhaust of combustion products) is sealed with respect to the room where the appliance is installed.
C ₁	Appliance with pipes connecting to a horizontal terminal, which simultaneously allows the inlet of combustion air and the release of flue gas through concentric orifices or close enough to be in similar wind conditions.
C ₃	Appliance with pipes connecting to a vertical terminal, which simultaneously allows the inlet of combustion air and the release of flue gas through concentric orifices or close enough to be in similar wind conditions.
C ₄	Appliance with two separate pipes connecting to a collective conventional flue. The flue consists of two pipes, concentric or separate, with air intake in one and flue gas release in the other and are in similar wind conditions.
C ₅	Appliance that withdraws air from outside and directly releases combustion products outside (through wall or roof). These pipes can end up in different pressure zones.
C ₆	Type C appliance intended to be connected to an approved system and sold separately.
C ₈	Appliance connected, through the exhaust pipe, to an individual or collective conventional flue. A second pipe is provided for the intake of combustion air from outside.
C ₉	Appliance connected, through a ducted exhaust pipe, to a vertical terminal. The exhaust pipe, by means of the cavity, also acts as a combustion air intake pipe.



1.39 IMMERGAS FLUE SYSTEMS

Immergas supplies various solutions separately from the appliances regarding the installation of air intake and flue exhaust terminals, which are fundamental for appliance operation.

These solutions form an integral part of the product.



The appliance must be installed with an original Immergas "Green Range" inspectionable air intake system and flue gas extraction system made of plastic, with the exception of configuration C₆ in the configurations envisaged in Parag. 1.38, as required by the regulations in force and by the product's approval. This flue can be identified by an identification mark and special distinctive marking bearing the note "only for condensation boilers".

For non-original flue system, refer to the technical data of the appliance.



The plastic pipes cannot be installed outdoors, for tracts longer than 40 cm, without suitable protection from UV rays and other atmospheric agents.

Air intake takes place directly from the room in which the appliance is installed by means of an intake mushroom or cover kit and flue gases are discharged into a single chimney or directly outside. By using the cover kit, it is possible to install the unit in a completely open area. The device in these configurations is classified as type B.

With this configuration:

- air intake takes place directly from the environment in which the appliance is installed and only functions in permanently ventilated rooms;
- the flue gas exhaust must be connected to its own individual chimney and channelled directly into the external atmosphere.

Positioning the gaskets (black) for "green range" flue systems.

Position the gasket correctly (for bends and extensions) (Fig. 39):

- gasket (A) with notches, to use for bends;
- gasket (B) without notches, to use for extensions.

If necessary, to ease the push-fitting, spread the elements with commonly-used talc.

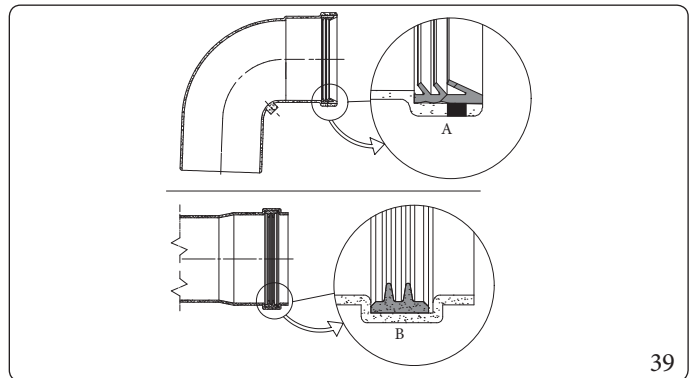

For safety purposes, do not even temporarily obstruct the appliance intake/exhaust terminal.









The various parts of the flue system must be checked to ensure that they have been laid in such a way as to prevent the coupled parts from detaching, in particular, the flue exhaust duct in the Ø160 separator kit configuration; if the above condition is not adequately guaranteed, it will be necessary to resort to the specific anti-slip clamp kit.



When installing horizontal pipes, a minimum inclination of 5% towards the appliance must be maintained, and a section clamp with plug must be installed every 3 metres.



1.40 EQUIVALENT LENGTHS OF "GREEN RANGE" FLUE SYSTEM COMPONENTS.

Equivalent lengths for split Ø 160mm			
Duct Ø [mm]	Type of duct	Picture	Equivalent length in m of pipe Ø 160mm
Ø 160/160	Pipe Ø 160 m 1		Exhaust m 1.00 Intake m 0.90
	Ø 160 90° bend		Exhaust m 2.20 Intake m 2.10
	Ø 160 45° bend		Exhaust m 1.00 Intake m 0.90
	Horizontal terminal Ø 160 m 0,7		Intake m 1.20
	Stainless steel vertical terminal Ø 160 m 1		Exhaust 2,00 m
	Plastic vertical terminal Ø 160 m 1		Exhaust 2,00 m
	Intake stub pipe Ø 160		Intake m 1.00
	Thermoformed intake kit with configuration B		Intake m 1.00

INSTALLER

USER

MAINTENANCE TECHNICIAN

TECHNICAL DATA



1.41 MAXIMUM FLUE LENGTH



To calculate the equivalent length of the flue (L), simply add, for each component that you intend to use, the corresponding value indicated in the "Equivalent length in m of pipe" column of the table in par. 1.40, and check that the resulting sum is equal to or less than the maximum length (L max) indicated in this paragraph ($L \leq L_{max}$).



Should L be higher than L max, consider using another type of flue.

Type	Installation	VICTRIX PRO V2 180 EU
		L = Maximum length (m)
Ø 160/160mm	C ₄₃ - C ₅₃ - C ₈₃ (split)	8
	B ₂₃ - B _{23p} - B ₃₃ - B ₅₃ - B _{53p}	8

Note: B₂₃ - B_{23p} - B₅₃ - B_{53p}: maximum flue length valid both for thermoformed intake kit and that with intake terminal B₂₃.



In Ø160 and Ø160-160 configurations, the maximum length does not include elbows and terminals.



1.42 OUTDOOR INSTALLATION



All optional kits that can be potentially connected to the boiler must be protected on the basis of their electrical protection rating.



This unit can be installed outdoors in a partially protected location or in the open using the cover kit (optional). By partially protected area, we mean one in which the unit is not directly exposed to the elements (rain, snow, hail, etc.).



If the appliance is installed in a location where the ambient temperature falls below -5°C , use the optional antifreeze kit, checking the ambient temperature range for operation in the technical data table in this instruction manual (Section 'Technical Data').

INSTALLER

USER

MAINTENANCE TECHNICIAN

TECHNICAL DATA

Configuration type B, open chamber and fan assisted (B₂₃, B_{23p}, B₃₃, B₅₃, B_{53p}).

Using the relevant cover kit, direct air intake is possible and flue gas is exhausted into a single chimney or directly to the outside. In this configuration the appliance can be installed in a completely open place. In this configuration the appliance is classified as type B.

With this configuration:

- the flue gas exhaust must be connected to a single chimney or ducted directly to the external atmosphere via a vertical terminal for direct exhaust (B₂₃);
- B_{23p}, B_{53p}: installation type B₂₃ and B₅₃ with connection to an exhaust system designed to operate with positive pressure.

Cover kit assembly (Fig. 40).

- Remove the cap on the suction hole (Fig. 40) by unscrewing the 4 fixing screws;
- Install the cover kit by fastening it with the 6 screws inside, interposing the relevant gaskets;
- Couple the 90° Ø 160 bend with male side (smooth), through the kit gasket, on the flue gas connection of the appliance until it is brought to the end stop;
- Tighten the gasket using the clip present, taking care to secure the 4 feather keys of the gasket.
- Fit the male end (smooth) of the exhaust pipe into the female end of the 90° bend, making sure that the relevant wall sealing plate is already fitted; this will ensure hold and joining of the elements making up the kit.

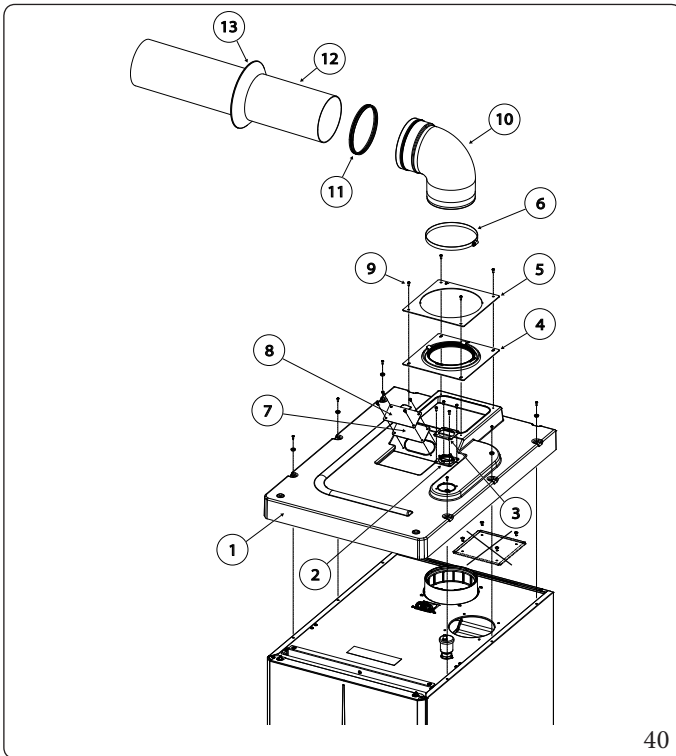

The cover kit includes (Fig. 40):

- N°1 Thermoformed cover (1)
- N°1 Air vent gasket (2)
- N°1 Air vent gasket locking plate (3)
- N°1 Flue exhaust gasket (4)
- N°1 Flue exhaust gasket locking flange (5)
- N°1 Stainless steel clip for flue gas seal (6)
- N°1 Manhole seal (7)
- N°1 Sheet metal manhole cover (8)
- N°12 Self-tapping screw (9)

The terminal kit includes (Fig. 40):

- N°1 Ø 160 90° bend (10)
- N°1 Gasket Ø 160 (11)
- N°1 Exhaust pipe Ø 160 (12)
- N°1 Wall sealing plate (13)



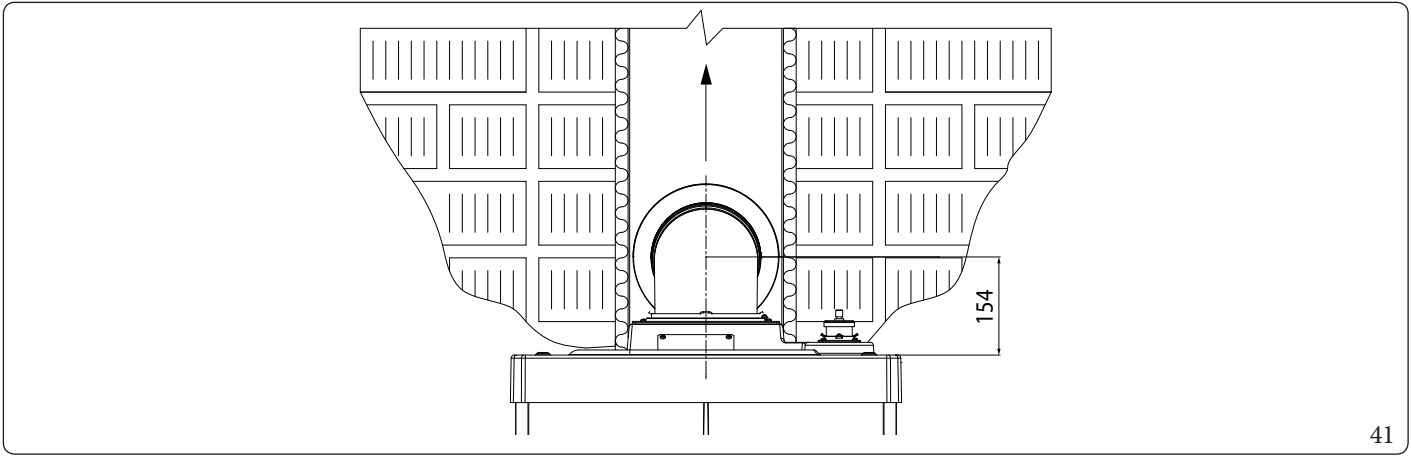

i The maximum lengths ((L.max) of the various flues that can be installed are given in the summary table in parag. 1.41.

Coupling of extension pipes.

To install push-fitting extensions with other elements of the flue, proceed as follows: Couple the pipe or elbow with the male side (smooth) in the female side (with lip seal) to the end stop on the previously installed element. This will ensure sealing efficiency of the coupling. With installations under a balcony, the X+Y+Z+W height evaluated with regard to the balcony above must be equal to or greater than 2000 mm (Fig. 42, 43).

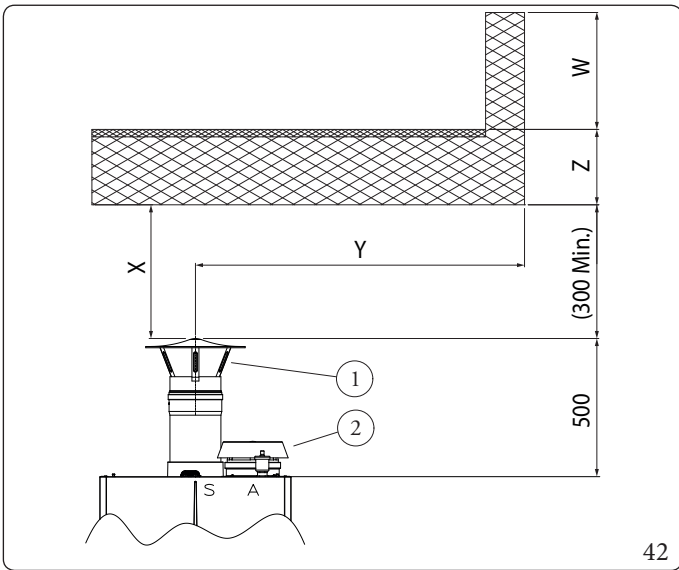

Key (Fig. 42):
 1 - Vertical exhaust kit Ø 160
 2 - Intake stub pipe kit Ø 160

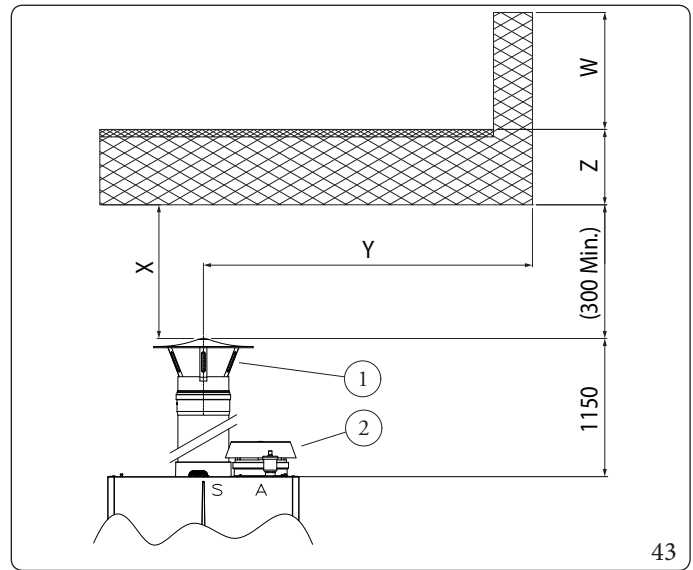

Key (Fig. 43):
 1 - Stainless steel vertical drain kit Ø 160
 2 - Intake stub pipe kit Ø 160



1.43 INTAKE STUB PIPE KIT INSTALLATION FOR TYPE B CONFIGURATIONS



In order to be able to install the type B exhaust kits, it is necessary to purchase the intake stub pipe kit (optional) with the appropriate diameter depending on the model being installed. For installation, see Fig. 44.

Installation of the intake stub pipe kit (Fig. 44)

Unscrew the screws (1) securing the Ø 160 intake cap (2);

1. Remove the factory-assembled suction cap (2);
2. Place the gasket (5) of the stub pipe kit on the newly freed intake hole;
3. Place the stub pipe (4) on top of the gasket (5) and fasten it to the pre-drilled holes in the frame of the appliance, using the screws (3).

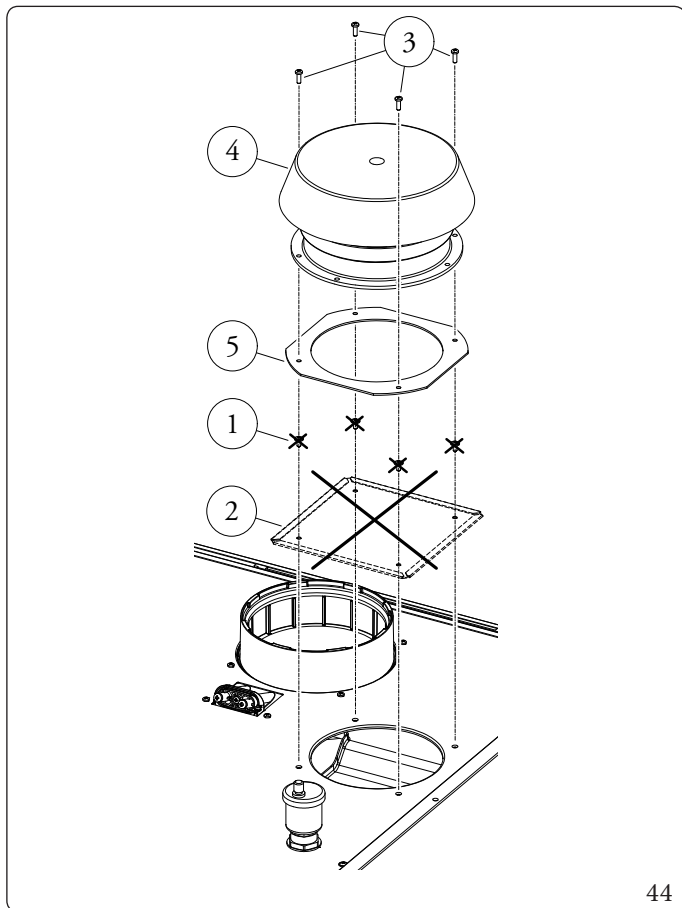

Key (Fig. 44):

1	-	Suction cap fixing screws
2	-	Intake cap
3	-	Stub pipe kit fixing screws
4	-	Intake stub pipe
5	-	Stub pipe gasket

44



1.44 INSTALLATION OF VERTICAL TERMINALS Ø 160



In order to be able to install the type B exhaust kits, it is necessary to purchase the intake stub pipe kit (optional) with the appropriate diameter depending on the model being installed. For installation, see Fig. 44.

Configuration type B, open chamber and fan assisted

Vertical kit assembly Ø 160 (Fig. 45)

1. Insert the gasket (2) into the exhaust pipe (3);
2. Install the terminal Ø 160 (1) in the exhaust pipe (3);
3. Insert the kits are just prepared on the flue gas connection of the appliance up to the end stop, making sure that the wall sealing plate (4) has been fitted. This will ensure the sealing efficiency of the kit components.

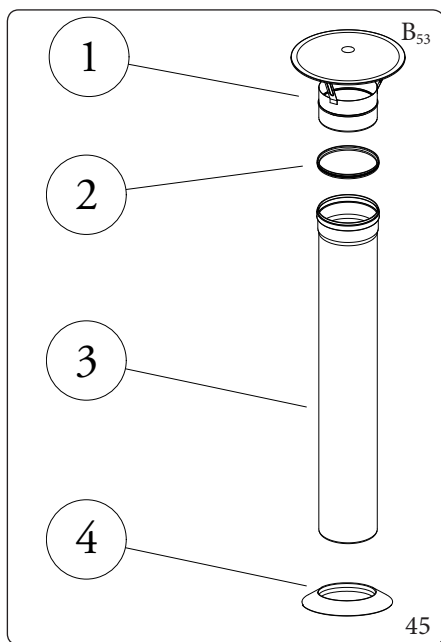

The Kit includes (Fig. 45):

- N°1 Exhaust terminal Ø 160 (1)
- N°1 Gasket Ø 160 (2)
- N°1 Exhaust pipe Ø 160 (3)
- N°1 Wall sealing plate (4)

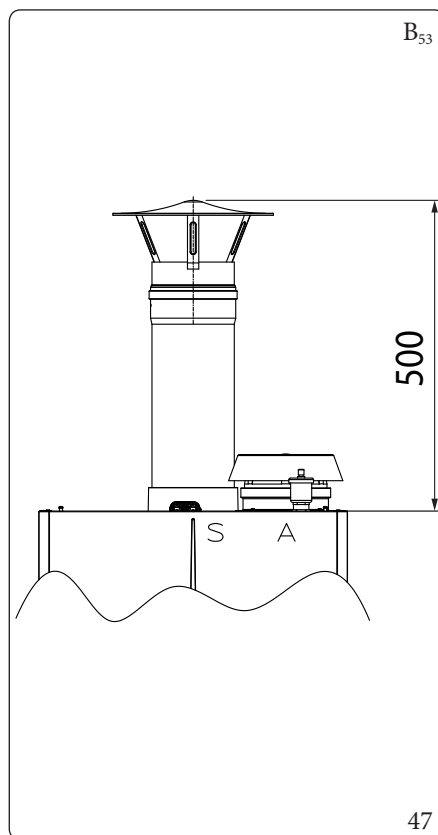
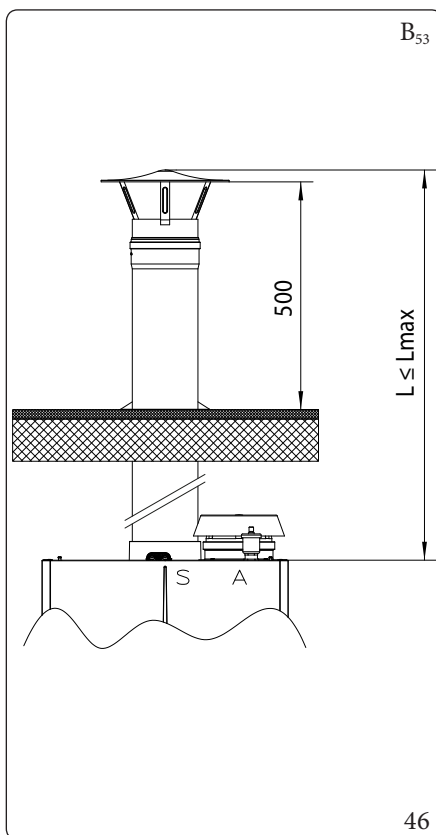

Extensions for vertical kit Ø 160 (L = Length - L max = Maximum length) (Fig. 46).



The maximum lengths ((L max) of the various flues that can be installed are given in the summary table in parag. 1.41.

When using the Ø 160 vertical terminal for direct exhaust of combustion products, the terminal must be shortened (see dimensions Fig. 47)

INSTALLER

USER

MAINTENANCE TECHNICIAN

TECHNICAL DATA



Ø160 vertical kit installation (in stainless steel) (Fig. 48)

4. Insert the gasket (2) into the exhaust pipe (3);
5. Install the terminal Ø 160 (1) in the exhaust pipe (3);
6. Insert the kits are just prepared on the flue gas connection of the appliance up to the end stop, making sure that the wall sealing plate (4) has been fitted. This will ensure the sealing efficiency of the kit components.

The 160 Ø steel terminal is used to install the boiler outdoors with a direct exhaust. The terminal cannot be shortened and once it is installed it will extend out by 1150 mm (Fig. 49).

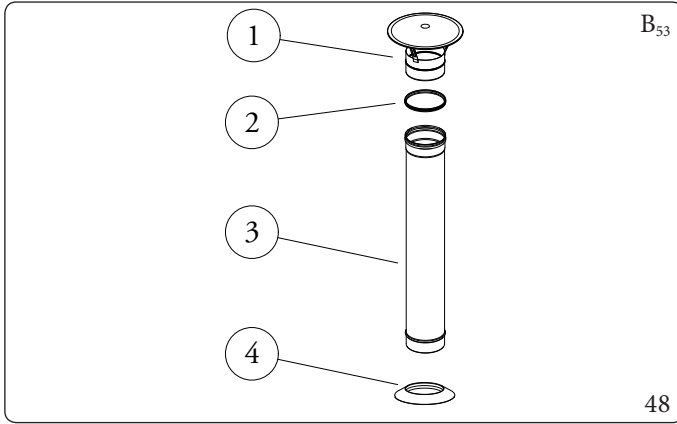

The kit includes (Fig. 48):

- N°1 Steel exhaust terminal Ø 160 (3)
- N°1 Gasket Ø 160 (2)
- N°1 Steel exhaust pipe Ø 160 (1)
- N°1 Wall sealing plate Ø 160 (4)

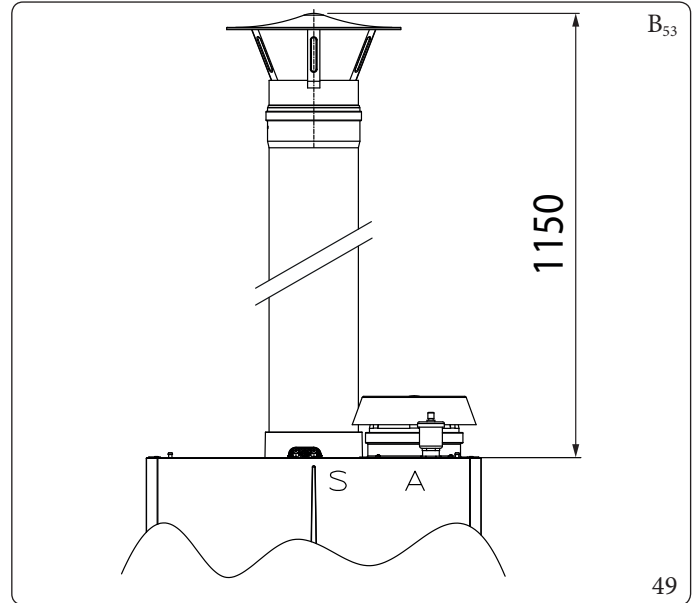

1.45 INSTALLATION OF 160 Ø HORIZONTAL TERMINALS

Configuration type B, open chamber and fan assisted

Installation of horizontal kit Ø160 with wall flue exhaust (Fig. 50)

1. Insert the gasket (2) into the corresponding seat of the 90° Ø 160 bend (1);
2. Couple the 90° Ø 160 bend (1) with male side (smooth), on the flue gas connection of the appliance until it is brought to the end stop;
3. Fit the exhaust pipe (3) with the male end (smooth) to the female end of the bend (1) up to the end stop; making sure that the internal wall sealing plate (4) has been fitted. This will ensure sealing and joining of the elements making up the kit.

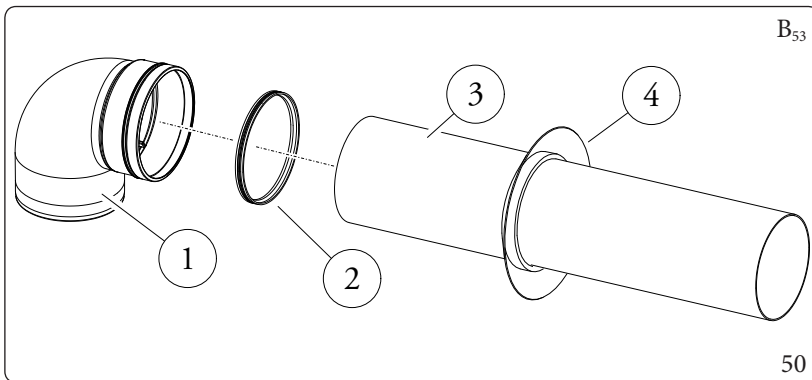

The Kit includes (Fig. 50):

- N°1 Ø 160 90° bend (1)
- N°1 Gasket Ø 160 (2)
- N°1 Exhaust terminal Ø 160 (3)
- N°1 Internal wall sealing plate (4)



The maximum lengths ((L max) of the various flues that can be installed are given in the summary table in parag. 1.41.

Installation of horizontal kit Ø160 with exhaust in single chimney (Fig. 51)

1. Insert the gasket (2) into the corresponding seat of the 90° Ø 160 bend (1);
2. Couple the 90° Ø 160 bend (1) with male side (smooth), on the flue gas connection of the appliance until it is brought to the end stop;
3. Fit the exhaust pipe (3) with the male end (smooth) to the female end of the bend (1) up to the end stop; making sure that the internal wall sealing plate (4) has been fitted. This will ensure sealing and joining of the elements making up the kit.

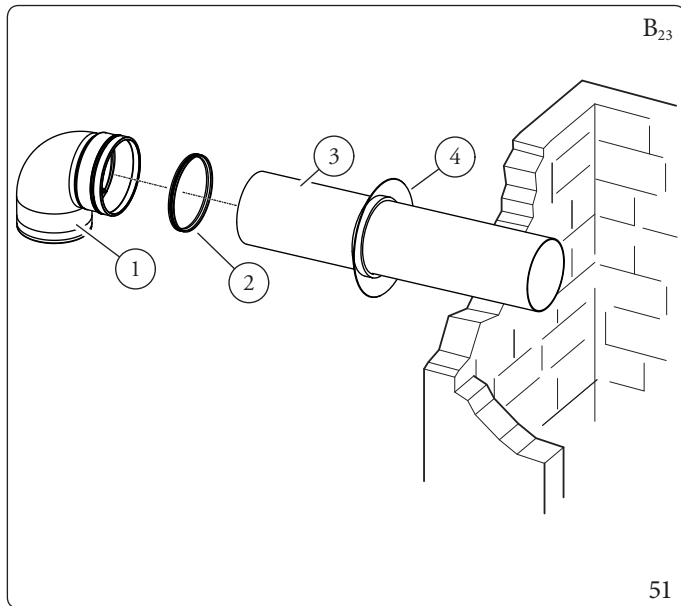

The kit includes (Fig. 51):

- N°1 Ø 160 90° bend (1)
- N°1 Gasket Ø 160 (2)
- N°1 Exhaust pipe Ø 160 (3)
- N°1 Wall sealing plate (4)

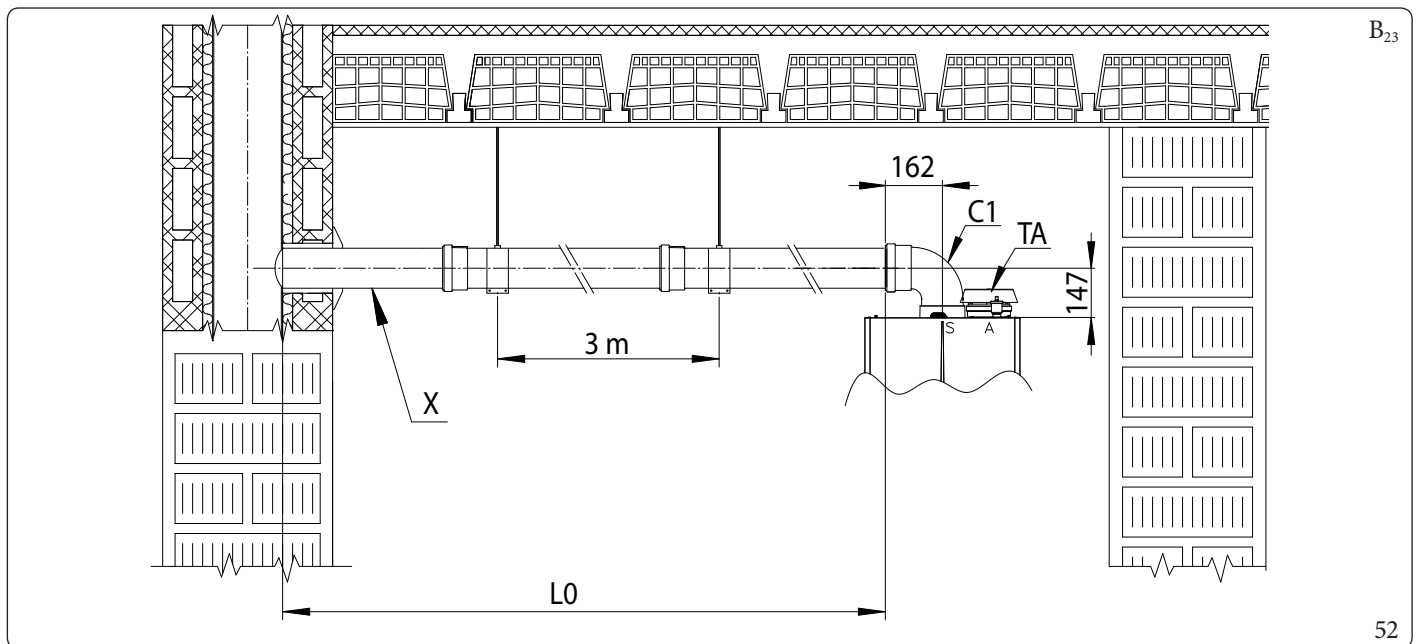

Key (Fig. 52):

- X = Minimum gradient 5%
- A = Intake
- S = Exhaust
- TS = Exhaust terminal
- TA = Intake terminal
- C1 = Elbow 1

$$L_{\max} \leq L_0 + C_1 + TA$$



The maximum lengths ((L max) of the various flues that can be installed are given in the summary table in parag. 1.41.



1.46 SEPARATOR KIT INSTALLATION

Type C configuration, sealed chamber and fan assisted separator kit Ø 160/160

This kit allows air to come in from outside the building and the exhaust to exit from the chimney, flue or intubated duct through divided flue exhaust and air intake pipes.

Combustion products are expelled from pipe (S) (in plastic, so as to resist acid condensate).

Air is taken in through duct (A) for combustion (this is also in plastic).

The intake pipe (A) can be installed either on the right or left hand side of the central exhaust pipe (S).

Both ducts can be routed in any direction.

Assembly of separator kit Ø 160/160 (Fig. 53):

1. Remove the factory-assembled suction cap;
2. Install the flange (2) on the suction hole of the unit, interposing the adhesive gasket (1);
3. Tighten using the self-tapping screws supplied;
4. Engage the bends (3) with male (smooth) side respectively, into the female side of the flanged stub pipe (2) and into the exhaust hole of the appliance;
5. Fit the intake terminal (4) with the male side (smooth) in the female side of the bend (3) up to the end stop, ensuring that the internal and external wall sealing plates are fitted;
6. Fit the exhaust pipe (6) in the female end of the bend (3) up to the end stop, making sure that the internal wall sealing plate has been fitted, this will ensure sealing and joining of the kit elements.

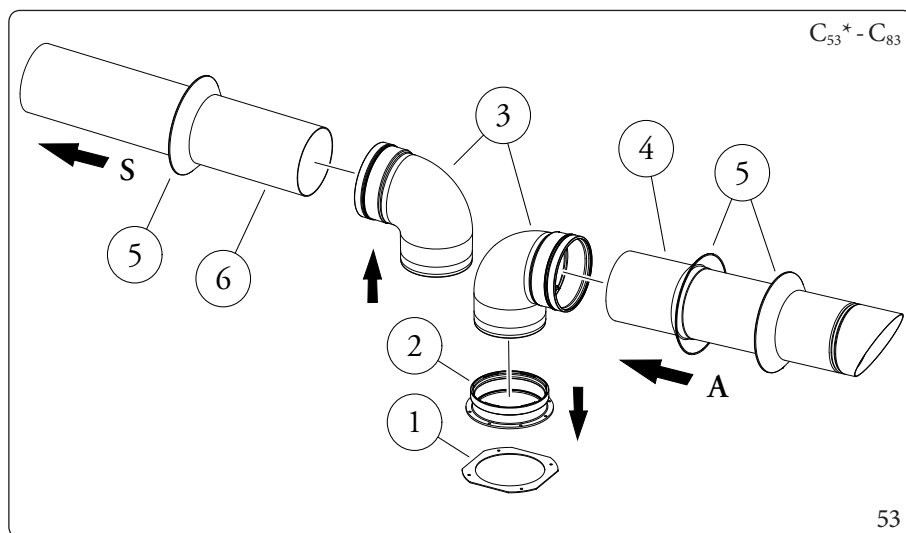

The kit includes (Fig. 53):

- N°2 Ø 160 90° bend (3)
- N°1 Intake flange Ø 160 (2)
- N°1 Intake terminal Ø 160 (4)
- N°3 Wall sealing plate Ø 160 (5)
- N°1 Exhaust pipe Ø 160 (6)
- N°1 Adhesive gasket (1)

* to complete C₅₃ configuration, also provide for a "green range" roof discharge terminal. The configuration on walls opposite the building is not allowed.

Installation clearances (Fig. 54)

The minimum installation clearance measurements of the Ø 160/160 separator kit have been stated in some limit conditions.

* Configuration C₄ envisages connection to flues working with natural draught.



For technical data concerning configuration C₄ please refer to the table in par. 4.3.

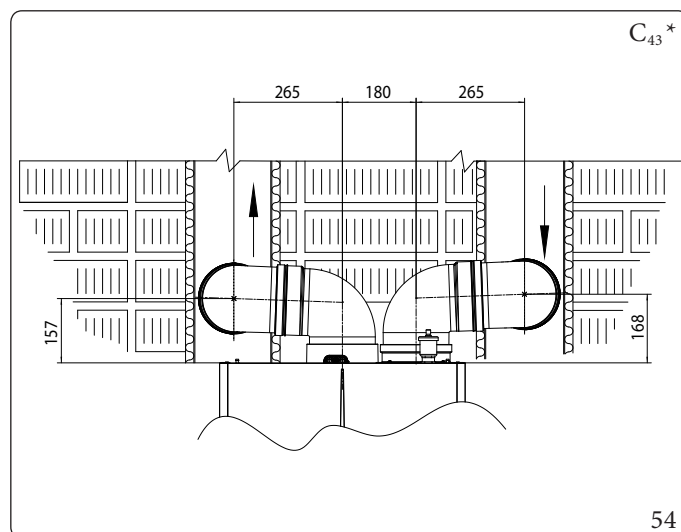

Extensions for separator kit Ø 160/160 (L max = maximum length)

Please note the type of installation C₄₃ must be done with a natural draught flue.



To aid in the removal of possible condensate forming in the exhaust pipe, tilt the pipes towards the appliance with a minimum slope of 5% (Fig.55).

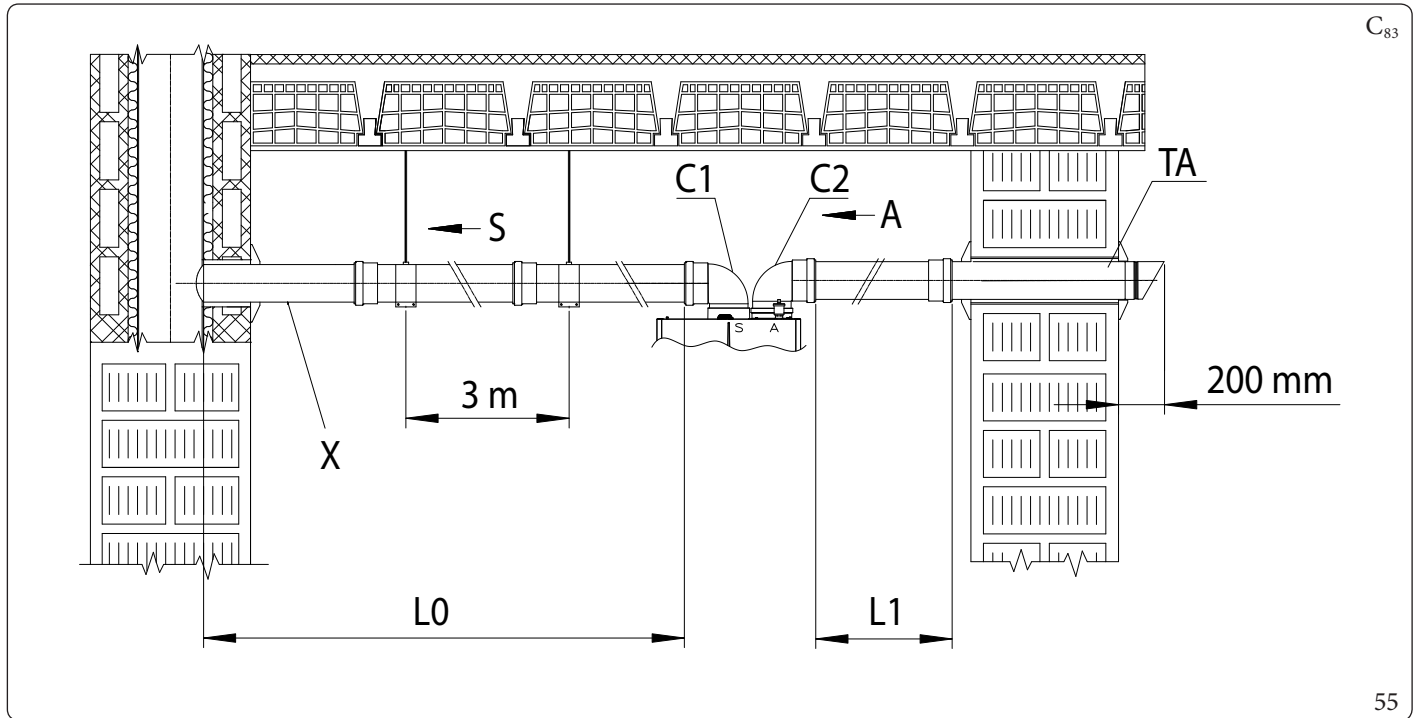

Key (Fig. 55):

- A - Intake
- X - Minimum slope 5%
- S - Exhaust
- C1 - Bend 1
- C2 - Bend 2
- TA - Intake terminal

$$L_{max} \leq L_0 + L_1 + C_1 + C_2 + TA$$



The maximum lengths ((L max) of the various flues that can be installed are given in the summary table in parag. 1.41.

INSTALLER

USER

MAINTENANCE TECHNICIAN

TECHNICAL DATA



Installation example

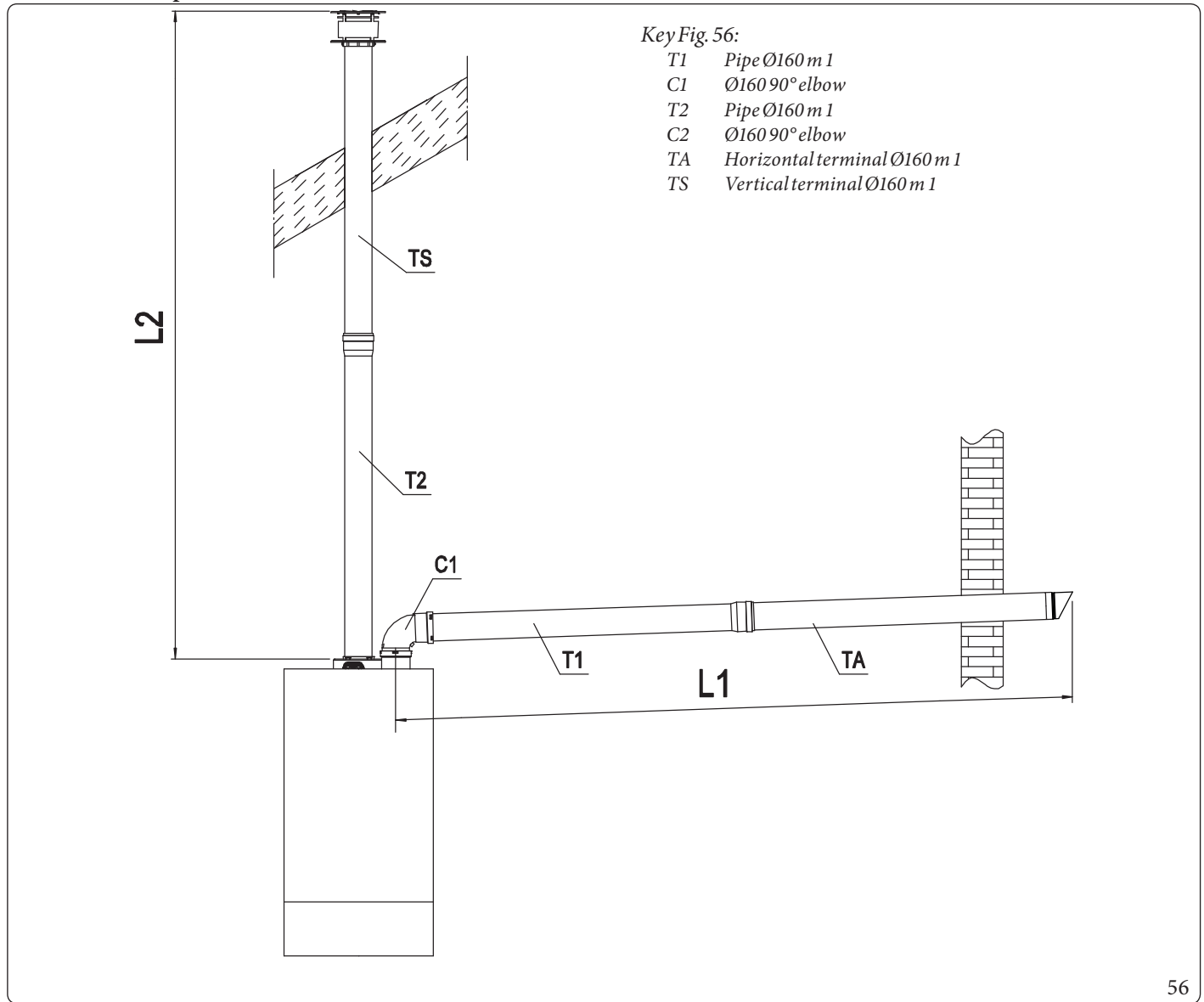

56

Example:

$$L = L1 + L2 = (T1 + C1 + TA) + (T2 + TS) = (0,90 + 2,10 + 1,20) + (1 + 2) = 7,2 \text{ m}$$

$$L \leq L_{\text{max}} - 7,2 \text{ m} \leq 8 \text{ m}$$



To calculate the equivalent length of the flue (L), simply add, for each component that you intend to use, the corresponding value indicated in the "Equivalent length in m of pipe" column of the table in par. 1.40, and check that the resulting sum is equal to or less than the maximum length (L_{max}) indicated in this paragraph ($L \leq L_{\text{max}}$).

1.47 CONFIGURATION FOR C₆ FLUE INSTALLATION

Appliance designed to be connected to a commercial exhaust/intake system.

Gas type		NG (G20)
Flue temperature at maximum output	°C	72
Flue gas mass at maximum power	kg/h	277
Flue temperature at minimum output	°C	60
Flue gas mass at minimum power	kg/h	60
CO ₂ at Q. max.	%	9,1 (9,0 ÷ 9,4)
CO ₂ a Q. minimum	%	8,5 (8,2 ÷ 8,6)
Maximum head available at maximum power (maximum resistance value of the commercial flue system)	Pa	41
Maximum head available at minimum power	Pa	2
Maximum temperature that the exhaust pipes can reach	°C	120



- Ducts must withstand condensation (only for condensing models);
- Air intake ducts must withstand working air temperatures of up to 60°C;
- The maximum permissible percentage of flue gas recirculation in windy conditions is 10%;
- Suction and exhaust pipes cannot be installed on opposing walls;
- With flues in configuration C₆ discharge into pressurised flues is not permitted.

INSTALLER

USER

MAINTENANCE TECHNICIAN

TECHNICAL DATA



1.48 WATER TREATMENT PLANT FILLING

The current technical standards in force prescribes the washing and treatment of the water in the heating and water system (when combined with a boiler unit), following the methods indicated and the requirements of the local regulations in force.

The parameters that influence the duration and proper operation of the heat exchanger are the water's PH, total hardness, conductivity, and oxygen, together with the system's processing residues (any welding residues), any oil present and corrosion products that can, in turn, cause damage to the heat exchanger.

In order to prevent this from happening, you are recommended to:

- Before installation on new systems as well as old ones, clean the system with clean water to eliminate solid residues.
- clean the system with a chemical treatment:
 - clean the new system with a suitable cleaning device (for example Sentinel X300, Fernox Cleaner F3 or Jenaqua 300) combined with thorough washing;
 - clean the old system with a suitable cleaning device (for example Sentinel X400 or X800, Fernox Cleaner F3 or Jenaqua 400) combined with thorough washing;
- Check the maximum total hardness and amount of filling water with reference to the graph (Fig. 57), if the contents and hardness of the water are below the indicated curve, no specific treatment is required; otherwise, to limit the content of calcium carbonate, you must provide for water-filling treatment.
- If it is necessary to provide for water treatment, it should be done through complete desalination of the filling water. As opposed to the complete softening process, desalinating the water completely not only removes hardening agents (Ca, Mg), but also eliminates all other minerals to reduce water-filling conductivity up to 10 microsiemens/cm. Given its low conductivity, desalinated water does not only prevent the formation of lime scale, but also serves as protection against corrosion.
- Insert a suitable inhibitor / passivator (for example Sentinel X100, Fernox Protector F1, or Jenaqua 100); if required, also insert appropriate antifreeze (such as for example Sentinel X500, Fernox Alphi 11 or Jenaqua 500).
- Check electrical conduction of the water, which should be higher than 2000 $\mu\text{s}/\text{cm}$ in the case of treated water and lower than 600 $\mu\text{s}/\text{cm}$ in the case of non-treated water.
- To prevent corrosion, the water system's PH should be between 7.5 and 9.5.
- Check the maximum content of chlorides, which should be less than 250 mg/l.



For quantities and methods of use of water-treatment products, refer to the instructions provided by their manufacturer.

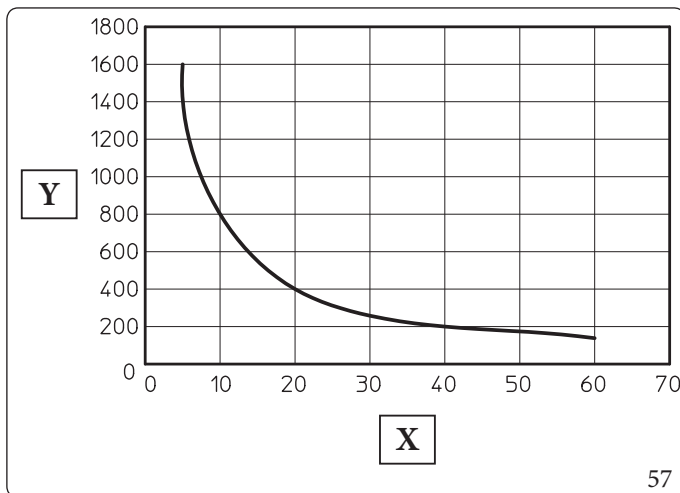

Key (Fig. 57):

- X - Total water hardness °F
- Y - Litres of system water



The graph refers to the entire life cycle of the system. Therefore, also consider scheduled and unscheduled maintenance, which involves emptying and filling the said system.

1.49 SYSTEM FILLING

Once the device is connected, proceed with filling the system.

Filling is performed at low speed to ensure release of air bubbles in the water via the appliance and central heating system vents.

The appliance has a built-in automatic vent valve (Parag.1.64).

Check if the cap is loose.

Then open the radiator vent valves.

Close radiator vent valves when only water escapes from them.



During these operations, use the deaeration functions (Parag. 1.57).



This appliance is not equipped with an expansion vessel on the system. It is mandatory to install a closed expansion vessel to guarantee correct appliance operation. The expansion vessel must comply with current local standards in force. The dimensions of the expansion vessel depend on the data relative to the central heating system. Install a vessel whose capacity responds to the requisites of the Standards in force.

1.50 FILLING THE CONDENSATE DRAIN TRAP



When the appliance is switched on for the first time, combustion products come out of the condensate drain. After a few minutes of operation, check that combustion flue gases are no longer coming out of the condensate drain; this means that the drain trap has filled to a correct condensate height that the flue gases cannot pass through.

1.51 OPERATION WITH SYSTEM FLOW SENSOR

In the presence of a hydraulic separator, a System sensor must be provided.

The system sensor is connected to terminals S1 and S2 and must be configured via the parameter "System sensor" (Technician menu/HYDRAULIC SETTINGS).

One or more circulators must in any case be provided downstream of the hydraulic separator.

See the relevant example installation wiring diagrams (relating to single boiler and simple cascade) in the installer chapter.

If the system flow sensor fails, the system will still function but with reduced performance.

The corresponding error will also be shown on the display.



See the relevant example installation wiring diagrams (relating to single boiler and simple cascade) in the installer chapter.



If the system flow sensor fails, the system will still function but with reduced performance. The corresponding error will also be shown on the display.



The parameter "PI loop period" slows down or speeds up the response of the control system, but be careful as it can make the system's response unstable or too slow.



1.52 SIMPLE CASCADE

By connecting two or more boilers electrically via BUS, a simple cascade can be configured.

Each request alternates the sequence in which the appliances are ignited. The amount of activated appliances and their power is managed according to the needs of the system.

Make the BUS connection as shown in the diagram (Fig. 37).

A system flow sensor is required in this configuration, see relevant example installation wiring diagrams in the cascade booklet.



If you want to set a DHW-only hydraulic configuration (DHW pump), the system flow probe must also be set for heating in any case (on the Master unit see Technician menu/HYDRAULIC SETTINGS/System sensor) otherwise error 89 will appear on the display.

The DHW-only setting for the system flow probe can only be implemented with the single unit.



If the system flow probe fails, the system will still function but with reduced performance (the flow probe of the pin appliance is taken as the reference for cascade operation).

The corresponding error will also be shown on the display.



To avoid wear and tear on the Master appliance, the Ignition sequence of the devices is alternated automatically. The appliance that activates first in the sequence is referred to as 'Pin'.

The switch-on sequence of the appliances is different depending on whether there is a demand for domestic hot water or central heating. In the case of a CH Demand, the first appliance (Pin appliance), is switched on and if necessary the others in sequence, running them all at the same power after the first period after the ignition cycle.

The sequence of switching off the devices is the reverse of the one just described.

In the case of DHW Demand, the system switches on all appliances in rapid sequence, making them all operate at the same power.



The activation/deactivation sequence of the devices is managed by the control algorithm and some of the parameters contained in the cascade menu.

In order for the system to recognise the appliances in simple cascade, it is necessary to do the auto-detection from the Master appliance (present in the technical-cascade menu).

Parameter customisation should be done from the Master appliance and only after cascade configuration.

Language and units of measurement, for example, are not present in the menu of the Slave appliances, so they must be configured on the Master appliance, after configuration of the cascade.

These parameters mentioned above (as well as all custom parameters that can be synchronised), can however be updated, and thus synchronised, at a later date.

In the simple cascade, however, there is a parameter synchronisation procedure from Master to Slave.

If one or more of the appliances Slave are faulty, the appliance Master will automatically operate the remaining Slave. In the event of a failure of Master, simple cascade operation is not always guaranteed.

However, it is possible (after modifying the BUS and electrical connections) to assign the role of Master to one of the functioning Slave, repeating the self-detection function from the 'new' device Master.



All electrical connections of sensors, circulators, valves, thermostats (heating and DHW) must be made on the Master appliance.



In Cascade Simple configuration, the cascade and zone regulator kit must not be present.



Boilers in simple cascade must be of the same output and modulation range.



In order for the system to recognise the appliances in simple cascade (after the electrical connections have been made), it is necessary to run auto-detection from the Master appliance (found in the technician/cascade menu).



Single appliance anti-freeze protection

The boiler anti-freeze protection parameters are set by Master and are used by each individual appliance.

Each individual appliance in the cascade can activate its own anti-freeze protection function, which then works independently of the other appliances.

Activation of the anti-freeze protection for one or more appliances is indicated on the Master's main screen as if it were a heating request, while MENU/Boiler state appears in "Antifreeze protection".



This protection does not activate the pumps after the hydraulic circuit breaker but only activates the booster pump.

Parameter configuration

Parameter customisation should be done from the Master appliance and only after auto-detection (see paragraph 1.53), with Slave appliances switched on.

When customising the parameters, some are also modified (synchronised) in the Slave appliances. Not all parameters synchronised on the Slave are used by the Slave themselves.

An example of parameters synchronised and used on the Slave are the language and the unit of measurement. These parameters are not present in the menu of the Slave appliances, which is why, when changing these parameters on the Master appliance, they are also changed on the Slave appliances.

These parameters mentioned above (as well as all custom parameters that can be synchronised), can however be updated, and thus synchronised, at a later time (see paragraph 1.54).

Certain parameters can be changed on each individual Slave.



At the end of parameter customisation on the Slaves, it is normal for the Master appliance to temporarily present error 99. This is due to the update of the parameters on the Slave appliance.

Re-configuring an appliance as single

If a Master or Slave appliance is to be switched back to a single appliance, follow the procedure outlined in paragraph 1.54.



The single unit is still referred to as Master.

After configuring the appliance as an individual, it may be necessary to modify those previously customised parameters and then return them to their initial conditions.

In this case, apply the reset settings function.

After performing the reset function, it is however important, to check that the factory pre-set parameters for the appliance (e.g. fan speed) are respected.



All electrical connections of sensors, circulators, valves, thermostats (heating and DHW) must be made on the Master appliance.



In this configuration, the cascade and zone regulator cannot be combined with the system.



appliances in simple cascade must be of the same output and modulation range.



1.53 AUTODETECTION

This function makes it possible to detect and associate appliances in cascade in the case of simple cascade installation. It also serves to assign the role of Master and Slave to devices in simple cascade or, to revert to a single configuration from simple cascade.



Ensure that the communication BUS for simple cascade has been connected as in the diagram in Fig. 37.



The Master appliance in the cascade configuration and the Master appliance in the single appliance configuration differ in that auto-detection was performed in the two different contexts.

In order to assign the role in the cascade of individual appliances, switch them on (if the appliances have been on for more than 5 minutes, they must be switched off and back on), access from the appliance Master, to Technician menu/Cascade/Autodetect.

The Master appliance directly displays Master (if not, use the buttons \wedge and \vee to select Master, then confirm with 'OK'.

Within 1 minute the Slave appliances, will present the menu for role assignment, then assign the role to each individual Slave appliance (the assignment numbering must necessarily be consecutive, i.e. without number jumps).

Only at this point is it possible to give the OK to the Master appliance, thus starting the self-detection which lasts approximately two minutes.

Ensure that the appliance Master has detected the total number of units in simple cascade (Master+Slave).

If the number of detected devices is correct, the self-detection is finished and confirm with the 'OK' button on the boiler Master.

Finally, wait for the "C" parameter update phase to finish.

If this is not correct, pressing a button other than 'OK' on Master, the 'OK' button on Slave and then 'OK' again on Master, will repeat the procedure.

At this point, error 89 is displayed, which indicates that the system flow probe (system probe) remains to be set.

If the system flow probe is defective (see errors 91, 92), the system will still function but with reduced performance.



The successful assignment of roles is displayed on the main screen (see point 29 Fig. 62).



In case of problems, the procedure can still be repeated.



In the event that a double confirmation (OK) is erroneously given when assigning the role to the Slave appliance, simply wait for the role assignment screen to reappear.

This also applies if the role was incorrectly assigned to Slave and you want to correct it without repeating the procedure from the beginning.

Single appliance configuration

If you want to revert to single appliance configuration, you must switch off all other appliances and then repeat the auto-detection procedure, making sure to set it as Master.

In this case, the total number of recognised appliances must be equal to 1 (recognition correctly as a single appliance).

Once the appliance has been configured as a single appliance, the Reset Settings function can help to reset many parameters previously modified from Simple Cascade to default values



If one or more Simple Cascade appliances have been configured as single, it is assumed that the Simple Cascade communication BUS is removed for their operation

1.54 RESTORE SETTINGS AND PARAMETER SYNCHRONISATION

Parameter reset, returns the parameters in the Master appliance to their factory settings (or to a pre-set value) (see “Restore settings” in the relative tables of paragraphs 2.9 and 3.7) and at the same time, synchronises the parameters in the Slave appliances (see relative tables of paragraphs 2.9 and 3.7).

There are also two separate synchronisation functions for setting parameters from Master to Slave appliance(s):

- Parameter synchronization
- Single parameter synchronisation



For synchronisable parameters, see the Synchronisation column in the Slave appliances tables.



Before performing synchronisation operations, make sure that the cascade has been correctly detected by the Auto-detection function and that all boilers are switched on. This operation can only be performed from the Master appliance.

• Parameter synchronisation

This function is used, after the replacement of one or both boards of the Slave appliance, to quickly configure parameters.

There is a parameter on the Master appliance in "Technician menu/Cascade/Parameter synchronization" to perform synchronisation of the parameters.

This function causes certain parameters on the Master appliance to be changed in the Slave appliance(s). Some parameters are synchronised on the Slave appliance(s) but are not visible in the relative menu (visible when the appliance is configured as a single appliance). The list of synchronisable parameters can be seen in the Synchronisation column of the Slave menu table.

• Single parameter synchronisation

The parameters in the “Synchronisation” column of the Slave menu table are automatically changed on the Slave appliance(s) if they are changed on the Master appliance.

This function causes certain parameters on the Master appliance to be modified in the Master appliance(s), for correct operation of the simple cascade. Some parameters are synchronised on the Slave appliance(s) but are not visible in the relative menu (visible when the appliance is configured as a single appliance).



Some synchronisable parameters can be customised on the individual Slave appliance, however customisation is lost if one of these parameters is changed again by the Master appliance or the 'Parameter synchronization' function is activated.



1.55 HEATING ZONES

Using the appliance's P.C.B., two separate zones can be managed in CH mode, and one of these can be mixed.



The system flow probe is required and, in the case of the mixed zone, the low temperature flow probe is also required.



When using the system-side flow sensor and hydraulic separator, the flow temperature of the unit (or units in the case of simple cascade) is limited by the maximum permissible temperature (95°C).



For the low-temperature mixed zone, it is necessary to set the parameter "High temperature protection" and provide for the insertion in series with the zone pump supply, of a special safety kit (optional) consisting of a thermostat (with adjustable temperature, depending on the characteristics of the system).



For more details, see the relevant wiring diagrams.

1.56 OPERATION WITH DHW STORAGE TANK (OPTIONAL)

Via the appliance's circuit board, either a DHW pump for storage tank charging or a three-way valve can be controlled. The storage tank temperature can be controlled either by a DHW thermostat (dry contact), or by a DHW probe.



For the activation of the DHW demand, the parameter "DHW request type" must be adjusted according to the type of storage tank temperature control used.



For more details, see the relevant wiring diagrams.

1.57 VENTING

This function can help the system to release any air present.



If a hydraulic separator is used, deaeration is only carried out upstream of the separator.

By default, the automatic function is always active (cycle duration: 8 minutes). This function is activated every time the appliance is powered. This function can be permanently deactivated via parameter "Automatic function".

There are two parameters for manual activation of Deaeration:

- Manual shorter function (cycle duration: 8 minutes);
- Manual longer function (cycle duration: 18 hours).



Once the manual cycle is activated, the same timer will be present in both parameters and can be deactivated by both. The timer can be accessed, and therefore also deactivated, from the boiler status menu.

1.58 ANTI-LEGIONELLA

The menu "Antilegionella" is present if the parameter "DHW request type" is set as "Sensor".

The function must be enabled by the 'Function' parameter and the temperature read by the DHW probe must be lower than the setpoint parameter (anti-legionella) to be activated.

This function can be activated in three different ways:

- Manually force: manually activates the function;
- Period: The function is activated at intervals according to the 'Period' parameter;
- Scheduler set: If "Scheduler set" (User menu/Domestic hot water/Scheduler set) is activated, the function is activated with weekly cycle on the day as per parameter "Day of the week" and at the time as per parameter "Hour of the day".



The duration of the anti-legionella function is set in the parameter "Duration"; if the set setpoint is not reached within the time set in this parameter, a message appears on the display.



For this function to work properly, make sure that the date and time have been set correctly. In the event of a power failure, the time and date are guaranteed for about 8 hours (subject to continuous power supply for at least 24 hours), after which they are no longer guaranteed.

1.59 CONTINUOUS PUMP OPERATION IN HEATING MODE

The parameter "CH pump continuous operation" can be used to enable this function.

The function keeps the boiler circulator and booster pump (if present) active, even when there is no CH demand. The circulators are deactivated in the case of DHW priority, in "Standby" mode, with CH disabled (MODE button) and if the parameter "Outside temperature for CH off" is set and the function is activated.



The heating pumps of the zones are not activated by this function.



In the event of simultaneous activation of the "Anti-humidity function" electrodes and the "CH pump continuous operation" function, more heat than necessary is expelled from the chimney.

1.60 GAS SYSTEM START-UP

To start up the system, refer to the technical standards in force.

This divides the systems and, therefore, the commissioning operations, into three categories: new systems, modified systems, reactivated systems.

In particular, for new gas systems:

- open windows and doors;
- avoid presence of sparks or naked flames;
- bleed all air from pipelines;
- ensure the internal system is properly sealed according to the specifications set forth by technical regulations in force.



1.61 APPLIANCE START-UP (IGNITION)

To commission the appliance (the operations listed below must only be performed by qualified personnel and in the presence of staff only):

1. Check that the internal system is properly sealed according to the specifications set forth by regulations in force.
2. Ensure that the type of gas used corresponds to the appliance settings;
3. check that there is no air in the gas pipe;
4. check that there are no external factors that may cause the formation of fuel pockets;
5. Check the connection to a 230V 50Hz mains;
6. Switch the appliance on and check correct ignition;
7. **Check that the drain trap is full and that it prevents any passage of flue gas into the room;**
8. Make sure the fan rpm matches the value provided in the booklet (Par.4.1);
9. ensure that the safety device intervenes in the event of gas supply failure and check the relative intervention time;
10. Check the activation of the main switch located upstream of the appliance and in the appliance.
11. check that the intake/exhaust terminals are not obstructed and that they are installed properly;



Even if just one single safety check provides a negative result, do not commission the system.

1.62 CIRCULATION PUMP

• WILOSTRATOSPARAC pump

The appliances are supplied with a variable speed circulator pump.

With the appliance in central heating mode, the speed of the circulator modulates in this way:

- proportionally between the values set in parameters "Pump minimum speed" and "Pump maximum speed" in relation to the boiler output (0% - 100%);
- increasing the speed so that the boiler does not exceed the ΔT (between system flow and return) as per "Pump control" parameter.



With ΔT greater than the parameter "Pump control" the pump maintains maximum speed. For certain system types, it is advisable to set the parameters "Pump minimum speed" and "Pump start speed" to 100%.



In DHW mode, the pump always runs at the speed set in parameter "Pump maximum speed".



There is no LED on the pump.

If any of the following anomalies are present:

- Low power supply voltage.
- Rotor seized (Cautiously turn the screw in the centre of the head to manually release the motor shaft).
- Electrical error.

The relevant error will be indicated on the boiler display.



These anomalies will be signalled on the boiler display as errors "E85".

Pump release.

For these types of circulators, there are two release possibilities: automatic and/or manual.

• Automatic Unlocking

Pump blockage is signalled by error 85. The pump performs automatic unblocking attempts lasting 30 minutes, after which (in case of failure to release) it will be necessary to proceed with manual release.



If you want to have the automatic unlocking performed again, you have to disconnect power supply to the boiler for at least 30 seconds.

• Manual release

- Switch off the power supply to the boiler;
- Close the system flow and return and let the pump cool down;
- Empty the appliance from the relative drain point;
- Dismantle the motor and clean the impeller (do this very carefully so as not to damage it);
- After unlocking, reassemble the motor;
- Fill the primary circuit and restore power to the unit.
- Re-open system flow and return.



**A scalding hazard is present due to high fluid temperatures and pressures.
Scalding hazard as a result of contact.**



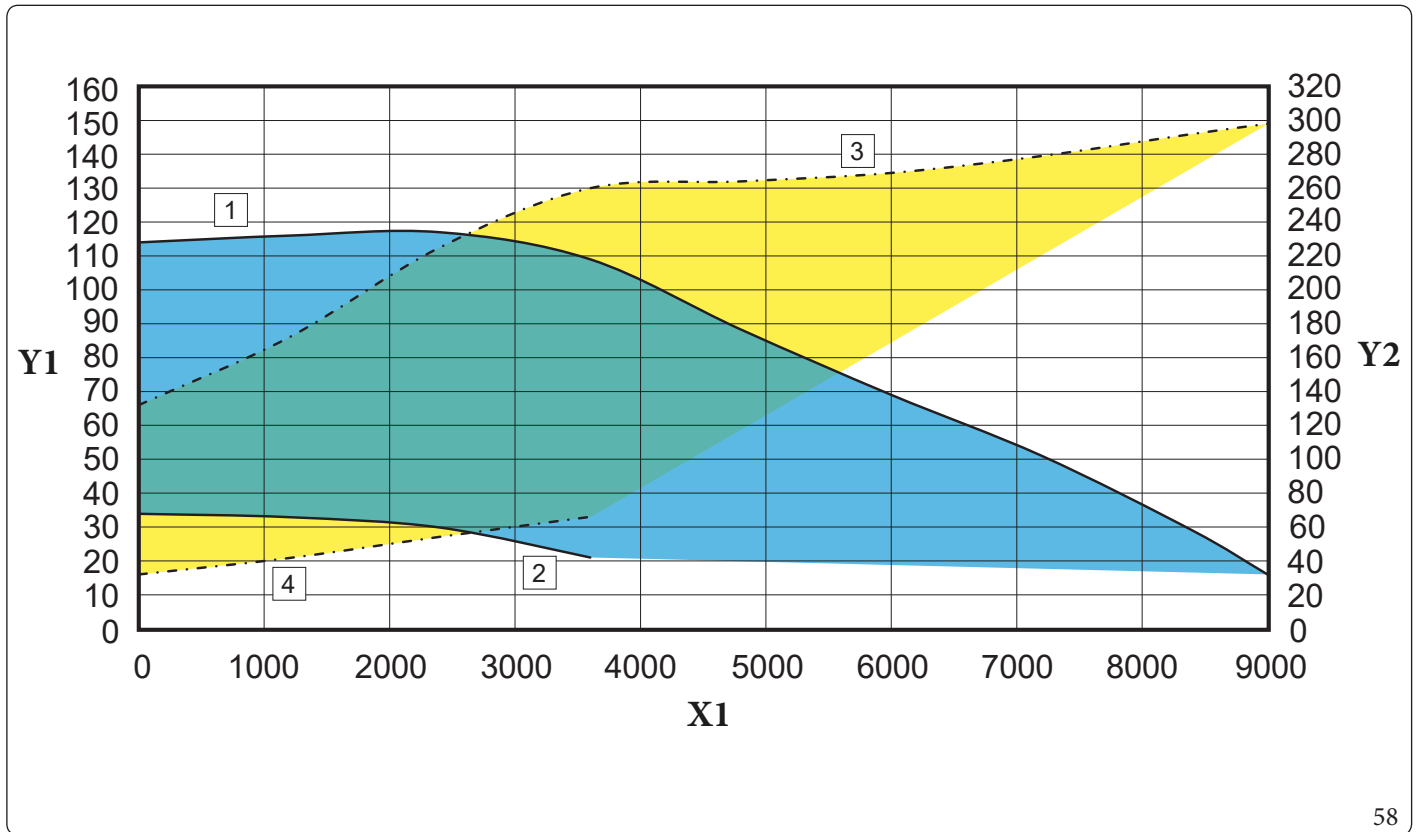

Key (Fig. 58)

- 1 = Head available to the system at 100% speed
- 2 = Head available to the system at 50% speed
- 3 = Pump absorbed power at 100% speed
- 4 = Pump absorbed power at 50% speed

- X1 = Flow rate (l/h)
- Y1 = Head (kPa)
- Y2 = Power absorbed by pump (W)

Area between curves 1 and 2 = Available system head
 Area between curves 3 and 4 = Circulator absorbed power

1.63 KITS AVAILABLE ON REQUEST

A wide range of accessories is available for the Victrix Pro V2 range to meet all different installation needs.



Check the complete list of kits available and which can be combined with the product, consult the Immergas website, the Immergas Price List or the technical-commercial documentation (catalogues and data sheets).



1.64 MAIN COMPONENTS

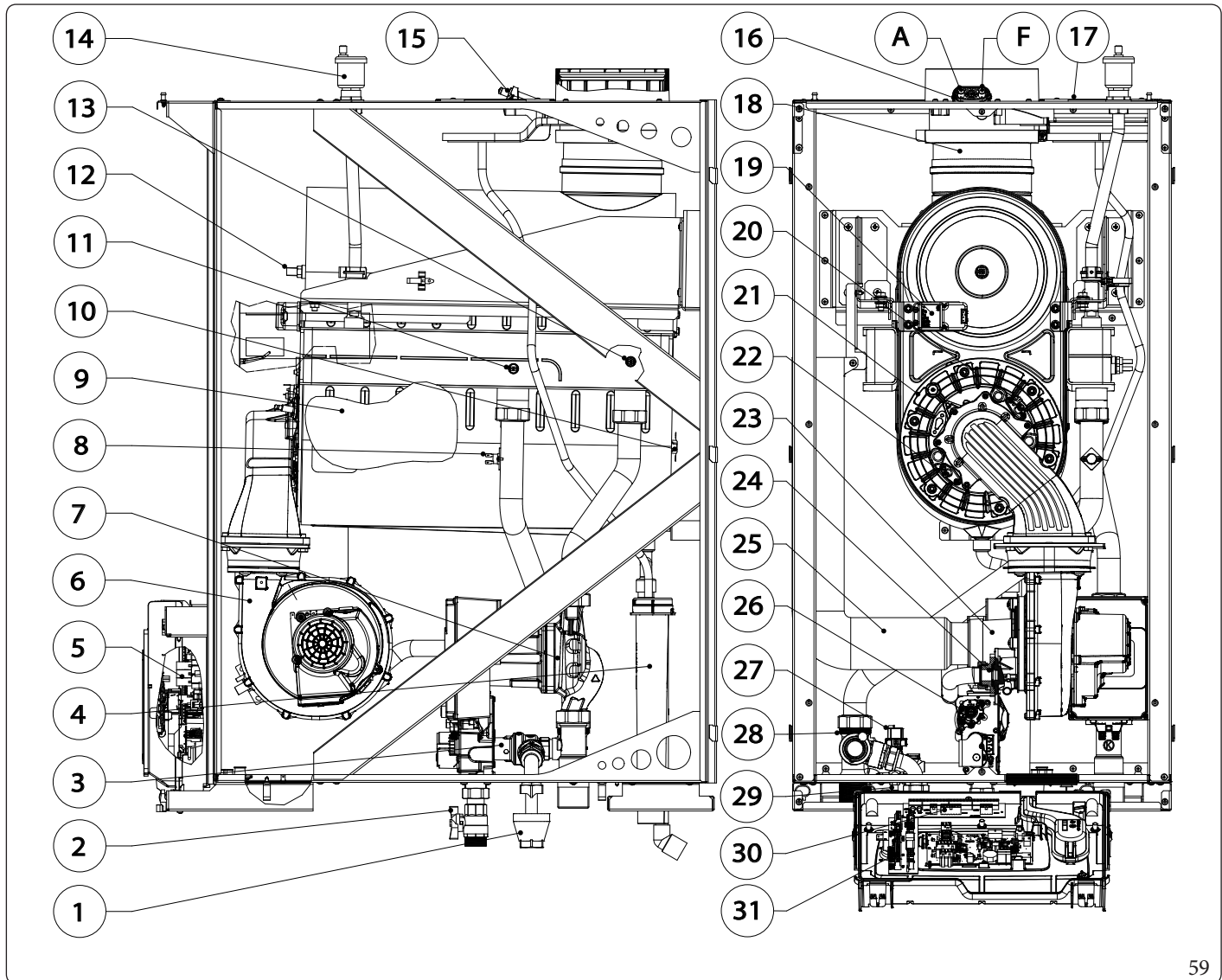

Key (Fig. 59):

- | | | | | | |
|----|---|------------------------------------|----|---|--|
| 1 | - | Tundish | 16 | - | Sample points (air A) - (flue gases F) |
| 2 | - | Gas isolation valve | 17 | - | Intake closing cap Ø 160 |
| 3 | - | INAIL safety valve 5.4 bar | 18 | - | Flange connection module-flue hood |
| 4 | - | Condensate siphon | 19 | - | Igniter |
| 5 | - | P.C.B. | 20 | - | Ignition glow plug |
| 6 | - | Fan | 21 | - | Combustion group |
| 7 | - | Pump | 22 | - | Detection electrode |
| 8 | - | Overheating safety thermostat | 23 | - | Venturi |
| 9 | - | Burner | 24 | - | Gas nozzle |
| 10 | - | Heat exchanger safety thermofuse | 25 | - | Air intake pipe |
| 11 | - | System flow adjustment NTC probe | 26 | - | Gas valve |
| 12 | - | Flue probe with thermofuse | 27 | - | Pressure transducer |
| 13 | - | System return adjustment NTC probe | 28 | - | Flow hydraulic unit |
| 14 | - | Automatic air vent valve | 29 | - | Drain fitting |
| 15 | - | Flange with sample points | 30 | - | Low power connection board |
| | | | 31 | - | High power connection board |

INSTALLER

USER

MAINTENANCE TECHNICIAN

TECHNICAL DATA

59



1.65 HYDRAULIC DIAGRAM WITH OPTIONAL

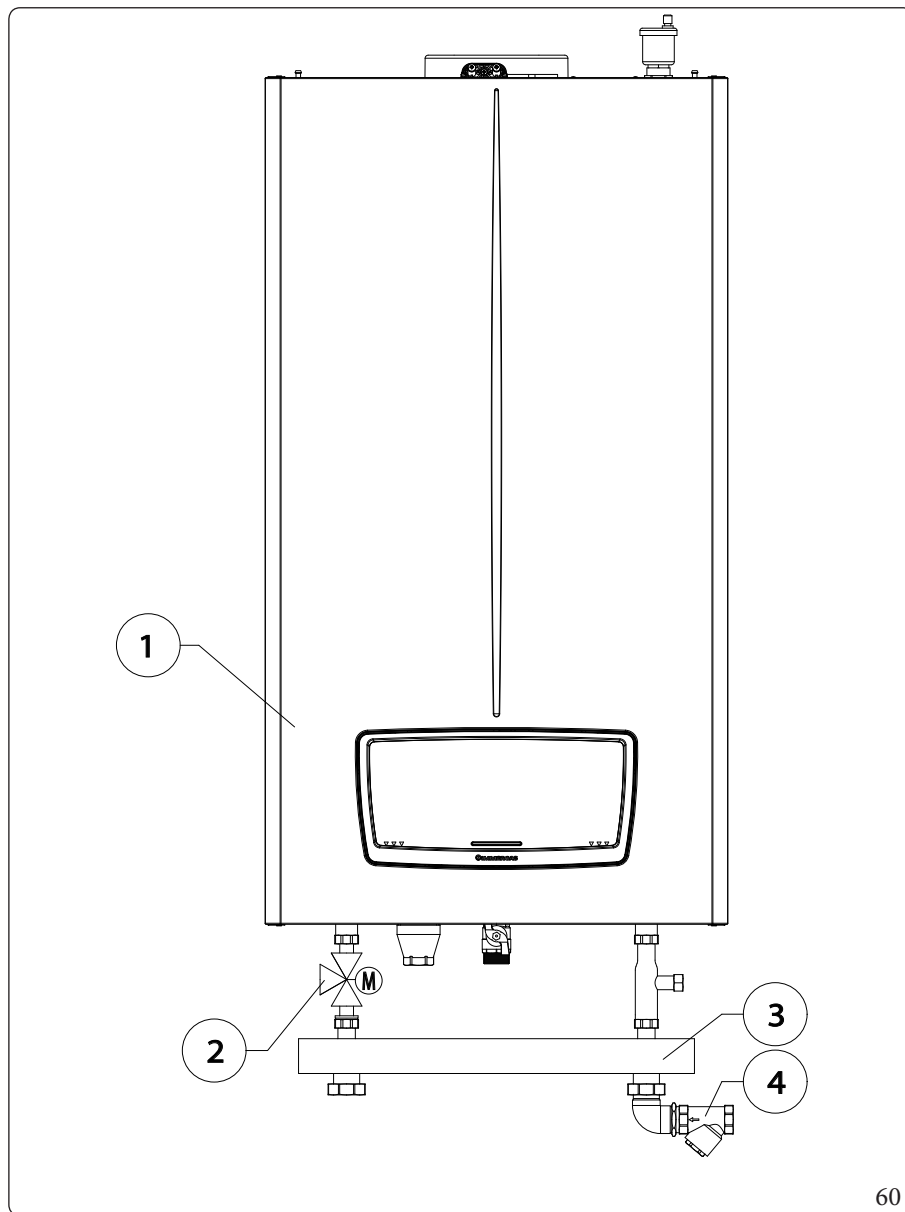

Key (Fig. 60):

- 1 - Generator
- 2 - Storage tank connection 3-way valve
- 3 - Hydraulic/mixing collector
- 4 - Slurry collection brass filter



The boilers must be installed in the configurations and with their own original Immergas cascade and safety kits.

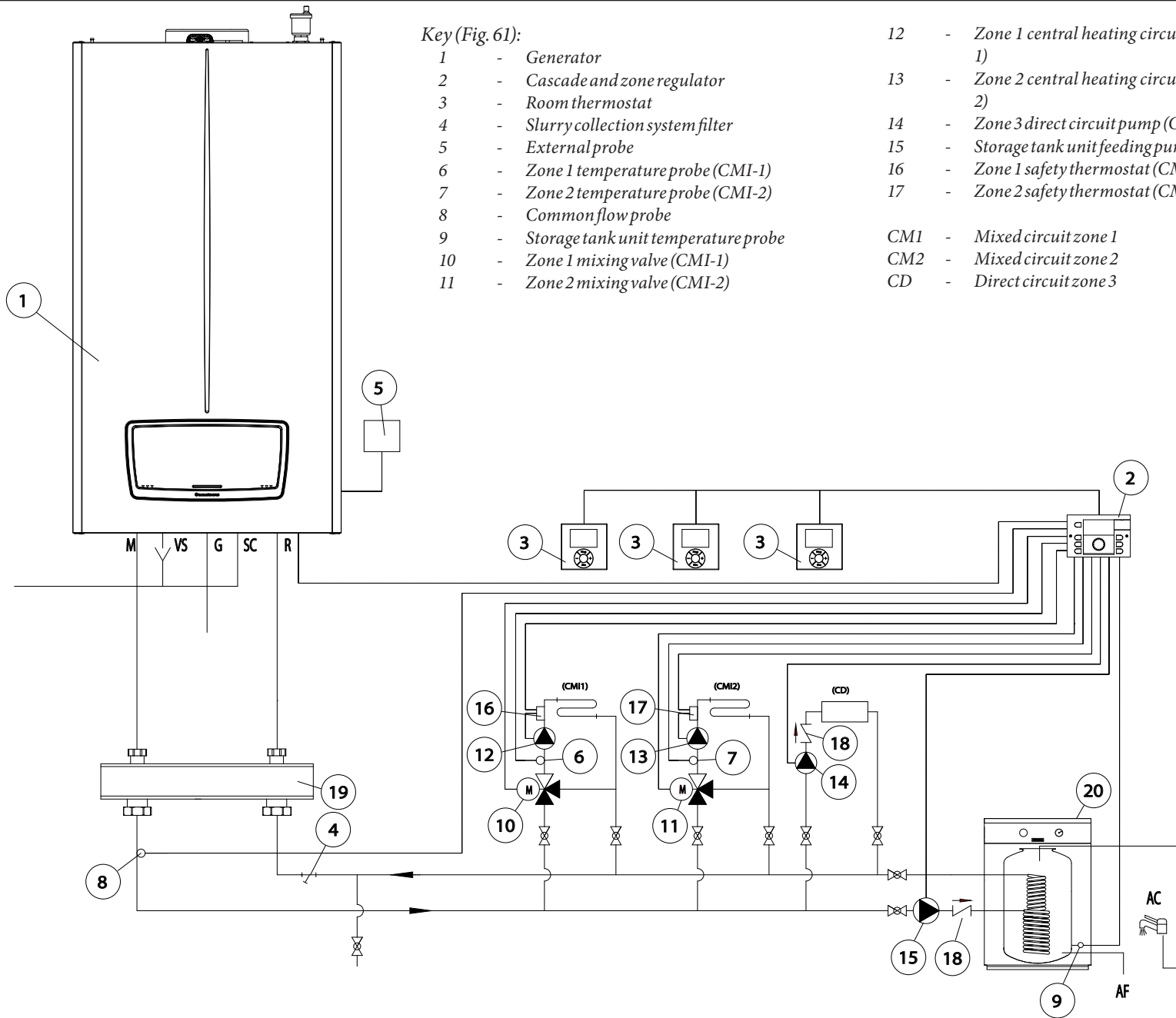

Key (Fig. 61):

- 1 - Generator
- 2 - Cascade and zone regulator
- 3 - Room thermostat
- 4 - Slurry collection system filter
- 5 - External probe
- 6 - Zone 1 temperature probe (CMI-1)
- 7 - Zone 2 temperature probe (CMI-2)
- 8 - Common flow probe
- 9 - Storage tank unit temperature probe
- 10 - Zone 1 mixing valve (CMI-1)
- 11 - Zone 2 mixing valve (CMI-2)
- 12 - Zone 1 central heating circuit pump (CMI-1)
- 13 - Zone 2 central heating circuit pump (CMI-2)
- 14 - Zone 3 direct circuit pump (CD)
- 15 - Storage tank unit feeding pump
- 16 - Zone 1 safety thermostat (CMI-1)
- 17 - Zone 2 safety thermostat (CMI-2)
- CM1 - Mixed circuit zone 1
- CM2 - Mixed circuit zone 2
- CD - Direct circuit zone 3



2 INSTRUCTIONS FOR USE AND MAINTENANCE

2.1 GENERAL RECOMMENDATIONS



Never expose the wall-mounted appliance to direct vapours from a hob.



Access to the heating control unit and therefore use and adjustment of the device is only allowed to individuals envisioned by current law, which are respectively:

- system manager;
- system conductor;
- third manager.



For safety purposes, check that the air intake/flue exhaust terminals (if fitted) are not blocked.



If temporary shutdown of the appliance is required, proceed as follows:

- a) drain the heating system if antifreeze is not used;
- b) shut-off all electrical, water and gas supplies.



In the case of work or maintenance to structures located in the vicinity of ducting or devices for flue extraction and relative accessories, switch off the appliance and on completion of operations ensure that a qualified technician checks efficiency of the ducting or other devices.



Never clean the appliance or connected parts with easily flammable substances.



Do not open or tamper with the appliance.



Never leave containers or flammable substances in the same environment as the appliance.



Do not take apart or tamper with the intake and exhaust pipes.



Only use the user interface devices listed in this section of the booklet.



Do not climb on the appliance, do not use the appliance as a support base.



In the event of malfunctions, faults or incorrect operation, turn the appliance off and contact an authorised company (e.g. the Authorised Technical Assistance Centre, which has specifically trained staff and original spare parts).
Do not attempt to modify or repair the appliance alone.



The use of components involving use of electrical power requires some fundamental rules to be observed such as:

- do not touch the appliance with wet or moist parts of the body; do not touch when barefoot;
- never pull electrical cables or leave the appliance exposed to atmospheric agents (rain, sunlight, etc.);
- the appliance power cable must not be replaced by the user;
- in the event of damage to the power supply cable, switch off the appliance and contact exclusively qualified staff for replacement;
- if the appliance is not to be used for a certain period, disconnect the main appliance external switch.



Water at a temperature of more than 50 °C can cause serious burns.
Always check the water temperature before any use.



The temperatures indicated by the display have a tolerance of +/- 3°C due to environmental conditions that cannot be blamed on the appliance.



If you smell gas in the building:

- close the gas meter interception device or the main interception device;
- if possible, close the gas interception valve on the product;
- if possible, open doors and windows wide and create an air current;
- do not use open flames (e.g. lighters, matches);
- do not smoke;
- do not use electrical switches, plugs, door bells, telephones or intercom devices in the building;
- call an authorised company (e.g. Authorised Technical Assistance Centre).



if you smell burning or see smoke coming out of the appliance, switch it off, disconnect power, close the main gas isolation valve, open the windows and call an authorised company (e.g. Authorised Technical Assistance Centre).



At the end of its service life, the appliance must not be disposed of like normal household waste nor abandoned in the environment, but must be removed by a professionally authorised company as required by current legislation.
Contact the manufacturer for disposal instructions.



2.2 CLEANING AND MAINTENANCE



To preserve the appliance's integrity and keep the safety features, performance and reliability, which distinguish it, unchanged over time, you must execute maintenance operations on a yearly basis in compliance with what is stated in the relative point at "annual check and maintenance of the appliance", in compliance with national, regional, or local standards in force.

2.3 AERATION AND VENTILATION OF THE INSTALLATION ROOMS

See chapter "1.7 Aeration and Ventilation of the installation rooms" of this booklet.

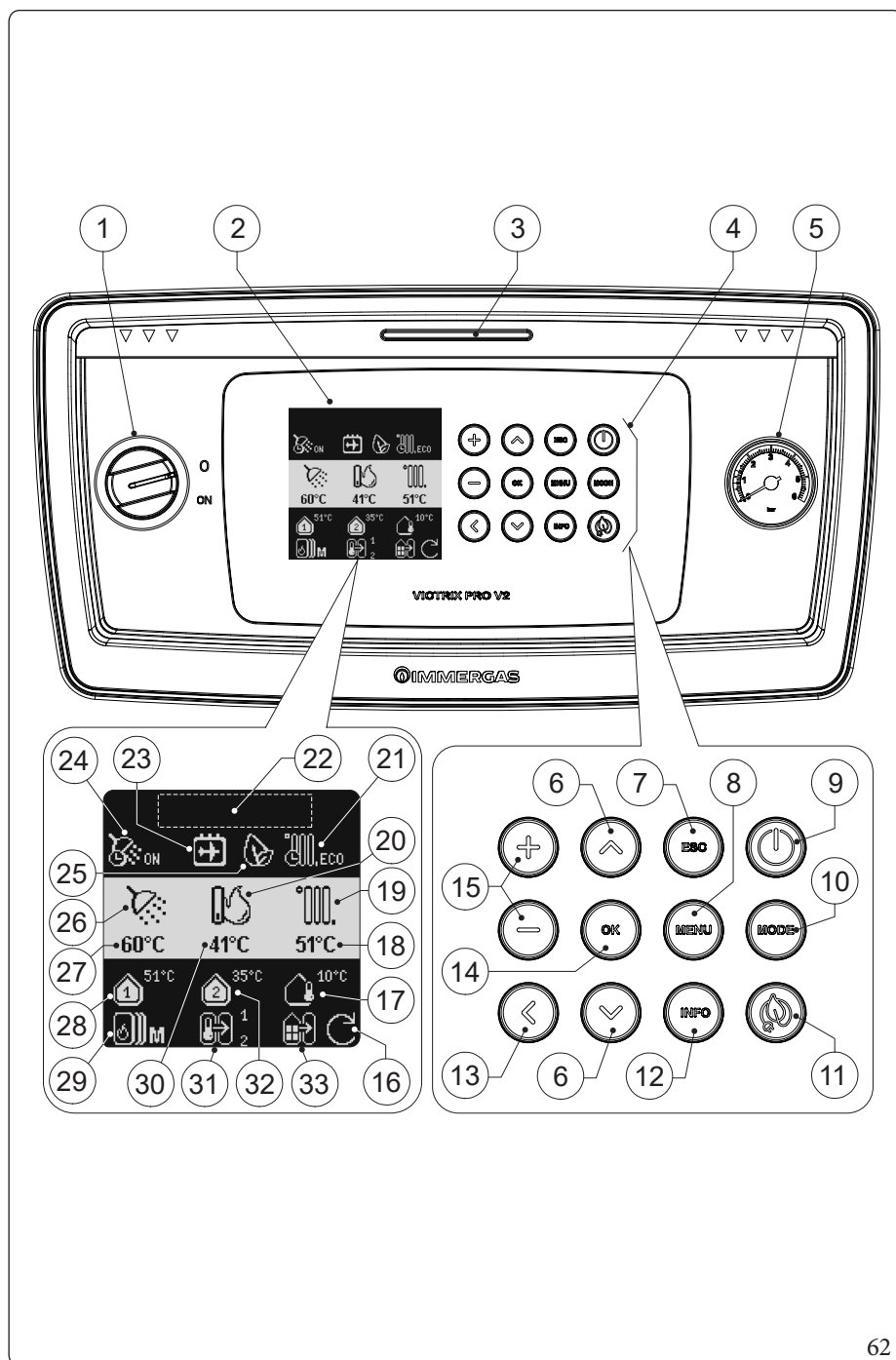

Key (Fig. 62):

- 1 - Main switch
- 2 - Multifunction display (main screen)
- 3 - Sliding door
- 4 - Function keys
- 5 - Instrument pressure gauge
- 6 - Menu scroll buttons
- 7 - Return to main screen button
- 8 - Menu button. Used to allow access to the User and Installer menu
- 9 - Standby button. Used to put the boiler in standby mode; press approx. 3 seconds to change the operating state.
- 10 - Mode button. Used to enable/disable central heating and/or DHW sequentially; press approx. 1 second to change operating status.
- 11 - Eco button. Used to manually enable the Eco function; press approx. 1 second to change the operating state.
- 12 - Info button. Used to display diagnostic elements directly
- 13 - Back function button
- 14 - OK button
- 15 - Increases and decreases the selected value
- 16 - Active when updating parameters
- 17 - Active when external probe connected
- 18 - Indicates the central heating setpoint temperature
- 19 - Central heating mode enabled
- 20 - Indicates the presence of flame and its power level
- 21 - Hourly heating programming active
- 22 - Active mode (ON, OFF, ECO) of central heating schedule
- 23 - Indicates date and time or alarm with error
- 24 - Active holiday mode
- 25 - Hourly programming of active DHW
- 26 - Active mode (ON, OFF, ECO) of DHW schedule
- 27 - Active when ECO mode is manually activated
- 28 - DHW mode enabled
- 29 - Indicates the DHW setpoint with probe
- 30 - Icon and setpoint Zone 1
- 31 - Indicates the presence of the simple cascade
- 32 - Indicates the role of the boiler in the simple cascade
- 33 - Boiler flow temperature

2.5 USING THE APPLIANCE



Before ignition, make sure that the system is full of water, checking that the pressure gauge (Fig. 62) indicates a base value at which the system has been designed and calculated and however not less than 0.5 bar.

- Open the gas isolation valve upstream from the appliance.
- Turn the main switch for the appliance to run a self-diagnosis test. It will then go back to the status it was in prior to being switched off.

Display when the appliance is switched on

The following are displayed upon ignition:

- Panel firmware version;
- Board firmware version.

Display operation

Below is a description of how to use the control panel, including:

- Enter the menus;
- Moving in the menus;
- Set a menu item;
- Confirming a change;
- Exit without saving.



When you enter 'User menu', a list of menus appears; using the directional buttons '↖' and '↘', you can scroll through the list. When the downward-pointing arrow is present (Fig. 63), this means that the menu continues (Fig. 64).

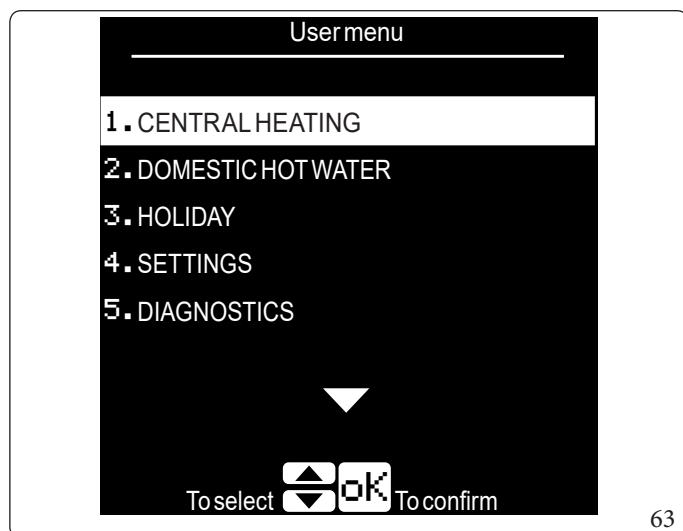

63

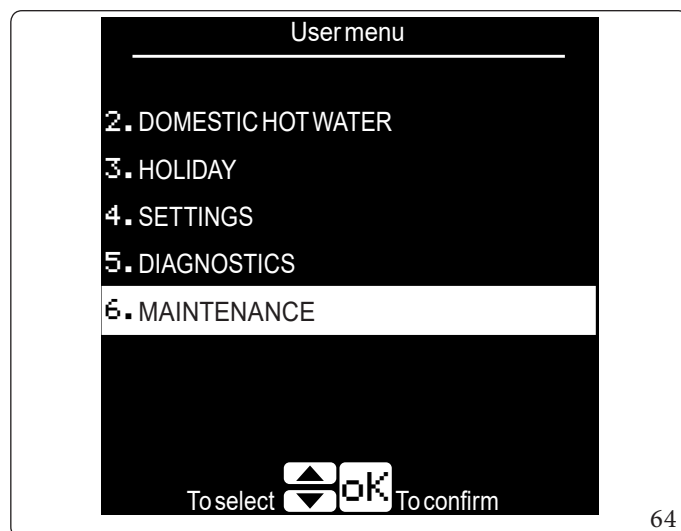

64



When you enter the functions and no data appears next to the item, this means that a submenu is present (Fig. 65); by selecting the line using the directional buttons '↖' and '↘' and then pressing the 'OK' button, you access this submenu (Fig. 66).

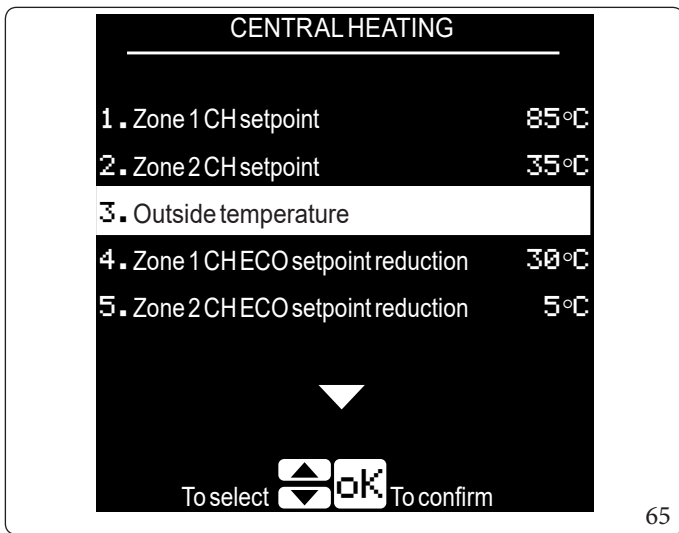

65

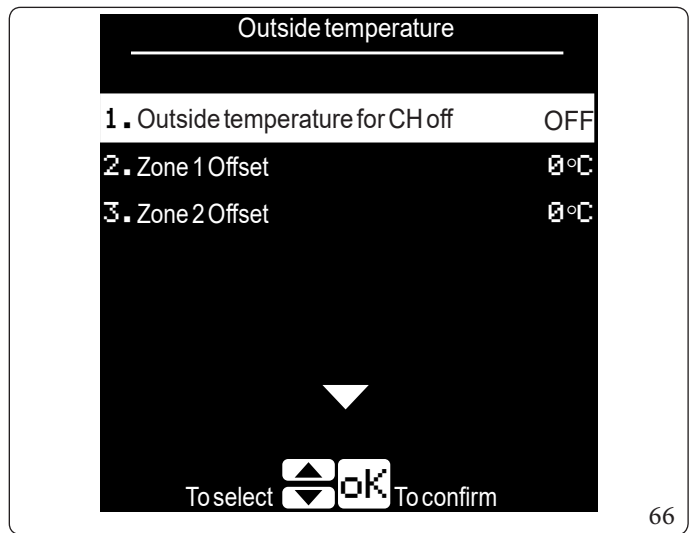

66



If the descriptive text on the display is not fully visible, it will automatically scroll to the left to allow it to be read completely.

- **Enter the menus**

The control panel menus can be accessed by pressing the buttons (Fig. 62):

- "Menu" to enter the general User/Technical menu;
- "Info" to enter the general information menu (Diagnostics);

- **Moving in the menus**

To scroll through the menu items, simply press the directional buttons "↗" and "↘".

Some menus are excessively long, but they scroll automatically so that they can be read completely.

To return to the previous menu, press '⏪'.

To return directly to the main menu instead, press the 'ESC' button.

- **Set menu item**

Go to the menu item to be set following the instructions given previously.

When you reach the menu item you want to set, press 'OK', the value on the right next to the description will be highlighted.

Press the '+' or '-' button to adjust the value.

- **Confirming a change**

When you have finished editing, press 'OK' to confirm the change.

- **Exit without saving**

If at the end of the modification you press "⏪", you will return to the previously selected menu item without confirming the modification.



In any case, to return to the main screen without saving, simply press the 'ESC' key.



2.6 WEEKLY SCHEDULE

Time programming allows you to define the operating times of the device.



Two independent programmes are available, one for CH and one for DHW.

To activate programming, you must enter the menus "CENTRAL HEATING" and "DOMESTIC HOT WATER" and under the parameter "Enable/disable scheduler" schedule, select "Enabled" with the OK button.

Three operating states are selectable:

- ON: indicates the comfort operating range;
- ECO: indicates the operating eco band (at reduced setpoint);
- OFF function disabled.



The unscheduled band is understood as ON: (leaving more programmable bands available for OFF and ECO).



The status of the schedule is visible on the display (main screen).



Two functions are available during hourly programming, 'Copy to the Next Day' and 'Save & Exit'. With the OK button, you can directly select 'Save & Exit', to select 'Copy to the Next Day', press the  button.



For this function to work properly, make sure that the date and time have been set correctly. In the event of a power failure, the time and date are guaranteed for about 8 hours (subject to continuous power supply for at least 24 hours), after which they are no longer guaranteed.

Setpoints used in central heating

In the "ON" band, the reference setpoints are the two parameters "Zone 1 CH setpoint" and "Zone 2 CH setpoint" according to the system configuration.

In the "ECO" band, the reference setpoint is given by the parameters of the "ON" band, from which "Zone 1 CH ECO setpoint reduction" and "Zone 2 CH ECO setpoint reduction" must be subtracted according to the system configuration (for further clarification, see Parag. 1.13).

Setpoints used in DHW

In the "ON" band, the reference setpoint is given by the parameter "DHW setpoint".

In the "ECO" band, the reference setpoint is given by the ON band parameter from which "ECO setpoint reduction" must be subtracted (consequently, the flow temperature value is also lowered).

2.7 ECO

The function "ECO" is used to reduce the operating setpoint.

The function "ECO" is activated by a direct button (Control Panel) or by the schedule (Parag. 2.6).

The manual "ECO" function reduces setpoint CH and DHW.



The function "ECO" in DHW operation is not active with a DHW thermostat.



The manual "ECO" function has priority over the ECO function activated by the schedule.



The "ECO" function has lower priority than the Holiday function.
"ECO" mode does not apply in the case of external heating requests (BUS).



The parameters of the "ECO" function in CH are as follows:

- Zone 1 CHECO setpoint reduction;
- Zone 2 CHECO setpoint reduction;
- ECO shutdown hysteresis CH Zone 1;
- ECO shutdown hysteresis CH Zone 2.

The parameter for the function "ECO" in DHW is as follows:

- ECO setpoint reduction.



If parameters "ECO shutdown hysteresis CH Zone 1" and "ECO shutdown hysteresis CH Zone 2" are set other than 0, "CH Demand" is inhibited when the calculated setpoint is lower than the temperature set on parameter "Zone 1 minimum CH setpoint" and "Zone 2 minimum CH setpoint" (the two zones are independent).

The request is allowed again when the calculated setpoint increases by the value as per parameter "ECO shutdown hysteresis CH Zone 1"/"ECO shutdown hysteresis CH Zone 2".

2.8 HOLIDAYS

The function "HOLIDAY" is used to programme a period of time, with a setpoint specified by parameter.

The holiday function can be activated alternatively in the following way:

- manually from the menu, by setting the parameter "Manual holiday mode" to "ON" (see main screen, in the Control Panel section): to deactivate the function, set the same parameter to "OFF";
- by setting the holiday period from the menu, via the parameter "Set holiday period": by pressing the "OK" button on the parameter, the holiday start date is proposed and after confirmation, the holiday end date.



The function is activated at 00:00 on the day the holiday starts and is deactivated at midnight on the day the holiday ends.



The active "Holiday mode" will only be visible on the main screen during the set period (Control Panel).



For this function to work properly, make sure that the date and time have been set correctly. In the event of a power failure, the time and date are guaranteed for about 8 hours (subject to continuous power supply for at least 24 hours), after which they are no longer guaranteed.



The "Holiday mode" in DHW operation is not active with a DHW thermostat.



The "Holiday mode" has higher priority than the "ECO" function.

The parameters of "Holiday mode" in CH are as follows:

- Zone 1 CH holiday setpoint;
- Zone 2 CH holiday setpoint.

The parameter of "Holiday mode" in DHW is as follows:

- DHW holiday setpoint.



The "Zone 1 CH holiday setpoint/Zone 2 CH holiday setpoint" that can be set during the holiday is limited by the value indicated in the respective parameter "Zone 1 CH setpoint/Zone 2 CH setpoint".



2.9 USER MENU

Press the "MENU" button to access a list of variables that enable you to customise use of the system. Hereunder is a list of all available menus:

MENU		
	Menu item	Description
1.	USER	Allows selection of the user menu
2.	TECHNICIAN	Allows selection of the technical menu (access allowed via password for Service only)

USERMENU	
1.	CENTRALHEATING
2.	DOMESTICHOTWATER
3.	HOLIDAY
4.	SETTINGS
5.	DIAGNOSTICS
6.	MAINTENANCE



The "Restore settings" column in the following tables represents the parameters that can be reset to default values or another value (indicated in the column itself) by means of a specific item in Technician menu, by the Maintenance technician. For simple cascade, please refer to the cascade booklet.

USERMENU/CENTRALHEATING						
	Menu item	Description	Range	Default	Restore settings	Customised value
1.	Zone 1 CH setpoint	Set the "Zone 1 CH setpoint" (user setpoint). Please note that this parameter can change the parameter "Zone 1 CH holiday setpoint".	Zone 1 minimum CH setpoint ÷ Zone 1 maximum CH setpoint	85 (°C)	Yes	
2.	Zone 2 CH setpoint	Set the "Zone 2 CH setpoint" (user setpoint). Please note that this parameter can change the parameter "Zone 2 CH holiday setpoint".	Zone 2 minimum CH setpoint ÷ Zone 2 maximum CH setpoint	35 (°C)	Yes	
3.	Outdoor temperature	See table following this one.	-	-	-	



Menu item		Description	Range	Default	Restore settings	Customised value
4.	Zone 1 CH ECO setpoint reduction	Sets the temperature that will be subtracted from the actual setpoint for heating zone 1 when the "ECO" mode is activated. If the parameter "CH Request type" is set to "Only OTC", it defines the level for the reduction of the control setpoint for zone 1 heating, if the room thermostat is closed.	0 ÷ 50 (°C)	30 (°C)	Yes	
5.	Zone 2 CH ECO setpoint reduction	Sets the temperature that will be subtracted from the actual setpoint for heating zone 2 when the "ECO" mode is activated. If the parameter "CH Request type" is set to "Only OTC", it defines the level for the reduction of the control setpoint for zone 2 central heating, if the room thermostat is closed.	0 ÷ 80 (°C)	5 (°C)	Yes	
6.	Zone 1 CH constant setpoint reduction	Defines the level for reducing the control setpoint for zone 1 heating when the room thermostat contact is open. It only applies if the CH demand type parameter is set as a constant setpoint.	0 ÷ 50 (°C)	0 (°C)	Yes	
7.	Zone 2 CH constant setpoint reduction	Defines the level for reducing the control setpoint for zone 2 heating when the room thermostat contact is open. It only applies if the CH demand type parameter is set as a constant setpoint.	0 ÷ 50 (°C)	0 (°C)	Yes	
8.	Enable/disable scheduler	Depending on the selection, it is possible to enable/disable the CH Demand from daily/weekly programming.	Disabled ÷ Enabled	Disabled	Yes	
9.	Scheduler set	Allows you to set daily programming, or by periods (Monday-Friday) - (Monday-Sunday) - (Saturday-Sunday) central heating activation time slots. A maximum of six time slots are allowed per day/period.	-	-	No	

USER MENU/CENTRAL HEATING/OUTDOOR TEMPERATURE

Menu item		Description	Range	Default	Restore settings	Customised value
1.	Outside temperature for CH off	Defines the outside temperature at which the central heating demand is disabled.	7 ÷ 25 (°C)	OFF	Yes	
2.	Zone 1 Offset	This is the offset value to be added on zone 1 to the setpoint calculated from the OTC curve.	-15 ÷ 15 (°C)	0 (°C)	Yes	
3.	Zone 2 Offset	This is the offset value to be added on zone 2 to the setpoint calculated from the OTC curve.	-15 ÷ 15 (°C)	0 (°C)	Yes	

INSTALLER

USER

MAINTENANCE TECHNICIAN

TECHNICAL DATA



When Thermostat is set in Technician menu/HYDRAULIC SETTINGS/DHW request type, the table below will look like this:

USERMENU/DOMESTIC HOT WATER						
Menu item		Description	Range	Default	Restore settings	Customised value
1.	DHW setpoint	Sets the domestic hot water setpoint (can only be changed via access "Technician menu").	35 ÷ 87 (°C)	80 (°C)	Yes	
2.	Enable/disable scheduler	Depending on the selection, it is possible to enable/disable the DHW Demand from daily/weekly programming.	Disabled ÷ Enabled	Disabled	Yes	
3.	Scheduler set	Allows you to set daily programming, or by periods (Monday-Friday) - (Monday-Sunday) - (Saturday-Sunday) Domestic hot water activation time slots. A maximum of 6 time slots are allowed per day/period.	-	-	No	

When Sensor is set in Technician menu/HYDRAULIC SETTINGS/DHW request type, the table below will look like this:

USERMENU/DOMESTIC HOT WATER						
Menu item		Description	Range	Default	Restore settings	Customised value
1.	DHW setpoint	Sets the domestic hot water setpoint (User setpoint).	20 ÷ 87 (°C)	65 (°C)	Yes	
2.	ECO setpoint reduction	Sets the temperature that will be subtracted from "DHW setpoint" when the "ECO" mode is activated.	0 ÷ 50 (°C)	20 (°C)	Yes	
3.	Enable/disable scheduler	Depending on the selection, it is possible to enable/disable the DHW Demand from daily/weekly programming.	Disabled ÷ Enabled	Disabled	Yes	
4.	Scheduler set	Allows you to set daily programming, or by periods (Monday-Friday) - (Monday-Sunday) - (Saturday-Sunday) Domestic hot water activation time slots. A maximum of 6 time slots are allowed per day/period.	-	-	No	



When Thermostat is set in Technician menu/HYDRAULIC SETTINGS/DHW request type, the table below will look like this:

USER MENU/HOLIDAY/HOLIDAY MODE						
Menu item		Description	Range	Default	Restore settings	Customised value
1.	Zone 1 CH holiday setpoint	Sets the zone 1 heating setpoint when "Holiday mode" is active If the parameter "Zone 1 CH setpoint" is set to a lower value than the parameter "Zone 1 CH holiday setpoint", the latter will assume the same value as set on the parameter "Holiday mode" (this happens when storing).	Zone 1 minimum CH setpoint ÷ Zone 1 CH setpoint (°C)	55 (°C)	Yes	
2.	Zone 2 CH holiday setpoint	Sets the zone 2 heating setpoint when "Holiday mode" is active If the parameter "Zone 2 CH setpoint" is set to a lower value than the parameter "Zone 2 CH holiday setpoint", the latter will assume the same value as set on the parameter "Holiday mode" (this happens when storing).	Zone 2 minimum CH setpoint ÷ Zone 2 CH setpoint (°C)	20 (°C)	Yes	
3.	Set holiday period	When selected, a new screen will open to sequentially set the start and end date of "Holiday mode". This function is an alternative to the parameter "Manual holiday mode".	Holiday start ÷ Holiday end	-	No	
4.	Manual holiday mode	Allows the manual activation of "Holiday mode", which remains active until manually deactivated. When set to 'ON', this parameter has priority over the previous parameter 'Set holiday period'. This function is an alternative to the parameter "Set holiday period".	ON ÷ OFF	OFF	Yes	

INSTALLER

USER

MAINTENANCE TECHNICIAN

TECHNICAL DATA



When Sensor is set in Technician menu/HYDRAULIC SETTINGS/DHW request type, the table below will look like this:

USER MENU/HOLIDAY/HOLIDAY MODE						
Menu item	Description	Range	Default	Restore settings	Customised value	
1.	Zone 1 CH holiday setpoint	Sets the zone 1 heating setpoint when "Holiday mode" is active. If the parameter "Zone 1 CH setpoint" is set to a lower value than the parameter "Zone 1 CH holiday setpoint", the latter will assume the same value as set on the parameter "Zone 1 CH setpoint" (this happens when storing).	Zone 1 minimum CH setpoint ÷ Zone 1 CH setpoint (°C)	55 (°C)	Yes	
2.	Zone 2 CH holiday setpoint	Sets the zone 2 heating setpoint when "Holiday mode" is active. If the parameter "Zone 2 CH setpoint" is set to a lower value than the parameter "Zone 2 CH holiday setpoint", the latter will assume the same value as set on the parameter "Zone 2 CH setpoint" (this happens when storing).	Zone 2 minimum CH setpoint ÷ Zone 2 CH setpoint (°C)	20 (°C)	Yes	
3.	DHW holiday setpoint	Sets the DHW setpoint when "Holiday mode" is active. If the parameter "Storage temperature setpoint" is set to a lower value than the parameter "DHW holiday setpoint", the latter will assume the same value as set on the parameter "Storage temperature setpoint" (this happens when storing).	20 ÷ 87 (°C)	45 (°C)	Yes	
4.	Set holiday period	When selected, a new screen will open to sequentially set the start and end date of "Holiday mode". This function is an alternative to the parameter "Manual holiday mode".	Holiday start ÷ Holiday end	-	No	
5.	Manual holiday mode	Allows the manual activation of "Holiday mode", which remains active until manually deactivated. When set to 'ON', this parameter has priority over the previous parameter 'Set holiday period'. This function is an alternative to the parameter "Set holiday period".	ON ÷ OFF	OFF	Yes	

USER MENU/SETTINGS/USER INTERFACE

Menu item	Description	Range	Default	Restore settings	Synchronisation Slave	Customised value
1. Select language	Allows the selection of the desired language.	English Italian Bulgarian Czech Greek French Flemish Polish Portuguese Slovak Spanish Romanian Russian Slovenian German Turkish Ukrainian Hungarian	English	No	-	
2. Measurement units	Allows selection of the unit of measurement of the quantities.	Imperial ÷ Metric	Metric	No	-	
3. Set date	Allows the date to be set.			No	-	
4. Set time	Allows setting the format and then the time.	24h clock format ÷ 12h clock format	24h clock format	No	-	
5. Standby backlight	Standby backlight level. Add text warning: 'keep backlight level below 30% to reduce display degradation'.	30 ÷ 100 (%)	30 (%)	No	No	
6. Active backlight	Active backlight level.	30 ÷ 100 (%)	100 (%)	No	No	
7. Display contrast	Defines the contrast of the LCD panel.	0 ÷ 511	*	No	No	

* The value varies for each display (pre-set by the board manufacturer). The typical average value is 310.

USER MENU/DIAGNOSTICS

Menu item	Description
1. Boiler state	A new screen with the current operating status of the device will open.
2. System information	Shows a list of information about the installation.
3. Lockout history	It shows the last eight errors. Pressing the 'OK' button on the highlighted error will open a new screen containing details on the status of the device at the time the error occurred.
4. Boiler statistics	Shows a list of statistics
5. Firmware release	Shows which firmware version is currently installed on the boards.



The Diagnostics menu can also be accessed directly via the 'INFO' button.

INSTALLER

USER

MAINTENANCE TECHNICIAN

TECHNICAL DATA



USER MENU/DIAGNOSTICS/BOILER STATE	
Menu item	Description
Parameters loading	Each time that the parameters are loaded from the P.C.B. to the display board.
Deaeration	Displayed when the deaeration function is active or waiting to be activated.
Slave operation	Displayed in simple cascade mode (only on slave boilers).
DHW Postpump	Displayed at the end of "DHW Demand" and during the pump post-circulation phase.
Antifreeze protection	Displayed when Antifreeze mode is active.
CH Postpump	Displayed at the end of "CH Demand" and during the pump post-circulation phase.
DHW Demand	Displayed when "DHW Demand" is active.
Request Antilegionella	Displayed when the "Antilegionella" request is active.
CH/DHW Demand	Displayed when parameter "Parallel mode" is active and "CH Demand" and "DHW Demand" are active at the same time.
CH Demand	Displayed when "CH Demand" is active.
CH - Primary circuit setpoint reached	Displayed when the setpoint is reached and the burner is switched off during "CH Demand".
DHW Burner Delay	Displayed with "DHW Demand" the same demand is postponed (this status may not be visible as it is displayed for a few seconds).
DHW - Primary circuit setpoint reached	The burner is switched off due to the flow setpoint being exceeded (displayed for both "DHW Demand" and "CH Demand").
Standby	Displayed when the device is waiting for a request. Displayed on single appliance or Master if in simple cascade.
Chimney sweep demand	Displayed on single appliance or Master if in simple cascade when "Chimney sweep" is activated.
Manual relay test	Displayed when "Manual relay test" is active.

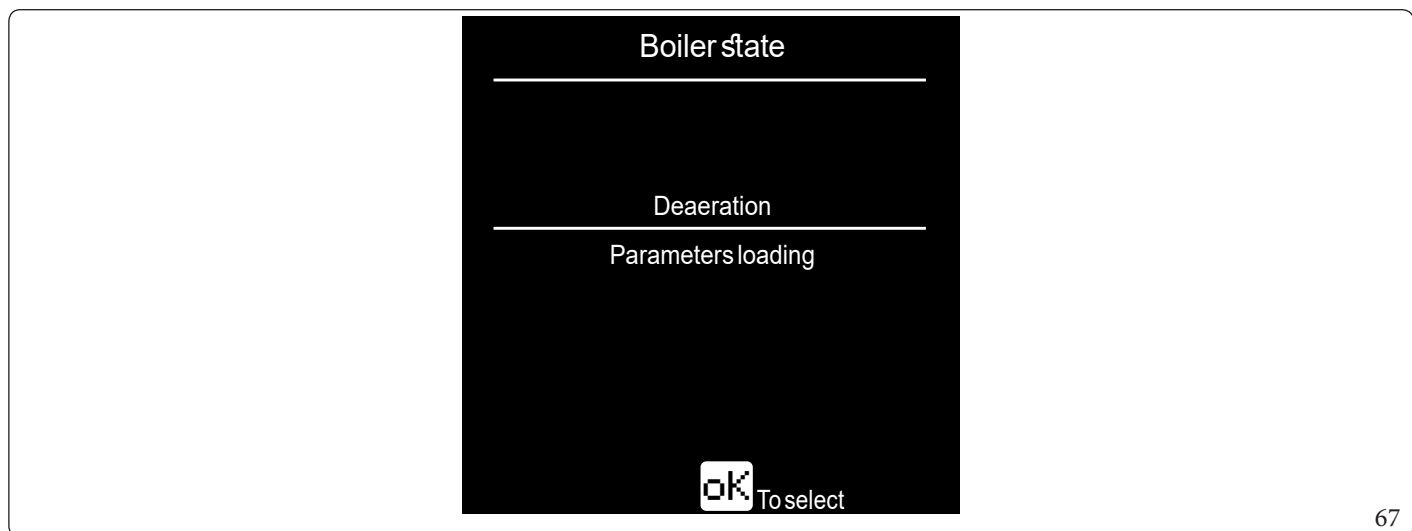

67



Two lines will appear in the display (fig. 67) where the top line represents the current boiler status and the bottom line, the temporary status.

USER MENU/DIAGNOSTICS/SYSTEM INFORMATION

Menu item	Description
1.	Flame current* Value in μ A.
2.	Actual fan speed Real-time fan speed (rpm).
3.	Requested fan speed Fan setpoint (rpm).
4.	Modulation level* Effective burner output value (%).
5.	Boiler setpoint* Temperature value calculated by the system ($^{\circ}$ C).
6.	CH setpoint Required temperature value during heating ($^{\circ}$ C).
7.	Boiler DHW setpoint Required temperature value in DHW phase ($^{\circ}$ C).
8.	Boiler supply temperature Temperature value measured by the system flow regulation probe ($^{\circ}$ C).
9.	Return temperature* Temperature value measured by the system return control probe ($^{\circ}$ C).
10.	Flue temperature* Temperature value measured by the flue probe ($^{\circ}$ C).
11.	Flue temperature threshold Error intervention threshold when the value detected by the flue probe is exceeded (High Flue Temp limit) (Error code 84).
12.	Outdoor temperature* Temperature value measured by the external probe ($^{\circ}$ C).
13.	DHW storage temperature* Temperature value measured by the DHW probe ($^{\circ}$ C).
14.	System temperature* Temperature value measured by the system-side flow sensor ($^{\circ}$ C).
15.	Mix zone temperature* Temperature value measured by the low temperature flow probe ($^{\circ}$ C).
16.	Mix zone setpoint Required temperature value for the low-temperature zone ($^{\circ}$ C).
17.	Water pressure* Pressure value measured by the pressure transducer (bar).
18.	Pump speed Real-time pump speed (%).
19.	Pump feedback Pump status (%).
20.	Number of burners Number of appliances present (1 = single boiler; >1 = number of appliances connected in simple cascade).
21.	Cascade role Role of the appliance in the simple cascade (Master if single appliance or if simple cascade Master boiler, Slave if simple cascade Slave appliance followed by the number assigned during cascade configuration).
22.	Number of burners ON Number of burners on.
23.	Cascade modulation level Effective power value of the simple cascade (%).
24.	Input 0-10V Voltage value at the 0-10V input.

* These parameters have a submenu (chart) accessible by pressing the 'OK' button. The chart shows the last 24 hours measured at 12-minute intervals (119 readings). To view these readings, use the menu scroll buttons (Fig. 62).

INSTALLER

USER

MAINTENANCE TECHNICIAN

TECHNICAL DATA



USER MENU/DIAGNOSTICS/LOCKOUT HISTORY

Shows the list of the last 8 errors. Pressing OK on the highlighted error will open a new screen containing details on the status of the device at the time the error was found (for details on errors, see parag. 2.10).

USER MENU/DIAGNOSTICS/BOILER STATISTICS

	Menu item	Description
1.	CH ignitions*	Number of burner ignitions in "CH mode".
2.	CH runtime	Total hours of burner on in "CH mode".
3.	DHW ignitions*	Number of burner ignitions in "DHW mode".
4.	DHW runtime	Total hours of burner on in "DHW mode".
5.	Total hours power ON	Total hours of boiler power supply (not burner ignition hours).

*When 'I' is detected, this means that the ignitions have reached 20, '2' 40 and so progressively every 20 ignitions.

USER MENU/DIAGNOSTICS/FIRMWARE RELEASE

	Menu item	Description
1.	Display	Views the display board firmware version.
2.	Main board	Displays the P.C.B. firmware version.

USER MENU/MAINTENANCE

	Menu item	Description
1.	Service information	Displays the telephone number of the service centre.
2.	Service due date	Date of next maintenance (see error code 102).



2.10 FAULT AND ANOMALY SIGNALS

The appliance signals any malfunction by means of a numerical code and description on the multifunction display.

From this screen you can:

- Reset the current error (if the error is resettable) by pressing the 'OK' button;
- if the ESC key is pressed, the main screen appears and the error will appear at the top of the display in place of the date and time; pressing 'OK' in this case, the screen is displayed again (with the possibility of resetting the error);
- use the 'MENU' button, but the 'Standby', 'MODE', 'INFO' buttons cannot be used.



In the case of simple cascade, the error display is present on the Master appliance even if caused by the Slave appliance, while in the error history, each appliance records its own errors.

Error Code	Anomaly signalled	Cause	Appliance status / Solution
01	Failed Ignition	In the event of space heating or domestic hot water production demand, the appliance does not switch on within the preset time. Upon appliance commissioning or after extended downtime, it may be necessary to eliminate the block.	Press the OK (Reset) button (1)
02	False Flame	This occurs during the power-on phase in the event of a leak on the detection circuit or anomaly in the flame control unit.	Press the OK (Reset) button (1)
03	Overtemperature	During normal operation, if a fault causes excessive overheating internally, the appliance goes into overheating block.	Press the OK (Reset) button (1)
05	Fan Speed	This occurs if the fan speed is incorrect.	Press the OK (Reset) button (1)
08	Flame circuit fault	During the ignition phase an anomaly was detected on the electronic flame control circuit and the appliance switches off.	Press the OK (Reset) button (1)
09	Gas valve circuit fault	The board detects an anomaly in the gas valve circuit. Before replacing the board, verify the absence of short circuits on gas valve and related connector.	Press the OK (Reset) button (1)
13	Reset limit reached	Number of allowed resets already performed.	Attention: it is possible to reset the anomaly up to 5 consecutive times within 15 minutes. (1) By switching the appliance on and off the 5 attempts are re-acquired.
19	Loss of flame	It occurs when the appliance is correctly ignited but an unexpected extinguishing of the burner flame occurs 8 times in 15 minutes.	Press the OK (Reset) button (1)
21	Main board fault	An error is detected on the main circuit board and the device does not start.	Probable damage of the main circuit board hardware. Press the OK (Reset) button (1)
25	Main board fault	An error is detected on the main circuit board and the device does not start.	Disconnect and reconnect the power supply to the device. (2) (1)

(1) If the shutdown or fault persists, contact an authorised company (e.g. Authorised After-Sales Technical Assistance Centre).

(2) If normal operating conditions are restored, the appliance re-starts without having to be reset.



Error Code	Anomaly signalled	Cause	Appliance status / Solution
30	Supply sensor shorted	The board detects a short-circuit on the system flow regulation NTC probe.	(2)(1)
31	Supply sensor open	The board detects an open contact on the system flow regulation NTC probe.	(2)(1)
32	DHW sensor shorted	The board detects a short circuit on the DHW NTC probe.	(2)(1)
33	DHW sensor open	The board detects an open contact on the DHW NTC probe.	(2)(1)
34	Low voltage	This occurs when the power supply voltage is lower than the allowed limits for correct operation of the appliance.	(2)(1)
37	Low water pressure	Sufficient water pressure inside the central heating circuit to guarantee the correct operation of the appliance is not detected.	Check the appliance pressure gauge to ensure the system pressure is between 1-1.2 bar and restore the correct pressure, if necessary. (2)(1)
43	Return sensor shorted	The board detects a short circuit on the return NTC probe.	(2)(1)
44	Return sensor open	The board detects an open contact on the return NTC probe.	(2)(1)
45	Flue sensor shorted	The board detects a short circuit on the flue NTC probe.	(2)(1)
46	Flue sensor open	The board detects an open contact on the flue NTC probe.	(2)(1)
47	Water pressure transducer fault	Possible pressure transducer or wiring fault.	(2)(1)
77	Mix zone overtemperature	The temperature read by the low temperature flow probe has exceeded the set limit.	(2)(1)
78	Mix zone sensor short	The board detects a short-circuit on the NTC probe of the mixed zone.	(2)(1)
79	Mix zone sensor open	The board detects an open contact on the NTC probe of the mixed zone.	(2)(1)
80	Supply and return sensor connection fault.	If the electrical connection between the two NTC probes is switched around, the board will detect the anomaly (it may be necessary to wait 3 minutes for the error to be detected).	Press the OK (Reset) button (1)
(1) If the shutdown or fault persists, contact an authorised company (e.g. Authorised After-Sales Technical Assistance Centre).			
(2) If normal operating conditions are restored, the appliance re-starts without having to be reset.			

Error Code	Anomaly signalled	Cause	Appliance status / Solution
82	Delta T protection	The boiler detects a sudden, unexpected increase in the ΔT between the flow probe and the system return probe. It can also be caused by a single defective sensor.	The burner is switched off to prevent any damage to the condensing module, once the correct ΔT has been restored and the time of 1 minute has elapsed since the appearance of the fault, the appliance returns to normal operation. Check that there is water circulation in the appliance, that the circulator is configured according to the system's requirements, and that the flow and return probes work correctly. (2) (1)
84	High Flue Temp limit	If the appliance malfunctions, too high a temperature is detected in the flue gas circuit and the appliance switches off.	Press the OK (Reset) button (1)
85	Pump fault	Possible blocked impeller, electrical fault, automatic re-release routine (duration 30 minutes) (the latter only applies to Wilo).	Switch off for at least 30 seconds and switch back on. (2) (1)
89	Incorrect parameter setting	Possible misconfiguration of some parameters in the simple cascade: - the parameter "System sensor" is not configured - the parameter "System sensor" is not configured in "DHW mode", but "DHW pump" has been configured via the "multifunction relays" - the parameter "System sensor" is configured in "DHW mode", but "DHW pump" has not been configured via the "multifunction relays" - the parameter "Boiler for DHW" was incorrectly set	(2) (1)
90	OpenTherm 1/2 connection lost	The device signals a loss of communication with the OpenTherm remote control mounted on Zone 1 or Zone 2, or with both thermostats (heating of the system is not guaranteed).	Check the connections to the communication BUS. Press the OK (Reset) button (the fault disappears and the device operates in independent mode until communication is restored). (2) (1)
(1) If the shutdown or fault persists, contact an authorised company (e.g. Authorised After-Sales Technical Assistance Centre).			
(2) If normal operating conditions are restored, the appliance re-starts without having to be reset.			

INSTALLER

USER

MAINTENANCE TECHNICIAN

TECHNICAL DATA



Error Code	Anomaly signalled	Cause	Appliance status / Solution
91	System sensor shorted	The board detects a short-circuit on the system-side flow NTC probe (no guarantee of efficient operation of the system).	(2) (1)
92	System sensor open	The board detects an open contact on the system-side flow NTC probe (no guarantee of efficient system operation).	(2) (1)
93	Outdoor sensor shorted	The board detects a short circuit on the external NTC probe (applicable if the parameter "CH Request type" in "HYDRAULIC SETTINGS" is set as "Room thermostat OTC" or "Only OTC").	(2) (1)
94	Display board fault	Error in the firmware version of the 'Display Board'.	(2) (1)
96	Outdoor sensor open	The board detects an open contact on the external NTC probe (applicable if the parameter "CH Request type" in "HYDRAULIC SETTINGS" is set as "Room thermostat OTC" or "Only OTC").	(2) (1)
97	Cascade mismatch	In the case of simple cascade, the P.C.B. of the Master appliance detects fewer boilers Slave in the chain than the last "Autodetect".	Check the connections to the simple cascade communication BUS, and repeat the "Autodetect" procedure in the "Cascade" menu. (2) (1)
98	Slave bus fault	In the case of simple cascade, the P.C.B. of the appliance Slave receives no communication from the boiler Master.	Check the connections to the simple cascade communication BUS (repeat the "Autodetect" procedure in the "Cascade" menu). This error will only appear on the display of the Slave devices (2) (1)
(1) If the shutdown or fault persists, contact an authorised company (e.g. Authorised After-Sales Technical Assistance Centre).			
(2) If normal operating conditions are restored, the appliance re-starts without having to be reset.			

Error Code	Anomaly signalled	Cause	Appliance status / Solution
99	Master bus fault	In the case of simple cascade, the P.C.B. of the Master appliance receives no communication from one or more boilers Slave (simple cascade will operate with fewer appliances). In the case of simple cascade, the role of the Slave devices has not been assigned in the correct sequence (the sequence must respect the numerical sequence and start from 1).	Check the connections to the simple cascade communication BUS, and repeat the "Autodetect" procedure in the "Cascade" menu. This error will only appear on the display of the Master appliance (2) (1)
100	External controller connection lost	The device signals a loss of communication with the cascade and zone regulator or the BMS system (central and DHW heating is not guaranteed).	Check the connections to the communication BUS. Press the Reset button (the fault disappears and the device operates in standalone mode until communication is restored). (2) (1)
101	Hydraulic configuration is incorrect	Possible misconfiguration of some parameters: - the parameter "Boiler for DHW" was incorrectly set - the parameter "3-way valve CH" or the parameter "3-way valve DHW" was incorrectly set via the 'multifunction relays'	(2) (1)
102	Maintenance reminder	Indicates that it is necessary to perform maintenance operations. If this signal is reset, it is re-proposed within 24 hours, until the date of the next maintenance is updated from the menu "TECHNICIAN".	Press the OK (Reset) button to temporarily clear the warning. Contact an authorised company (e.g. Authorised After-Sales Technical Assistance Centre).
(1) If the shutdown or fault persists, contact an authorised company (e.g. Authorised After-Sales Technical Assistance Centre).			
(2) If normal operating conditions are restored, the appliance re-starts without having to be reset.			

INSTALLER

USER

MAINTENANCE TECHNICIAN

TECHNICAL DATA



2.11 APPLIANCE SWITCH-OFF

Switch the appliance off by putting it in “off” mode, disconnect the main switch outside of the appliance and close the gas isolation valve upstream of the appliance.

Never leave the appliance switched on if left unused for prolonged periods.

2.12 RESTORE CENTRAL HEATING SYSTEM PRESSURE

1. Periodically check the system water pressure (the appliance’s pressure gauge hand must indicate a value of no less than 0.5 bar).
2. If the pressure is less than 0.5 bar (when the system is cold), it is necessary to restore the water in the system (in this case, remove water from an air-vent valve on a radiator until the pressure has been restored to 1 bar, or call in professionally qualified personnel).
3. Close the valve after the operation.



If pressure values reach around 5,4 bar the safety valve may be activated.

2.13 DRAINING THE SYSTEM

1. Open the draining valve (Par.1.64).
2. Open all vent valves.
3. Close all previously opened vent valves.



If fluid containing glycol was added to the system circuit, make sure it is recovered and disposed of in accordance with standard EN 1717.



2.14 ANTIFREEZE PROTECTION

The appliance has an antifreeze function that switches the burner on automatically when the temperature drops below 9°C (standard protection to minimum temperature of -5°C).

In order to guarantee the integrity of the appliance and the domestic hot water heating system in areas where the temperature drops below zero, we recommend protecting the central heating system using anti-freeze liquid and installing the Immergas Antifreeze Kit in the appliance.

If there is a storage tank in the system and a DHW probe, the burner is switched on when the temperature measured by the probe falls below 6°C and is switched off above 15°C.



For the antifreeze function to work properly, the storage tank must be filled with water; otherwise, the antifreeze can operate continuously.

2.15 PROLONGED INACTIVITY

In case of prolonged inactivity (e.g. second home), we recommend:

1. close the gas;
2. to switch off the power supply;
3. Completely empty the CH circuit (to be avoided if glycol is present in the system) and the DHW circuit of the appliance (if combined with a storage tank). In systems that are drained frequently, filling must be carried out with suitably treated water to eliminate hardness that can cause lime-scale.



Depending on the hydraulic configurations and options installed, there may be additional antifreeze functions (External probe, System sensor, Mixed probe).

2.16 CLEANING THE CASE

1. Use damp cloths and neutral detergent to clean the appliance casing.



Never use abrasive or powder detergents.

2.17 PERMANENT SHUTDOWN

In the event of permanent shutdown of the appliance, contact professional staff for the procedures and ensure that the electrical, water and gas supply lines are shut off and disconnected.



3 INSTRUCTIONS FOR MAINTENANCE AND INITIAL CHECK

3.1 GENERAL RECOMMENDATIONS



Operators who install and service the appliance must wear the personal protective equipment (PPE) required by applicable law.
The list of possible PPE is not complete as they are indicated by the employer.



Before carrying out any maintenance work, make sure that:

- you have disconnected the power to the appliance;
- you have closed the gas isolation valve;
- you have discharged the pressure from the system and domestic hot water circuit.

Risk of material damage after using sprays and liquids to search for leaks



Leak sprays and liquids clog the reference hole PR Ref. (Fig. 70) of the gas valve, damaging it irreparably.
During installation and maintenance, do not use spray or liquids in the upper area of the gas valve (electric connections side).

Supply of spare parts



The device's warranty shall be rendered null and void if unapproved or unsuitable parts are used for maintenance or repairs. These will also compromise the product's compliance, and the said product may no longer be valid and fail to meet the current regulations. In regard to the above, only use original Immergas spare parts when replacing components.



If additional documentation needs to be consulted for extraordinary maintenance, contact the Authorised After-Sales Service.

3.2 INITIAL CHECK

Commissioning the appliance requires you to:

- ensure that the type of gas used corresponds to the appliance settings (the type of gas appears on the data nameplate);
- check connection to a 230V-50Hz power mains, correct L-N polarity and the earthing connection;
- make sure the central heating system is filled with water and the cooling appliance pressure gauge reads a pressure of 1-1.2 bar;
- switch the appliance on and check correct ignition;
- check the proper calibration of the number of fan revolutions;
- check the CO₂/O₂ in the flue gas at maximum and minimum flow rate;
- the values comply with the relevant tables (Par. 3.3);
- fill in and affix the installation information sticker on the appliance next to the data nameplate, with the same data as in this instruction manual, in paragraph 1.3 on the facsimile of the sticker;
- check activation of the safety device in the event of no gas, as well as the relative activation time;
- check the activation of the main switch located upstream of the appliance;
- check that the intake and/or exhaust terminals are not blocked;
- ensure activation of all adjustment devices;
- seal the gas flow regulation devices (if the settings are changed);
- check the tightness of the hydraulic circuits;
- check ventilation and/or aeration of the installation room where provided;
- check the existing draught during normal functioning of the appliance, e.g. a draught gauge positioned at the exit of the appliance combustion products;
- check that there is no backflow of combustion products into the room, even during functioning of fans.



Even if just one single safety check provides a negative result, do not commission the system.



3.3 YEARLY APPLIANCE CHECK AND MAINTENANCE



The following checks and maintenance should be performed once a year to ensure operation, safety and efficiency of the appliance over time.

- Clean the flue side of the heat exchanger.
- Clean the main burner.
- Check the correct positioning, integrity and cleanliness of the detection and ignition electrode; remove any oxide present.
- If deposits are detected in the combustion chamber they must be removed and the heat exchanger coils must be cleaned using nylon or broomcorn brushes; it is forbidden to use brushes made of metal or other materials that may damage the combustion chamber. It is also forbidden to use alkaline or acid detergents.
- Check the integrity of the insulating panels inside the combustion chamber and if damaged replace them.
- Visually check for water leaks or oxidation from/on connections and traces of condensate residues inside the sealed chamber.
- Check the contents of the condensate drain trap.
- Visually check that the siphon is properly filled with condensate and top it up if necessary.
- Check that there are no material residues in the condensate drain siphon clogging the condensate passage; also check that the entire condensate drainage circuit is clear and efficient.
- In the event of obstructions (dirt, sediment, etc.) with consequent leakage of condensate in the combustion chamber, one must replace the insulating panels.
- Check that the burner and gas manifold seal gaskets are intact and perfectly efficient, otherwise replace them. In any case the gaskets must be replaced at least every two years, regardless of their state of wear.
- Check that the burner is intact, that it has no deformations or cuts and that it is properly fixed to the combustion chamber lid; otherwise it must be replaced.
- Visually check that the water safety drain valve is not blocked.
- Check that the system static pressure (with system cold and after refilling the system by means of the filling valve) is between 1 and 1.2 bar.
- Check visually that the safety and control devices have not been tampered with and/or shorted, in particular:
 - Flow and flue probes.
 - temperature safety thermostat.
- Check the condition and integrity of the electrical system and in particular:
 - The power cables must be inside the cable fixings.
 - there must be no traces of blackening or burning.
- Check correct lighting and operation.
- Check the CO₂/O₂ by using the chimney sweep function at the reference heat outputs, using the parameters entered in the following tables. If values outside the specified tolerances are detected, check the integrity of the ignition electrode and replace it if necessary, also replacing the relevant gasket. Now activate the "full calibration" function.
- Check correct calibration of the burner in central heating phase.
- Check correct operation of control and adjustment devices and in particular:
 - intervention of the main electrical switch on the appliance.
 - system regulation probes intervention.
- Check sealing efficiency of gas circuit and the internal system.
- Check the intervention of the device against no gas ionisation flame control. Intervention time must be less than 10 seconds.

Gas type	CO ₂ to Nominal Q.	CO ₂ to Minimum Q.
G20	9,1 (9,0 ÷ 9,4) %	8,5 (8,2 ÷ 8,6) %
G31	10,5 (10,4 ÷ 10,8) %	9,3 (9,0 ÷ 9,4) %

Gas type	O ₂ at Nominal Q.	O ₂ at Minimum Q.
G20	4,6 (4,8 ÷ 4,1) %	5,7 (6,2 ÷ 5,5) %



In addition to yearly maintenance, one must also check the energy efficiency of the thermal system, with frequency and procedures that comply with the indications of the technical regulations in force.



If a Hydrogen ready installation is planned for H₂ percentages up to 20%, (referring to the gas distributed in the network) all calibration of the gas valve must refer to the O₂ values in the table above.



When adjusting nominal heat input, if the O₂ values are not reached with the gas flow regulator completely open, no further adjustments are required.



In the case of an annual inspection of the device, the max CO must be less than 700 ppm (0% O₂). If the CO value is higher, the device requires maintenance/repair.

INSTALLER

USER

MAINTENANCE/TECHNICIAN

TECHNICAL DATA



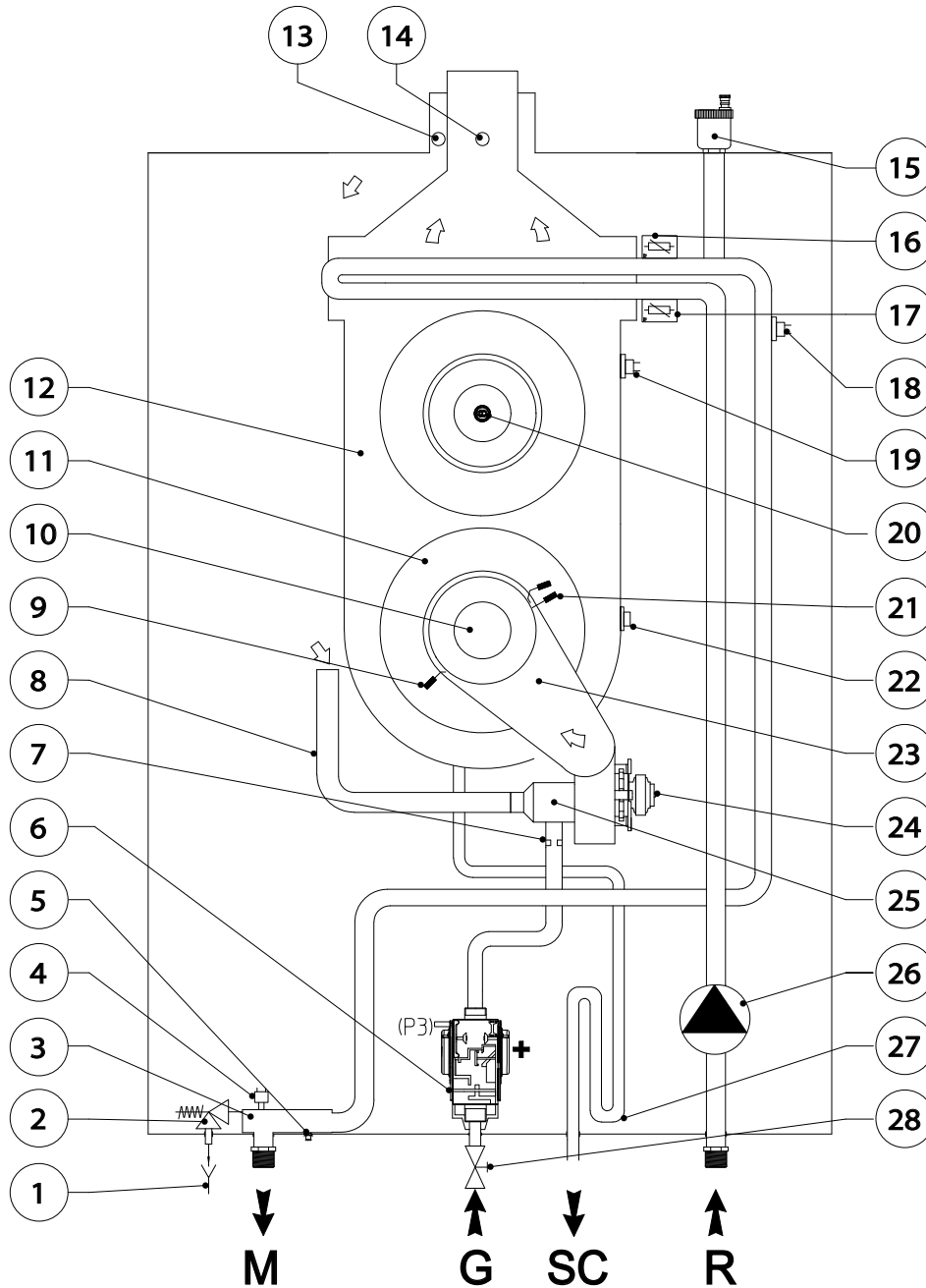

Key (Fig. 68):

- 1 - Tundish on view
- 2 - 5.4 bar safety valve
- 3 - Flow manifold
- 4 - Pressure transducer
- 5 - Device emptying valve
- 6 - Gas valve
- 7 - Gas nozzle
- 8 - Air intake pipe
- 9 - Detection electrode
- 10 - Burner
- 11 - Condensation module cover
- 12 - Condensation module
- 13 - Air sample point
- 14 - Flue sample point
- 15 - Condensation module air vent valve
- 16 - System flow regulation probe
- 17 - System return regulation probe
- 18 - Overheating safety thermostat
- 19 - Heat-exchanger safety thermostat (manual reset)
- 20 - Flue probe with thermofuse
- 21 - Ignition electrode
- 22 - Heat exchanger safety thermofuse
- 23 - Manifold cover
- 24 - Air fan
- 25 - Venturi
- 26 - Pump
- 27 - Condensate trap siphon
- 28 - Gas isolation valve

- M - System flow
- SC - Condensate drain
- G - Gas supply
- R - System return



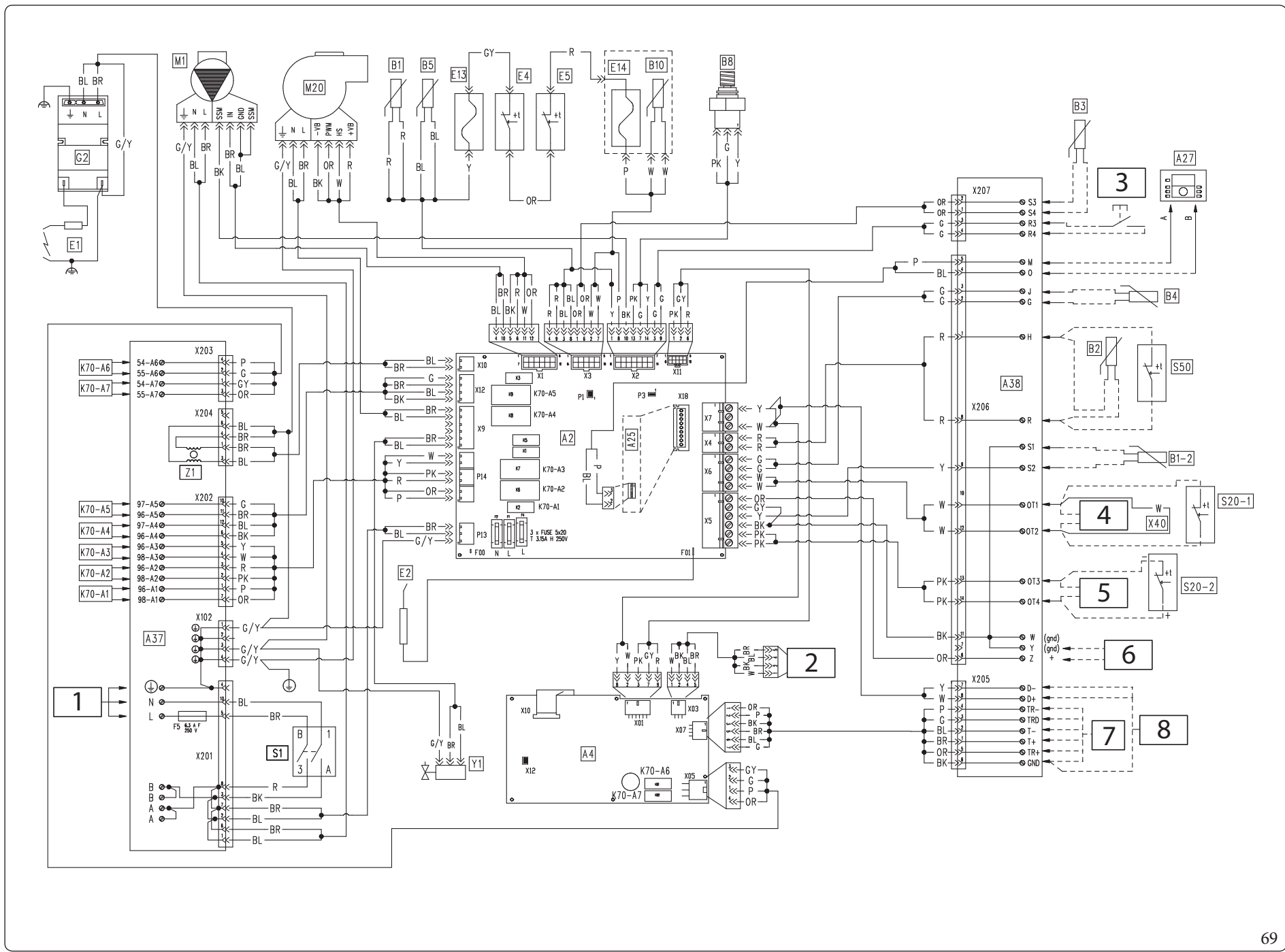

ST.007890/001

Victrix Pro V2 180 EU

111

TECHNICAL DATA

Key (Fig. 69):

- A2 - Circuit board
- A4 - Display board
- A25 - CLIP-IN (Optional)
- A27 - Cascade and zone regulator
- A37 - Connection sheet (loads)
- A38 - Connection card (signals)
- B1 - Flow probe
- B1-2 - System flow side probe (optional)
- B2 - DHW probe (optional)
- B3 - Low temperature flow probe (optional)
- B4 - External probe (optional)
- B5 - Return probe
- B8 - System pressure meter
- B10 - Flue probe
- E1 - Ignition glow plug
- E2 - Detection electrode
- E4 - Safety thermostat
- E5 - Exchanger safety thermostat (manual reset thermostat)
- E13 - Heat exchanger safety thermofuse
- E14 - Flue safety thermofuse
- F5 - Phase fuse
- F1 - Phase fuse
- F2 - Neutral fuse
- F4 - Phase fuse
- G2 - Igniter
- K1 - Gas valve relay (Line)
- K5 - Gas valve relay (Neutral)
- K3 - Igniter relay
- K70 - Multifunction relay
- M1 - Boiler circulating pump
- M20 - Fan
- P1 - SW update (iXTool)
- P3 - Pin (1&2) Communication jumper (Do not remove)

MAINTENANCE TECHNICIAN

- S1 - Main switch
- S20-1 - Room thermostat (optional) (Zone 1)
- S20-2 - Room thermostat (optional) (Zone 2)
- S50 - DHW Thermostat/Contact
- X12 - Software Update (iXTool)
- X40 - Room thermostat link
- Y1 - Gas valve
- Z1 - Antijamming filter

Key (Fig. 69):

- 1 - 230 Vac 50Hz Power supply
- 2 - Testing/iXTool (Bus microm)
- 3 - External reset
- 4 - Bus openTherm 1
- 5 - Bus openTherm 2
- 6 - 0-10 V analogue input
- 7 - Modbus (Slave)
- 8 - Modbus (Master)

Colour code key (Fig. 69):

- BK - Black
- BL - Blue
- BR - Brown
- CY - Cyan
- G - Green
- GY - Grey
- G/Y - Yellow/Green
- W/BK - White/Black
- OR - Orange
- P - Purple
- PK - Pink
- R - Red
- W - White
- Y - Yellow

USER

INSTALLER

Maximum loads on Relays of boards A2 and A4				
Multifunction relay	Voltage	Current	cosφ	From factory settings, K70 relays do not perform any functions.
K70-A2/K70-A3 K70-A4/K70-A5 K70-A1	230 Vac	<0,1 A	≥0,6	
K70-A6/K70-A7	Potential-free contact (230 Vac MAX)	<0,1 A	≥0,6	Insert an optional external relay to drive anyload.

Remove X40 link in case of connection:

- Cascade and zone regulator
- 0-10V
- BMS
- BUSOT
- Some types of central heating demand

For low-temperature zones, insert a safety thermostat in series with the relevant zone pump.

0-10 V analogue input:

If the 0-10V input is enabled via the appropriate parameter and if this input can become floating, insert a resistor of 2.2 to 50 kohm (4.7 kohm recommended) on terminals Y and Z.

OpenTherm:

Make sure that the OpenTherm thermostat is compatible with the appliance.

ELECTRICAL CONNECTIONS (SIGNALS)				
Components	Cable cross-section (mm ²)		Cable diameter (mm)	Maximum length (m)
	Minimum	Maximum		
* B1-2 * B2 * B3 * S50 * 0-10V	0,5	1,5	5 - 7	25 (2x25)
* B4 * S20-1 * S20-2 * OpenTherm	0,5	1,5	5 - 7	50 (2x50)
* External reset	0,5	1,5	5 - 7	10 (2x10)
* A27	J-Y(ST)Y 2x0.6			50 (2x50)



3.6 TROUBLESHOOTING

Trouble	Possible causes	Solutions
Smell of gas	Caused by leakage from gas circuit pipelines.	Check sealing efficiency of gas intake circuit.
Repeated ignition blocks	No gas.	Check the presence of pressure in the network and that the gas adduction valve is open. Incorrect adjustment of the gas valve, check the correct calibration of the gas valve.
Irregular combustion or noisiness	Dirty burner, incorrect combustion parameters, intake-exhaust terminal not correctly installed.	Clean the above components and ensure correct installation of the terminal, check correct setting of the gas valve (Off-Set setting) and correct percentage of CO ₂ in flue gas.
The overheating safety thermostat, the flow probe or the return probe are triggered frequently	No water in the boiler, poor water circulation in the system or blocked circulator.	Check on the pressure gauge that the system pressure is within established limits. Check that the radiator valves are not all closed and the functionality of the circulator. Check the integrity of the thermo-fuse, in case of intervention of which check the integrity of the module and the smoke circuit. Check that the heat exchanger safety thermostat has not tripped; if it has, check the integrity of the module, the ceramic fibre panel, replace the manifold cover sealing gasket and reset the thermostat by pressing the button on it.
Siphon blocked	Dirt or combustion products deposited inside.	Check that there are no residues of material blocking the flow of condensate.
Heat exchanger blocked.	Obstruction of the siphon.	Check that there are no residues of material blocking the flow of condensate.
Abnormal noises in the system	Air in the system.	Check opening of the special air vent valve cap (Par. 1.64). Check that system filling and deaeration has been performed as prescribed.
Abnormal noises in the condensation module	Air in the module.	Use the manual air vent valve (Parag. 1.64) to remove any air inside the condensation module. When the operation has been performed, close the manual air vent valve.
No domestic hot water production	Optional DHW NTC probe malfunction.	If there is a power outage, or if the boiler is switched off and back on again during the failure, it will not be possible to detect said failure, but it will, however, be recorded in the errors anomaly records.



In case of $\Delta T > 35^{\circ}\text{C}$, the appliance switches off and signals error "82".

INSTALLER

USER

MAINTENANCE TECHNICIAN

TECHNICAL DATA



3.7 TECHNICAL MENU

Press the "MENU" button to access a list of variables that enable you to customise use of the system. Hereunder is a list of all available menus:

MENU		
	Menu item	Description
1.	USER	Allows selection of the user menu
2.	TECHNICIAN	Allows selection of the technical menu (access allowed via password for Service only)



To access the technical menu, enter the password '123' using the '+' and '-' buttons, pressing 'OK' with each entered digit.

Technical Menu

TECHNICIAN MENU	
1.	HYDRAULIC SETTINGS
2.	CH SETTINGS
3.	Domestic hot water
4.	SYSTEM SETTINGS
5.	DIAGNOSTICS
6.	MANUAL TEST
7.	DEAERATION
8.	CASCADE
9.	RESTORE SETTINGS

TECHNICIAN MENU/HYDRAULIC SETTINGS	
1.	Relay settings
2.	System sensor
3.	Mix zone
4.	CH Request type
5.	DHW request type
6.	Parallel mode
7.	3-way valve



The "Restore settings" column in the following tables represents the parameters that can be reset to default values or another value (indicated in the column itself) by means of a specific item in the "Restore settings" menu. For simple cascade, please refer to the cascade booklet.

TECHNICIAN MENU/HYDRAULIC SETTINGS/RELAY SETTINGS							
Menu item	Description	Range	Default	Restore settings	Synchronisation Slave	Value customized	
1.	K70-A1	Relay not used Booster pump Zone 1 pump Zone 2 pump System pump* DHW pump System fault 3-way valve CH 3-way valve DHW Burner on Mixing valve: opens Mixing valve: closes	Relay not used	Yes	No		
2.	K70-A2			Yes	No		
3.	K70-A3			Yes	No		
4.	K70-A4			Yes	No		
5.	K70-A5			Each relay has a dedicated parameter to determine its operation N.B.: The first five relays are on the P.C.B., while the other two are on the display board.	Yes	No	
6.	K70-A6			Relay not used	Yes	No	
7.	K70-A7			Zone 1 pump Zone 2 pump System pump* DHW pump System fault Burner on Mixing valve: opens Mixing valve: closes	Yes	No	
8.	System pump configuration*	The parameter is particularly suitable in the Zone 1 + Zone 2 configuration (see wiring diagram in Parag. 1.23) where there is only one circulator serving two zones with two separate thermostats.	not used	Yes	-		

*Once the system pump parameter has been selected on the relay, the system pump configuration parameter must also be set, which determines the operation of "Zone 1 pump" and/or "Zone 2 pump" and/or "Domestic hot water".

INSTALLER

USER

MAINTENANCE TECHNICIAN

TECHNICIAN MENU/HYDRAULIC SETTINGS/SYSTEM SENSOR					
Menu item	Description	Range	Default	Restore settings	Value customized
Not used	The plant (system) sensor configuration determines how the sensor is used	Not used CH mode DHW mode CH + DHW mode	Not used	Yes	
CH mode					
DHW mode*					
CH + DHW mode					

* Use for single appliance only. In the case of simple cascade, the parameter "CH + DHW mode" must necessarily be selected, otherwise error 89 is displayed.

TECHNICAL DATA



TECHNICIAN MENU/HYDRAULIC SETTINGS/MIX ZONE

Menu item		Description	Range	Default	Restore settings	Value customized
1.	Mix zone selection*	Selects the mixed heating zone (mixing valve, sensor). Only one heating zone can be equipped with a mixing valve.	1 ÷ 2	2	Yes	
2.	Valve travel time	Running time of the mixing valve. Enter the correct value for the mixing valve used.	1 ÷ 240 (s)	150 (s)	Yes	
3.	High temperature protection	Limitation of the maximum allowed control setpoint for the mixed zone (The parameter value - 3°C. The parameter value increased by 3°C defines the over-temperature threshold of the mixed zone (see Error 77).	20 ÷ 80 (°C)	45 (°C)	Yes	
4.	Hysteresis	If the temperature difference between the heating setpoint of the mixed zone and the temperature measured by the low temperature flow sensor is less than the hysteresis value, the mixing valve is not actuated. If the hysteresis is greater, the mixing valve is actuated according to the control algorithm.	1 ÷ 10 (°C)	1 (°C)	Yes	
5.	Loop time	Control cycle time of the mixing valve control algorithm. Higher values make the response of the control algorithm slower (the mixing valve is actuated less frequently) vice versa the mixing valve is actuated more frequently.	1 ÷ 60 (s)	15 (s)	Yes	
6.	K factor	Gain factor for the control of the mixing valve: the time during which the mixing valve is actuated is given by the value of the difference between the heating setpoint of the mixed zone and the temperature measured by the low temperature flow sensor, multiplied by "K factor".	1 ÷ 30	1	Yes	

*1 = Mixing valve used on zone 1 / 2 = Mixing valve used on zone 2

INSTALLER

USER

MAINTENANCE TECHNICIAN

TECHNICAL DATA



TECHNICIAN MENU/HYDRAULIC SETTINGS/CH REQUEST TYPE					
Menu item	Description	Range	Default	Restore settings	Value customized
Room thermostat OTC	They allow the selection of different CH demands according to the type of installation: See diagrams in paragraphs 1.16, 1.26.	Room thermostat OTC Room thermostat setpoint Only OTC Constant Setpoint 0-10 V Power control 0-10 V Temperature control.	Room thermostat setpoint	Yes	
Room thermostat setpoint					
Only OTC					
Constant Setpoint					
0-10 V Power control					
0-10 V Temperature control					

TECHNICIAN MENU/HYDRAULIC SETTINGS/DHW REQUEST TYPE					
Menu item	Description	Range	Default	Restore settings	Value customized
Thermostat	Allows you to select the demand type for DHW.	Thermostat ÷ Sensor	Thermostat	Yes	
Sensor					

TECHNICIAN MENU/HYDRAULIC SETTINGS/PARALLEL MODE					
Menu item	Description	Range	Default	Restore settings	Value customized
Disabled	Parallel mode allows simultaneous satisfaction of "CH Demand" and "DHW Demand". This mode requires a suitable hydraulic configuration.	Disabled ÷ Enabled	Disabled	Yes	
Enabled					

INSTALLER

USER

MAINTENANCE/TECHNICIAN

TECHNICAL DATA



TECHNICIANMENU/HYDRAULICSETTINGS/3-WAY VALVE						
Menu item		Description	Range	Default	Restore settings	Value customized
1.	3-way valve selection	3-way valve selection: Motorized (Motorised diverter valve) Spring return (Diverter valve with spring return) See diagrams in paragraphs 1.16, 1.26.	Motorized ÷ Spring return	Motorized	Yes	
2.	Travel time	Defines the time during which the 'electric' valve is energised to switch the position from the DHW circuit to the CH circuit and vice versa.	1 ÷ 255 (s)	12 (s)	Yes	
3.	Default position	Selects the position of the valve at rest: CH DHW	CH ÷ DHW	CH	Yes	

TECHNICIAN MENU/CH SETTINGS	
1.	Power set
2.	Temperatures
3.	Overtemperature
4.	Outside temperature
5.	Timing setting

TECHNICIANMENU/CH SETTINGS/POWERSET						
Menu item		Description	Range	Default	Restore settings	Customised value
1.	Maximum power	Sets the percentage of the boiler's "Maximum power" in CH mode	Minimum power ÷ 100 (%)	100 (%)	Yes	
2.	Minimum power	Sets the percentage of the boiler's "Minimum power" in CH mode	0 ÷ Maximum power (%)	0 (%)	Yes	



TECHNICIANMENU/CHSETTINGS/TEMPERATURES						
Menu item		Description	Range	Default	Restore settings	Customised value
1.	Zone 1 maximum CH setpoint	Set the "Zone 1 maximum CH setpoint".	15 ÷ 90 (°C)	85 (°C)	Yes	
2.	Zone 1 minimum CH setpoint	Set the "Zone 1 minimum CH setpoint".	15 ÷ Zone 1 maximum CH setpoint (°C)	20 (°C)	Yes	
3.	Zone 1 CH setpoint	Set the "Zone 1 CH setpoint" (can also be set by the user). Please note that this parameter can change the parameter "Zone 1 CH holiday setpoint".	Zone 1 minimum CH setpoint ÷ Zone 1 maximum CH setpoint (°C)	85 (°C)	Yes	
4.	Zone 2 maximum CH setpoint	Set the "Zone 2 maximum CH setpoint".	15 ÷ 90 (°C)	40 (°C)	Yes	
5.	Zone 2 minimum CH setpoint	Set the "Zone 2 minimum CH setpoint".	15 ÷ Zone 2 maximum CH setpoint (°C)	20 (°C)	Yes	
6.	Zone 2 CH setpoint	Set the "Zone 2 CH setpoint" (can also be set by the user). Please note that this parameter can change the parameter "Zone 2 CH holiday setpoint".	Zone 2 minimum CH setpoint ÷ Zone 2 maximum CH setpoint (°C)	35 (°C)	Yes	
7.	CH setpoint hysteresis	Sets the hysteresis of the CH setpoint (single for both zones).	2 ÷ 10 (°C)	5 (°C)	Yes	

INSTALLER

USER

MAINTENANCE/TECHNICIAN

TECHNICAL DATA



TECHNICIAN MENU/CH SETTINGS/TEMPERATURES

Menu item	Description	Range	Default	Restore settings	Customised value
8.	Zone 1 CHECO setpoint reduction	0 ÷ 50 (°C)	30 (°C)	Yes	
9.	Zone 2 CHECO setpoint reduction	0 ÷ 50 (°C)	5 (°C)	Yes	
10.	ECO shutdown hysteresis CH Zone 1*	0 ÷ 20 (°C)	0 (°C)	Yes	

* Caution when using these parameters in combination with the parameters "Zone 1 CHECO setpoint reduction", "Zone 2 CHECO setpoint reduction" of this menu and "Zone 1 Offset", "Zone 2 Offset" of the menu "Outdoor temperature", as it may inhibit the CH demand in an unintended manner.

INSTALLER

USER

MAINTENANCE TECHNICIAN

TECHNICAL DATA



TECHNICIANMENU/CHSETTINGS/TEMPERATURES

Menu item	Description	Range	Default	Restore settings	Customised value
11.	ECO shutdown hysteresis CH Zone 2*	0 ÷ 20 (°C)	0 (°C)	Yes	
	<p>If set other than 0 and when the "ECO" mode is active, the CH demand is inhibited when the calculated setpoint is lower than the temperature set on parameter "Zone 2 CH setpoint".</p> <p>The request is unlocked if the calculated setpoint is greater than the temperature given by the sum of parameter "Zone 2 CH setpoint" + ECO shutdown hysteresis CH Zone 2.</p> <p>This parameter takes effect when the function ECO is activated pressing the button "ECO" or according to schedule.</p>				
12.	Zone 1 CH constant setpoint reduction	0 ÷ 80 (°C)	0 (°C)	Yes	
	<p>Defines the level for reducing the control setpoint for zone 1 heating when the room thermostat contact is open.</p> <p>Only applies if the CH demand type parameter is set as a constant setpoint (can also be set by the user).</p>				
13.	Zone 2 CH constant setpoint reduction	0 ÷ 80 (°C)	0 (°C)	Yes	
	<p>Defines the level for reducing the control setpoint for zone 2 heating when the room thermostat contact is open.</p> <p>Only applies if the CH demand type parameter is set as a constant setpoint (can also be set by the user).</p>				

* Caution when using these parameters in combination with the parameters "Zone 1 CH ECO setpoint reduction", "Zone 2 CH ECO setpoint reduction" of this menu and "Zone 1 Offset", "Zone 2 Offset" of the menu "Outdoor temperature", as it may inhibit the CH demand in an unintended manner.

INSTALLER

USER

MAINTENANCE/TECHNICIAN

TECHNICAL DATA



TECHNICIAN MENU/CH SETTINGS/OVERTEMPERATURE

Menu item		Description	Range	Default	Restore settings	Customised value
1.	Overtemperature timer*	Each time the burner is switched on and during the time set by the parameter "Overtemperature timer", the burner is switched off at a temperature value increased by the parameter "Overtemperature hysteresis add"	0 ÷ 10 (min)	2 (min)	Yes	
2.	Overtemperature hysteresis add*		0 ÷ 30 (°C)	5 (°C)	Yes	

* 0 = OFF

TECHNICIAN MENU/CH SETTINGS/OUTSIDE TEMPERATURE

Menu item		Description	Range	Default	Restore settings	Customised value
1.	Outside temperature for max CH	Defines the outside temperature at which the OTC will set the maximum CH setpoint.	-34 ÷ (-10) (°C)	-10 (°C)	Yes	
2.	Outside temperature for min CH	Defines the outside temperature at which the OTC will set the minimum CH setpoint.	15 ÷ 25 (°C)	18 (°C)	Yes	
3.	Outside temperature for CH off	Defines the outside temperature at which the central heating demand will be disabled. The function is active even if the parameter "CH Request type" in "HYDRAULIC SETTINGS" is not set as "Room thermostat OTC" or "Only OTC".	7 ÷ 25 (°C)	OFF (°C)	Yes	
4.	Zone 1 Offset	This is the offset value to be added on zone 1 to the setpoint calculated from the OTC curve (can also be set by the user).	-15 ÷ 15 (°C)	0 (°C)	Yes	
5.	Zone 2 Offset	This is the offset value to be added on zone 2 to the setpoint calculated from the OTC curve (can also be set by the user).	-15 ÷ 15 (°C)	0 (°C)	Yes	
6.	Zone 1 Table	Displays the linkage table between "Outside temperature" and the actual setpoint of zone 1.	-	-	-	-
7.	Zone 1 Curve	Displays the graph of the link between the "Outside temperature" and the actual setpoint of zone 1.	-	-	-	-
8.	Zone 2 Table	Displays the linkage table between "Outside temperature" and the actual setpoint of zone 2.	-	-	-	-
9.	Zone 2 Curve	Displays the graph of the link between the "Outside temperature" and the actual setpoint of zone 2.	-	-	-	-

For OTC operation, the parameter "CH Request type" must be set as "Room thermostat OTC" or "Only OTC".



TECHNICIAN MENU/CH SETTINGS/TIMING SETTING							
Menu item		Description	Range	Default	Restore settings	Synchronisation Slave	Customised value
1.	Post pump time	Set the heating pump delay time	0 ÷ 20 (min)	3 (min)	Yes	Yes	
2.	Anticycling timer	Set the anti-cycle timer (minimum time between boiler switch-off and next switch-on)	0 ÷ 15 (min)	3 (min)	Yes	-	
3.	CH ramp	The boiler output is adjusted so that the temperature read by the flow sensor increases according to the parameter setting (0 = output increases to the maximum permissible system speed).	0 ÷ 60 (°C/min)	4 (°C/min)	Yes	-	
4.	Minimum time	Time during which the burner remains at minimum power for the set time.	0 ÷ 10 (min)	0 (min)	Yes	-	

INSTALLER

TECHNICIAN MENU/DOMESTIC HOT WATER	
1.	Power set
2.	Temperatures
3.	Timing setting
4.	Antilegionella*

*When "HYDRAULIC SETTINGS/DHW request type" is set to "Thermostat", the item "Antilegionella" will not be present

USER

TECHNICIAN MENU/DOMESTIC HOT WATER/POWERSET						
Menu item		Description	Range	Default	Restore settings	Customised value
1.	Maximum power	Sets the percentage of maximum boiler power in the "DHW" mode.	Minimum power ÷ 100 (%)	50 (%)	Yes	
2.	Minimum power	Sets the minimum boiler power percentage in the "DHW" mode.	0 ÷ Maximum power (%)	0 (%)	Yes	

MAINTENANCE/TECHNICIAN

TECHNICAL DATA



When Thermostat is set in Technician menu/HYDRAULIC SETTINGS/DHW request type, the table below will look like this:

TECHNICIAN MENU/DOMESTIC HOT WATER/TEMPERATURES						
Menu item		Description	Range	Default	Restore settings	Customised value
1.	Storage temperature setpoint	Sets the flow temperature during the "Domestic hot water" mode.	35 ÷ 87 (°C)	80 (°C)	Yes	

When Sensor is set in Technician menu/HYDRAULIC SETTINGS/DHW request type, the table below will look like this:

TECHNICIAN MENU/DOMESTIC HOT WATER/TEMPERATURES						
Menu item		Description	Range	Default	Restore settings	Customised value
1.	DHW maximum setpoint	Set the "DHW maximum setpoint"; if set lower than "DHW setpoint", this parameter will adjust to the new value and remain there even if the parameter "DHW maximum setpoint" is increased.	40 ÷ 87 (°C)	65 (°C)	Yes	
2.	DHW setpoint	Set the "DHW setpoint" (which can also be set by the user).	20 ÷ DHW maximum setpoint (°C)	65 (°C)	Yes	
3.	DHW setpoint hysteresis	Set "Hysteresis" for "DHW setpoint".	0 ÷ 10 (°C)	5 (°C)	Yes	
4.	DHW storage offset	This value added to "DHW setpoint" determines the flow setpoint during the "Domestic hot water" function.	0 ÷ 30 (°C)	15 (°C)	Yes	
5.	ECO setpoint reduction	Sets the temperature that will be subtracted from DHW setpoint when the "ECO" mode is activated.	0 ÷ 50 (°C)	20 (°C)	Yes	



TECHNICIAN MENU/DOMESTIC HOT WATER/TIMING SETTING							
Menu item		Description	Range	Default	Restore settings	Synchronisation Slave	Customised value
1.	Post pump time	Set the "DHW Postpump" time in seconds.	0 ÷ 59 (s)	0 (s)	Yes	Yes	
2.	Post pump time	Set the time for "DHW Postpump" in minutes.	0 ÷ 30 (min)	1 (min)	Yes	Yes	
3.	Over temperature timer	Each time the burner is switched on and during the time set by the parameter "Over-temperature timer", the burner is switched off at the flow setpoint increased by 4°C.	0 ÷ 255 (s)	60 (s)	Yes	-	

When Sensor is set in Technician menu/HYDRAULIC SETTINGS/DHW request type, the table below will look like this:

TECHNICIAN MENU/DOMESTIC HOT WATER/ANTILEGIONELLA						
Menu item		Description	Range	Default	Restore settings	Customised value
1.	Function*	Activates or deactivates the function (ON / OFF).	Disabled ÷ Enabled	Disabled	Yes	
2.	Setpoint*	Defines the setpoint "DHW" (DHW probe) during the anti-legionella function.	60 ÷ 87 (°C)	60 (°C)	Yes	
3.	Duration*	Defines the maximum time of the anti-legionella prevention function.	15 ÷ 255 (min)	15 (min)	Yes	
4.	Period**	Defines the repetition period of the 'Antilegionella' function.	24 ÷ 168 (h)	168 (h)	Yes	
5.	Day of the week***	Defines the day of the week on which the 'Antilegionella' function will be activated.	Monday ÷ Sunday	Sunday	Yes	
6.	Hour of the day***	Defines the time of day when 'Antilegionella' will be activated.	0 ÷ 23 (h)	2 (h)	Yes	
7.	Manually force****	For details, see Parag. 1.58.	-	-	Yes	

* This parameter is used regardless of whether time programming is active or not

** This parameter is used when hourly/daily programming is not set

*** This parameter is used when hourly/daily programming is set

**** This parameter only appears if the parameter "Function" is enabled and the DHW is not disabled via the MODE button (See paragraph Control panel).

INSTALLER

USER

MAINTENANCE/TECHNICIAN

TECHNICAL DATA



TECHNICIAN MENU/SYSTEM SETTINGS	
1.	Fan parameters
2.	Pump parameters
3.	Delta T parameters
4.	Boiler antifreeze protection
5.	Additional antifreeze protections
6.	Decreasing slope
7.	User interface settings
8.	Anti-humidity settings
9.	Modbus parameters
10.	Maintenance

TECHNICIAN MENU/SYSTEM SETTINGS/FAN PARAMETERS							
Menu item	Description	Range	Default Appliance	Restore settings	Synchronisation Slave	Customised value	
1.	Ignition speed*	Sets the speed used during burner ignition.	750-6750 (rpm)	See table par-ag."4.2 Combustion parameters".	No	No	
2.	Maximum speed**	This defines the max fan speed and therefore the maximum relative operating power of the appliance. If you need to vary the CH and DHW output of the appliance, use the parameter "Maximum power".	Minimum speed ÷ 12750 (rpm)	See table par-ag."4.1 Variable heat output".	No	No	
3.	Minimum speed***	This defines the min fan speed and therefore the minimum relative appliance operating power.	300 ÷ Maximum speed (rpm)	See table par-ag."4.1 Variable heat output".	No	No	
4.	Postpurge speed	Defines the fan speed in the post-purge phase	0-12750 (rpm)	See table par-ag."4.2 Combustion parameters".	No	No	
* This parameter can be stored at a value greater than "Maximum speed" and less than "Minimum speed" but functionally, it will be limited by these two parameters.							
** When changing the value, it is possible to exceed the limit set by the parameter "Minimum speed", but when confirming, the previously stored value is retained.							
*** When changing the value, it is possible to exceed the limit set by the parameter "Maximum speed", but when confirming, the previously stored value is retained.							



TECHNICIAN MENU/SYSTEM SETTINGS/PUMP PARAMETERS							
Menu item	Description	Range	Default Appliance	Restore settings	Synchronisation Slave	Value customized	
1.	Feedback	Disabled = pump feedback is not used Enabled = pump feedback is used	Disabled - Enabled	Enabled	No	No	
2.	Feedback signal type	See table below	-	-	-	No	
3.	Pump minimum speed	Defines the minimum pump speed expressed as a percentage (do not go below the default value)	50 ÷ 100 %	50 %	No	No	
4.	Pump maximum speed	Defines the maximum pump speed expressed as a percentage	50 ÷ 100 %	100 %	No	No	
5.	Pump start speed	Defines the speed of the circulator during the burner ignition phase (do not go below the default value)	50 ÷ 100 %	50 %	No	No	
6.	CH pump continuous operation	Enables continuous pump operation in CH mode	Disabled - Enabled	Disabled	Yes	No	

TECHNICIAN MENU/SYSTEM SETTINGS/PUMP PARAMETERS/FEEDBACK SIGNAL TYPE						
Menu item	Description	Range	Default Appliance	Restore settings	Value customized	
PWM	PWM = the pump feedback signal is a PWM-based signal - selectable between WILO and GRUNDFOS	WILO - GRUNDFOS	RELAY	No		
RELAY	RELAY = the pump feedback signal is a signal based on RELAY (ON / OFF) potential-free contact	RELAY				

INSTALLER

USER

MAINTENANCE/TECHNICIAN

TECHNICAL DATA



TECHNICIAN MENU/SYSTEM SETTINGS/DELTA T PARAMETERS

Menu item		Description	Range	Default	Restore settings	Synchronisation Slave	Customised value
1.	Pump control	The pump speed increases in order not to exceed the value set in this parameter	1 ÷ 30 (°C)	18 (°C)	Yes	No	
2.	Power control	The boiler output is reduced not to exceed the value set in this parameter (Caution, do not change this parameter)	0 ÷ 60 (°C)	25 (°C)	Yes	No	

TECHNICIAN MENU/SYSTEM SETTINGS/BOILER ANTIFREEZE PROTECTION

Menu item		Description	Range	Default	Restore settings	Customised value
1.	Antifreeze activation temperature	Defines the antifreeze activation threshold. This threshold is monitored by the flow probe in order to protect the device.	0 ÷ 14 (°C)	9 (°C)	Yes	
2.	Antifreeze deactivation temperature	Defines the antifreeze deactivation threshold. This threshold is monitored by the flow probe in order to protect the device.	15 ÷ 40 (°C)	35 (°C)	Yes	

TECHNICIAN MENU/SYSTEM SETTINGS/ADDITIONAL ANTIFREEZE PROTECTIONS

Menu item		Description	Range	Default	Restore settings	Customised value
1.	Antifreeze activation temperature	Defines the antifreeze activation threshold. This threshold is monitored by the (system) sensor (if present) in order to protect the system.	2 ÷ 20 (°C)	5 (°C)	Yes	
2.	Antifreeze deactivation temperature	Defines the antifreeze deactivation threshold. This threshold is monitored by the system sensor (if present).	2 ÷ 20 (°C)	15 (°C)	Yes	
3.	Outside temperature pump activation	Defines the threshold for activating the system's circulators with reference to the temperature measured by the external probe. The function is active even if the parameter "CH Request type" in "HYDRAULIC SETTINGS" is not set as "Room thermostat OTC" or "Only OTC".	-30 ÷ 10 (°C)	-10 (°C)	Yes	



TECHNICIAN MENU/SYSTEM SETTINGS/DECREASING SLOPE							
Menu item		Description	Range	Default	Restore settings	Synchronisation Slave	Customised value
1.	Power threshold	The "Decreasing slope" is only activated each time the burner is switched on. "Decreasing slope" is activated each time the burner is ignited, and serves to prevent burner problems.	0 ÷ 100 (%)	50 (%)	Yes	No	
2.	Step time	Defines the time of the power decrease step.	0 ÷ 255 (s)	9 (s)	Yes	No	
3.	Duration	This is the maximum duration of 'Function'.	0 ÷ 10 (min)	3 (min)	Yes	No	



For the "User interface settings" menu items, see the relevant table in the User chapter.

TECHNICIAN MENU/SYSTEM SETTINGS/ANTI-HUMIDITY SETTINGS							
Menu item		Description	Range	Default	Restore settings	Synchronisation Slave	Customised value
1.	Anti-humidity function	Allows you to activate "Function".	OFF ÷ ON	OFF	Yes	Yes	
2.	Fanspeed	Defines the fan speed during this "Function".	0 ÷ 12750 (rpm)	3000 (rpm)	Yes	Yes	

TECHNICIAN MENU/SYSTEM SETTINGS/MODBUS PARAMETERS							
Menu item		Description	Range	Default	Restore settings	Customised value	
1.	Address	Allows the assignment of the Modbus slave address (when used with BMS systems).	1 ÷ 247	1	Yes		
2.	Baudrate	Modbus transmission rate (when used with BMS systems).	1200 2400 4800 9600 19200 38400	9600	Yes		
3.	Frame	The first digit (8 fixed value) defines the number of bits per byte. The second digit defines parity (N = No / E = Even / O = Odd). The third digit defines the stop bit (1-2 = Stop bits). (when used with BMS systems).	8O1 8E1 8N1 8O2 8E2 8N2	8E1	Yes		



TECHNICIAN MENU/SYSTEM SETTINGS/MAINTENANCE

	Menu item	Description
1.	Service information	Used to enter the telephone number of the service centre.
2.	Service due date	Date of next maintenance.

In the case of simple cascade, the function is only present on the Master device. The two parameters "MAINTENANCE" are not modified by the function "Restore settings", see also error code 102.

INSTALLER



For the "Boiler state" menu items, see the relevant table in the User chapter.



For the "System information" menu items, see the relevant table in the User chapter.

USER



For the "Lockout history" menu items, see the relevant table in the User chapter.



For the "Boiler statistics" menu items, see the relevant table in the User chapter.



For the "Firmware release" menu items, see the relevant table in the User chapter.

MAINTENANCE/TECHNICIAN

TECHNICAL DATA



TECHNICIAN MENU/MANUAL TEST		
Menu item	Description	
1.	Chimneysweep	Activates "Function" "Chimney sweep" for single boiler or for one or more boilers if simple cascade installation (for more details, see par. 3.11).
2.	Manual relay test	Check the "Function" associated with the relay previously set in "Technician menu/HYDRAULIC SETTINGS/Relay settings". The "Function" can be deactivated manually, but in any case it is deactivated automatically after 30 minutes. In the case of simple cascade, the function can only be activated by the Master device.

TECHNICIAN MENU/MANUAL TEST/MANUAL RELAY TEST			
Menu item	Description	Range	Default
System pump	The relay associated with "Function" is activated if previously configured in "Technician menu/HYDRAULIC SETTINGS/Relay settings".	OFF ÷ ON	OFF
DHW			
System fault			
3-way valve CH			
3-way valve DHW			
Burner on			
Mixing valve: opens			
Mixing valve: closes			

TECHNICIAN MENU/DEAERATION						
Menu item	Description	Range	Default	Restore settings	Customised value	
1.	Automatic function	Enables/disables the automatic operation of the short function after each power-up of the boiler.	Disabled ÷ Enabled	Enabled	Yes	
2.	Manual shorter function	Activate "Manual shorter function" once.	-	-	No	
3.	Manual longer function	Activate "Manual longer function" once.	-	-	No	

INSTALLER

USER

MAINTENANCE/TECHNICIAN

TECHNICAL DATA



TECHNICIAN MENU/CASCADE	
1.	Settings
2.	Single burner power
3.	Autodetect
4.	Parameter synchronization

TECHNICIAN MENU/CASCADE/SETTINGS						
Menu item	Description	Range	Default	Restore settings	Customised value	
1.	Activation and deactivation delay	This parameter is used to set the activation delay for all appliances except the pin appliance. The ignition delay of the appliances is not only given by this parameter but also by the regulating algorithm.	0 ÷ 255 (s)	30 (s)	Yes	
2.	Compensation of the KI factor	This parameter slows down the integral part of the control algorithm. If the activation of the appliances after the pin appliance is too slow, lower this value (the use of the 'Activation and deactivation delay' parameter is preferable in any case).	0 ÷ 255 (s)	30 (s)	Yes	
3.	PI loop period	This parameter indicates how often the calculation of the control algorithm is performed. A lower value makes the system faster but also more unstable, while a higher value makes the system more stable but less responsive to changes.	1 ÷ 15 (s)	5 (s)	Yes	
4.	Boiler for DHW	Attention, do not change this parameter.	0 ÷ 6	0	Yes	
5.	Heterogeneous power with boiler for DHW	Attention, do not change this parameter.	Disabled - Enabled	Disabled	Yes	



TECHNICIAN MENU/CASCADE/SINGLE BURNER POWER

Menu item	Description	Range	Default	Restore settings	Synchronisation Slave	Customised value
1.	Maximum	0 ÷ 255 (kW)	170	No	No	
2.	Minimum modulation level	0 ÷ 100 (%)	20	No	No	

INSTALLER

USER

TECHNICIAN MENU/CASCADE/AUTODETECT

Master appliance: the function called up by this parameter is used to detect the number of appliances in cascade.
Slave appliance: the function called up by this parameter is used to set the role of the Slave appliance in cascade, although normally this menu is opened automatically by activating this function from Master
 This function can also be used to set a Master or Slave appliance as a single appliance.
 For more details, see paragraph "1.53".

MAINTENANCE/TECHNICIAN

TECHNICIAN MENU/CASCADE/PARAMETERS SYNCHRONIZATION

WARNING: read and understand what is stated in paragraph 1.54 "Restore settings and parameter synchronisation" before performing this operation.
 This function synchronises the parameters of the Master appliance on the Slave appliance(s) according to the tables in the Slave appliance menu.

 The parameter "Autodetect" is also used for the single appliance (Parag. 1.53). The remaining parameters, although visible in the single boiler menu, are used when the appliance is part of a simple cascade installation. For setting and explanation of the parameters, refer to the cascade booklet.

TECHNICIAN MENU/RESTORE SETTINGS

Menu item	Description
Restore settings	<p>Caution: Read and understand the device instructions before performing the reset operation. Press the 'OK' button (for about 3 s) to reset the settings, any other button to retain the current settings. N.B.: see the "Restore settings" column of "Technician menu" for each parameter that can be reset to factory settings or a set value. N.B.: the newly reset parameters are to be configured according to plant requirements. For simple cascade, please refer to the cascade booklet.</p>

TECHNICAL DATA



3.8 P.C.B. PROGRAMMING



For programming the circuit board, please refer to chapter 'Using the appliance' in the User section.



For password access, please refer to chapter "Technician menu".

3.9 CONVERTING THE APPLIANCE TO OTHER TYPES OF GAS



The gas conversion operation must be carried out by an authorised company (e.g. Authorised Technical Assistance Service).



The pressure testers used for calibration should be perfectly closed and there should be no leaks from the gas circuit.

If the appliance needs to be converted to a different gas type to that specified on the data plate, request the relative conversion kit for quick and easy conversion.

To convert to another type of gas the following operations are required:

- disconnect power to the appliance;
- replace the gas nozzle (detail 24 in fig. 59) positioned between the gas pipe and the gas-air mixing venturi, taking care to disconnect the appliance from the power supply during this operation;
- re-power the appliance;
- adjust the maximum heat output by varying the fan speed: parameter "Maximum speed";
- adjust the minimum heat output by varying the fan speed: parameter "Minimum speed";
- adjust the ignition heat output by varying the fan speed: parameter "Ignition speed";
- activate the chimney sweep function;
- check the value of CO₂/O₂ in particular:
 - check the CO₂/O₂ value in the flue with chimney sweep at 0%;
 - check the CO₂/O₂ value in the flue with chimney sweep at 100%;
- exit the chimney sweep function;
- seal the gas flow rate regulation devices (if settings are modified);
- after completing the conversion, apply the sticker, contained in the conversion kit, near the data nameplate. Using an indelible marker pen, delete the data relative to the old type of gas.

These adjustments must be made based on the type of gas used, following the indications provided in the tables in parag.4.1.

Checks following conversion to another type of gas.

After having made sure that the conversion is complete and that the calibration has been successful, you must make sure that:

- the burner flame is not too high or low and that it is stable (does not detach from burner);
- there are no leaks from the gas circuit.



Maintenance operations must be carried out by an authorised company (e.g. Authorised After-Sales Technical Assistance Centre).



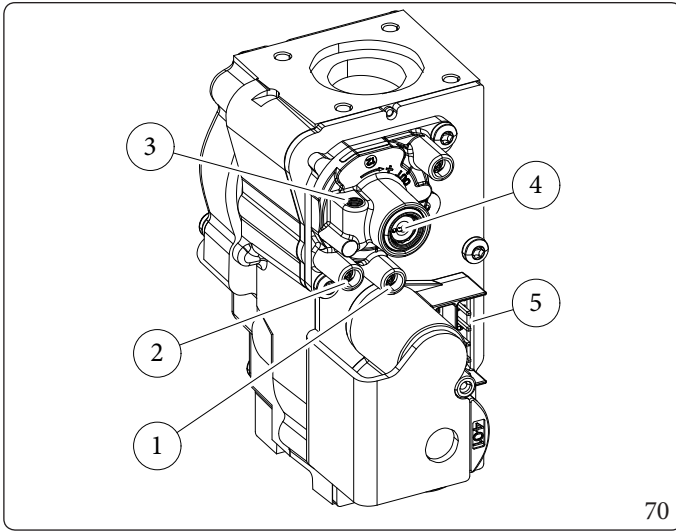

Honeywell Gas Valve (Rambler VK4405V)

Key (Fig. 70):

- 1 - Gas valve inlet pressure point
- 2 - Gas valve outlet pressure point
- 3 - Pressure feedback connection (PR)
- 4 - Offset adjustment screw (under the cap)
- 5 - Wiring connector

70



After 10 years from the date of manufacture, replace the gas valve.

Gas flow rate adjustment at maximum output (Venturi)

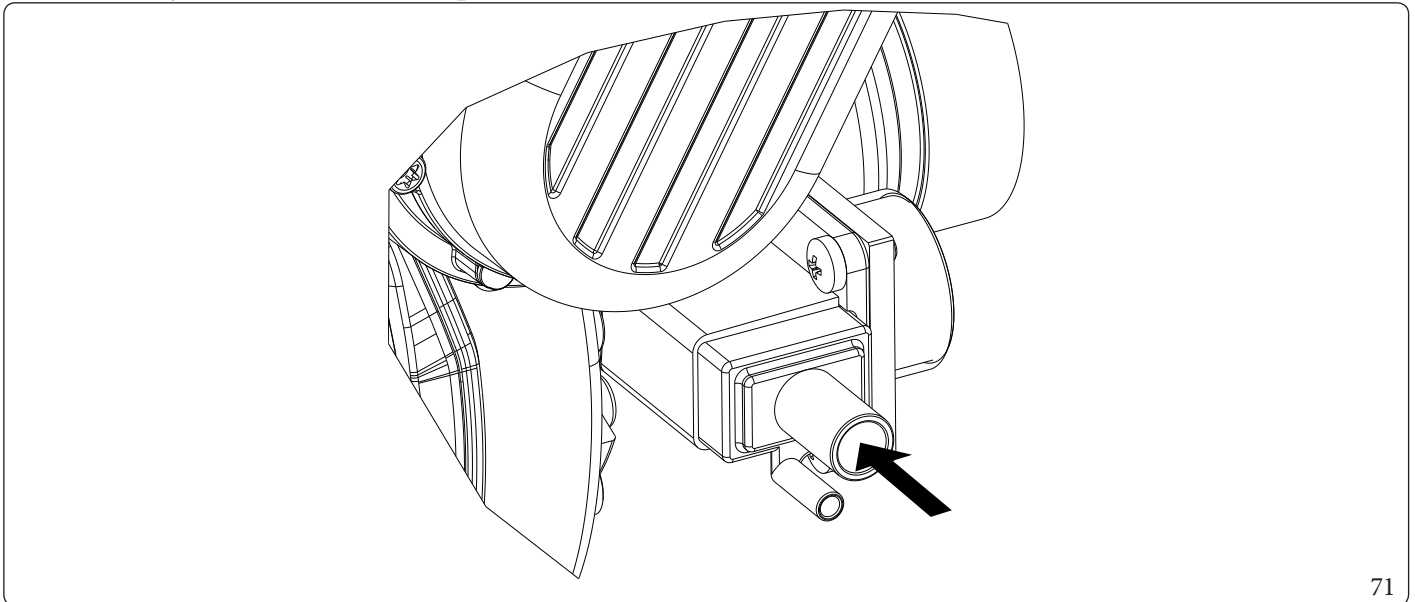

71



3.10 CO₂/O₂ REGULATION



To have an exact value of CO₂/O₂ in the flue, the technician must insert the sampling probe to the bottom of the sample point.



The verification operations of the CO₂/O₂ must be carried out with the casing mounted, while the gas valve calibration operations must be carried out with the casing open and removing the voltage from the appliance.



The calibrations described below must be carried out in the correct sequence and more precisely, first the calibration of the CO₂/O₂ at maximum output and then the calibration of the CO₂/O₂ at minimum output.

Calibration of the CO₂/O₂ at maximum output

Switch on the appliance and activate the chimney sweep function at minimum power (100 %); check that the CO₂/O₂ value is as indicated in the tables in par.4.2; if not, adjust the screw on the venturi (fig. 71) (gas flow rate adjustment). To increase the CO₂/O₂ value, turn the Venturi adjustment screw clockwise and vice versa to decrease it. At every adjustment on the Venturi screw it is necessary to wait for the boiler to stabilise itself at the value set (about 30 s).

Calibration of the CO₂/O₂ at minimum output

Once you have finished adjusting the maximum CO₂/O₂, switch on the appliance and activate the chimney sweep function at maximum power (0 %); check that the CO₂/O₂ value is as indicated in the tables in par.4.2; if not, adjust the screw under the cap (Ref. 4, fig. 70) (offset adjustment). To increase the CO₂/O₂ value, turn the adjustment screw (4) clockwise and vice versa to decrease it.



In the case where the calibration refers to O₂ the adjustment logic is reversed from the above for CO₂.



3.11 CHIMNEY SWEEP

This function, which can be activated at Technician menu/Manual test, allows the technician to check combustion parameters. The operating temperature is limited by the parameters "Zone 1 CH setpoint" and "Zone 2 CH setpoint". If the system-side sensor is used, the above two parameters limit the temperature on the hydraulic circuit where the system-side flow sensor is installed.



If the system-side flow probe is used, the temperature in the boiler (system-side flow control probe) is limited to the fixed value of 95°C.

The function is deactivated automatically after 30 minutes or manually by setting to 'OFF'. If the function is activated, it will be necessary to wait more than 30 seconds to reach the set power.

Figures 72, 73, show the images that appear by default when entering this function depending on whether it is an individual appliance or simple cascade.

Pressing the 'OK' button activates the function and visually displays the power percentage (which can be changed with the '+' and '-' buttons) limited by the function parameters "Maximum power" and "Minimum power" central heating.

In the case of cascade installation (fig. 73), it is possible to exclude one or more appliances from the "Chimney sweep" function: using the directional buttons "▲" and "▼" move to the appliance you want to exclude, press the "OK" button so that "OFF" appears.

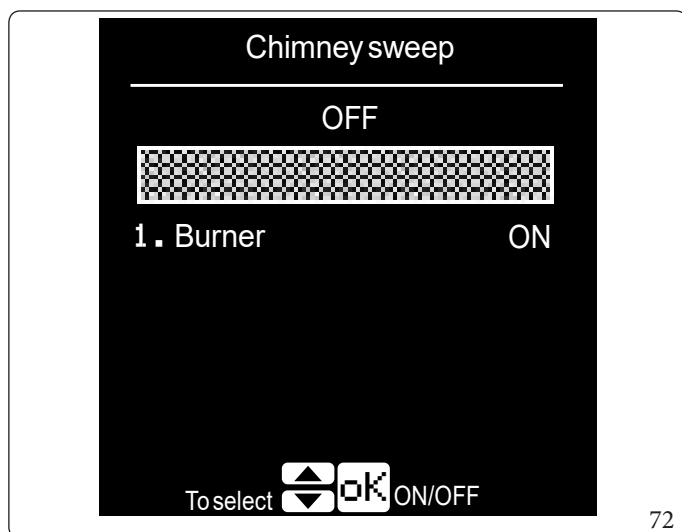

72

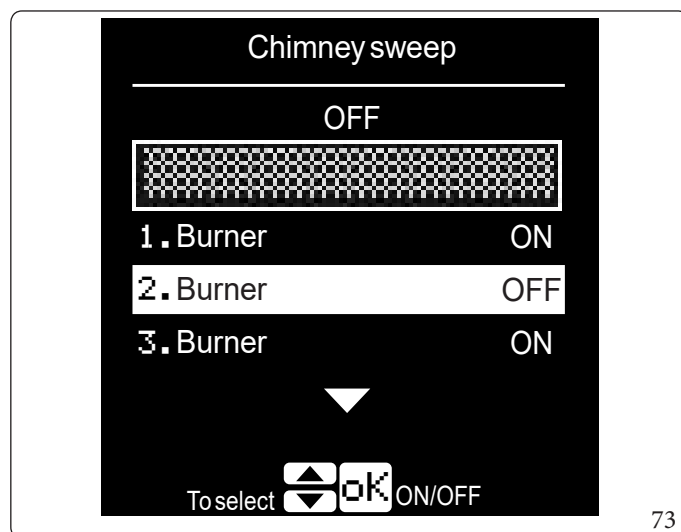

73

3.12 CH OUTPUT ADJUSTMENT

If it is necessary to change the heating output, the value of the parameters "Maximum power" and "Minimum power" in the "CH SETTINGS" menu must be adjusted, by entering the value in the table at par. 4.1 modulation column, for the gas used.

3.13 OUTPUT ADJUSTMENT DURING DHW (ONLY IN COMBINATION WITH AN OPTIONAL EXTERNAL STORAGE TANK)

If it is necessary to change the DHW output, the value of the parameters "Maximum power" and "Minimum power" in the "Domestic hot water" menu must be adjusted, by entering the value in the table at par. 4.1 modulation column, for the gas used.

3.14 PUMP ANTILOCK, 3-WAY VALVE AND MIXING VALVE (OPTIONALS)

The appliance is equipped with a function that starts the appliance pump and, if external pumps are connected, the 3-way valve and the mixing valve, at least once every 24 hours in order to reduce the risk of blockage due to prolonged inactivity.

3.15 ANTIFREEZE

i The antifreeze is also active when the appliance is in standby mode or when CH and/or DHW is disabled.

Radiators

The appliance is equipped with a function that starts the burner if the system flow water is below 9°C. The burner is switched off when the system flow water reaches approximately 35°C.

Depending on the hydraulic configurations and options installed, there may be additional antifreeze functions:

- **System sensor:** the burner is switched on when the temperature measured by the sensor falls below the parameter "System settings/Additional antifreeze protections/Antifreeze activation temperature" and is switched off when it reaches the value set in the parameter "System settings/Additional antifreeze protections/Antifreeze deactivation temperature".
- **Mixed probe:** the burner is switched on when the temperature measured by the probe falls below 3°C and is switched off above 15°C.
- **External sensor:** in this case the burner is not activated, but the pumps run (for activation of the various pumps, see paragraph 1.9 in the Installer chapter). Activation takes place when the temperature measured by the probe itself falls below the parameter "System settings/Additional antifreeze protections/Outside temperature pump activation" while switch-off occurs when the temperature exceeds the same parameter by 2°C.

i During the antifreeze function, the burner operates at minimum power (0%) so the parameter "Minimum power" is not considered.

DHW

Domestic hot water probe (optional): the burner is switched on when the temperature measured by the probe falls below 6°C and is switched off above 15°C.

i For the antifreeze function to work properly, the storage tank must be filled with water; otherwise, the antifreeze can operate continuously.

3.16 GASKET ASSEMBLY ON MANIFOLD

1. Place the module seal (1) on the manifold (2) as shown in Fig.74)



Every time the manifold is opened, the condition and integrity of the ceramic fibres must be verified and replaced, if necessary. Instead, the gasket (1) must be replaced every 2 years and whenever the manifold is opened, as required. After replacing the external silicone gasket (1), it is mandatory to check the flue gas tightness.

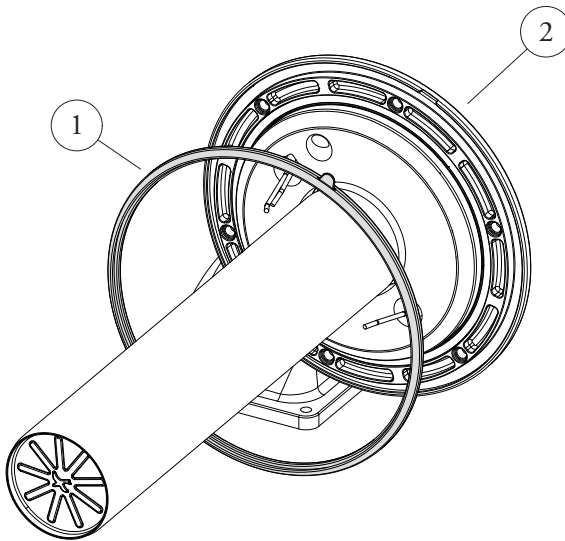

74

INSTALLER

USER

MAINTENANCE/TECHNICIAN

TECHNICAL DATA



3.17 ASSEMBLING THE MANIFOLD ON THE CONDENSATION MODULE



The maximum tightening force in assembling the manifold (2) on the condensation module (3) must be 7 Nm.

1. Set the manifold (2) on the module.
2. Tighten the 6 nuts (1) on the condensation module (3) according to the sequence (A, B, C, D, E, F) indicated in the drawing.

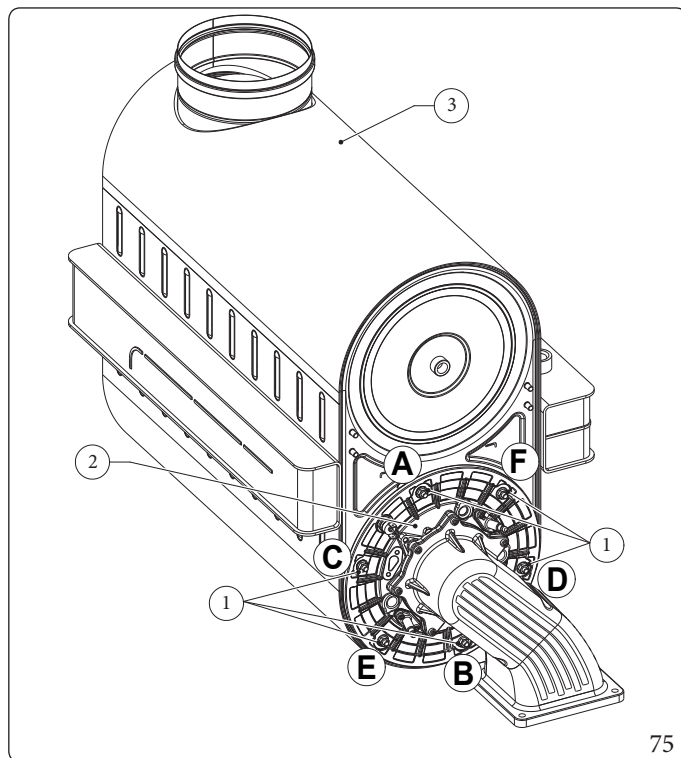

75

Electrode distance

To regain optimal operation, make sure that the following variables are respected when refitting the electrodes.

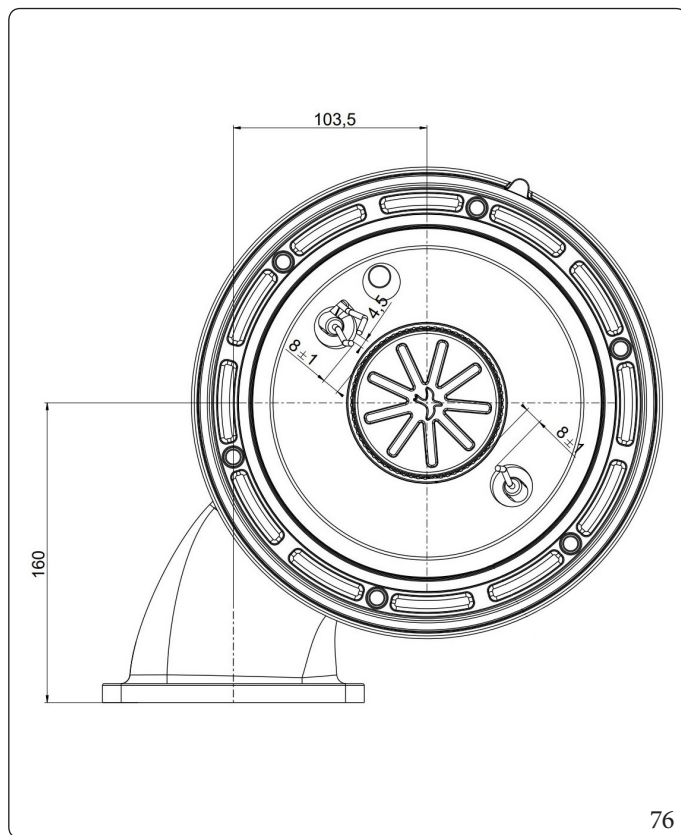

76



3.18 REPLACING THE MANIFOLD INSULATING PANEL

1. Unscrew the fixing screws (6) of the ignition and detection electrodes (5) and remove them.
2. Remove the insulating panel (1) by actuating a blade (2) under its surface.
3. Remove the residue of the fixing adhesive from the surface of the manifold (3).
4. Replace the insulating panel (1) using suitable sealant.
5. Refit the ignition and detection electrodes (5) using the previously removed screws (6) and replace the relative gaskets (4).

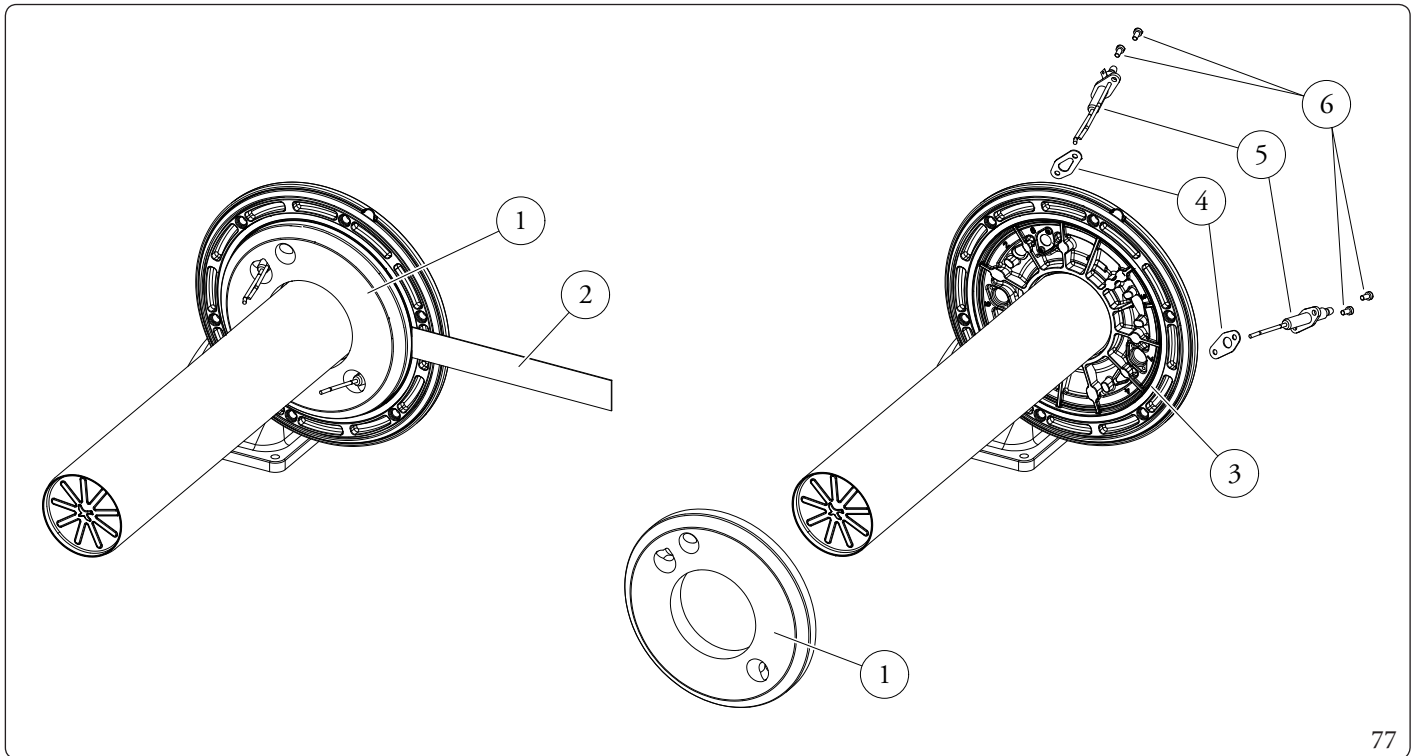

77

INSTALLER

USER

MAINTENANCE/TECHNICIAN

TECHNICAL DATA



3.19 CASINGREMOVAL

To facilitate appliance maintenance the casing can be completely removed as follows:

Front (Fig.78)

1. Loosen the two screws (a).
2. Pull the front casing (b) towards you.
3. Push the front casing upwards, releasing it from the upper pins (c).
4. Loosen the two screws (d).

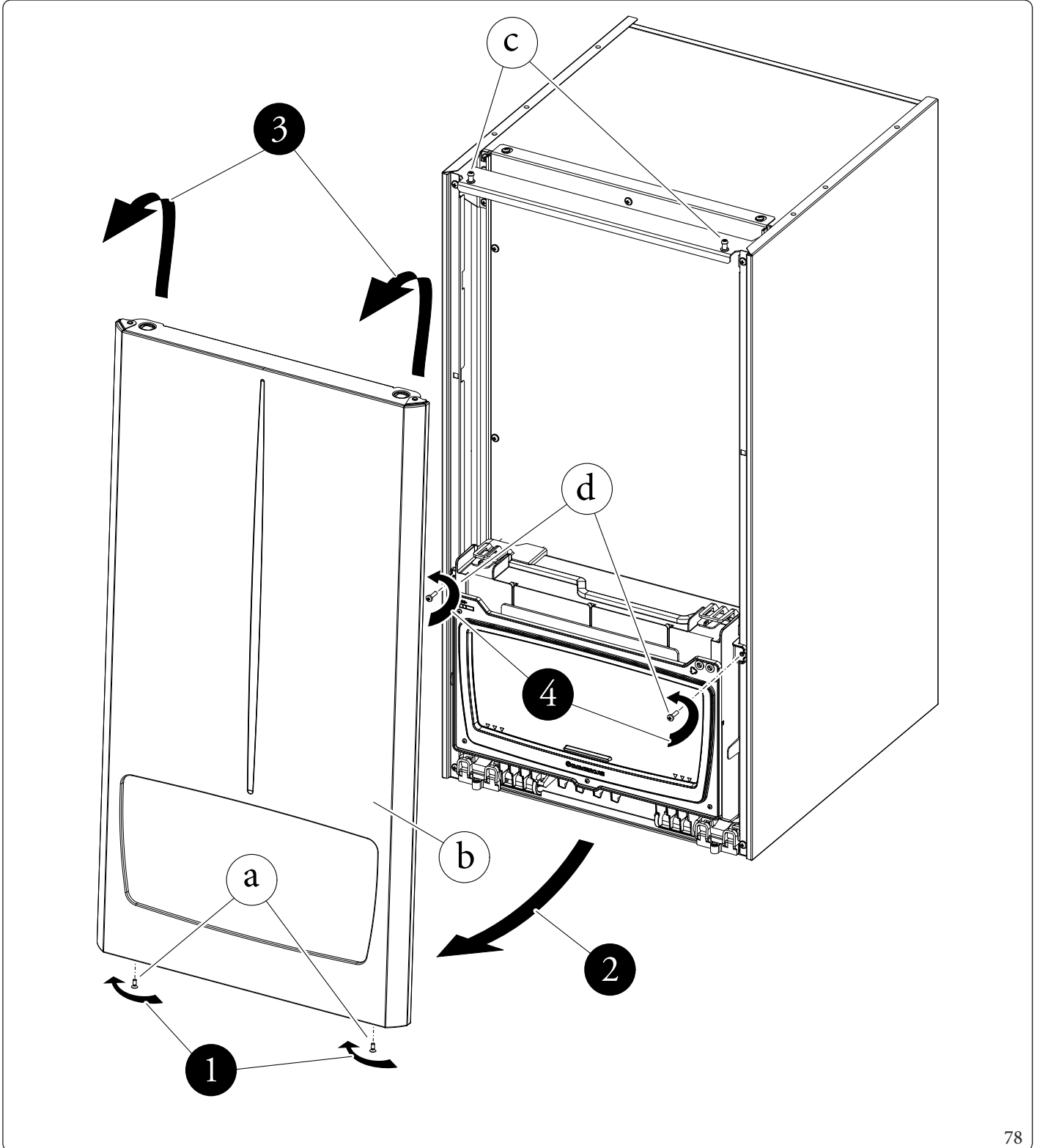

Sides (Fig. 78, 79)

5. Tilt the control panel (e) towards you.
6. Unscrew the four screws (f) in order to remove the lower grid (g).
7. Unscrew the four screws (h).
8. Remove the side panels (i) by opening them slightly outwards and then lifting them first upwards and then pulling them towards you, so that they disengage from the rear seats (Ref. X-Y).

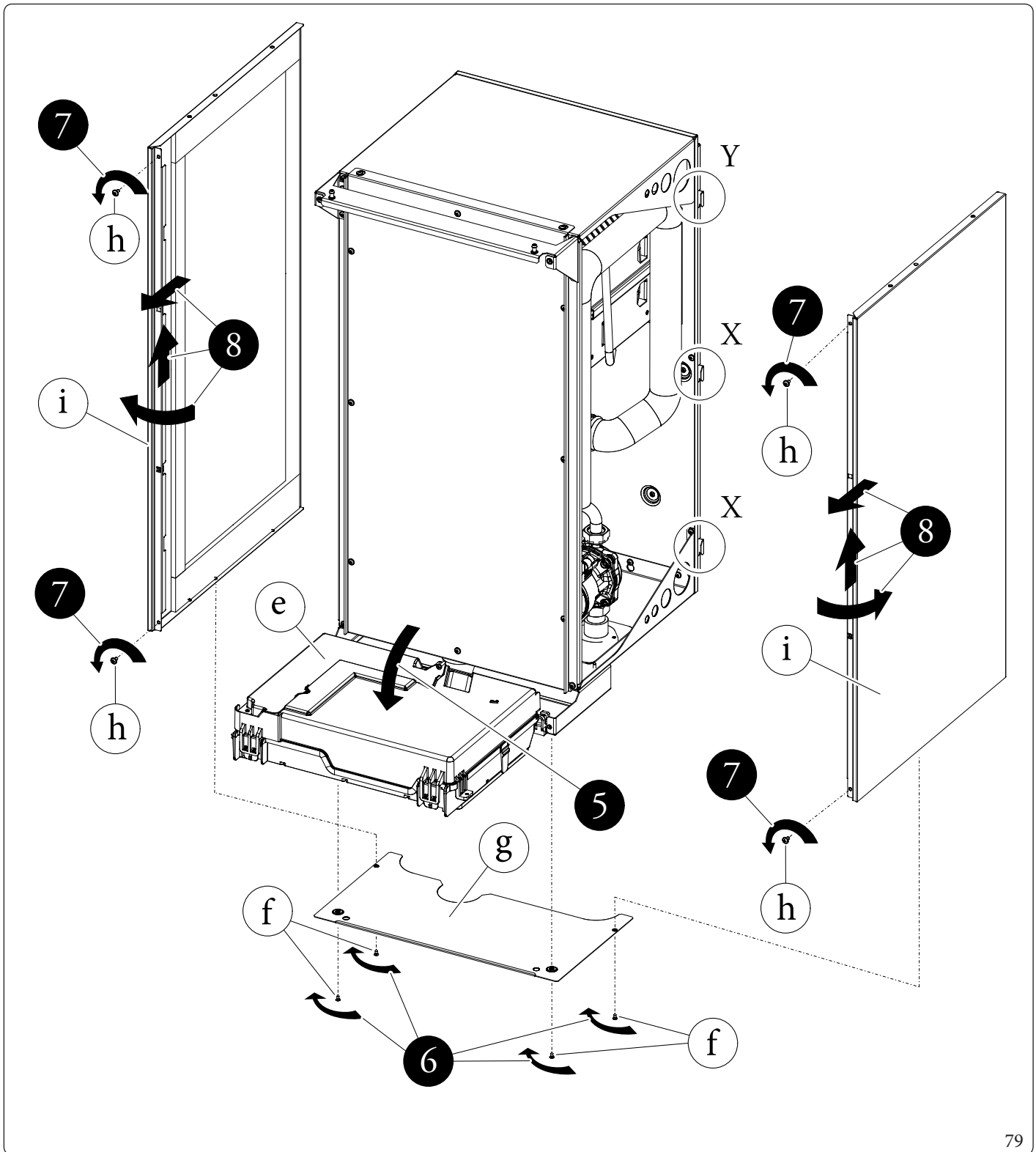

79

INSTALLER

USER

MAINTENANCE/TECHNICIAN

TECHNICAL DATA



Sealed chamber cover (Fig. 80)

9. Unscrew the eight screws (1).

10. Swing the airtight chamber cover (m) towards yourself so that it can be removed from the two rebated screws at the top of the frame and released.

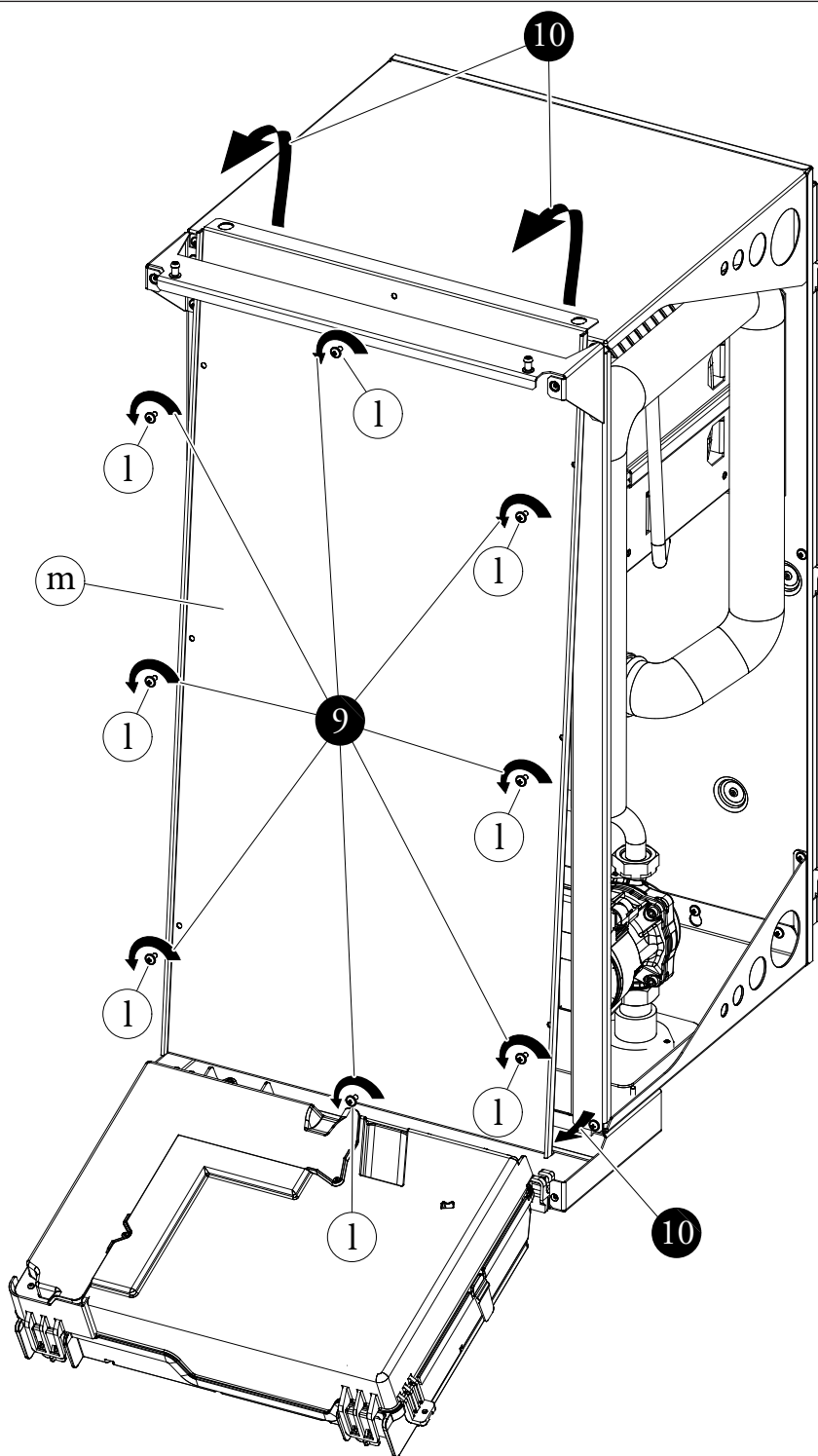

4 TECHNICAL DATA

4.1 VARIABLE HEAT OUTPUT



The power data in the table has been obtained with intake-exhaust pipe measuring 0.5 m in length. Gas flow rates refer to net calorific value below a temperature of 15°C and at a pressure of 1013 mbar.

FLOWRATE OUTPUT	HEAT OUTPUT	METHANE (G20)			PROPANE (G31)		
		FANREVS		GAS FLOWRATE BURNER	FANREVS		GAS FLOWRATE BURNER
		(kW)	(kW)	(rpm)	(%)	(m ³ /h)	(rpm)
170,0	166,9	5500	100	17,99	5000	100	13,21
161,5	158,6	5250	94	17,09	4750	93	12,55
153,0	150,2	5000	88	16,19	4550	88	11,89
144,5	141,9	4750	82	15,29	4300	81	11,23
136,0	133,6	4500	75	14,39	4100	75	10,57
127,5	125,2	4250	69	13,49	3850	68	9,90
119,5	117,3	4000	63	12,65	3650	63	9,28
111,0	109,0	3750	57	11,75	3450	57	8,62
102,4	100,5	3450	49	10,83	3200	50	7,95
94,0	92,2	3250	44	9,95	3000	44	7,30
85,5	83,8	2950	37	9,05	2750	38	6,64
77,0	75,4	2700	31	8,15	2550	32	5,98
68,5	67,0	2450	25	7,25	2300	25	5,32
60,0	58,7	2200	19	6,35	2050	18	4,66
51,5	50,3	1950	12	5,45	1850	13	4,00
43,0	42,0	1700	6	4,55	1600	6	3,34
34,7	33,8	1450	0	3,67	1400	0	2,70

INSTALLER

USER

MAINTENANCE TECHNICIAN

TECHNICAL DATA



4.2 COMBUSTION PARAMETERS

Combustion parameters: measuring conditions of useful efficiency (flow temperature/return temperature= 80/60 °C), ambient temperature reference = 20 °C.



When using H2NG mixtures with H₂ percentages up to 20% (referring to the gas distributed in the network), all calibration operations of the device must refer to the O₂ values of the gas G20 given in the following tables.

Gas type		G20	G31
Supply pressure	mbar	20,0	37,0
Gas nozzle diameter	mm	12,70	10,10
Ignition fan speed	rpm	2400	2600
Post ventilation fan speed	rpm	4000	4000
Flue flow rate at heating nominal heat output	kg/h	277	274
Flue flow rate at min heat output	kg/h	60	62
CO ₂ at Nominal Q.	%	9,1 (9,0 ÷ 9,4)	10,5 (10,4 ÷ 10,8)
O ₂ at Nominal Q.	%	4,6 (4,8 ÷ 4,1)	4,9 (5,0 ÷ 4,4)
CO ₂ at Minimum Q.	%	8,5 (8,2 ÷ 8,6)	9,3 (9,0 ÷ 9,4)
O ₂ at Minimum Q.	%	5,7 (6,2 ÷ 5,5)	- (- ÷ -)
CO with 0% O ₂ at Nom./Min. Q.	ppm	210 / 10	305 / 9
NO _x with 0% O ₂ at Nom./Min. Q.	mg/kWh	70 / 28	73 / 22
Flue temperature at nominal output	°C	72	71
Flue temperature at minimum output	°C	60	60



In addition to yearly maintenance, one must also check the energy efficiency of the thermal system, with frequency and procedures that comply with the indications of the technical regulations in force.

4.3 TECHNICAL DATA TABLE

		VICTRIX PRO V2 180 EU				
Central heating nominal heat input	kW	170,0				
Minimum heat input	kW	34,7				
PoCentral heating nominal heat input with 20%H ₂ NG gas	kW	160,6				
Minimum heat input with 20%H ₂ NG gas	kW	32,9				
Central heating nominal heat output (useful)	kW	166,9				
Minimum heat output (useful)	kW	33,8				
*Effective thermal efficiency 80/60 Nom./Min.	%	98,2/97,5				
*Effective thermal efficiency 50/30 Nom./Min.	%	106,0/ 108,2				
*Effective thermal efficiency 40/30 Nom./Min.	%	107,5/ 108,6				
Casing losses with burner On/Off (80-60°C)	W	306/ 170				
Chimney losses with burner On/Off (80-60°C)	W	31,0/2890				
Efficiency at 100% heat output (η_{100}) ref. UNIEN 15502-1	%	98,2				
Efficiency at partial heat load (η_{30}) ref. UNIEN 15502-1	%	108,4				
Central heating circuit max. operating pressure	bar	6,0				
Maximum heating temperature	°C	95				
Adjustable central heating temperature (min. operating field)	°C	15				
Adjustable central heating temperature (max operating field)	°C	90				
Appliance water content	l	15,0				
Head available with 1000l/h flow rate	kPa	-				
Weight of full boiler	kg	163,0				
Weight of empty boiler	kg	148,0				
Electrical connection	V/Hz	230/50				
Nominal absorbed current	A	2,8				
Installed electric power	W	520				
Equipment electrical system protection	IP	X5D				
Ambient operating temperature range	°C	-5 ÷ 40				
Ambient operating temperature range with optional antifreeze kit	°C	-15 ÷ 40				
NO _x class	-	6				
*Weighted NO _x G20	mg/kWh	42				
Weighted CO G20	mg/kWh	25				
Weighted NO _x G31	mg/kWh	34				
Weighted CO G31	mg/kWh	28				
Type of flue installation	-	B ₂₃ B _{23p} B ₃₃ B ₅₃ B _{53p} C ₁₃ C ₃₃ C ₄₃ C ₅₃ C ₆₃ C ₈₃ C _{13X} C _{33X} C _{43X} C _{53X} C _{63X} C _{83X}				
Market	IL	AL	IE	MK	MT	
Category	II2H3P Extra UE	II2H3P Extra UE	II2H3P	-	-	

* Efficiencies and weighted NO_x refer to the net calorific value.

For type C₆₃ it is forbidden to install the appliance as it came out of the factory, in configurations that require shared flues in positive pressure.

INSTALLER

USER

MAINTENANCE TECHNICIAN

TECHNICAL DATA



4.4 TECHNICAL PARAMETERS FOR COMBINATION BOILERS (IN COMPLIANCE WITH REGULATION 813/2013)

The efficiencies and NO_x values in the following tables refer to the gross calorific value.

Model	VICTRIX PRO V2 180 EU		
Condensing Boiler	YES		
Low temperature boiler	NO		
Boiler type B1	NO		
Co-generation appliance for central heating	NO		
Mixed heating appliance	NO		
Nominal heat output	P _n	167	kW
Seasonal energy efficiency of central heating	η _s	93	%
For central heating only and combination boilers: useful heat output			
At nominal heat output in high temperature mode (*)	P ₄	166,9	kW
At 30% of nominal heat output in a low temperature mode (**)	P ₁	56,0	kW
For central heating only and combination boilers: useful efficiency			
At nominal heat output in high temperature mode (*)	η ₄	88,4	%
At 30% of nominal heat output in a low temperature mode (**)	η ₁	97,6	%
Auxiliary electricity consumption			
At full load	e _{l_max}	0,068	kW
At partial load	e _{l_min}	0,021	kW
In standby mode	P _{SB}	0,006	kW
Other items			
Heat loss in standby	P _{stby}	0,139	kW
Ignition burner energy consumption	P _{ign}	0,000	kW
Emissions of nitrogen oxides	NO _x	38	mg\kWh
(*) High temperature mode means 60°C on return and 80°C on flow.			
(**) Low temperature mode for condensation Boilers means 30°C and for other appliances 50°C of return temperature.			

4.5 PRODUCT FICHE (IN COMPLIANCE WITH REGULATION 811/2013)

Parameter		Value
Annual energy consumption for the central heating mode (QHE)	Gj	311
Seasonal space heating energy efficiency (η_s)	%	93

For proper installation of the appliance refer to chapter 1 of this booklet (for the installer) and current installation regulations.

For proper maintenance refer to chapter 3 of this booklet (for the maintenance technician) and adhere to the frequencies and methods set out herein.

INSTALLER

USER

MAINTENANCE TECHNICIAN

TECHNICAL DATA



4.6 PARAMETERS FOR FILLING IN THE PACKAGE FICHE

If an assembly is to be made from this device, use the assembly sheets shown in (Fig. 82 and 84).

For the correct compilation, insert into the appropriate spaces (as shown in the facsimile package fiche (Fig. 81 and 83) the values set out in the tables "Parameters for compiling package fiche" and "Parameters for compiling DHW pack package fiche".

The remaining values must be obtained from the technical data sheets of the products used to make up the assembly (e.g. solar devices, integration heat pumps, temperature controllers).

Use sheet (Fig. 82) for "assemblies" related to the heating function (e.g.: boiler + temperature controller).

Use the sheet (Fig. 84) for 'sets' relating to the DHW function (when combined with a storage tank unit) (e.g.: storage tank unit + thermal solar).

Facsimile for filling in the package fiche for room central heating systems.

Seasonal central heating energy efficiency of the boiler ①
 %

Temperature control ②
 From temperature control board + %

Class I = 1 %, Class II = 2 %,
 Class III = 1.5 %, Class IV = 2 %,
 Class V = 3 %, Class VI = 4 %,
 Class VII = 3.5 %, Class VIII = 5 %

Supplementary boiler ③
 From boiler board = ± %

Seasonal central heating energy efficiency of the room (%)

(- 'I') x 0.1 = ±

Solar contribution ④
 From the board of the solar device = + %

Dimensions of the manifold (in m²) + 'IV' x
 Volume of the tank (in m³) (0.9 x (/ 100) x)
 Efficiency of the manifold (in %) x

Classification of the tank
 A* = 0.95, A = 0.91,
 B = 0.86, C = 0.83,
 D-G = 0.81

('III' x + 'IV' x) x (0.9 x (/ 100) x) = +

Supplementary heat pump ⑤
 From the heat pump board = + %

Seasonal central heating energy efficiency of the room (%)

(- 'I') x 'II' = +

Solar contribution and supplementary heat pump ⑥
 Select the lowest value = - %

0.5 x O 0.5 x

Seasonal central heating energy efficiency of the set ⑦
 %

Seasonal central heating energy efficiency class of the set

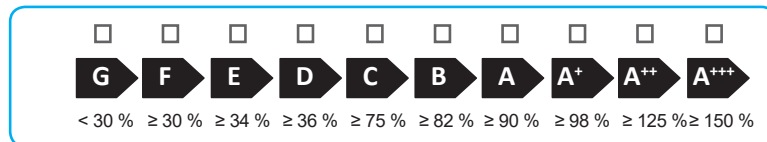

Boiler and supplementary heat pump installed with low temperature heat emitters at 35 °C?
 From the board of the heat pump ⑦
 + (50 x 'II') = %

The energy efficiency of the set of products indicated in this sheet may not reflect the actual energy efficiency after installation since such efficiency is affected by additional factors, such as the heat loss in the distribution system and the size of the products compared to the size and features of the building.

Parameters for filling in the assembly chart

Parameter	VICTRIXPRO V2 180 EU
"I"	93
"II"	*
"III"	0,16
"IV"	0,06

* to be established by means of table 5 of Regulation 811/2013 in case of "assembly" including a heat pump to integrate the boiler. In this case the boiler must be considered as the main appliance of the assembly.

Room central heating system package fiche.

Seasonal central heating energy efficiency of the boiler 1 %

Temperature control
From temperature control board

Class I = 1 %, Class II = 2 %,
 Class III = 1.5 %, Class IV = 2 %,
 Class V = 3 %, Class VI = 4 %,
 Class VII = 3.5 %, Class VIII = 5 %

2 %

Supplementary boiler
From boiler board

Seasonal central heating energy efficiency of the room (%)

(- _____) x 0.1 = ± 3 %

Solar contribution
From the board of the solar device

Dimensions of the manifold (in m²)

Volume of the tank (in m³)

Efficiency of the manifold (in %)

Classification of the tank
A* = 0.95, A = 0.91,
B = 0.86, C = 0.83,
D-G = 0.81

(_____ x + _____ x) x (0.9 x (/ 100) x = + 4 %

Supplementary heat pump
From the heat pump board

Seasonal central heating energy efficiency (in %)

(- _____) x _____ = + 5 %

Solar contribution and supplementary heat pump

Select the lowest value 0.5 x 4 O 0.5 x 5 = - 6 %

Seasonal central heating energy efficiency of the set 7 %

Seasonal central heating energy efficiency class of the set

G	F	E	D	C	B	A	A*	A**	A***
< 30 %	≥ 30 %	≥ 34 %	≥ 36 %	≥ 75 %	≥ 82 %	≥ 90 %	≥ 98 %	≥ 125 %	≥ 150 %

Boiler and supplementary heat pump installed with low temperature heat emitters at 35 °C?

From the board of the heat pump 7 + (50 x _____) = 8 %

The energy efficiency of the set of products indicated in this sheet may not reflect the actual energy efficiency after installation since such efficiency is affected by additional factors, such as the heat loss in the distribution system and the size of the products compared to the size and features of the building.

INSTALLER

USER

MAINTENANCE TECHNICIAN

TECHNICAL DATA

Facsimile for filling in the domestic hot water production system package fiche

Water heating energy efficiency of combination boiler

¹
 %

Stated load profile:

Solar contribution

From the board of the solar device

Auxiliary electricity

(1.1 x 'I' - 10 %) x 'II' - - 'I' = + %

Water heating energy efficiency of the assembly in average climate conditions

³
 %

Water heating energy efficiency class of the assembly in average climate conditions

	<input type="checkbox"/>	<input type="checkbox"/>	<input type="checkbox"/>	<input type="checkbox"/>	<input type="checkbox"/>	<input type="checkbox"/>	<input type="checkbox"/>	<input type="checkbox"/>	<input type="checkbox"/>	<input type="checkbox"/>
	G	F	E	D	C	B	A	A⁺	A⁺⁺	A⁺⁺⁺
<input type="checkbox"/> M	< 27 %	≥ 27 %	≥ 30 %	≥ 33 %	≥ 36 %	≥ 39 %	≥ 65 %	≥ 100 %	≥ 130 %	≥ 163 %
<input type="checkbox"/> L	< 27 %	≥ 27 %	≥ 30 %	≥ 34 %	≥ 37 %	≥ 50 %	≥ 75 %	≥ 115 %	≥ 150 %	≥ 188 %
<input type="checkbox"/> XL	< 27 %	≥ 27 %	≥ 30 %	≥ 35 %	≥ 38 %	≥ 55 %	≥ 80 %	≥ 123 %	≥ 160 %	≥ 200 %
<input type="checkbox"/> XXL	< 28 %	≥ 28 %	≥ 32 %	≥ 36 %	≥ 40 %	≥ 60 %	≥ 85 %	≥ 131 %	≥ 170 %	≥ 213 %

Water heating energy efficiency class in colder and hotter climate conditions

Colder: - 0.2 x = %

Hotter: + 0.4 x = %

The energy efficiency of the set of products indicated in this sheet may not reflect the actual energy efficiency after installation since such efficiency is affected by additional factors, such as the heat loss in the distribution system and the size of the products compared to the size and features of the building.



Parameters for filling in the DHW package fiche

Parameter	VICTRIXPRO V2 180 EU
"I"	-
"II"	*
"III"	*

* to be determined according to Regulation 811/2013 and transient calculation methods as per Notice of the European Community no. 207/2014.

Domestic hot water production system package fiche.

Water heating energy efficiency of combination boiler %

Stated load profile:

Solar contribution

From the board of the solar device

Auxiliary electricity

(1.1 x - 10 %) x - = + %

Water heating energy efficiency of the assembly in average climate conditions %

Water heating energy efficiency class of the assembly in average climate conditions

	<input type="checkbox"/>	<input type="checkbox"/>	<input type="checkbox"/>	<input type="checkbox"/>	<input type="checkbox"/>	<input type="checkbox"/>	<input type="checkbox"/>	<input type="checkbox"/>	<input type="checkbox"/>	<input type="checkbox"/>
	G	F	E	D	C	B	A	A ⁺	A ⁺⁺	A ⁺⁺⁺
<input type="checkbox"/> M	< 27 %	≥ 27 %	≥ 30 %	≥ 33 %	≥ 36 %	≥ 39 %	≥ 65 %	≥ 100 %	≥ 130 %	≥ 163 %
<input type="checkbox"/> L	< 27 %	≥ 27 %	≥ 30 %	≥ 34 %	≥ 37 %	≥ 50 %	≥ 75 %	≥ 115 %	≥ 150 %	≥ 188 %
<input type="checkbox"/> XL	< 27 %	≥ 27 %	≥ 30 %	≥ 35 %	≥ 38 %	≥ 55 %	≥ 80 %	≥ 123 %	≥ 160 %	≥ 200 %
<input type="checkbox"/> XXL	< 28 %	≥ 28 %	≥ 32 %	≥ 36 %	≥ 40 %	≥ 60 %	≥ 85 %	≥ 131 %	≥ 170 %	≥ 213 %

Water heating energy efficiency class in colder and hotter climate conditions

Colder: - 0.2 x = %

Hotter: + 0.4 x = %

The energy efficiency of the set of products indicated in this sheet may not reflect the actual energy efficiency after installation since such efficiency is affected by additional factors, such as the heat loss in the distribution system and the size of the products compared to the size and features of the building.







Immergas S.p.A.

42041 Brescello (RE) - Italy

Tel. 0522.689011

immergas.com



IMMERGAS

IMMERGASPA-ITALY
CERTIFIED COMPANY
UNI EN ISO 9001:2015

Design, manufacture and post-sale
assistance of gas boilers, gas water heaters
and related accessories



This instruction booklet is made of
ecological paper.

