

VICTRIX OMNIA V2

EE IE

Instructions and recommendations

Installer

User

Maintenance technician

Technical Data

1.047702ENG

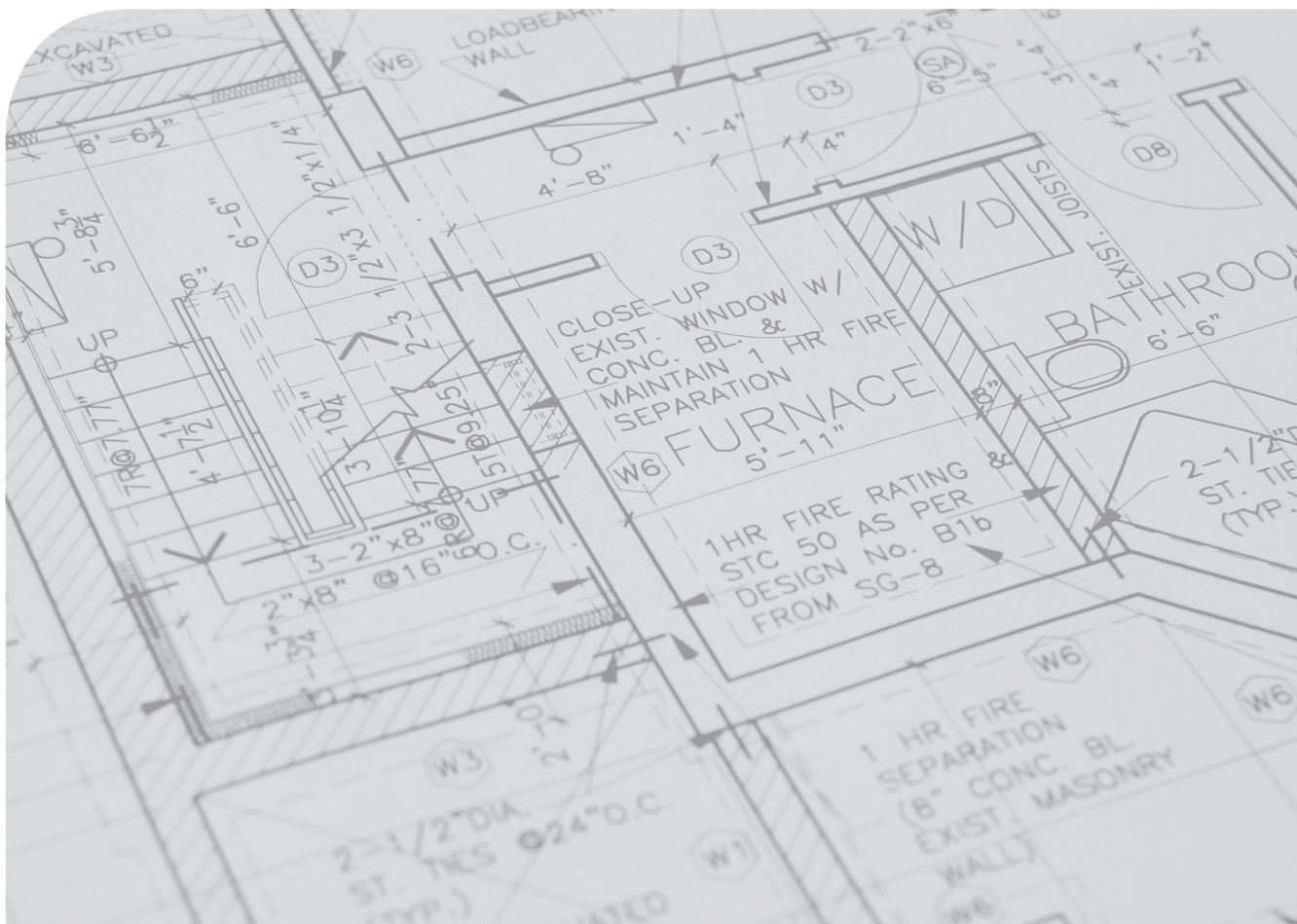

INDEX

Dear Customer.....	4
General Recommendations.....	4
Safety symbols used.....	6
Personal protective equipment	6
1 Unit installation	7
1.1 Installation warnings	7
1.2 Data nameplate and installation information sticker	11
1.2.1 Data nameplate positioning.....	11
1.2.2 Key for data nameplate.....	12
1.2.3 Installation information sticker	12
1.3 Main dimensions	13
1.4 Minimum installation distances.....	14
1.5 Antifreeze protection	15
1.6 Installation inside the recessed frame (Optional).....	16
1.7 Appliance connection unit (Optional)	17
1.8 Gas connection.....	18
1.9 Hydraulic connection.....	19
1.10 Electrical connection.....	20
1.11 Remote controls and room chrono-thermostats (Optional)	22
1.12 External temperature probe (Optional).....	23
1.13 General examples of types of installation of flue systems	24
1.14 Immergas flue systems.....	25
1.15 Maximum flue length	27
1.16 Equivalent lengths of "Green Range" flue system components.....	28
1.17 Outdoor installation or in a partially protected area	34
1.18 Internal installation using a recessed frame with direct air intake	36
1.19 Concentric horizontal kit installation	37
1.20 Concentric vertical kit installation	41
1.21 Installation of vertical terminals Ø 80.....	46
1.22 Separator kit installation.....	47
1.23 Adaptor kit installation C ₉	50
1.24 Ducting of flues or technical slots	52
1.25 Configuration C ₍₁₅₎₃ concentric kit	53
1.26 Configuration C ₍₁₀₎₃ concentric kit (Ø 80/125).....	54
1.27 Configuration C ₍₁₀₎₃ - C ₍₁₂₎₃ separator kit (Ø 80/80).....	57
1.28 Configuration for C ₆ flue installation.....	63
1.29 Configuration type B, open chamber and fan assisted for indoors	64
1.30 Flue exhaust to flue/chimney.....	64
1.31 Flues, chimneys and chimney caps.	65
1.32 Water treatment plant filling.....	66
1.33 System filling	67
1.34 Filling the condensate drain trap.....	67
1.35 Gas system start-up.....	67
1.36 Appliance start-up (Ignition).....	68
1.37 UPM3 circulation pump	69
1.38 UPM4 circulation pump.....	70
1.39 Kits available on request	71
1.40 Main components	72
2 Instructions for use and maintenance	73
2.1 General recommendations	73
2.2 Cleaning and maintenance	75



2.3	Control panel	75
2.4	Using the appliance	75
2.5	Fault and anomaly signals	77
2.6	Parameters and information menu	82
2.7	Appliance switch-off	83
2.8	Restore central heating system pressure	83
2.9	Draining the system	83
2.10	Emptying the D.H.W. circuit	83
2.11	Antifreeze protection	83
2.12	Prolonged inactivity	83
2.13	Cleaning the case	83
2.14	Permanent shutdown	84
3	Instructions for maintenance and initial check	85
3.1	General recommendations	85
3.2	Initial check	86
3.3	Yearly appliance check and maintenance	87
3.4	Hydraulic diagram	89
3.5	Wiring diagram	90
3.6	Troubleshooting	92
3.7	Converting the appliance to other types of gas	93
3.8	Calibration type involving the replacement of a component	94
3.9	Complete calibration	94
3.10	CO ₂ adjustment	97
3.11	Quick calibration	98
3.12	Flue test	100
3.13	P.C.B. programming	101
3.14	Solar panels coupling	106
3.15	Chimney sweep	106
3.16	Pump anti-block	106
3.17	Three-way anti-block	106
3.18	Radiator antifreeze	106
3.19	P.C.B. periodical self-check	106
3.20	Automatic vent	107
3.21	Screed heater	107
3.22	Casing removal	108
4	Technical data	109
4.1	Variable heat output	109
4.2	Combustion parameters	110
4.3	Technical data table	111
4.4	Technical parameters for combination boilers (in compliance with Regulation 813/2013)	112
4.5	Product fiche (in compliance with Regulation 811/2013)	113
4.6	Parameters for filling in the package fiche	114



Dear Customer

Congratulations for having chosen a top-quality Immergas product, able to assure well-being and safety for a long period of time. As an Immergas customer you can also count on a Qualified Authorised After-Sales Technical Assistance Centre, prepared and updated to guarantee the constant efficiency of your products. Read the following pages carefully: you will be able to draw useful tips on the proper use of the device, compliance with which will confirm your satisfaction with the Immergas product.

For assistance and routine maintenance, contact Authorised Technical Service Centres: they have original spare parts and are specifically trained directly by the manufacturer.



GENERAL RECOMMENDATIONS

This book contains important information for the:

Installer (section 1);

User (section 2);

Maintenance Technician (section 3).

- The user must carefully read the instructions in the specific section (section 2).
- The user must limit operations on the appliance only to those explicitly allowed in the specific section.
- The appliance must be installed by qualified and professionally trained personnel.
- The instruction booklet is an integral and essential part of the product and must be given to the new user in the case of transfer or succession of ownership.
- It must be stored with care and consulted carefully, as all of the warnings provide important safety indications for installation, use and maintenance stages.
- In compliance with the legislation in force, the systems must be designed by qualified professionals, within the dimensional limits established by the Law. Installation and maintenance must be performed in compliance with the regulations in force, according to the manufacturer's instructions and by professionally qualified staff, meaning staff with specific technical skills in the plant sector, as provided for by Law.
- Improper installation or assembly of the Immergas device and/or components, accessories, kits and devices can cause unexpected problems for people, animals and objects. Read the instructions provided with the product carefully to ensure proper installation.
- This instructions manual provides technical information for installing Immergas products. As for the other issues related to the installation of products (e.g. safety at the workplace, environmental protection, accident prevention), it is necessary to comply with the provisions of the standards in force and the principles of good practice.
- All Immergas products are protected with suitable transport packaging.
- The material must be stored in a dry place protected from the weather.
- Damaged products must not be installed.
- Maintenance must be carried out by skilled technical staff. For example, the Authorised Service Centre that represents a guarantee of qualifications and professionalism.
- The appliance must only be destined for the use for which it has been expressly declared. Any other use will be considered improper and therefore potentially dangerous.
- If errors occur during installation, operation and maintenance, due to non-compliance with technical laws in force, standards or instructions contained in this booklet (or however supplied by the manufacturer), the manufacturer is excluded from any contractual and extra-contractual liability for any damages and the device warranty is invalidated.
- In the event of malfunctions, faults or incorrect operation, turn the appliance off and contact an authorised company (e.g. the Authorised Technical Assistance Centre, which has specifically trained staff and original spare parts). Do not attempt to modify or repair the appliance alone.



IMPORTANT

The company **IMMERGAS S.p.A.**, with registered office in via Cisa Ligure 95 42041 Brescello (RE), declares that the design, manufacturing and after-sales assistance processes comply with the requirements of standard **UNIENISO 9001:2015**.

For further details on the product CE marking, request a copy of the Declaration of Conformity from the manufacturer, specifying the appliance model and the language of the country.

The manufacturer declines all liability due to printing or transcription errors, reserving the right to make any modifications to its technical and commercial documents without forewarning.



SAFETY SYMBOLS USED



GENERIC HAZARD

Strictly follow all of the indications next to the pictogram. Failure to follow the indications can generate hazard situations resulting in possible harm to the health of the operator and user in general, and/or property damage.



ELECTRICAL HAZARD

Strictly follow all of the indications next to the pictogram. The symbol indicates the appliance's electrical components or, in this manual, identifies actions that can cause an electrical hazard.



MOVING PARTS

The symbol indicates the appliance's moving components that can cause hazards.



DANGER OF HOT SURFACES

The symbol indicates the appliance's very hot components that can cause burns.



WARNINGS

Strictly follow all of the indications next to the pictogram. Failure to follow the indications can generate hazard situations resulting in possible minor injuries to the health of both the operator and the user in general, and/or slight material damage.



ATTENTION

Read and understand the instructions of the appliance before carrying out any operation, carefully following the instructions given. Failure to observe the instructions may result in malfunction of the unit.



INFORMATION

Indicates useful tips or additional information.



EARTH TERMINAL CONNECTION

The symbol identifies the appliance's earth terminal connection point.



DISPOSAL WARNING

The user must not dispose of the appliance at the end of its service life as municipal waste, but send it to appropriate collection centres.

PERSONAL PROTECTIVE EQUIPMENT



SAFETY GLOVES



EYE PROTECTION



SAFETY FOOTWEAR



1 UNIT INSTALLATION

1.1 INSTALLATION WARNINGS



Operators who install and service the appliance must wear the suitable personal protective equipment required by applicable law.



This appliance has been designed for wall mounted installation only, for central heating and production of domestic hot water for domestic use and similar purposes.



The place of installation of the appliance and relative Immergas accessories must have suitable features (technical and structural), such as to allow for (always in safe, efficient and comfortable conditions):

- installation (according to the provisions of technical legislation and technical regulations);
- maintenance operations (including scheduled, periodic, routine and special maintenance);
- removal (to outdoors in the place for loading and transporting the appliances and components) as well as the eventual replacement of those with appliances and/or equivalent components.



The wall surface must be smooth, without any protrusions or recesses enabling access to the rear part. They are not designed to be installed on plinths or floors (Fig. 1).



By varying the type of installation the classification of the appliance and precisely:

- **Type B₂₃ or B₅₃** appliance if installed using the relevant terminals for air intake directly from the room in which the appliance has been installed.
- **Type C appliance** if installed using concentric pipes or other types of pipes envisioned for the sealed chamber appliance for intake of air and expulsion of flue gas.



Only professionally enabled companies are authorised to install Immergas gas appliances.



Installation must be carried out according to regulation standards, current legislation and in compliance with local technical regulations and the required technical procedures.



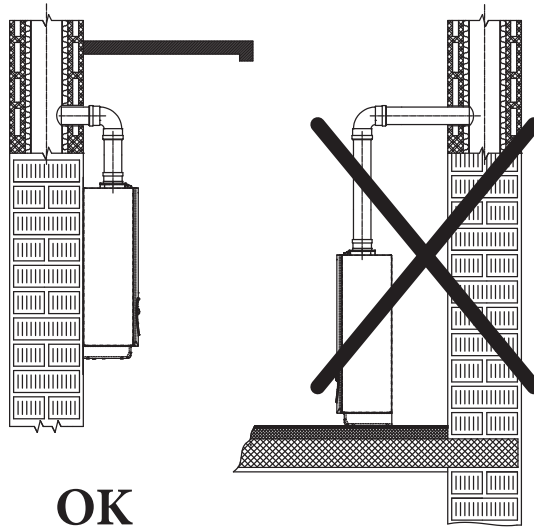

OK

1



It is not permitted to install boilers that are removed and decommissioned from other systems. The manufacturer declines all liability in the event of damage caused by appliances removed from other systems or for any non-conformities with such equipment.



Check the environmental operating conditions of all parts relevant to installation, referring to the values shown in the technical data table in this booklet.



Installation of the appliance when powered by LPG or propane air must comply with the rules regarding gases with a greater density than air (remember, as an example, that it is prohibited to install plants powered with the above-mentioned gas in rooms where the floor is at a lower quota than the country level).



If installing a kit or servicing the appliance, always empty the system's domestic hot water circuit first so as not to compromise the appliance's electrical safety (Par. 2.9, 2.10). Always disconnect the appliance from voltage and, depending on the type of operation, decrease the pressure and/or bring it to zero in the gas and DHW circuits.



If the appliance is connected to a low temperature direct zone, it is necessary to check the necessary flow rate and possibly add a relaunch pump.



Packing materials (staples, nails, plastic bags, polystyrene foam, etc.) constitute a hazard and must be kept out of the reach of children. If the appliance is installed inside or between cabinets, ensure sufficient space for routine servicing; for minimum installation distances, see Fig. 6. Before installing the appliance, ensure that it is delivered in perfect condition; if in doubt, contact the supplier immediately.



It is just as important that the intake grids and exhaust terminals are not obstructed.



Check that no flue gas recirculation is found in the air sample points. Allow the appliance to reach the maximum heat output; the CO₂ value measured in the air must be less than 10% of that measured on the flue gas.



 Keep all combustible material away from the appliance (paper, rags, plastic, polystyrene, etc.).

 The minimum distance for exhaust pipes from flammable materials must be at least 25 cm.

 Do not place household appliances underneath the appliance as they could be damaged if the safety valve intervenes, if the drain trap is blocked, or if there are leaks from the hydraulic connections; otherwise, the manufacturer cannot be held responsible for any damage caused to the household appliances.

 For the aforementioned reasons, we recommend not placing furnishings, furniture, etc. under the appliance.

 Any modification to the appliance that is not explicitly indicated in this section of the booklet is forbidden.

Installation standards

 This appliance can be installed outdoors in a partially protected area.
By partially protected area, we mean one in which the unit is not directly exposed to the elements (rain, snow, hail, etc.).

 This type of installation is possible when permitted by the laws in force in the appliance's country of destination.

 **Installation of gas appliances, flue exhaust pipes and combustion air intake pipes is forbidden in places with a fire risk (for example: garages, closed parking stalls), and in potentially dangerous places.**

 **Do not install on the vertical projection of hobs.**

 **Do not install in places/rooms that constitute public areas of apartment buildings, internal stairways or other escape routes (e.g. floor landings, entrance halls, etc.).**

 **Installation is also forbidden in places/rooms that constitute public areas of apartment buildings such as cellars, entrance halls, attics, lofts, etc., unless otherwise provided for by local regulations in force.**

 **These appliances, if not adequately isolated, are not suitable for installation on walls of combustible material.**

 Installing the wall recessed frame kit must guarantee the boiler stable, efficient support.

The recessed frame kit ensures appropriate support only if installed correctly (according to the rules of good practice), following the instructions on its instructions leaflet.

The recessed frame for the boiler is not a supporting structure and must not replace the wall removed. It is necessary to position the boiler inside the wall.



For safety reasons against any leaks it is necessary to plaster the boiler housing in the brick wall.



Wall mounting of the appliance must guarantee stable and efficient support for the generator.

The plugs (standard supply) that come with the appliance are only to be used to fix the latter to the wall; they only ensure adequate support if inserted correctly (according to technical standards) in walls made of solid or semi-hollow brick or block. In the case of walls made from hollow brick or block, partitions with limited static properties, or in any case walls other than those indicated, a static test must be carried out to ensure adequate mount. Appliances must be installed in such a way as to avoid knocks or tampering.



These appliances are used to heat water to below boiling temperature in atmospheric pressure.



They must be connected to a central heating system and domestic hot water circuit suited to their performance and capacity.

Risk of damage due to corrosion caused by unsuitable combustion air and environment.



Spray, solvents, chlorine-based detergents, paints, glue, ammonium compounds, powders and similar cause product and flue duct corrosion.



Check that combustion air power supply is free from chlorine, sulphur, powders, etc.



Make sure that no chemical substances are stored in the place of installation.



If you want to install the product in beauty salons, paint workshops, carpenter's shop, cleaning companies or similar, choose a separate installation area that ensures combustion air supply that is free from chemical substances.



Make sure the combustion air is not fed through chimneys that were previously used with boilers or other central heating appliances powered by liquid or solid fuels. In fact, these may cause an accumulation of soot in the chimney

Risk of material damage after using sprays and liquids to search for leaks



Leak sprays and liquids clog the reference hole P.Ref. (Fig. 64) of the gas valve, damaging it irreparably. During installation and maintenance, do not use spray or liquids on the gas valve (electric connections side).

Filling the condensate drain trap



When the appliance is switched on for the first time, combustion products come out of the condensate drain. After a few minutes of operation, check that combustion flue gases are no longer coming out of the condensate drain; this means that the drain trap has filled to a correct condensate height that the flue gases cannot pass through.



Open chamber appliances type B₂₃ and B₅₃ must not be installed in rooms in which commercial, craft or industrial activities are carried out where products are used that are capable of developing vapours or volatile substances (e.g. acid vapours, glues, paints, solvents, fuels, etc.), as well as dust (e.g. dust from wood processing, coal dust, cement dust, etc.) that could be harmful to the appliance's components and impair its operation.



In configuration B₂₃ and B₅₃, unless local regulations are in force, the appliances must not be installed in bedrooms, bathrooms, toilets or studios; they must neither be installed in rooms containing solid fuel heat generators nor in rooms communicating with said rooms.



The installation rooms must be permanently ventilated, in compliance with the local regulations in force (at least 6 cm² for every kW of installed heat input, except in the event of any increases needed for electro-mechanical vacuum cleaners or other devices that could put the installation room under vacuum).



Install the appliances in B₂₃ and B₅₃ configuration in non-residential premises and which are permanently ventilated.



Failure to comply with the above implies personal responsibility and invalidates the warranty.

1.2 DATA NAMEPLATE AND INSTALLATION INFORMATION STICKER

1.2.1 Data nameplate positioning

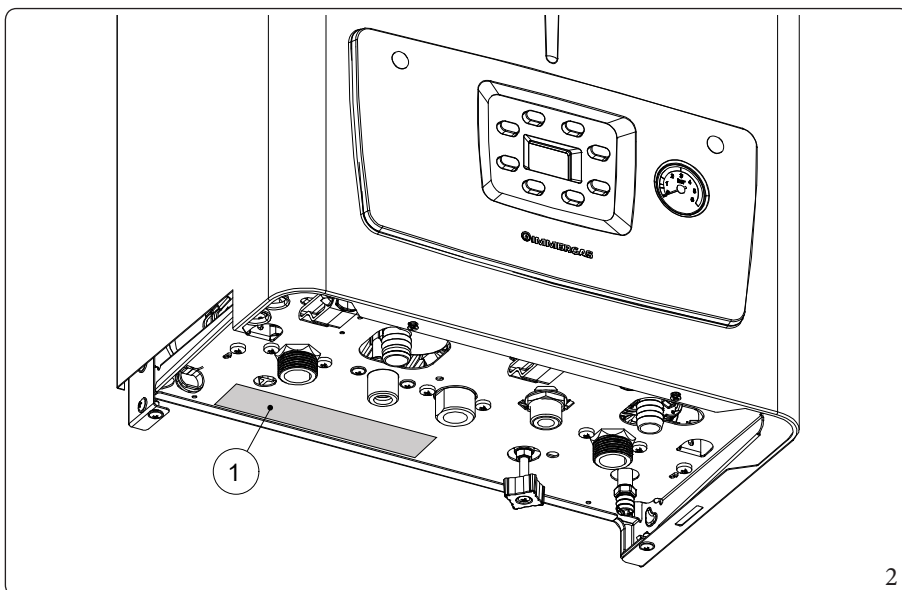

Key (Fig. 2):

1 - Data plate



1.2.2 Key for data nameplate

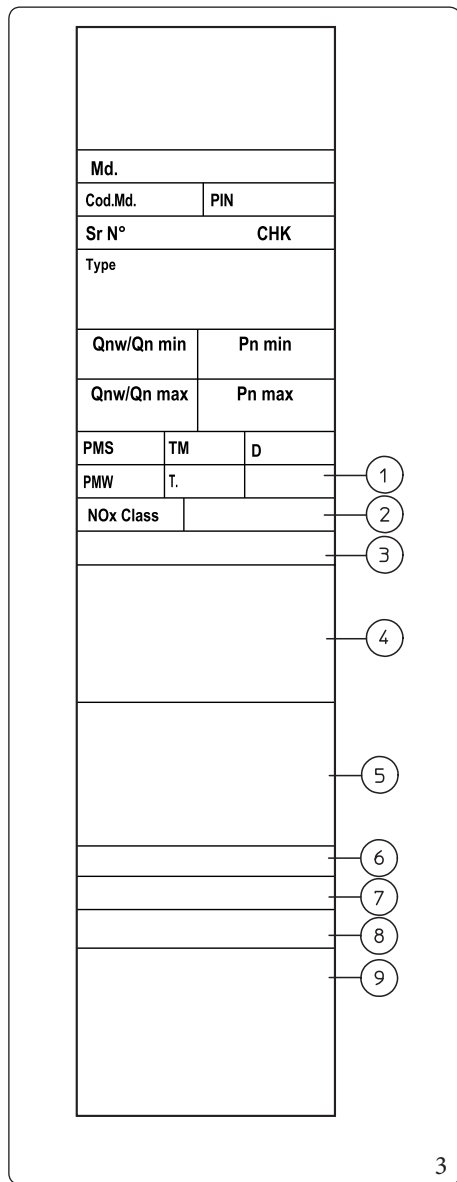

	ENG
Md.	Model
Cod.Md.	Model code
PIN	PIN code
Sr N°	Serial Number
CHK	Check
Type	Type of installation (ref. UNI EN 1749)
Qnw min	Minimum DHW heat input
Qn min	Central heating minimum heat input
Pn min	Minimum heat output
Qnw max	DHW maximum heat input
Qn max	Central heating maximum heat input
Pn max	Maximum heat output
PMS	Maximum system pressure
TM	Maximum operating temperature
D	Specific flow rate
PMW	Maximum domestic hot water pressure
T.	Minimum and maximum installation temperature
1	IP protection rating
NOx Class	NOx Class
2	Rated voltage - Power supply symbol - Rated frequency - Rated output (Absorption)
3(*)	Maximum additional absorption of kits that can be installed (to be added to the Rated output)
4	Logos and markings
5	Gas categories and countries of destination
6(*)	Specific information for Belgium
7	Factory calibration
8(*)	Hydrogen ready
9	Type of appliance

(*) = if present.



The technical data are provided on the data plate on the appliance.

1.2.3 Installation information sticker

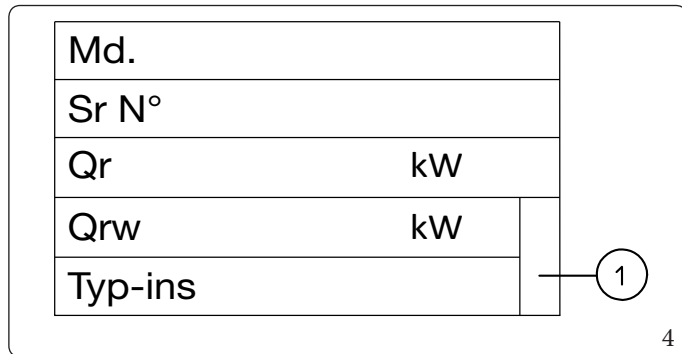

	ENG
Md.	Model
Sr N°	Serial Number
Qr	Central heating output set
Qrw	DHW output set
Typ-ins	Type of flue installed
1	Adhesive item code



At the time of installation, the authorised technician must fill in the facsimile of the installation information sticker (Fig. 4) with the information indicated. This sticker is inside the warranty group, it must also be filled out and applied on the outside of the appliance (in visible position) (see paragraph 3.2 Initial check).

1.3 MAIN DIMENSIONS

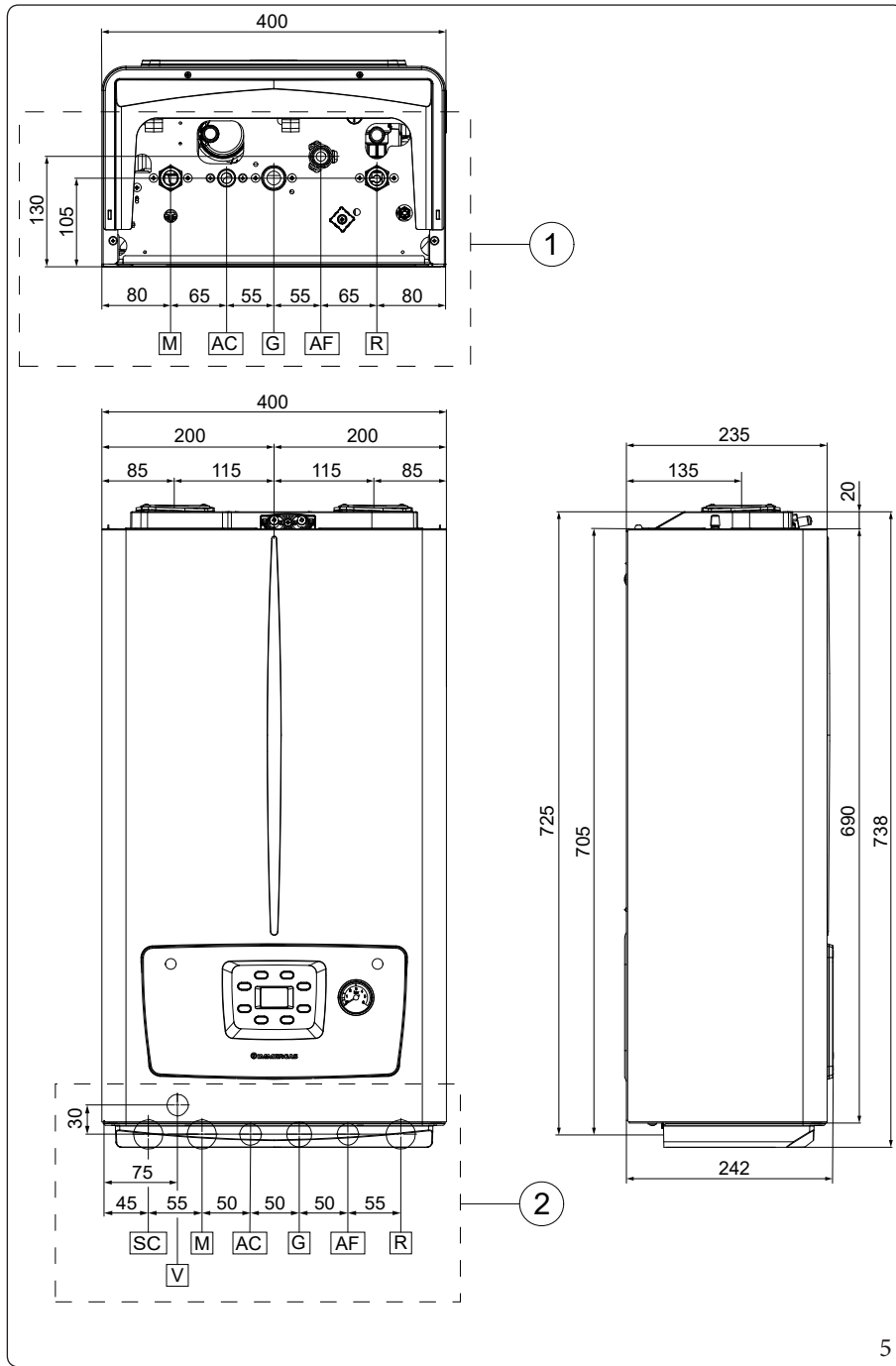

Key (Fig. 5):

- V - Electrical connection
- M - System flow
- SC - Condensate drain (minimum internal diameter Ø 13 mm)
- AC - Domestic hot water outlet
- G - Gas supply
- AF - Domestic hot water inlet
- R - System return

- 1 - Boiler direct hydraulic connection
- 2 - Wall-mounted hydraulic connection with Immergas DIN template

INSTALLER

USER

MAINTENANCE TECHNICIAN

TECHNICAL DATA

Height (mm)	Width (mm)		Depth (mm)	
738	400		242 (with Cover) 235 (without Cover)	
CONNECTIONS				
GAS	SYSTEM		DOMESTIC HOT WATER	
G	M	R	AF	AC
3/4"	3/4"		1/2"	



1.4 MINIMUM INSTALLATION DISTANCES

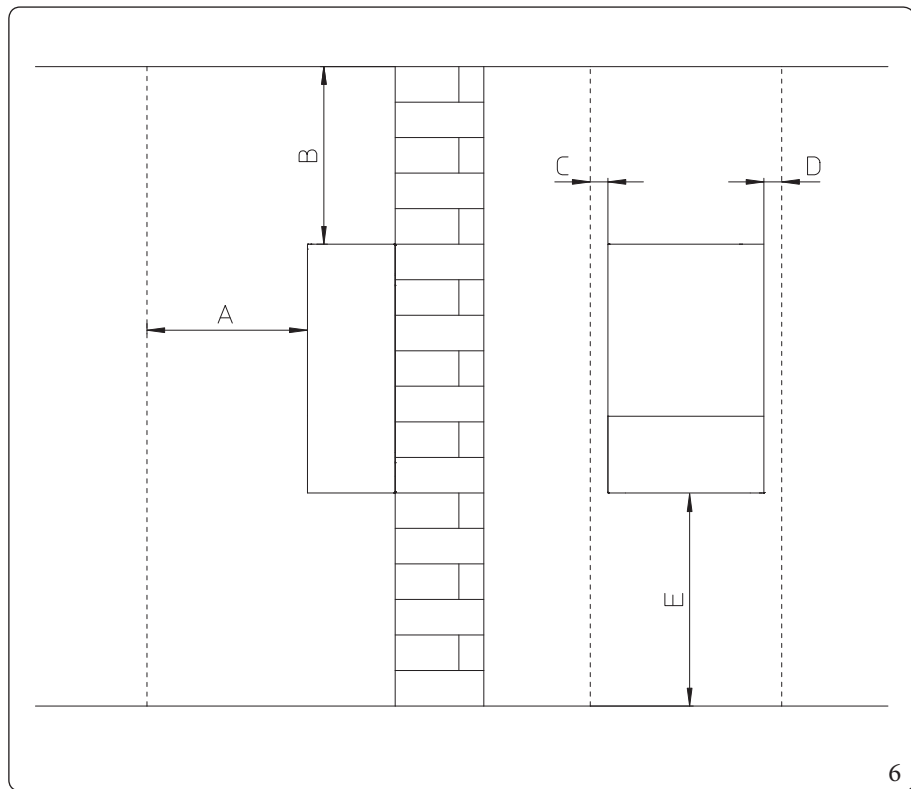

Key (Fig. 6):

- A - 450 mm
- B - 350 mm
- C - 30 mm
- D - 30 mm
- E - 350 mm

6

1.5 ANTIFREEZE PROTECTION

Appliance antifreeze protection is thus only ensured if:

- the appliance is correctly connected to gas and electricity power supply circuits;
- the appliance is powered constantly;
- the appliance is not in "off" mode.
- the appliance is not in anomaly conditions (Parag. 2.5);
- the appliance essential components are not faulty.

To prevent the risk of freezing follow the instructions below:

- Protect the central heating circuit from freezing by inserting a good-quality antifreeze liquid into this circuit, which is specially suited for central heating systems and which is manufacturer guaranteed not to cause damage to the heat exchanger or other components of the appliance. The antifreeze liquid must not be harmful to one's health. The instructions of the manufacturer of this liquid must be strictly followed regarding the necessary percentage with respect to the minimum temperature at which the system must be kept.
- The materials used for the central heating circuit of Immergas appliances resist propylene glycol based antifreeze liquids (if the mixtures are prepared perfectly).



The excessive use of glycol could jeopardise the proper functioning of the appliance.



Follow the supplier's instructions for the life cycle duration and possible disposal of the antifreeze liquid.

- An aqueous solution must be made with potential pollution class of water 2 (EN 1717:2002 or local standards in force).

Minimum room temperature -5°C

The appliance comes as per standard with an antifreeze function that activates the pump and the burner when the system water temperature in the appliance falls below 4°C.



In these conditions, previously listed, the appliance is protected against freezing up to an ambient temperature of -5°C.



If the appliance is installed in a place where the temperature drops below -5°C, the appliance may freeze.

Minimum room temperature -15°C



When installing the appliance in locations where the temperature falls below -5°C, installation of the antifreeze kit is required, respecting all the conditions listed above. !da duplicazione!

Protect the domestic hot water circuit against freezing by using an accessory that is supplied on request (antifreeze kit) comprising two electric heating elements, the relevant wiring and a control thermostat (carefully read the installation instructions contained in the accessory kit pack).



In the previously listed conditions and with the addition of the antifreeze kit, the appliance is protected against freezing up to a temperature of -15°C.



The antifreeze systems described in this chapter are only to protect the appliance; the presence of these functions and devices does not exclude the possibility of parts of the system or domestic hot water circuit outside the appliance from freezing.



The warranty does not cover damage due to interruption of the electrical power supply and failure to comply with that stated on the previous pages.



1.6 INSTALLATION INSIDE THE RECESSED FRAME (OPTIONAL)

The boiler is designed for installation inside the Immergas recessed frame (supplied as optional).

The necessary parts for this type of installation (bracket) must also be purchased separately as optional kit.

To install proceed as follows:

- Install the bracket (2) inside the recessed frame fixing it with the screws (3) in the pre-drilled holes (Fig. 7).
- Wall-mount the boiler (4) by inserting the hooks of the bracket (2) in the relative seats (Fig. 8).
- The boiler (4) is now mounted inside the recessed frame (1) (Fig.9).

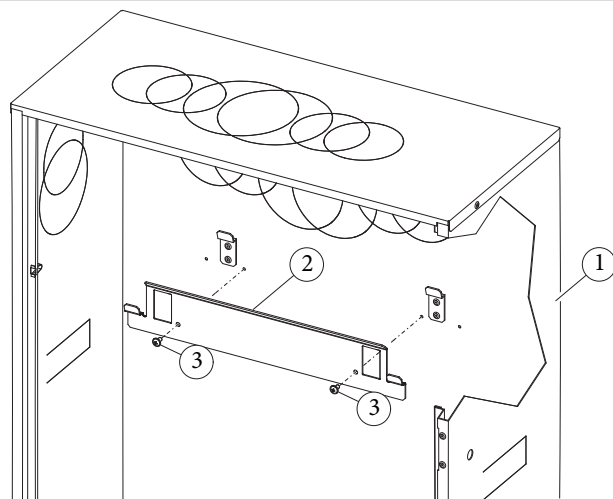

7

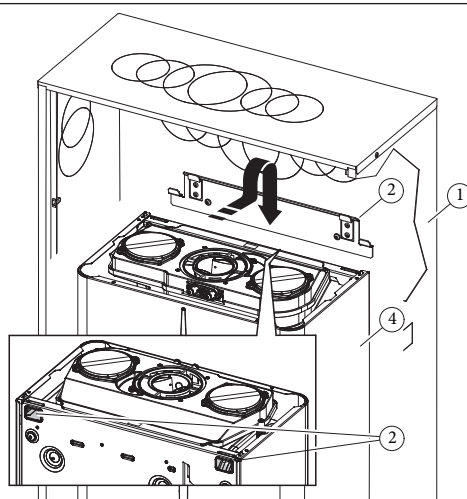

8

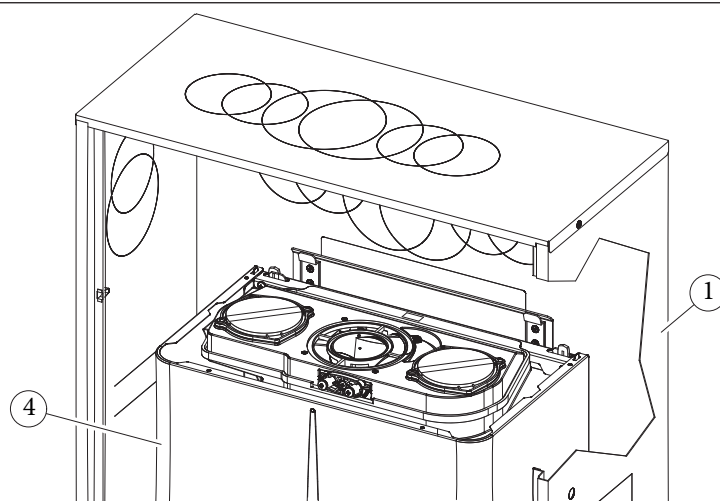

9

1.7 APPLIANCE CONNECTION UNIT (OPTIONAL)

The connection unit consisting of all the necessary parts to perform the hydraulic and gas system connections of the appliance comes as optional kit, perform the connections in accordance with the type of installation to be made and respecting the arrangement shown in figure below.

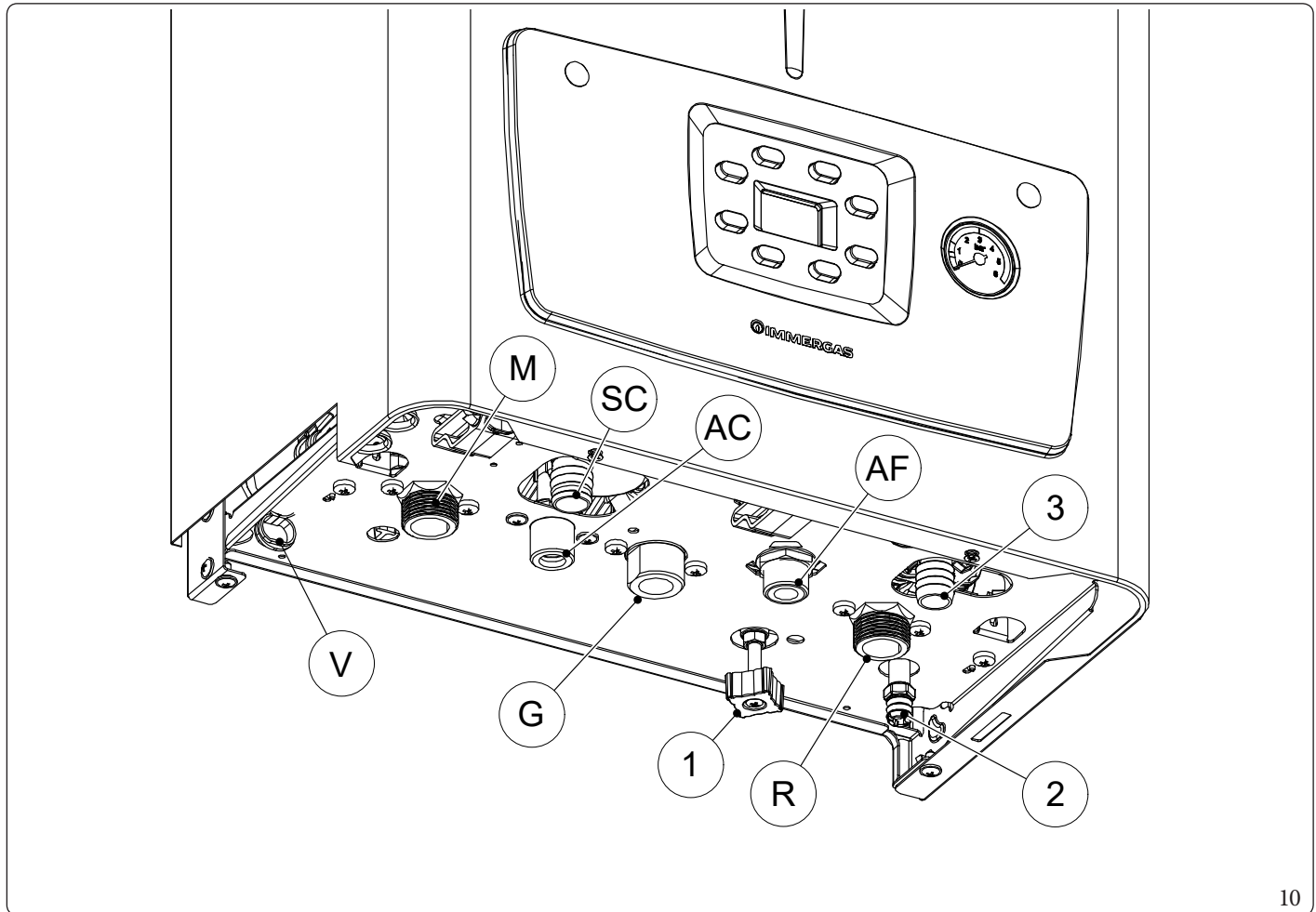

Key (Fig. 10):

- V - Electrical connection
- G - Gas supply
- AC - Domestic hot water outlet
- AF - Domestic hot water inlet
- SC - Condensate drain (minimum internal diameter Ø 13 mm)
- M - System flow
- R - System return

- 1 - System filling valve
- 2 - System draining valve
- 3 - 3-bar safety valve drain fitting



1.8 GAS CONNECTION



Before connecting the gas line, carefully clean inside all the fuel feed system pipes to remove any residue that could impair appliance efficiency.

Also make sure the gas corresponds to that for which the appliance is prepared (see appliance data nameplate).

If different, the boiler must be converted for operation with the other type of gas (see converting appliance for other gas types).



It is also important to check the dynamic pressure of the mains (methane or LPG) used to supply the boiler, which must comply with EN 437 and its attachment, as insufficient levels may reduce generator output and cause discomfort to the user. Static/dynamic network pressures higher than those required for regular operation may cause serious damage to the appliance control elements; in this case shut the gas line off.

Do not operate the device.

Have the device checked by experienced personnel.



According to the local regulation in force, make sure that a gas isolation valve is installed upstream of each connection between the appliance and the gas system. This valve, if supplied by the appliance's manufacturer, can be directly connected to the appliance (i.e. downstream from the pipes connecting the system to the appliance), according to the manufacturer's instructions.

The Immergas connection unit, supplied as an optional kit, also includes the gas isolation valve, whose installation instructions are provided in the kit.

In any case, make sure the gas isolation valve is connected properly.

The gas supply pipe must be suitably dimensioned according to current regulations in order to guarantee correct gas flow rate to the burner even in conditions of maximum generator output and to guarantee appliance efficiency (technical specifications).

The coupling system must conform to standards in force (EN 1775).



The appliance is designed to operate with fuel gas free from impurities; otherwise it is advisable to fit special filters upstream of the appliance to restore the purity of the fuel.

Storage tanks (in case of supply from LPG depot).

- New LPG storage tanks may contain residual inert gases (nitrogen) that degrade the mixture delivered to the appliance causing functioning anomalies.
- Due to the composition of the LPG mixture, layering of the mixture components may occur during the period of storage in the tanks. This can cause a variation in the calorific value of the mixture delivered to the appliance, with subsequent change in its performance.

1.9 HYDRAULIC CONNECTION



In order not to void the condensation module warranty, before making the device connections, carefully clean the heating system (pipes, radiators, etc.) with special pickling or descaling products to remove any deposits that could compromise correct device operation.

3 bar safety valve

The drain of the safety valve must always be properly conveyed to a tundish; consequently, in case of valve operation, the leaked fluid will end up in the sewer system.

Otherwise, the appliance manufacturer declines any responsibility in case of flooding if the drain valve cuts in.

Condensate drain

To drain the condensate produced by the appliance, it is necessary to connect to the drainage system by means of acid condensate resistant pipes, with an internal Ø of at least 13 mm.

The system connecting the appliance to the drainage system must be carried out in such a way as to prevent occlusion and freezing of the liquid contained in it.

Before appliance ignition, ensure that the condensate can be correctly removed. After first ignition, check that the drain trap is filled with condensate (Parag. 1.34).

Also, comply with national and local regulations on discharging waste waters.

In the event condensate is not discharged into the wastewater drainage system, a condensate neutraliser must be installed to ensure compliance with the parameters established by the legislation in force.

The current technical standards in force prescribes the washing and treatment of the water in the heating and water system, in order to protect the system and the appliance from deposits (e.g. scale), slurry or other hazardous deposits.

In order not to void the heat exchanger warranty, you are required to comply with what has been prescribed in (Par. 1.32).

Hydraulic connections must be made in a rational way using the couplings on the appliance template.



The manufacturer declines all liability in the event of damage caused by the installation of an automatic filling system.

In order to meet the system requirements established by EN 1717 in terms of pollution of drinking water, we recommend installing the IMMERGAS anti-backflow kit to be used upstream of the cold water inlet connection of the appliance. We also recommend using category 2 heat transfer fluid (e.g.: water+ glycol) in the appliance's primary circuit (C.H. circuit), as defined in standard EN 1717.



To preserve the duration of appliance efficiency features, in the presence of water whose features can lead to the deposit of lime scale, installation of the "polyphosphate dispenser" kit is recommended.



1.10 ELECTRICAL CONNECTION



The electrical system must be built in compliance with technical standards and all legislation in force.

The appliance has an IPX5D protection degree; electrical safety of the appliance is achieved only when it is connected properly to an efficient earthing system, as specified by current safety standards.



The manufacturer declines any responsibility for damage or physical injury caused by failure to connect the appliance to an efficient earthing system or failure to comply with the local reference standards.



Open the control panel connections compartment

To carry out electrical connections, all you have to do is open the connections compartment as follows.

Remove the casing:

1. Loosen the screw (a) at the bottom.
2. Rotate the control panel and then loosen the screw (b) that secures the control panel's (d) cover.
3. Press the three hooks (c) on the cover (d).
4. Remove the cover (d) from the control panel (e).

At this point, it is possible to access the terminal board (f).

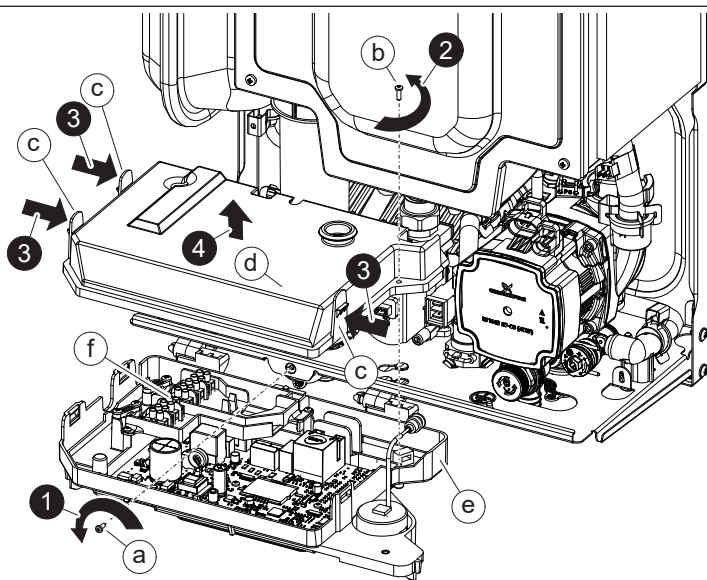

11

Also ensure that the electrical installation corresponds to maximum absorbed power specifications as shown on the boiler data nameplate.

The boilers are supplied complete with a "Y" type H05 VVF 3 x 0.75 mm² power supply cable, without plug.



The power supply cable must be connected to a 230V \pm 10% / 50Hz mains supply respecting L-N polarity and earth connection; this network must also have a multi-pole circuit breaker with class III overvoltage category in compliance with installation regulations.



All appliance pipes must never be used to earth the electric or telephone system.





To protect from possible leakage of DC voltage, it is necessary to provide a type A or type F residual current safety device with 30 mA sensitivity.



If the power cable is damaged, contact a qualified company (e.g. the Authorised Technical Assistance Centre) for its replacement to avoid a hazard.

The power supply cable must be laid as shown (Par. 1.7);

If the network fuse on the connection terminal board needs replacing, this must also be done by qualified personnel: use a 3.15 A fast fuse. For the main power supply to the appliance, never use adapters, multiple sockets or extension leads.

Installation with system operating at direct low temperature

The appliance can directly supply a low temperature system by setting the flow temperature adjustable range "t0" and "t1" (Par.3.13); in this situation it is good practice to insert a relevant safety kit (optional) made up of a thermostat (with adjustable temperature).

The thermostat must be positioned on the system flow pipe at a distance of at least 2 metres from the appliance.



1.11 REMOTE CONTROLS AND ROOM CHRONO-THERMOSTATS (OPTIONAL)

The appliance is set up for room chrono-thermostats or remote controls, available as optional kits.

All Immergas chrono-thermostats are connected with 2 wires only.

Carefully read the user and assembly instructions contained in the accessory kit.



Disconnect power to the unit before making any electrical connections.

On/Off Immergas digital chrono-thermostat.

The chrono-thermostat allows:

- set two room temperature value: one for day (comfort temperature) and one for night (reduced temperature);
- set a weekly programme with four daily switch on and switch off times;
- selecting the required function mode from the various possible alternatives:
 - manual mode (with adjustable temperature);
 - automatic mode (with set programme);
 - forced automatic operation (momentarily changing the temperature of the automatic program).

The chrono-thermostat is powered by two 1.5V LR6 type alkaline batteries.

“Comando Amico Remoto” (Remote Control Device) v2 (CARv2) with climate chrono-thermostat function.

In addition to the functions described in the previous point, the CARv2 panel enables the user to control all the important information regarding operation of the appliance and the heating system with the opportunity to easily intervene on the previously set parameters, without having to go to where the appliance is installed.

The panel is equipped with self-diagnosis to show any appliance operating anomalies on the display.

The climate chrono-thermostat incorporated into the remote panel enables the system flow temperature to be adjusted to the actual needs of the room being heated, in order to obtain the desired room temperature with extreme precision and therefore with evident saving in running costs.

The CARv2 is fed directly by the appliance by means of the same 2 wires used for the transmission of data between the appliance and device.

“Comando Amico Remoto” (Remote Control Device) v2 or On/Off chrono-thermostat electrical connection (Optional).



The operations described below must be performed after having removed the voltage from the appliance.

Any On/Off room thermostat or chrono-thermostat must be connected to terminals 44/40 and 41, eliminating link X40.

Make sure that the On/Off thermostat contact is of the “clean” type, i.e. independent of the mains voltage, otherwise the P.C.B. would be damaged.

Any Comando Amico Remoto remote control V2 must be connected to terminals 44/40 and 41, eliminating jumper X40 on the P.C.B. (Fig. 63).

The boiler can only be connected to one remote control.



If the Comando Amico Remoto remote control v2 or any other On/Off chrono-thermostat is used arrange two separate lines in compliance with current regulations regarding electrical systems.

All appliance pipes must never be used to earth the electric or telephone system.

Ensure elimination of this risk before making the appliance electrical connections.



1.12 EXTERNAL TEMPERATURE PROBE (OPTIONAL)

The appliance is prepared for the application of the external probe (Fig. 12), which is available as an optional kit.

Refer to the relative instruction sheet for positioning of the external probe.

The probe can be connected directly to the appliance electrical system and allows the max. system flow temperature to be automatically decreased when the external temperature increases, in order to adjust the heat supplied to the system according to the change in external temperature.

The external probe always operates when connected, regardless of the presence or type of room chrono-thermostat used and can work in combination with Immergas chrono-thermostats.

Use the curve shown in the diagram in Fig. 13 when CAR^{v2} is not connected to the boiler; use the curve shown in the CAR^{v2} instruction booklet when CAR^{v2} is connected to the boiler.

The electric connection of the external probe must be made on terminals 38 and 39 on the terminal board on the appliance control panel (Fig. 63).

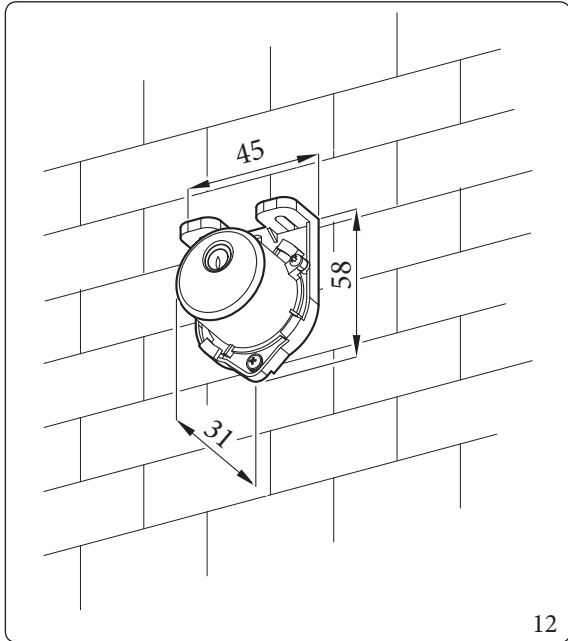

Correction law of the flow temperature depending on the external temperature and user adjustment of the central heating temperature.

* Position of the central heating temperature control.

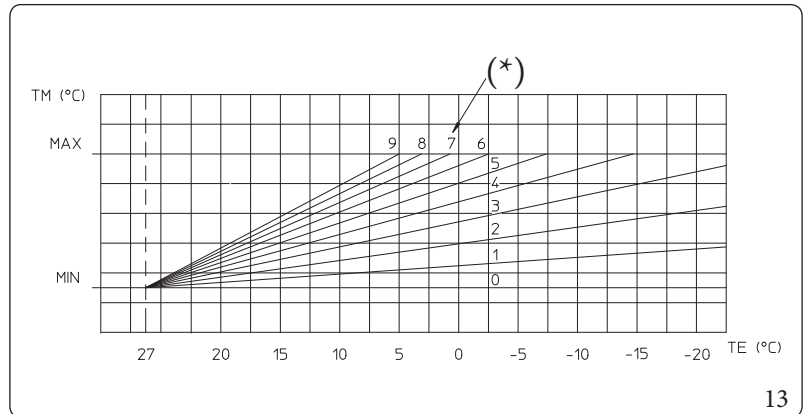

1.13 GENERAL EXAMPLES OF TYPES OF INSTALLATION OF FLUE SYSTEMS



For the types of installation of flue systems approved for this product, strictly follow the table in Parag. 4.3, in the line “Type of flue installation”.

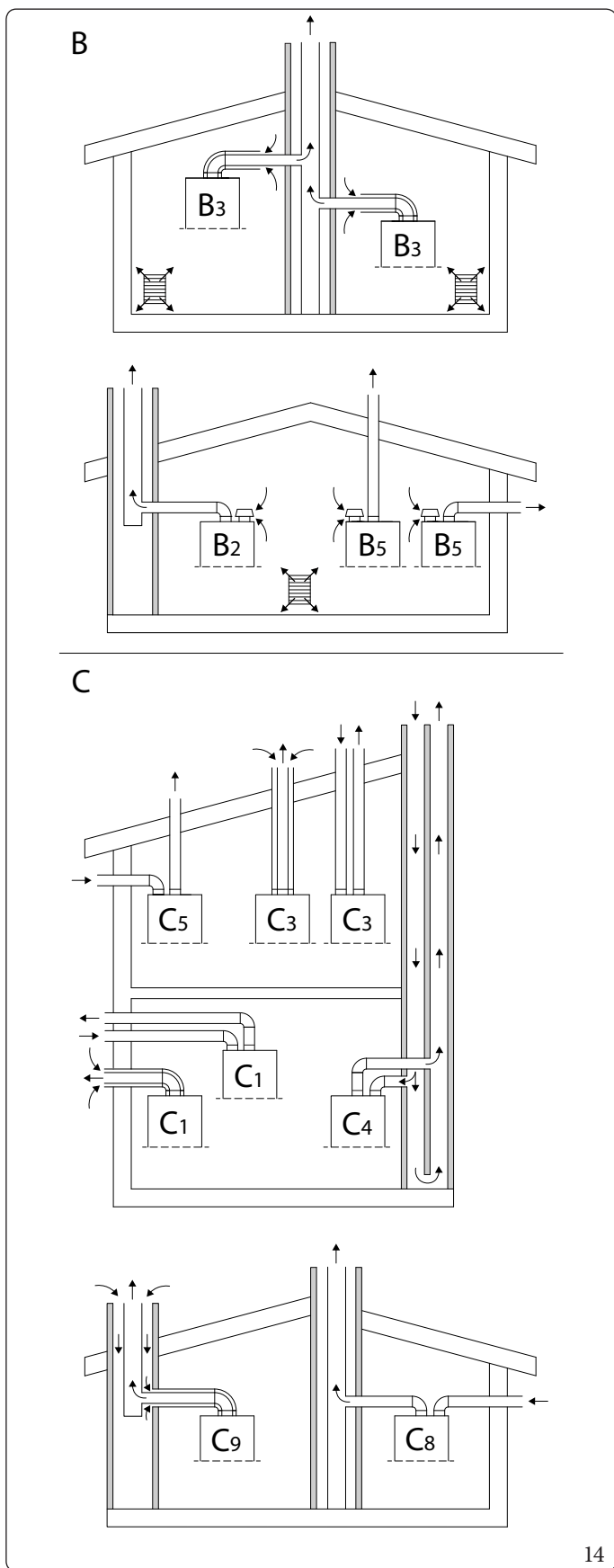

Installation types summarised table (Fig. 14):	
B	Appliance that withdraws air from the environment where it is installed and releases combustion products outside (either directly or through the flue).
B ₂	Appliance that withdraws air from the environment where it is installed and releases combustion products in the flue.
B ₃	Appliance connected to a conventional flue. A concentric pipe connects the flue to the appliance, in which the pressurised exhaust pipe is completely enveloped by combustion air withdrawn from inside the room. The combustion air is withdrawn by calibrated orifices present in the intake pipe.
B ₅	Appliance that withdraws air from the environment where it is installed and directly releases combustion products outside (through wall or roof).
C	Appliance whose combustion circuit (air feed, combustion chamber, heat exchanger and exhaust of combustion products) is sealed with respect to the room where the appliance is installed.
C ₁	Appliance with pipes connecting to a horizontal terminal, which simultaneously allows the inlet of combustion air and the release of flue gas through concentric orifices or close enough to be in similar wind conditions.
C ₃	Appliance with pipes connecting to a vertical terminal, which simultaneously allows the inlet of combustion air and the release of flue gas through concentric orifices or close enough to be in similar wind conditions.
C ₄	Appliance with two separate pipes connecting to a collective conventional flue. The flue consists of two pipes, concentric or separate, with air intake in one and flue gas release in the other and are in similar wind conditions.
C ₅	Appliance that withdraws air from outside and directly releases combustion products outside (through wall or roof). These pipes can end up in different pressure zones.
C ₆	Type C appliance intended to be connected to an approved system and sold separately.
C ₈	Appliance connected, through the exhaust pipe, to an individual or collective conventional flue. A second pipe is provided for the intake of combustion air from outside.
C ₉	Appliance connected, through a ducted exhaust pipe, to a vertical terminal. The exhaust pipe, by means of the cavity, also acts as a combustion air intake pipe.

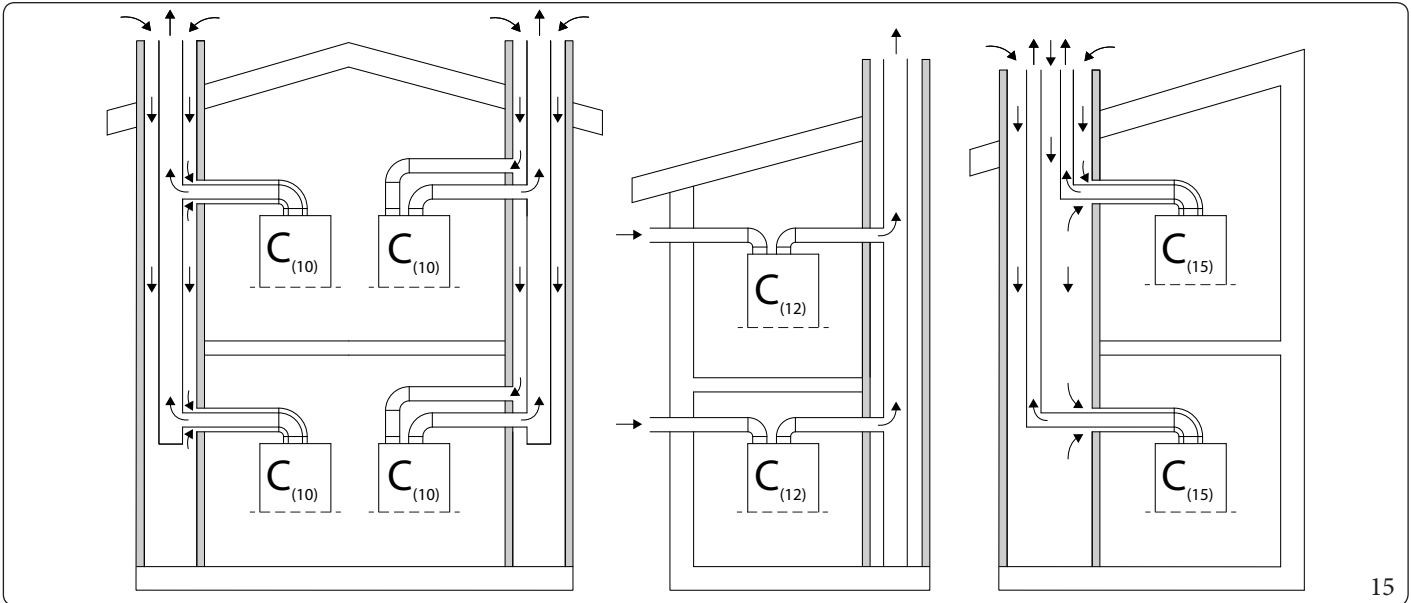

15

Installation types summarised table (Fig. 15):

C ₍₁₀₎	Appliance intended for connection, via its ducts, to a collective flue designed for more than one appliance. This flue consists of two ducts connected to a terminal, which simultaneously allows combustion air to enter and flue gas to be exhausted through orifices that are concentric or close enough to be in similar wind conditions.
C ₍₁₂₎	Appliance intended for connection, via its exhaust duct, to a collective flue designed for more than one appliance. A second duct, an integral part of the appliance, is provided for the intake of combustion air from outside.
C ₍₁₅₎	Appliance connected to a vertical flue exhaust terminal and a common vertical duct, designed for more than one appliance, for air intake. This duct simultaneously allows the inlet of combustion air and the release of flue gas through concentric orifices or close enough to be in similar wind conditions.

i The technical combustion parameters (except configurations C₆) are displayed in Paragraph Chapter 4.2 "Combustion parameters"

i The technical data required for configuration C₆ (commercial flue) are indicated in Paragraph Chapter 1.28 "Configuration for C₆ flue installation".

1.14 IMMERGAS FLUE SYSTEMS

Immergas supplies various solutions separately from the appliances regarding the installation of air intake and flue exhaust terminals, which are fundamental for appliance operation.

These solutions form an integral part of the product.

! The appliance must be installed with an original Immergas "Green Range" inspectionable air intake system and flue gas extraction system made of plastic, with the exception of configuration C₆ in the configurations envisaged in Parag. 1.13, as required by the regulations in force and by the product's approval. This flue can be identified by an identification mark and special distinctive marking bearing the note "only for condensation boilers".
For non-original flue system, refer to the technical data of the appliance.

! The plastic pipes cannot be installed outdoors, for tracts longer than 40 cm, without suitable protection from UV rays and other atmospheric agents.



Positioning the gaskets for “green range” flue systems.

Position the gasket correctly (for bends and extensions) (Fig. 16):

- gasket (A) with notches, to use for bends;
- gasket (B) without notches, to use for extensions.

If necessary, to ease the push-fitting, spread the supplied lubricants on the parts.

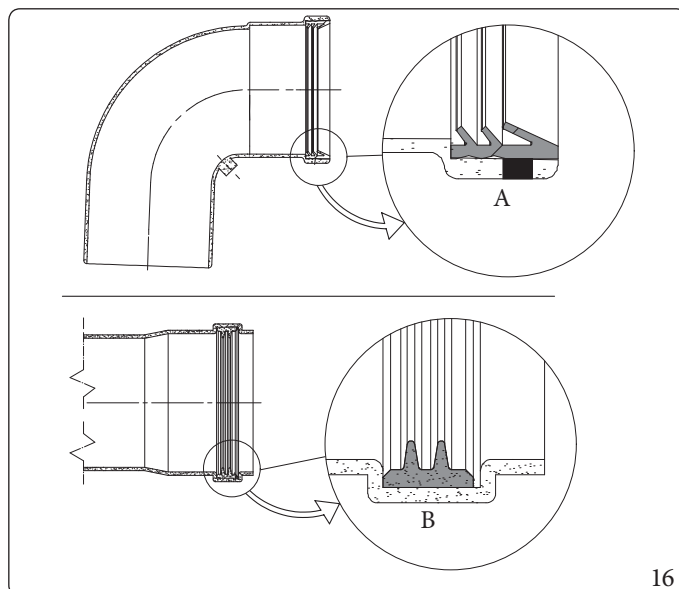

16

Extension pipes and concentric elbows push-fittings.

To install push-fitting extensions with other elements of the flue, proceed as follows:

- Install the concentric pipe or elbow with the male side (smooth) on the female side (with lip seal) to the end stop on the previously installed element in order to ensure sealing efficiency of the coupling.



If the exhaust terminal and/or extension concentric pipe needs shortening, consider that the internal duct must always protrude by 5 mm with respect to the external duct.



For safety purposes, do not even temporarily obstruct the appliance intake/exhaust terminal.

The various parts of the flue system must be checked to ensure that they have been laid in such a way as to prevent the coupled parts from detaching, in particular, the flue exhaust duct in the Ø80 separator kit configuration. If the condition described above is not adequately guaranteed, it will be necessary to use the appropriate retaining clamp kit.



When installing horizontal pipes, a minimum inclination of 5% towards the appliance must be maintained, and a section clamp with plug must be installed every 3 metres.



1.15 MAXIMUM FLUE LENGTH



The maximum flue length (L_{max}) is understood to include the terminal.



To calculate the equivalent length of the flue (L), simply add, for each component you intend to use, the corresponding value indicated in the column "Length equivalent to m of pipe" in the table in par. 1.16, and check that the resulting sum is equal to or less than the maximum length (L_{max}) indicated in par. 1.15. ($L \leq L_{max}$).



Should L be higher than L_{max} , consider using another type of flue.

Type	Installation	VICTRIX OMNIA V2 L_{max} = Maximum length (m)
Ø 60/100mm	C_{13} (horizontal+elbow+terminal)	13
	C_{33} (vertical+terminal)	14.5
Ø 80/125mm	C_{13} (horizontal+elbow+terminal) C_{33} (vertical+terminal)	35
	$C_{(10)3} - C_{(15)3}$	9
Ø 80/80mm	$C_{43} - C_{53} - C_{83}$ (split)	35
	$C_{(10)3} - C_{(12)3}$	10
	$B_{23} - B_{23p} - B_{33} - B_{53} - B_{53p}$	30
Ø 50 flexible	C_{53} Split 80/80 with intake by own terminal and exhaust in exposed or ducted Immergas pipe.	13
Ø 60mm rigid		25
Ø 80mm rigid		35
Ø 80 flexible		30
Ø 50 flexible	$C_{93} C_{(15)3}$ Concentric 60/100 or 80/125 with exhaust in ducted pipe and intake from technical slot.	13
Ø 60mm rigid		25
Ø 80mm rigid		35
Ø 80 flexible		30

Note: Installation $C_{10} - C_{12}$ type-approved only with G20 gas.









The values indicated in the table are the maximum available lengths.
Adjustment of the maximum boiler speed depending on the length of the actual pipes installed must refer to the Table in Par. 3.12.
The flue parameter (heat output) must be calibrated by the maintenance technician at initial testing.



The unit of measurement is in "mm" if not specified otherwise.























1.16 EQUIVALENT LENGTHS OF "GREEN RANGE" FLUE SYSTEM COMPONENTS.

Equivalent concentric lengths Ø 60/100			
Ø duct [mm]	Type of duct	Picture	Equivalent length in [m] of concentric pipe Ø 60/100 mm
60/100	Pipe Ø 60/100 mm L = 1 m		1,0
	90° bend Ø 60/100 mm		1,3
	45° bend Ø 60/100 mm		1,0
	Horizontal terminal Ø 60/100 mm L = 1 m		
	Horizontal terminal Ø 60/100 mm L = 1 m adjustable		0° spout 45° spout
	Vertical terminal Ø 60/100 mm L = 1,25 m		



The values of the equivalent lengths in metres of concentric pipe of the Ø60/100 terminals are not the actual ones, but are weighted values to be used for the calculation of the flue.

Equivalent concentric lengths Ø 80/125			
Ø duct [mm]	Type of duct	Picture	Equivalent length in [m] of concentric pipe Ø 80/125 mm
80/125	Pipe Ø 80/125 mm L = 1 m		1,0
	90° bend Ø 80/125 mm		1,4
	45° bend Ø 80/125 mm		1,0
	Reduction kit from Ø 60/100 to Ø 80/125 mm		0,5
	Horizontal terminal Ø 80/125 mm L = 0,75 m		
	Horizontal terminal Ø 80/125 mm L = 1 m		
	Vertical terminal Ø 80/125 mm L = 1 m		

Equivalent lengths split Ø 80/80 and rigid ducting Ø 80				
Ø duct [mm]	Type of duct	Picture	Equivalent length in [m] of pipe Ø 80 mm	
			Exhaust	Intake
80/80 and rigid 80	Pipe Ø 80 mm L = 1 m		Exhaust	1,0
	90° bend Ø 80 mm		Exhaust	2,1
			Intake	1,6
	45° bend Ø 80 mm		Exhaust	1,3
			Intake	1,0
	Horizontal terminal Ø 80 mm L = 1 m		Exhaust	3,5
			Intake	2,5
	Horizontal terminal Ø 80 mm grid part		Exhaust	2,5
			Intake	1,8
	Vertical terminal Ø 80 mm L = 1 m		Exhaust	3,0
	Stainless steel vertical terminal Ø 80 mm L = 1 m		Exhaust	3,0
	Suction kit Ø 80 mm for configuration B		Intake	4,3
	Vertical terminal Ø 80 mm L = 1,25 m		Exhaust	4,6
	Pipe Ø 80/125 mm L = 1 m			1,8
	90° bend Ø 80/125 mm			2,5
45° bend Ø 80/125 mm			1,8	
Reduction kit from Ø 60/100 to Ø 80/125 mm			0,9	
Thermoformed kit for type B installation		Intake	4,0	



















INSTALLER















USER

MAINTENANCE TECHNICIAN

TECHNICAL DATA



Equivalent lengths Ø 50 flexible ducting				
Ø duct [mm]	Type of duct	Picture	Equivalent length in [m] of flexible hose Ø 50 mm	
			Exhaust	Intake
50 Hose	Corrugated hose Ø 50 mm L = 1 m		Exhaust	1,0
	Kit T Ø 80 mm + reduction to Ø 50 mm		Exhaust	0,6
	Exhaust T-terminal kit Ø 80 mm + reduction to Ø 50 mm		Exhaust	1,0
	Ø 80 mm bend kit + reduction to Ø 50 mm		Exhaust	1,2
	Vertical terminal Ø 80 mm + reduction to Ø 50 mm		Exhaust	0,5
	Female/female kit Ø 50 mm		Exhaust	0,4
	Pipe Ø 80 mm L = 1 m		Exhaust	0,1
			Intake	0,1
	90° bend Ø 80 mm		Exhaust	0,3
			Intake	0,2
	45° bend Ø 80 mm		Exhaust	0,2
			Intake	0,1
	Horizontal terminal Ø 80 mm L = 1 m		Exhaust	0,3
			Intake	0,3
	Horizontal terminal Ø 80 mm grid part		Exhaust	0,2
			Intake	0,2
	Pipe Ø 60/100 mm L = 1 m			0,6
	90° bend Ø 60/100 mm			0,8
	45° bend Ø 60/100 mm			0,6
	Pipe Ø 80/125 mm L = 1 m		Exhaust	0,2
			Intake	0,2
	90° bend Ø 80/125 mm			0,3
	45° bend Ø 80/125 mm			0,2
	Reduction kit from Ø 60/100 to Ø 80/125 mm			0,1
Suction kit Ø 80 mm for configura- tion B		Intake	0,5	

Equivalent ducting lengths Ø 60 rigid				
Ø duct [mm]	Type of duct	Picture	Equivalent length in [m] of rigid pipe Ø 60 mm	
60 rigid	Pipe Ø 60 mm L = 1 m		Exhaust	1,0
	90° bend Ø 60 mm		Exhaust	1,1
	45° bend Ø 60 mm		Exhaust	0,6
	Vertical terminal Ø 60 mm L = 1 m		Exhaust	3,7
	Reduction Ø 80 to Ø 60 mm		Exhaust	0,8
	Pipe Ø 80 mm L = 1 m		Exhaust	0,4
			Intake	0,3
	90° bend Ø 80 mm		Exhaust	0,8
			Intake	0,6
	45° bend Ø 80 mm		Exhaust	0,5
			Intake	0,4
	Horizontal terminal Ø 80 mm L = 1 m		Intake	0,9
	Horizontal terminal Ø 80 mm grid part		Intake	0,7
	Pipe Ø 60/100 mm L = 1 m		Exhaust	2,0
	90° bend Ø 60/100 mm		Exhaust	2,5
45° bend Ø 60/100 mm		Exhaust	2,0	
Suction kit Ø 80 mm for configuration B		Intake	1,6	



















INSTALLER









USER







MAINTENANCE TECHNICIAN

TECHNICAL DATA



Equivalent lengths Ø 80 flexible ducting				
Ø duct [mm]	Type of duct	Picture	Equivalent length in [m] of flexible hose Ø 80 mm	
			Exhaust	Intake
80 Hose	Corrugated hose Ø 80 mm L = 1 m		Exhaust	1,0
	70° bend Ø 80 mm		Exhaust	1,0
	T-kit Ø 80 mm		Exhaust	1,1
	T-shaped exhaust terminal Ø 80 mm		Exhaust	1,6
	Vertical terminal Ø 80 mm		Exhaust	0,7
	Adapter Ø 80 mm flexible/male		Exhaust	0,2
	Adapter Ø 80 mm flexible/flexible		Exhaust	0,2
	Adapter Ø 80 mm flexible/flexible		Exhaust	0,3
	Vertical terminal Ø 80mm L = 1,25 m		Exhaust	1,7
	Pipe Ø 80 mm L = 1 m		Exhaust	0,4
			Intake	0,3
	90° bend Ø 80 mm		Exhaust	0,8
			Intake	0,6
	45° bend Ø 80 mm		Exhaust	0,5
			Intake	0,4
	Horizontal terminal Ø 80 mm L = 1 m		Intake	0,9
			Horizontal terminal Ø 80 mm grid part	
	Pipe Ø 80/125 mm L = 1 m			0,7
	90° bend Ø 80/125 mm			0,9
	45° bend Ø 80/125 mm			0,7
Reduction kit from Ø 60/100 to Ø 80/125 mm			0,3	
Suction kit Ø80 mm for configuration B		Intake	1,6	

Equivalent lengths $C_{(10)3} - C_{(12)3}$ concentric $\varnothing 80/125$ mm				
\varnothing duct [mm]	Type of duct	Picture	Equivalent length in [m] of pipe $C_{(10)3} - C_{(12)3}$ concentric $\varnothing 80/125$ mm	
			Exhaust	
$C_{(10)3} - C_{(12)3}$ 80/125	Clapet $\varnothing 80$ mm		Exhaust	
	Pipe $\varnothing 80/125$ mm L = 1 m			1,0
	90° bend $\varnothing 80/125$ mm			1,4
	45° bend $\varnothing 80/125$ mm			1,0
	Reduction kit from $\varnothing 60/100$ to $\varnothing 80/125$ mm			0,5
	Pipe $\varnothing 80$ mm L = 1 m		Exhaust	0,6
	90° bend $\varnothing 80$ mm		Exhaust	1,2
	45° bend $\varnothing 80$ mm		Exhaust	0,7

Equivalent lengths $C_{(10)3} - C_{(12)3}$ split $\varnothing 80/80$ mm				
\varnothing duct [mm]	Type of duct	Picture	Equivalent length in [m] of pipe $C_{(10)3} - C_{(12)3}$ split $\varnothing 80/80$ mm	
			Exhaust	Intake
$C_{(10)3} - C_{(12)3}$ 80/80	Clapet $\varnothing 80$ mm		Exhaust	
	Pipe $\varnothing 80$ mm L = 1 m		Exhaust	1,0
			Intake	0,7
	90° bend $\varnothing 80$ mm		Exhaust	2,1
			Intake	1,6
	45° bend $\varnothing 80$ mm		Exhaust	1,3
			Intake	1,0
	Horizontal terminal $\varnothing 80$ mm L = 1 m		Intake	2,5
	Horizontal terminal $\varnothing 80$ mm grid part		Intake	1,8



1.17 OUTDOOR INSTALLATION OR IN A PARTIALLY PROTECTED AREA



By partially protected area, we mean one in which the unit is not directly exposed to the elements (rain, snow, hail, etc.).



If the appliance is installed in a location where the ambient temperature falls below -5°C , use the optional antifreeze kit, checking the ambient temperature range for operation in the technical data table in this instruction manual (Section 'Technical Data').



This type of installation is possible when permitted by the laws in force in the appliance's country of destination.

Configuration type B, open chamber and fan assisted (B_{23} or B_{53}).

Using the relevant cover kit, direct air intake is possible and flue gas is exhausted into a single flue or directly to the outside. In this configuration it is possible to install the appliance in a partially protected place. In this configuration the appliance is classified as type B.

With this configuration:

- air intake takes place directly from the environment in which the appliance is installed (external);
- the flue gas exhaust must be connected to its own single chimney (B_{23}) or ducted directly outside via a vertical terminal for direct exhaust (B_{53}) or via an Immergas ducting system (B_{53}).

The technical regulations in force must be respected.

Cover kit assembly (Fig.17).

Remove the two plugs and the gaskets present from the two lateral holes with respect to the central one. Now cover the left intake hole using the relevant plate, fixing it onto the right side using the 2 previously-removed screws.

Install the $\varnothing 80$ outlet flange on the central hole of the boiler, taking care to insert the gasket supplied with the kit and tighten by means of the screws provided.

Install the upper cover, fixing it using the 4 screws present in the kit, positioning the relevant gaskets.

Engage the 90° $\varnothing 80$ bend with the male end (smooth) in the female end (with lip seal) of the $\varnothing 80$ flange unit to the end stop. Introduce the gasket, making it run along the bend. Fix it using the metal sheet plate and tighten by means of the clips present in the kit, making sure to block the 4 gasket flaps.

Fit the male end (smooth) of the exhaust pipe into the female end of the 90° $\varnothing 80$ bend, making sure that the relevant wall sealing plate is already fitted; this will ensure hold and joining of the elements making up the kit.

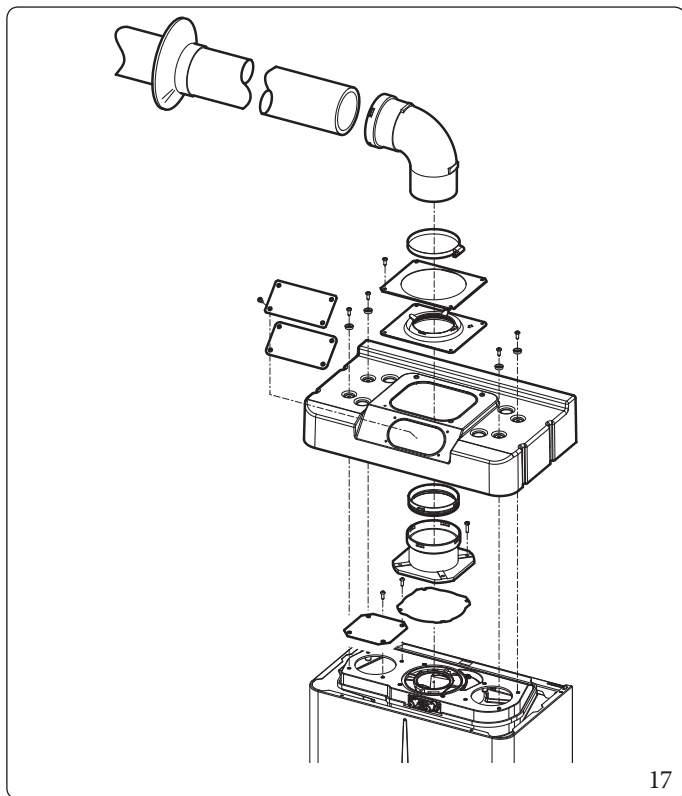

The cover kit includes (Fig. 17):

- No.1 Thermoformed cover
- No.1 Gasket clamping plate
- No.1 Gasket
- No.1 Gasket tightening clip
- No.1 Intake hole covering plate

The terminal kit includes (Fig. 17):

- No.1 Gasket
- No.1 Exhaust flange $\varnothing 80$
- No.1 90° bend $\varnothing 80$
- No.1 Exhaust pipe $\varnothing 80$
- No.1 Wall sealing plate



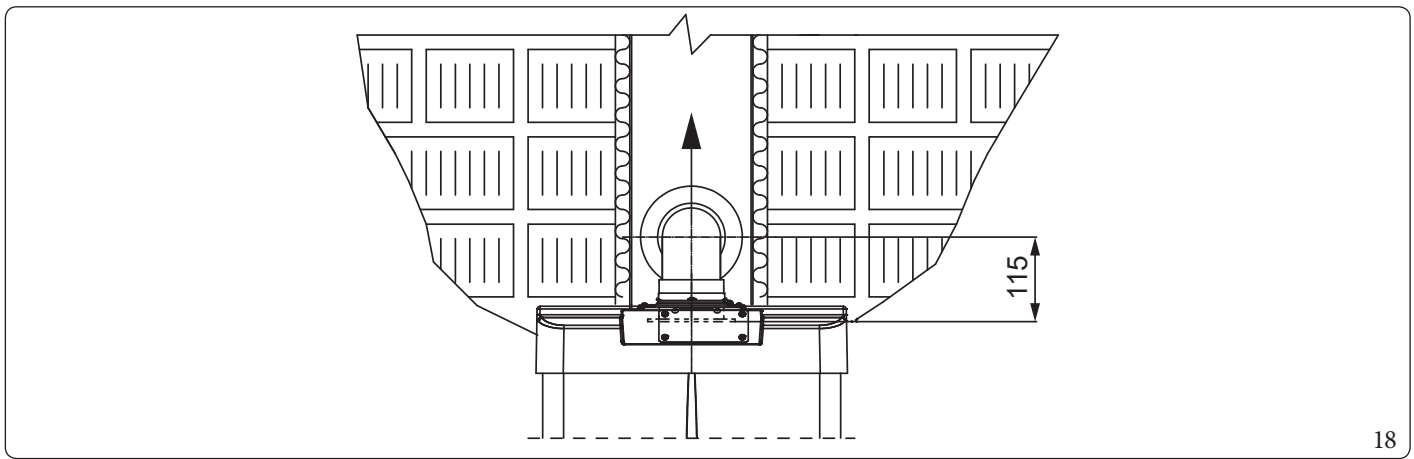

18

Coupling of extension pipes.

To install push-fitting extensions with other elements of the flue, proceed as follows: Couple the pipe or elbow with the male side (smooth) in the female side (with lip seal) to the end stop on the previously installed element. This will ensure sealing efficiency of the coupling.

Configuration without cover kit in a partially protected location (type C appliance).

By leaving the side plugs fitted it is possible to install the appliance externally without the cover kit.

Installation takes place using the $\varnothing 60/100$ and $\varnothing 80/125$ concentric intake/ exhaust kits. Refer to the paragraph on indoor installation. In this configuration the top cover kit that guarantees additional protection for the appliance is recommended but not compulsory.



The top cover kit, which provides additional protection for the boiler, CANNOT be used with $\varnothing 80/80$ separator configuration.



1.18 INTERNAL INSTALLATION USING A RECESSED FRAME WITH DIRECT AIR INTAKE

Configuration type B, open chamber and fan assisted

In this configuration the appliance is classified as type B₂₃.

Using a kit separator, one can achieve direct air intake (Fig. 19) and flue exhaust in a single chimney or directly outside.

With this configuration:

- air intake takes place directly from the environment in which the appliance is installed and only functions in permanently ventilated rooms;
- the flue gas exhaust must be connected to its own individual chimney and channelled directly into the external atmosphere.

The technical regulations in force must be respected.

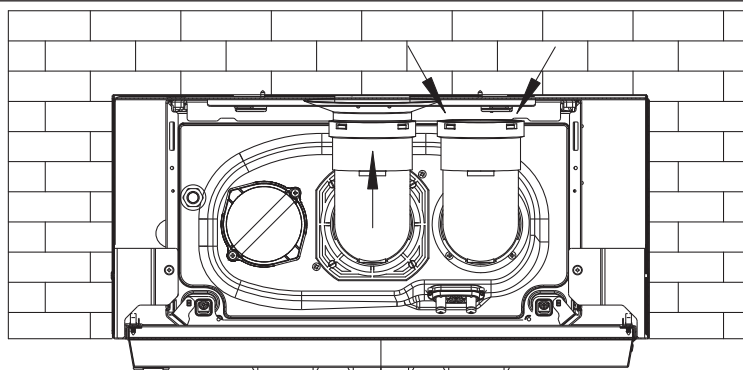

19

Separator kit installation (Fig. 20).

1. Install the discharge flange on the middle hole of the appliance, positioning the relative gasket with the circular projections downwards in contact with the appliance flange, and tighten using the hex screws with flat tip contained in the kit.
2. Remove the flat flange present in the lateral hole with respect to the central one (according to needs) and replace it with the intake flange, positioning its gasket and tighten using the supplied self-threading screws.
3. Fit the curves with the male side (smooth) into the female side of the flanges (the intake curve must face the rear side of appliance).
4. Fit the exhaust pipe with the male side (smooth) to the female side of the bend up to the end stop, making sure that the internal wall sealing plate has been fitted and connecting the required flue according to personal requirements.

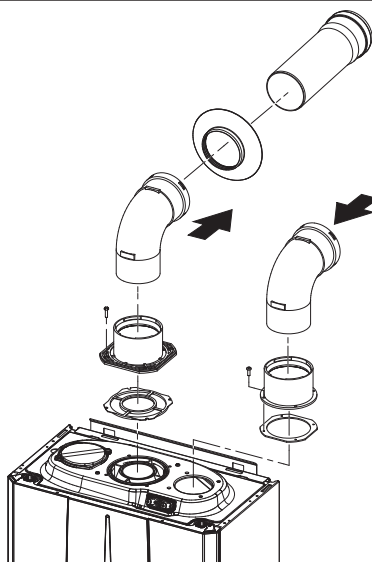

20

In case of installation C₍₁₀₎₃/C₍₁₂₎₃ the flue gas non-return valve must be installed and ONLY the vertical outlet can be installed in the recessed frame.

1.19 CONCENTRIC HORIZONTAL KIT INSTALLATION

Type C configuration, sealed chamber and fan assisted

The position of the terminal (in terms of distances from openings, overlooking buildings, floor, etc.) must be in compliance with the regulations in force.

This terminal is connected directly to the outside of the building for air intake and flue gas exhaust.

The horizontal kit can be installed with the rear, right side, left side or front outlet.

For installation with frontal outlet, one must use the fixing plate and a concentric bend coupling in order to ensure sufficient space to carry out the tests required by law upon commissioning.

External grid

Make sure that the external silicone wall sealing plate is properly inserted in the wall.



For correct functioning of the system the terminal with grid must be installed correctly ensuring that, the "high" indication present on the terminal is respected on installation.

Horizontal intake/exhaust assembly kits Ø 60/100 (Fig. 21)

1. Install the curve with flange (2) on the central hole of the appliance, positioning gasket (1) with the circular projections downwards in contact with the appliance flange, and tighten using the screws contained in the kit.
2. Fit the Ø 60/100 (3) concentric terminal pipe with the male side (smooth) to the female side of the bend (2) up to the end stop, making sure that the internal and external wall sealing plates have been fitted; this will ensure sealing and joining of the elements making up the kit.

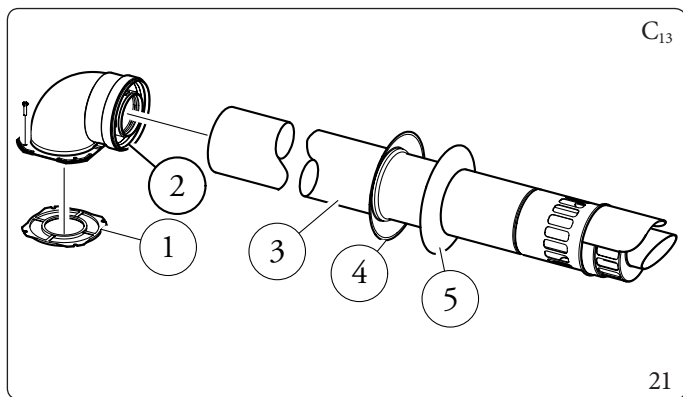

The kit includes (Fig. 21):

- N°1 Gasket (1)
- N°1 Concentric bend Ø 60/100 (2)
- N°1 Int./exhaust concentric terminal Ø 60/100 (3)
- N°1 Internal wall sealing plate (4)
- N°1 External wall sealing plate (5)

Extensions for horizontal kit Ø 60/100 (L = Equivalent length - L max = Maximum length) (Fig. 22).

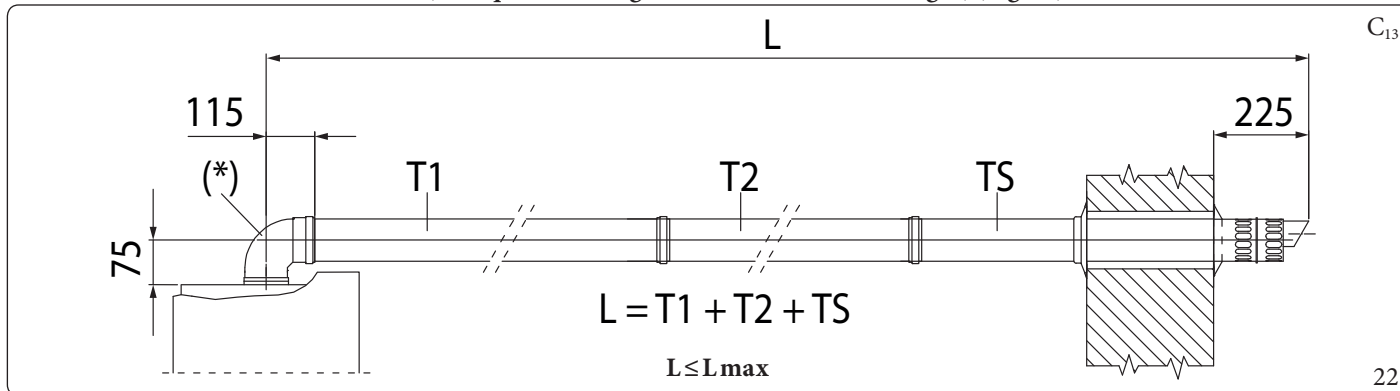

Key Fig. 22:

- T1 - Concentric pipe Ø 60/100
- (*) - 90° concentric elbow Ø 60/100 (do not consider when calculating the equivalent length)

- T2 - Concentric pipe Ø 60/100
- TS - Concentric intake / exhaust terminal Ø 60/100
- L - Equivalent length
- Lmax - Maximum length



The maximum lengths ((L max) of the various flues that can be installed are given in the summary table in parag. 1.15.



Installation examples

Example of calculation (VICTRIX OMNIA V2):

$L = 1 + 1 + 1 + 1 + 1 = 5 \text{ m}$

$5 \text{ m} \leq 13 \text{ m}$

$L \leq L_{\text{max}}$

Key Fig. 23:

- | | | | | | |
|-----|---|---|------|---|--|
| T1 | - | Concentric pipe Ø60/100 | C3 | - | Ø60/100 45° concentric elbow |
| (*) | - | 90° concentric elbow Ø60/100 (do not consider when calculating the equivalent length) | C4 | - | Ø60/100 90° concentric elbow |
| T2 | - | Concentric pipe Ø60/100 | TS | - | Concentric intake / exhaust terminal Ø60/100 |
| C2 | - | Ø60/100 45° concentric elbow | L | - | Equivalent length |
| | | | Lmax | - | Maximum length |



To calculate the equivalent length of the flue (L), simply add, for each component you intend to use, the corresponding value indicated in the column "Length equivalent to m of pipe" in the table in par. 1.16, and check that the resulting sum is equal to or less than the maximum length (L max) indicated in par. 1.15. ($L \leq L_{\text{max}}$).



Horizontal intake/exhaust assembly kits Ø 80/125 (Fig. 24)

To install the kit Ø 80/125 one must use the flanged adapter kit (pos. 2, Fig. 24).

1. Install the flanged adaptor (2) on the central hole of the appliance, positioning gasket (1) with the circular projections downwards in contact with the appliance flange, and tighten using the screws contained in the kit.
2. Engage the bend (3) with the male side (smooth) to the end stop on the adaptor (2).
3. Fit the Ø 80/125 (4) concentric terminal pipe with the male side (smooth) to the female side of the bend (3) (with lip seals) up to the end stop, making sure that the internal (5) and external wall sealing plates (6) have been fitted; this will ensure sealing and joining of the elements making up the kit.

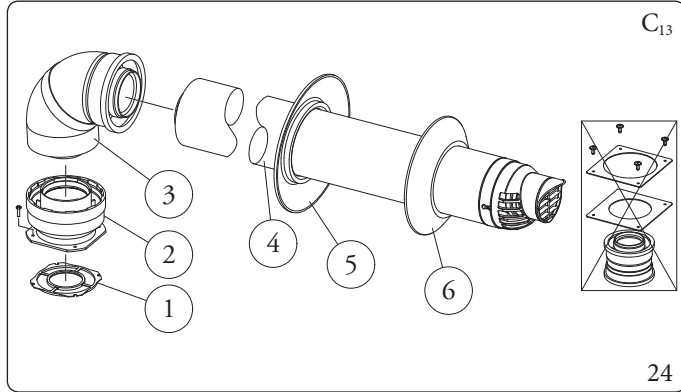

The adapter kit includes (Fig. 24):

- N°1 Gasket (1)
- N°1 Adapter Ø 80/125 (2)

The Ø 80/125 kit includes (Fig. 24):

- N°1 Concentric bend Ø 80/125 at 87° (3)
- N°1 Int./exhaust concentric terminal Ø 80/125 (4)
- N°1 Internal wall sealing plate (5)
- N°1 External wall sealing plate (6)

The remaining kit components must not be used

Extensions for horizontal kit Ø 80/125 (L = Equivalent length - Lmax = Maximum length) (Fig. 25).

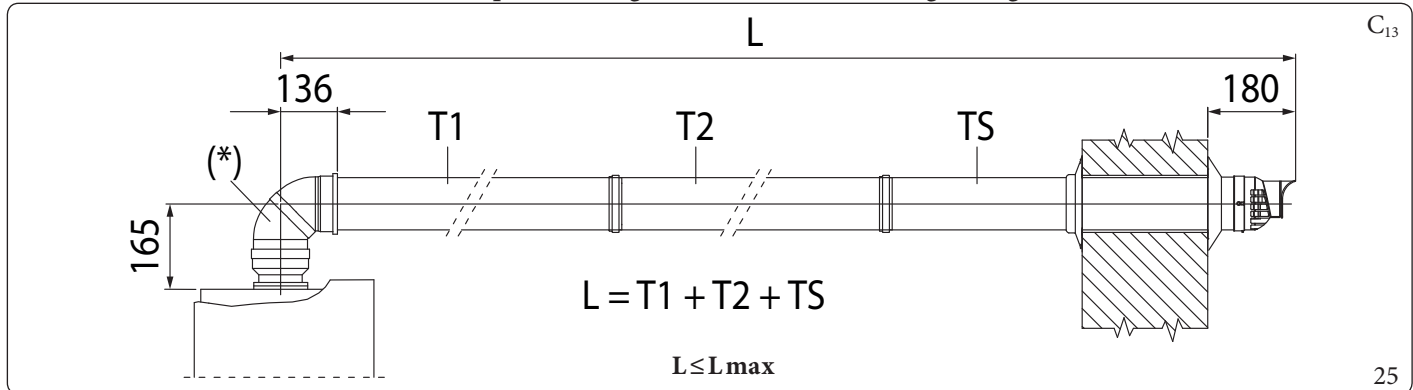

Key Fig. 25:

- T1 - Concentric pipe Ø 80/125
- (*) - 90° concentric elbow Ø 80/125 (do not consider when calculating the equivalent length)

- T2 - Concentric pipe Ø 80/125
- TS - Concentric intake / exhaust terminal Ø 80/125
- L - Equivalent length
- Lmax - Maximum length

i The maximum lengths ((Lmax) of the various flues that can be installed are given in the summary table in parag. 1.15.



Installation examples

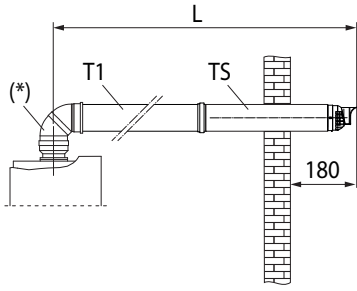

$$L = T1 + TS$$

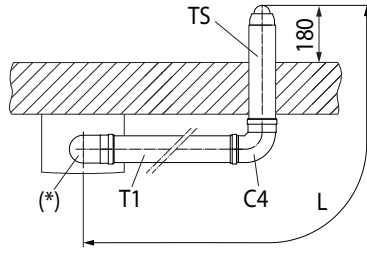

$$L = T1 + C4 + TS$$

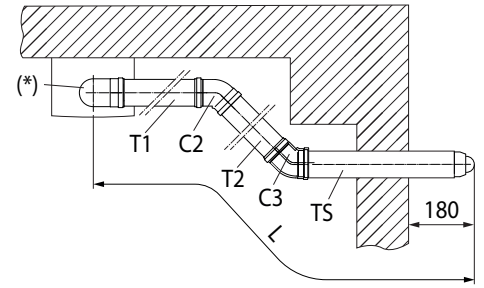

$$L = T1 + C2 + T2 + C3 + TS$$

Example of calculation (VICTRIX OMNIA V2):

$$L = 0,5 + 1,4 + 1 + 1,4 + 1 = 5,3 \text{ m}$$

$$5,3 \text{ m} \leq 35 \text{ m}$$

$$L \leq L_{\text{max}}$$

26

Key Fig. 26:

T1 - Concentric pipe Ø80/125

(*) - 90° concentric elbow Ø80/125 (do not consider when calculating the equivalent length)

T2 - Concentric pipe Ø80/125

C2 - Ø80/125 45° concentric elbow

C3 - Ø80/125 45° concentric elbow

C4 - Ø80/125 90° concentric elbow

TS - Concentric intake / exhaust terminal Ø80/125

L - Equivalent length

Lmax - Maximum length



To calculate the equivalent length of the flue (L), simply add, for each component you intend to use, the corresponding value indicated in the column "Length equivalent to m of pipe" in the table in par. 1.16, and check that the resulting sum is equal to or less than the maximum length (L max) indicated in par. 1.15. ($L \leq L_{\text{max}}$).



1.20 CONCENTRIC VERTICAL KIT INSTALLATION

Type C configuration, sealed chamber and fan assisted

Concentric vertical intake and exhaust kit.

This vertical terminal is connected directly to the outside of the building for air intake and flue gas exhaust.



The vertical kit with aluminium slate enables installation on terraces and roofs with a maximum slope of 45% (approx 25°) and the height between the terminal cap and half-shell (374 mm for Ø 60/100 and 260 mm for Ø 80/125) must always be observed.

1. Install the concentric flange (2) on the flue exhaust of the appliance, positioning gasket (1) with the circular projections downwards in contact with the appliance flange.
2. Tighten the concentric flange with the screws in the kit.

Vertical kit assembly with aluminium slate Ø60/100 (Fig. 27)

Imitation aluminium slate installation:

1. Replace the slates with the aluminium sheet (4), shaping it to ensure that rainwater runs off.
2. Position the fixed half-shell (6) on the aluminium slate.
3. Insert the intake-exhaust pipe (5).
4. Fit the Ø 60/100 concentric terminal pipe with the male side (5) (smooth) into the flange (2) up to the end stop, making sure that the wall sealing plate has been fitted (3); this will ensure sealing and joining of the elements making up the kit.



When the appliance is installed in areas where very rigid temperatures can be reached, a special anti-freeze kit is available that can be installed as an alternative to the standard kit.

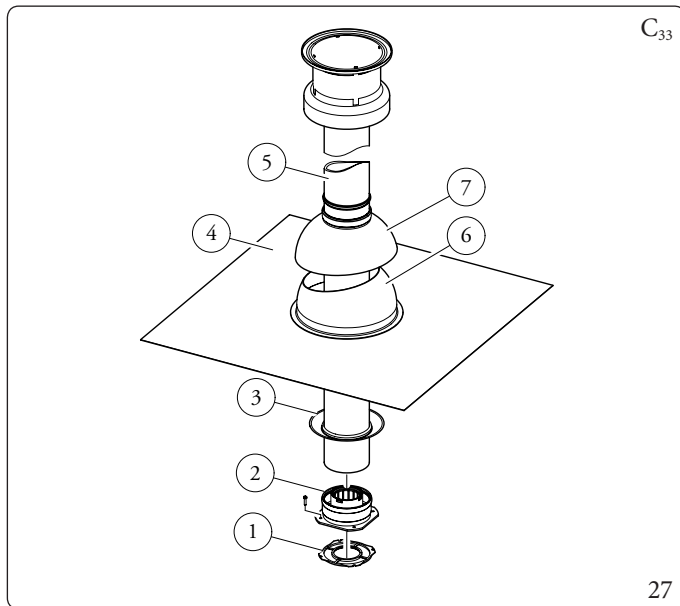

The kit includes (Fig. 27):

- N°1 Gasket (1)
- N°1 Female concentric flange (2)
- N°1 Wall sealing plate (3)
- N°1 Aluminium slate (4)
- N°1 Concentric intake/exhaust pipe Ø 60/100 (5)
- N°1 Fixed half-shell (6)
- N°1 Mobile half-shell (7)



Extensions for vertical kit Ø 60/100 (L = Equivalent length - L max = Maximum length) (Fig. 28).



The maximum lengths ((L max) of the various flues that can be installed are given in the summary table in parag. 1.15.

Key Fig. 28:

- T1 - Concentric pipe Ø60/100
- TS - Concentric intake/exhaust terminal Ø60/100
- L - Equivalent length
- Lmax - Maximum length

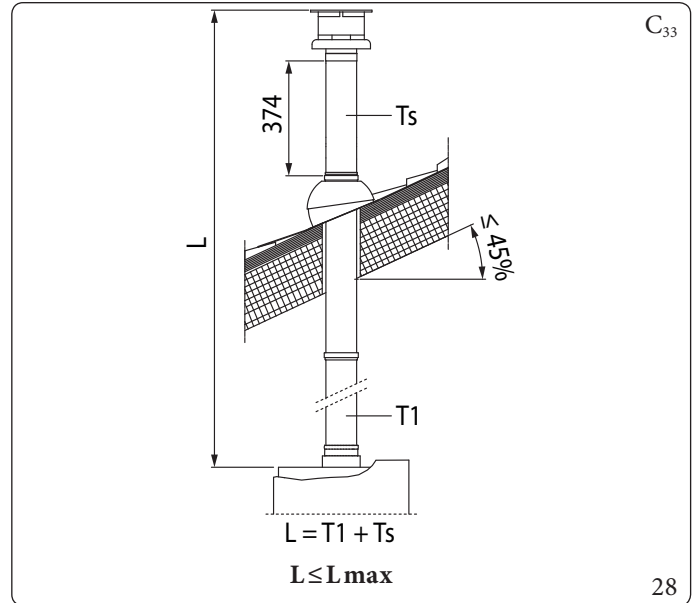

Installation examples

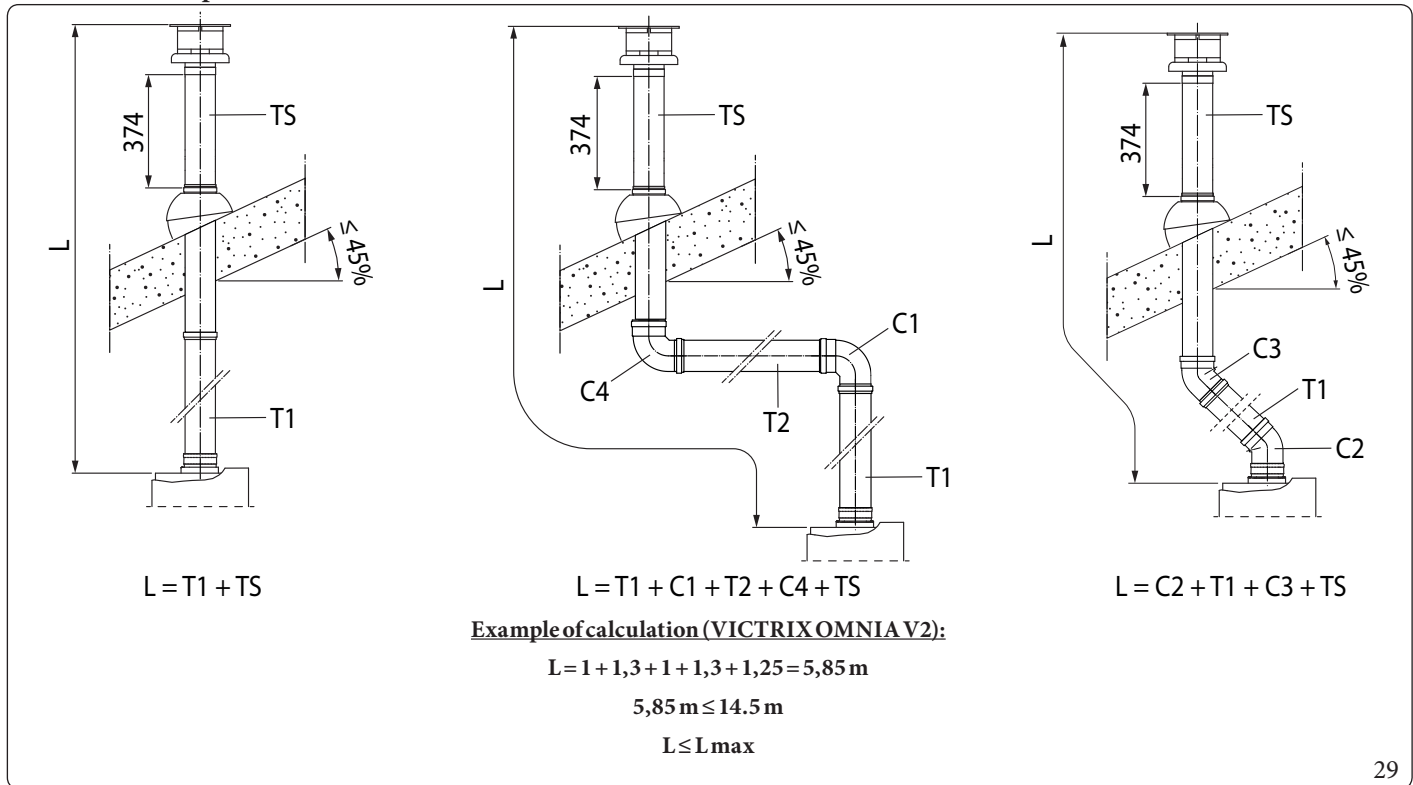

Key Fig. 29:

- T1 - Concentric pipe Ø60/100
- C1 - Ø60/100 90° concentric elbow
- T2 - Concentric pipe Ø60/100
- C2 - Ø60/100 45° concentric elbow

- C3 - Ø60/100 45° concentric elbow
- C4 - Ø60/100 90° concentric elbow
- TS - Concentric intake / exhaust terminal Ø60/100
- L - Equivalent length
- L_{max} - Maximum length



To calculate the equivalent length of the flue (L), simply add, for each component you intend to use, the corresponding value indicated in the column "Length equivalent to m of pipe" in the table in par. 1.16, and check that the resulting sum is equal to or less than the maximum length (L_{max}) indicated in par. 1.15. ($L \leq L_{\text{max}}$).

INSTALLER

USER

MAINTENANCE TECHNICIAN

TECHNICAL DATA



Vertical kit assembly with aluminium slate Ø80/125 (Fig. 30)



To install the kit Ø 80/125 one must use the adapter kit (pos. 2, Fig. 30).

1. Install the concentric flange (2) on the flue exhaust of the appliance, positioning gasket (1) with the circular projections downwards in contact with the appliance flange.

Imitation aluminium slate installation:

2. Tighten the concentric flange with the screws in the kit.
3. Replace the slates with the aluminium sheet (4), shaping it to ensure that rainwater runs off.
4. Position the fixed half-shell (5) on the aluminium slate;
5. Insert the intake-exhaust terminal (7);
6. Fit the Ø80/125 concentric terminal pipe with the male side (smooth) to the female side of the adapter (1) (with lip seals) up to the end stop, making sure that the wall sealing plate (3) has been fitted; this will ensure sealing and joining of the elements making up the kit.

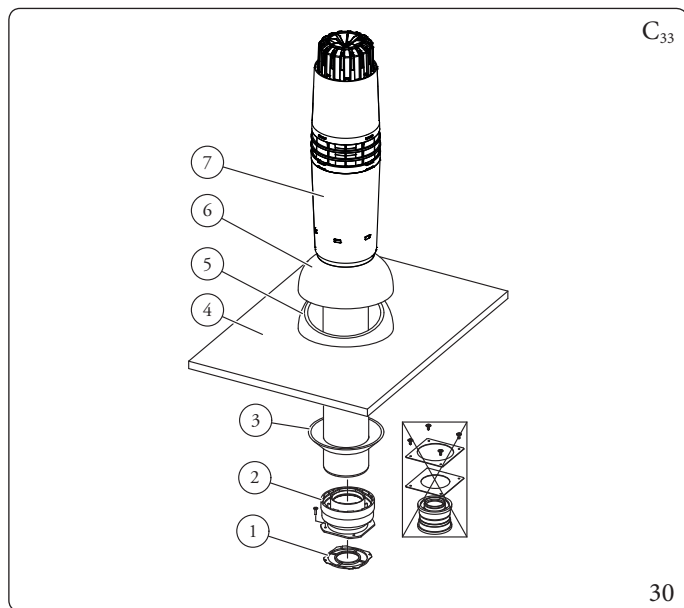

The adaptor kit includes (Fig. 30):

- N°1 Gasket (1)
- N°1 Adapter Ø80/125 (2)

The Ø 80/125 kit includes (Fig.30):

- N°1 Wall sealing plate (3)
 - N°1 Aluminium slate (4)
 - N°1 Fixed half-shell (5)
 - N°1 Mobile half-shell (6)
 - N°1 Concentric intake/exhaust pipe Ø80/125 (7)
- The remaining kit components must not be used

Extensions for vertical kit Ø 80/125 (L = Equivalent length - L max = Maximum length) (Fig. 31).



The maximum lengths ((L max) of the various flues that can be installed are given in the summary table in parag. 1.15.

Key Fig. 31:

- T1 - Concentric pipe Ø80/125
- TS - Concentric intake/exhaust terminal Ø80/125
- L - Equivalent length
- Lmax - Maximum length

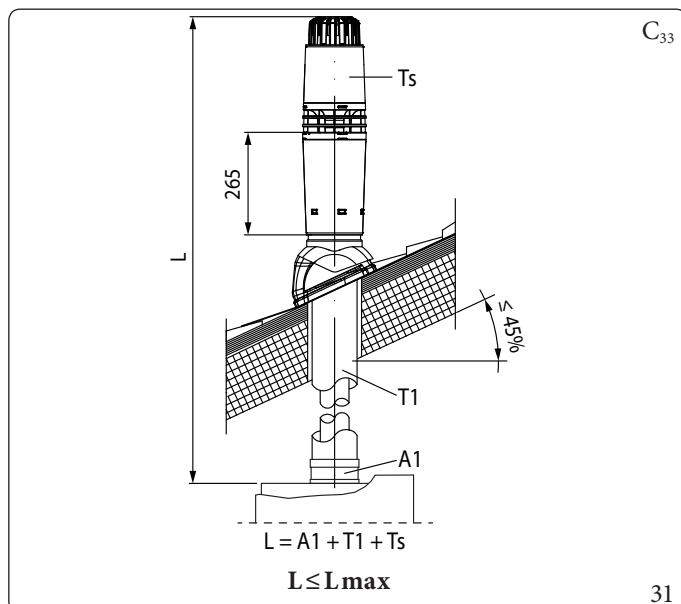

Installation examples

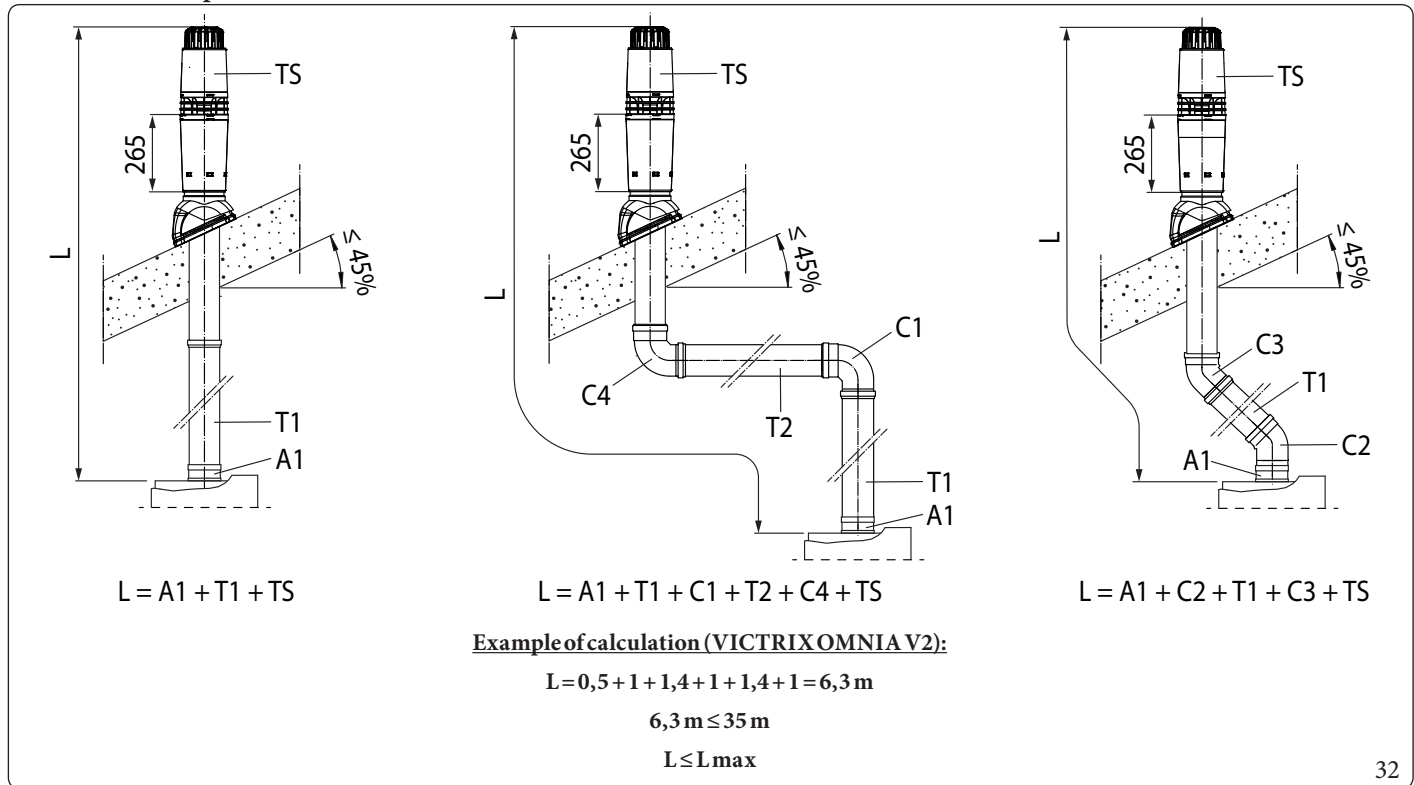

Key Fig. 32:

- T1 - Concentric pipe Ø80/125
- C1 - Ø80/125 90° concentric elbow
- T2 - Concentric pipe Ø80/125
- C2 - Ø80/125 45° concentric elbow

- C3 - Ø80/125 45° concentric elbow
- C3 - Ø80/125 90° concentric elbow
- TS - Concentric intake / exhaust terminal Ø80/125
- L - Equivalent length
- L_{max} - Maximum length



To calculate the equivalent length of the flue (L), simply add, for each component you intend to use, the corresponding value indicated in the column "Length equivalent to m of pipe" in the table in par. 1.16, and check that the resulting sum is equal to or less than the maximum length (L_{max}) indicated in par. 1.15. ($L \leq L_{\text{max}}$).

INSTALLER

USER

MAINTENANCE TECHNICIAN

TECHNICAL DATA



1.21 INSTALLATION OF VERTICAL TERMINALS Ø 80

Configuration type B, open chamber and fan assisted

Mounting the vertical kit Ø 80 (Fig. 33)

1. Install the Ø 80 terminal (2) on the central hole on the appliance up to the end stop, making sure that the wall sealing plate (1) has been fitted. This will ensure the sealing efficiency of the kit components.

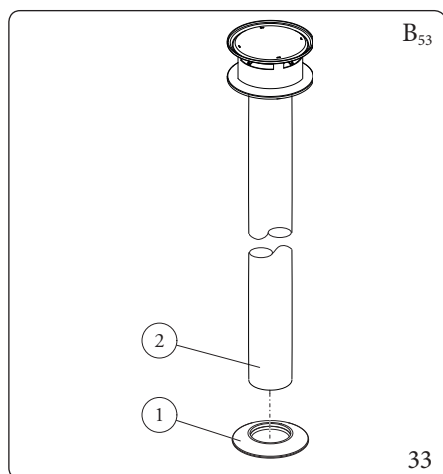

The Kit includes (Fig. 33):

- N°1 Wall sealing plate (1)
- N°1 Exhaust terminal Ø 80 (2)

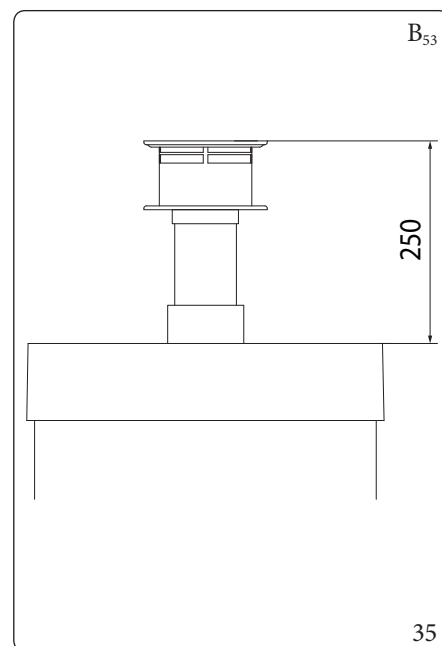
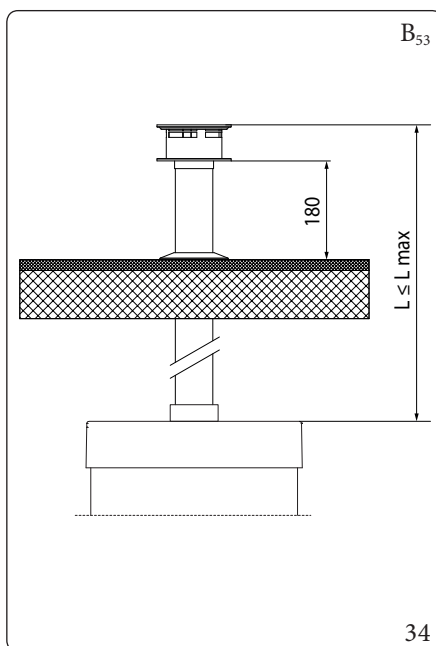

Maximum length ($L = \text{Length} - L_{\text{max}} = \text{Maximum length}$) (Fig. 34).

Using the Ø 80 vertical terminal for direct discharge of the combustion products, the terminal must be shortened (see quotas fig. 135). The wall sealing plate (1) must also be inserted in this case going up to stop on the appliance cover.



The maximum lengths (L_{max}) of the various flues that can be installed are given in the summary table in parag. 1.15.

Ø80 vertical kit installation (in stainless steel) (Fig. 36)

1. Install the Ø 80 terminal (1) on the central hole on the appliance up to the end stop, ensuring the sealing efficiency of the kit components.

The 80 Ø steel terminal is used to install the boiler outdoors with a direct exhaust. The terminal cannot be shortened and once it is installed it will extend out by 1000 mm (Fig. 37).

The Kit includes (Fig. 36):

- N°1 Steel exhaust terminal Ø 80 (1)

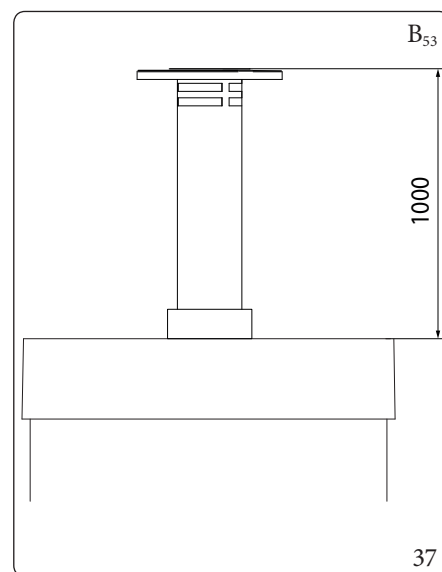
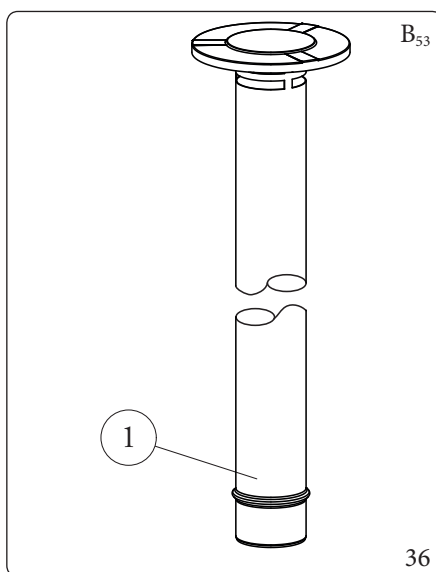

1.22 SEPARATOR KIT INSTALLATION

Type C configuration, sealed chamber and fan assisted separator kit Ø 80/80

This kit allows air to come in from outside the building and the exhaust to exit from the chimney, flue or intubated duct through divided flue exhaust and air intake pipes.

Combustion products are expelled from pipe (S) (in plastic, so as to resist acid condensate).

Air is taken in through duct (A) for combustion (this is also in plastic).

Both ducts can be routed in any direction.

Assembly of separator kit Ø 80/80 (Fig. 38):

1. Install the flange (4) on the central hole of the appliance, positioning gasket (1) with the circular projections downwards in contact with the appliance flange.
2. Tighten with the hexagonal head and flat point screws provided in the kit.
3. Replace the flat flange present in the lateral hole with respect to the central one (according to needs) with the flange (3), positioning the gasket (2) in between.
4. Tighten with the supplied self-tapping screws with drill bit.
5. Fit the bends with male side (smooth) (5) in the female side of the flanges (3 and 4).
6. Fit the intake terminal (6) with the male side (smooth) in the female side of the bend (5) up to the end stop, ensuring that the internal and external wall sealing plates are fitted
7. Fit the exhaust pipe (9) with the male end (smooth) to the female end of the bend (5) up to the end stop; making sure that the internal wall sealing plate has been fitted, this will ensure sealing and joining of the elements making up the kit.

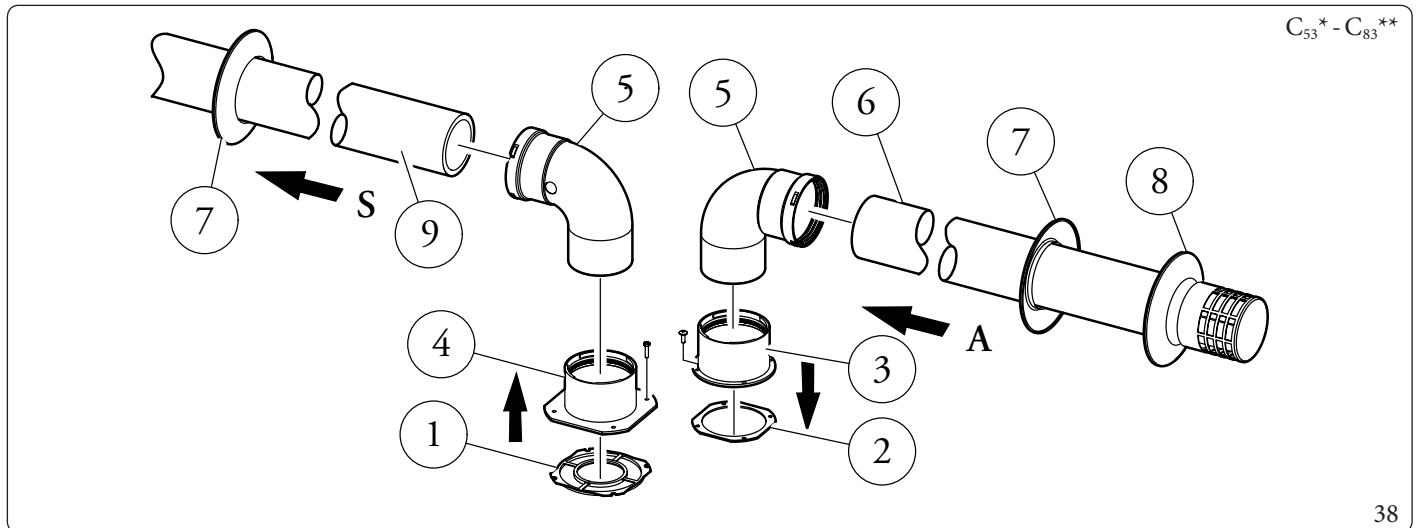

The kit includes (Fig. 38):

- N°1 Exhaust gasket (1)
- N°1 Flange gasket (2)
- N°1 Female intake flange (3)
- N°1 Female exhaust flange (4)
- N°2 Ø 80 90° bend (5)
- N°1 Intake terminal Ø 80 (6)
- N°2 Internal wall sealing plates (7)
- N°1 External wall sealing plate (8)
- N°1 Exhaust pipe Ø 80 (9)

* to complete C₅₃ configuration, also provide for a "green range" roof discharge terminal. The configuration on walls opposite the building is not allowed.

** configuration C₈ envisages connection to flues working with natural draught.



For technical data concerning the C₈ configuration, please refer to the table in par. 4.2.



Installation clearances (Fig. 39)

The minimum installation clearance measurements of the Ø 80/80 separator terminal kit have been stated in some limit conditions.

* Configuration C₄ envisages connection to flues working with natural draught.



To preserve proper operation of the appliance and in particular of its condensate drain system in the configurations C₄ - C₈, it is **not allowed** to drain the condensate coming from the existing exhaust duct in the building through the boiler.



For technical data concerning the C₄ configuration, please refer to the table in par. 4.2.

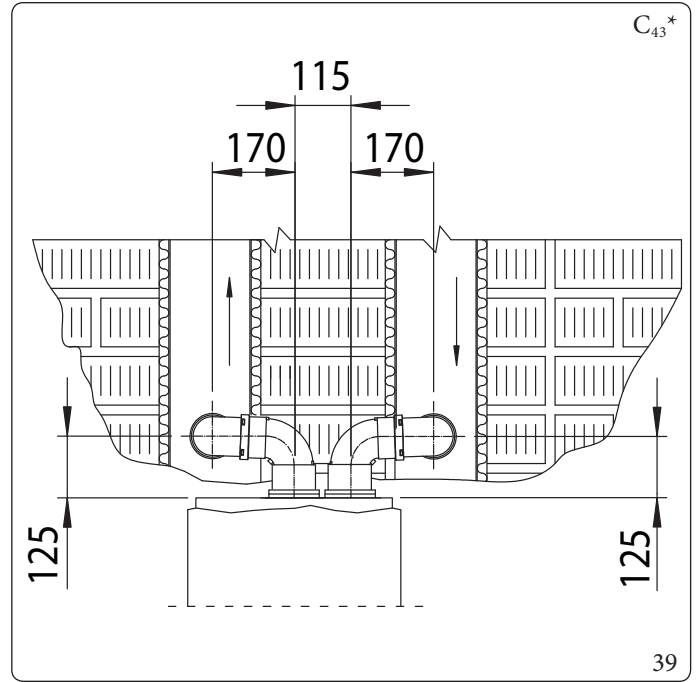

Extensions for separator kit Ø 80/80 (L = Equivalent length - L max = Maximum length).



To aid in the removal of possible condensate forming in the exhaust pipe, tilt the pipes towards the appliance with a minimum slope of 5% (Fig. 40).

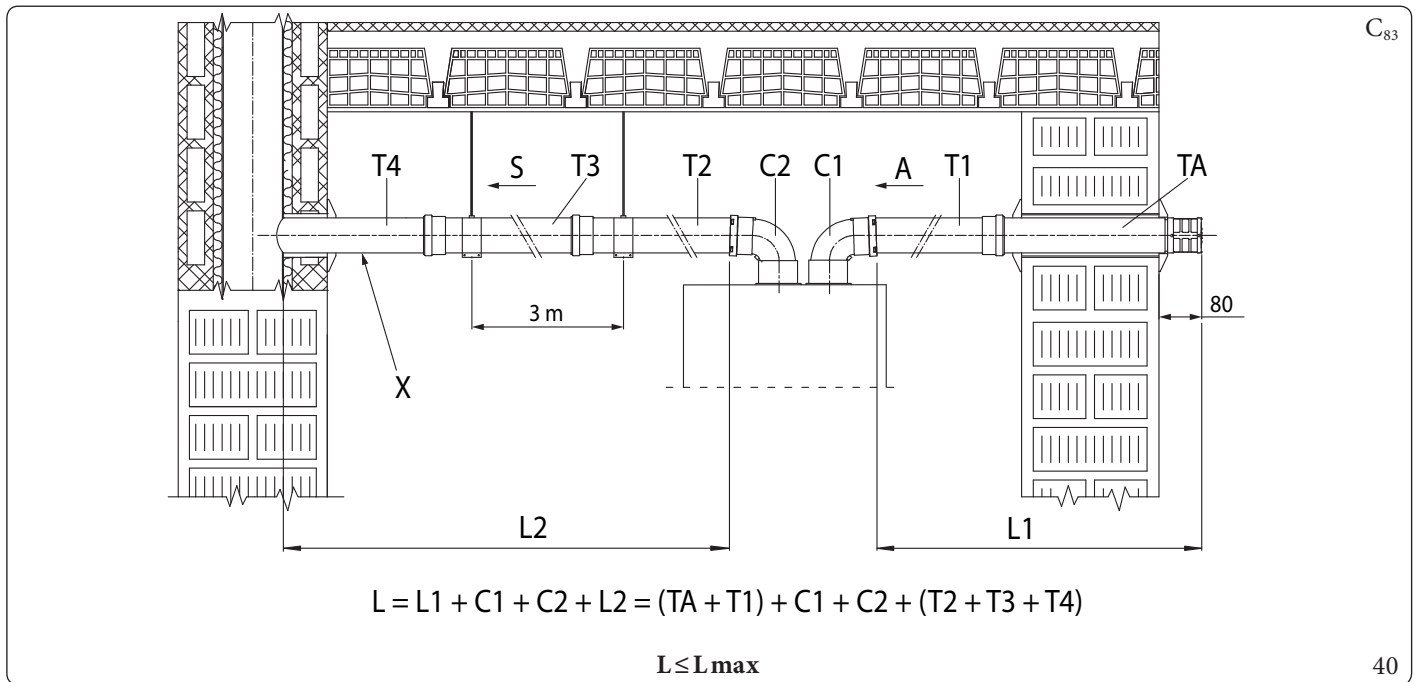

Key (Fig. 40):

- A - Intake
- X - Minimum slope 5%
- S - Exhaust
- TA - Intake terminal Ø80
- T1 - Pipe Ø80
- T2 - Pipe Ø80

- T3 - Pipe Ø80
- T4 - Pipe Ø80
- C1 - Ø80 90° elbow
- C2 - Ø80 90° elbow
- L - Equivalent length
- Lmax - Maximum length



The maximum lengths ((L max) of the various flues that can be installed are given in the summary table in parag. 1.15.



Installation examples

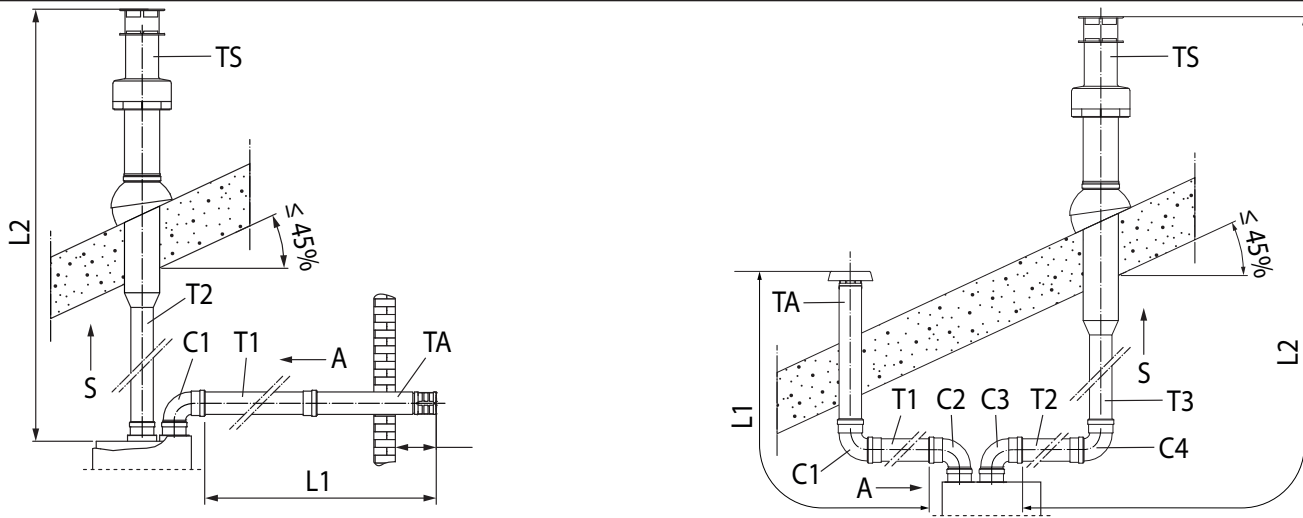

$$L = L1 + C1 + L2 = (TA + T1) + C1 + (T2 + TS)$$

$$L = L1 + C2 + C3 + L2 = (TA + C1 + T1) + C2 + C3 + (T2 + C4 + T3 + TS)$$

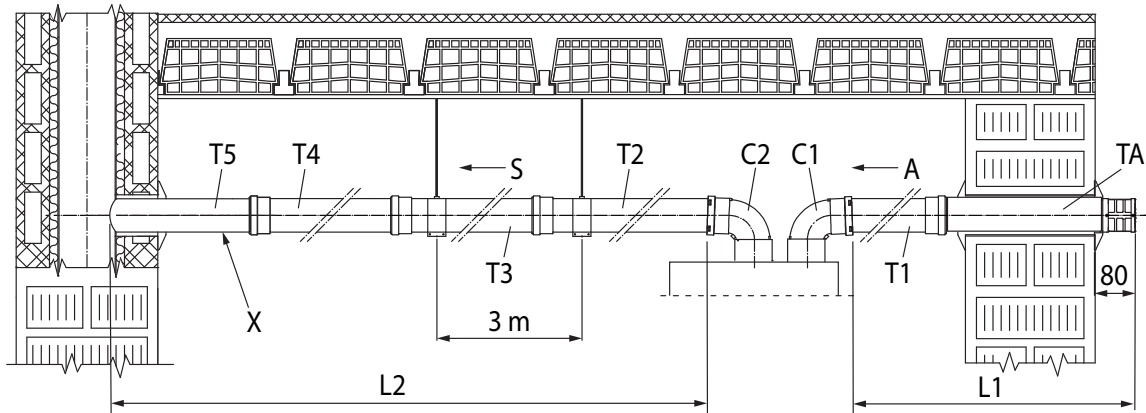

$$L = L1 + C1 + C2 + L2 = (TA + T1) + C1 + C2 + (T2 + T3 + T4 + T5)$$

Example of calculation (VICTRIX OMNIA V2):

$$L = (2,5 + 0,7) + 1,6 + 2,1 + (1 + 1 + 1 + 1) = 10,9 \text{ m}$$

$$10,9 \text{ m} \leq 35 \text{ m}$$

$$L \leq L_{\text{max}}$$

Key Fig. 41:

- TA - Intake terminal Ø80
- TS - Exhaust terminal Ø80
- T1 - Pipe Ø80
- T2 - Pipe Ø80
- T3 - Pipe Ø80
- T4 - Pipe Ø80
- T5 - Pipe Ø80
- C1 - Ø80 90° elbow

- C2 - Ø80 90° elbow
- C3 - Ø80 90° elbow
- C4 - Ø80 90° elbow
- X - Minimum slope 5%
- A - Intake
- S - Exhaust
- L - Equivalent length
- L_{max} - Maximum length



To calculate the equivalent length of the flue (L), simply add, for each component you intend to use, the corresponding value indicated in the column "Length equivalent to m of pipe" in the table in par. 1.16, and check that the resulting sum is equal to or less than the maximum length (L_{max}) indicated in par. 1.15. ($L \leq L_{\text{max}}$).



1.23 ADAPTOR KIT INSTALLATION C₉

This kit allows an Immergas appliance to be installed in C₉₃ configuration, with combustion air intake directly from the shaft where the flue gas exhaust is, obtained by means of a ducting system.

System composition

The system must be combined with the following components (sold separately) to be functional and complete:

- kit C₉₃ " Ø 100 or Ø 125 version;
- ducting kit rigid Ø 60 and Ø 80 and flexible Ø 50 and Ø 80;
- flue exhaust kit Ø 60/100 or Ø 80/125 configured according to the installation and type of appliance.

Mounting adapter kit C₉ (Fig. 42)



(Version Ø 125 only) before assembly check the gaskets are in the right position.

If component lubrication is not sufficient (applied previously by the manufacturer), remove the residual lubricant using a dry cloth, then grease the parts with the supplied lubricant in order to ease the push-fitting operations.



To aid in the removal of possible condensate forming in the exhaust pipe, tilt the pipes towards the appliance with a minimum slope of 5% (Fig. 40).

1. Mount the components of kit C₉ on the door (A) of the ducting system (Fig.42).
2. (Version Ø 125 only) mount the flanged adaptor (11) interposing the concentric gasket (10) on the appliance, fitting it with the screws (12).
3. Mount the ducting system as described in the relative instructions sheet.
4. Calculate the distances between the appliance drain and the bend of the ducting system.
5. Prepare the appliance flue system, making sure that the internal pipe of the concentric kit is fitted up to the end stop in the ducting system curve (Quota "X" Fig. 44), whereas the external pipe must reach the end stop of the adapter (1).
6. Mount the cover (A) complete with adaptor (1) and caps (6) on the wall.
7. Assemble the flue system to the ducting system.

Once all components have been assembled properly, the exhaust fumes will be expelled via the ducting system; the combustion air for normal boiler operation will be aspirated directly by the shaft (Fig. 44).

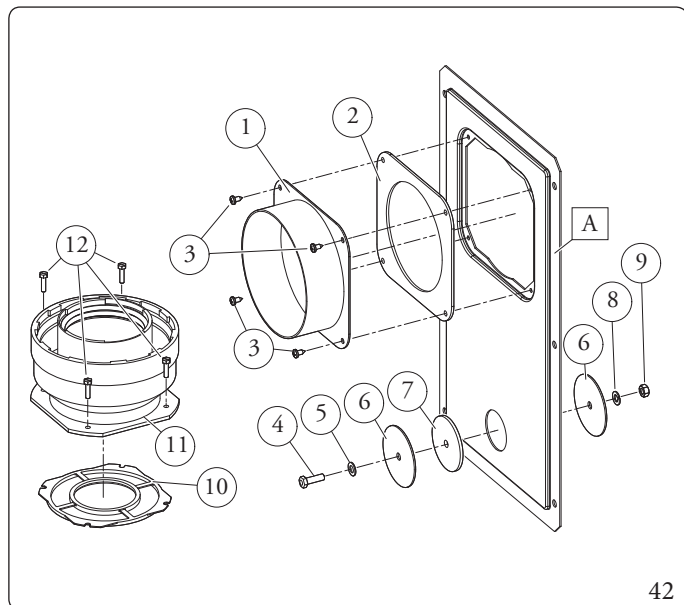

The adapter kit includes (Fig. 42):

- N°1 Door adaptor Ø 100 or Ø 125 (1)
- N°1 Door gasket made of neoprene (2)
- N°4 Screws 4.2x9 AF (3)
- N°1 Hex headed screw M6 x 20 (4)
- N°1 Flat nylon washer M6 (5)
- N°2 Door hole closure metal-sheet plate plug (6)
- N°1 Pluggasket made of neoprene (7)
- N°1 Toothed washer M6 (8)
- N°1 Nut M6 (9)
- N°1 (Ø 80/125 kit) Concentric gasket Ø 60/100 (10)
- N°1 (Ø 80/125 kit) Flanged adaptor Ø 80/125 (11)
- N°4 (Ø 80/125 kit) M4 hex headed screws x 16 slotted screwdriver (12)
- N°1 (Ø 80/125 kit) Lubricant bag

Supplied separately (Fig. 42):

- N°1 Ducting kit door (A)



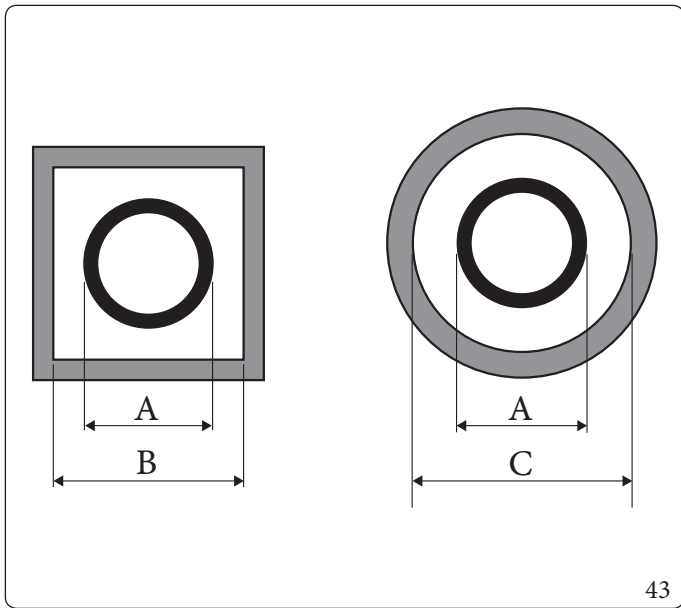

Ducting	ADAPTOR (A) mm	SHAFT (B) mm	SHAFT (C) mm
Ø60 Rigid	66	106	126
Ø50 Flexible	66	106	126
Ø80 Rigid	86	126	146
Ø80 Flexible	103	143	163

Technical data

The dimensions of the shafts must ensure a minimum gap between the outer wall of the smoke duct and the inner wall of the shaft: 30 mm for circular section shafts and 20 mm in the event of a square section shaft (Fig. 43).

Maximum 2 changes of direction are allowed on the vertical section of the flue system with a maximum clearance angle of 30° with respect to the vertical.

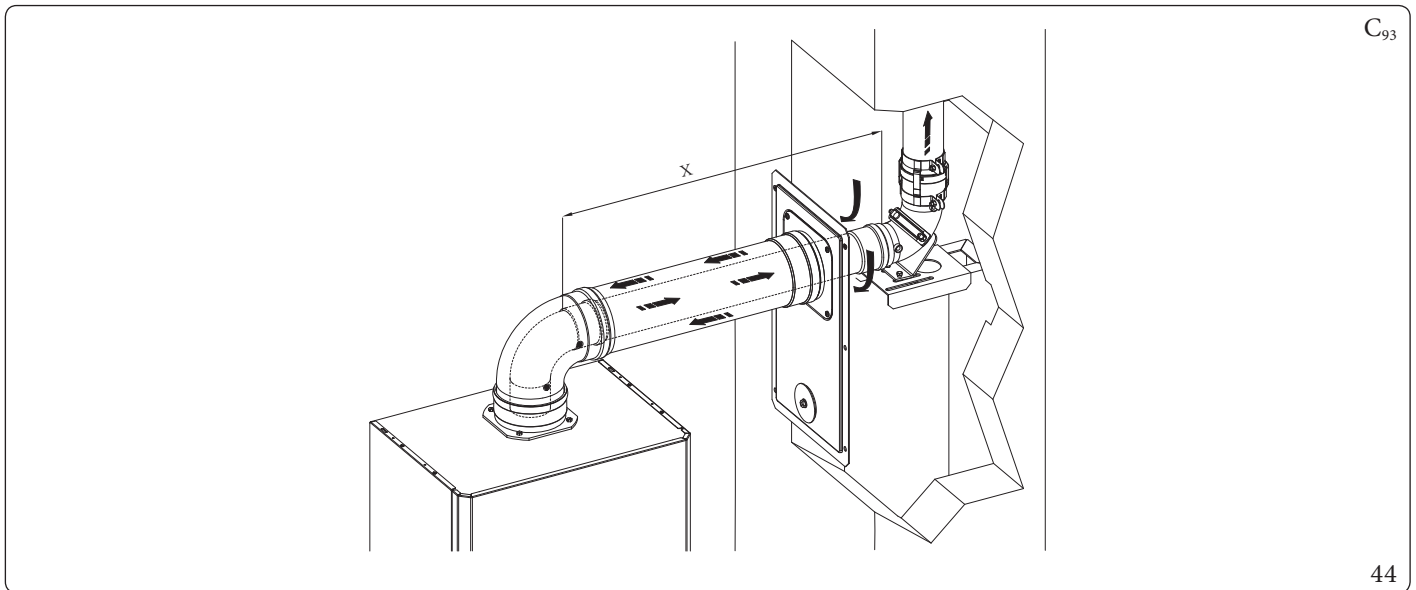

The maximum lengths ((L max) of the various flues that can be installed are given in the summary table in parag. 1.15.

INSTALLER

USER

MAINTENANCE TECHNICIAN

TECHNICAL DATA



1.24 DUCTING OF FLUES OR TECHNICAL SLOTS

Ducting is an operation through which, via the introduction of one or more relevant pipes, one achieves a system for the evacuation of the combustion products of a gas appliance, made up from the coupling of an existing or new ducting pipe with a chimney, flue or technical slot (also in new buildings) (Fig. 45).

Ducting requires ducts declared to be suitable for the purpose by the manufacturer, following the installation and user instructions, provided by the manufacturer and the requirements of the regulations in force.

Immergas ducting systems



The Ø 60 rigid, Ø 50 and Ø 80 flexible and Ø 80 rigid "Green Range" ducting systems must only be used for domestic use and with Immergas condensing boilers.

In any case, ducting operations must respect the provisions contained in the standard and in current technical regulations; in particular, the declaration of conformity must be compiled at the end of work and on commissioning of the ducted system.

The instructions in the project or technical report must likewise be followed, in cases provided for by the standard and current technical regulations.

To guarantee reliability and operation over time of the ducting system, make sure:

- it is used in average atmospheric and environmental conditions, according to current regulations (absence of combustion products, dusts or gases that can alter the normal thermophysical or chemical conditions; existence of temperatures coming within the standard range of daily variation, etc.).
- Installation and maintenance must be performed according to the indications supplied by the manufacturer included with the "green range" ducting system chosen and in compliance with the regulations in force.
- To guarantee long-time reliability and functionality of the ducting system, the maximum length specified by the manufacturer (Par. 1.15) must be complied with.

In flexible and rigid ducting configurations C₅₃, the maximum length (L_{max}) does not include the 3 elbows and the exhaust terminal. They must therefore be considered when calculating the equivalent length (L).



The maximum lengths ((L_{max}) of the various flues that can be installed are given in the summary table in parag. 1.15.

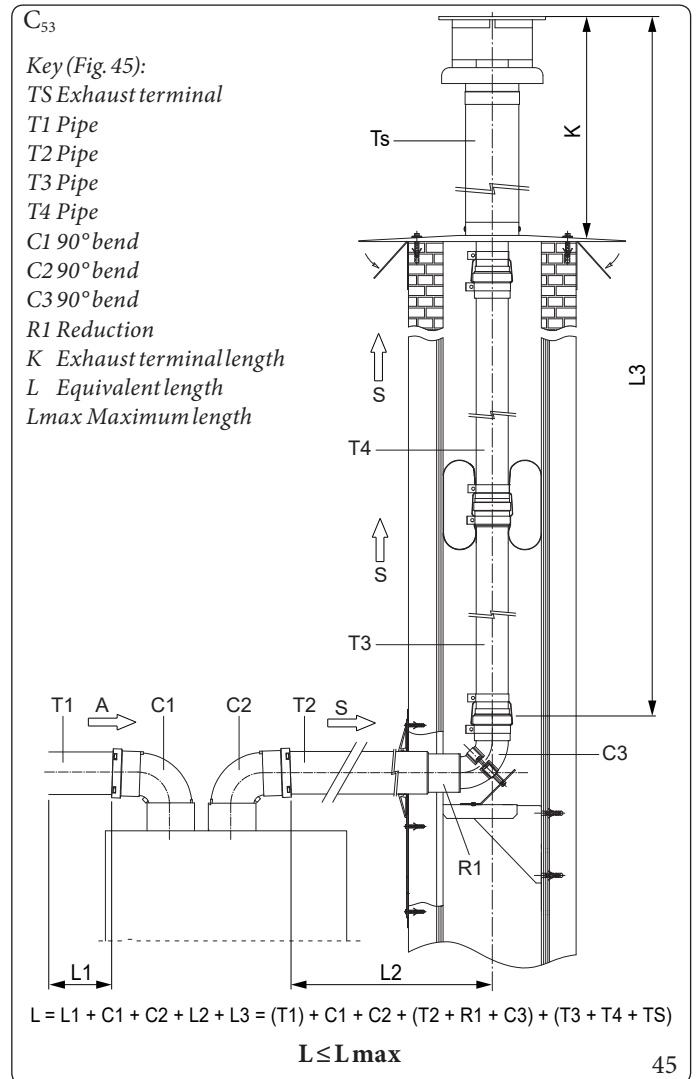

Exhaust terminal lengths table

Ducting type	Terminal	K(m)
Ø 50 Flexible	Terminal with 90° bend kit	0,27
	T terminal kit	0,16
	Ø80/125 vertical terminal kit	0,48
Ø60 Rigid	Concentric vertical terminal kit Ø60	0,49
Ø 80 flexible	Ø80/125 vertical terminal kit	0,48
Ø80 rigid	Concentric vertical terminal kit Ø80	0,65

1.25 CONFIGURATION C₍₁₅₎₃ CONCENTRIC KIT

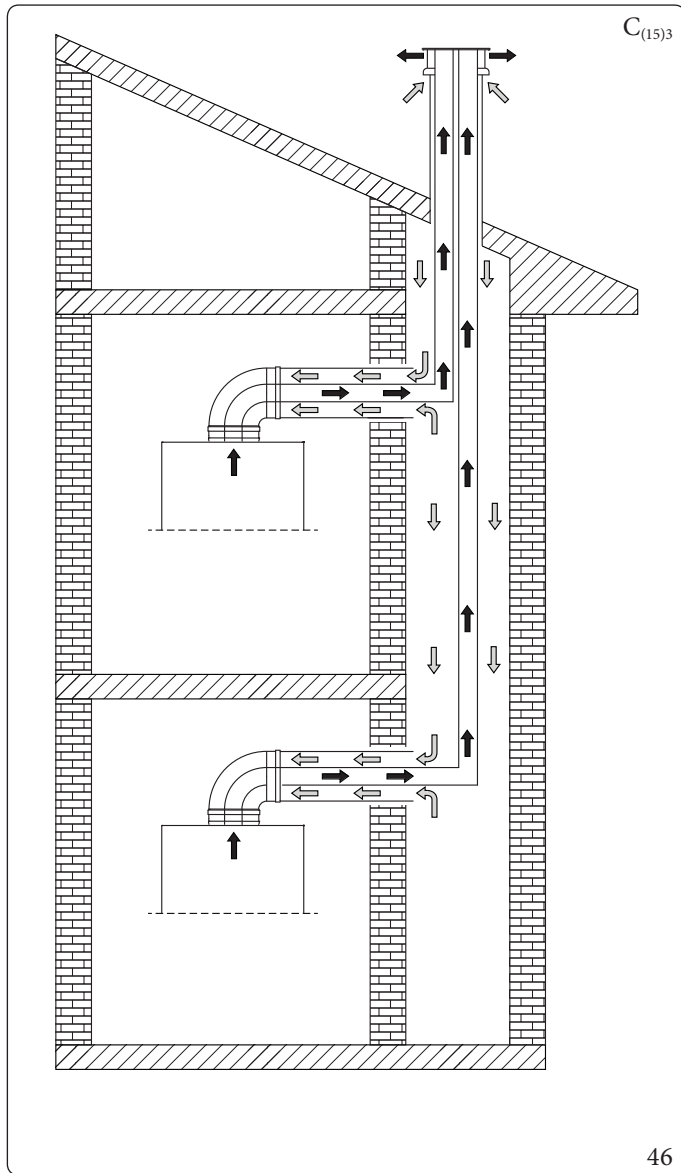

Installation in C₍₁₅₎₃ configuration of an Immergas appliance, makes it possible to extract combustion air directly from the shaft where the flue gas exhaust is present in the dedicated flue.

Information for C₍₁₅₎₃ installations

The appliance is suitable for operating in a C₍₁₅₎₃ or C_{(15)3X} system, correctly sized by a thermotechnical designer.

The roof terminal, which is an integral part of the project, must also meet the legislative and regulatory obligations prescribed for this component. In particular, it must ensure that the degree of recirculation of the flue gas is always below 10%.

The common supply shaft must be sized so that, in combination with the intake part of the roof terminal, a vacuum greater than 5 Pa is not generated at the point of the shaft where the appliance draws the combustion air from the shaft itself, when the appliance works at maximum heat output and the entire multiple ducting system works at maximum design power.

If the single terminal complies with the following head losses conditions at the maximum appliance heat input:

Model	Pa
Victrix Omnia V2	10

in compliance with the conditions described above, the maximum extensions that can be achieved in the shaft are those defined in this manual with C₉₃ configuration, using the same appliance settings.

INSTALLER

USER

MAINTENANCE TECHNICIAN

TECHNICAL DATA



1.26 CONFIGURATION C₍₁₀₎₃ CONCENTRICKIT (Ø 80/125)

INSTALLER



In the C₍₁₀₎₃ installations, the appliance flue exhaust must be fitted with a flue gas non-return valve kit, supplied by Immergas as an optional, consisting of the valve itself with instructions, specification and relative sticker with additional safety information (Fig.47).

USER

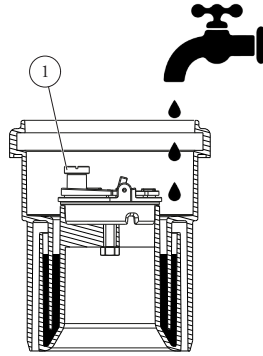

47

MAINTENANCE TECHNICIAN

TECHNICAL DATA

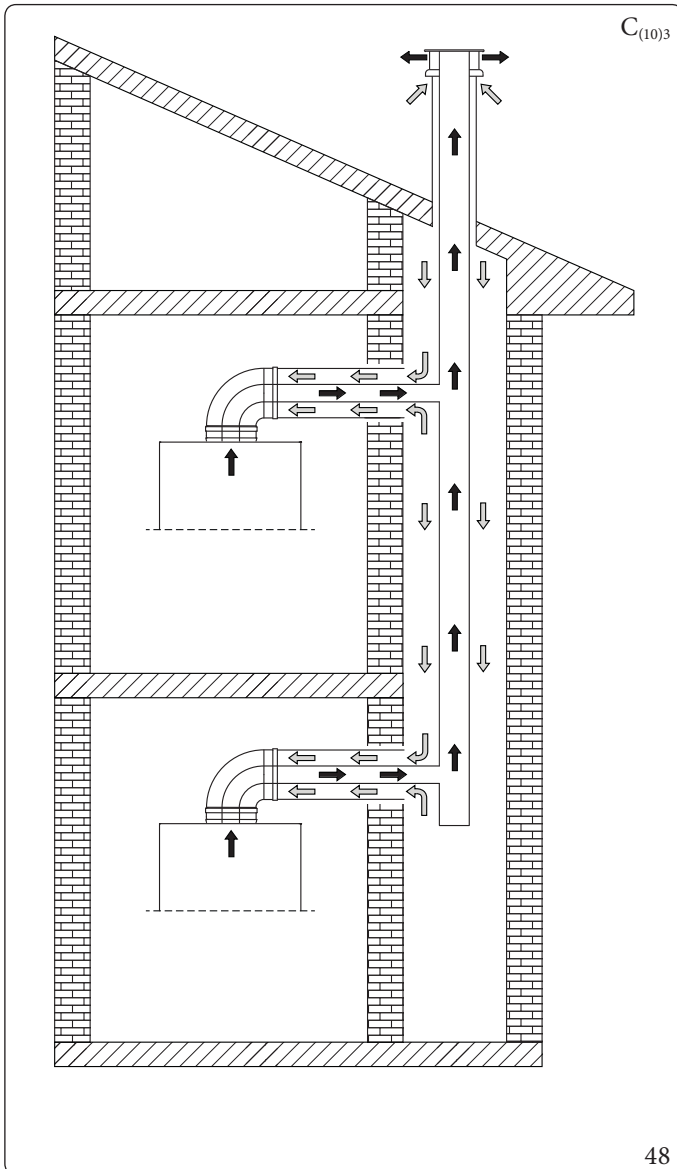

48

Installation in C₍₁₀₎₃ configuration of an Immergas appliance (only permitted with type-approved original flue, including the specific non-return valve), makes it possible to extract combustion air directly from the shaft where the flue gas exhaust is present in the collective flue.



Coupling to the shaft for intake is possible with male flue Ø 125 or Ø 125 cut female.

The collective flue coupling for the exhaust is possible with female Ø 80 flue with gasket (Fig. 50).



Concentric kit assembly in C₍₁₀₎₃ configuration (Fig. 50)



To aid in the removal of possible condensate forming in the exhaust pipe, tilt the pipes towards the appliance with a minimum slope of 5% (Fig. 49)



Before installation, in the absence of a shut-off flue adjusting device at the coupling point of the flue in the pressurised collective flue, it will be necessary to turn off all the boilers connected to the pressurised collective flue itself, or make sure to intercept the connection point to avoid the dispersion of combustion products into the environment.

1. Position the flanged adaptor (14) interposing the concentric gasket (15) on the appliance, fitting it with the screws (13) (see Fig. 50).
2. Maintain the counter weight supplied as per standard (h. 3,5 mm) mounted on the large flap of the valve and discard the one supplied bulk (h. 6,5 mm) inside of the kit (Ref. 1, Fig. 47).
3. Insert the non-return valve kit on flue gas Ø80 in the flanged adapter, taking care to remove the spacer Ø 80 th. 5 mm (see Fig. 50).



Make sure to fill the flue gas non-return valve siphon with water (Fig. 47):

4. Fit the Ø 125 extension in the flanged adapter.
5. Insert the Ø 80/125 bend on the non-return valve.
6. Calculate the distances between the bend and the connection to the collective flue and the shaft.
7. Adapt the extension (10), calculating that the inner pipe of the concentric kit must fit as far as it will go into the collective flue. The outer pipe must engage up to the door.



Before mounting it, ensure that the gaskets are in the correct position.

If component lubrication is not sufficient (applied previously by the manufacturer), remove the residual lubricant using a dry cloth, then grease the parts with the supplied lubricant in order to ease the push-fitting operations.

8. Mount the cover (A) complete with adaptor (1) and caps (6) on the wall.
9. Assemble the flue to the collective flue exhaust system.
10. Set parameter F.1 = 1.
11. Carry out the quick calibration procedure (Par. 3.11).

Once all components have been assembled properly, the exhaust flue gas will be expelled in the collective flue, the combustion air for normal appliance operation will be aspirated directly by the shaft (Fig. 44).

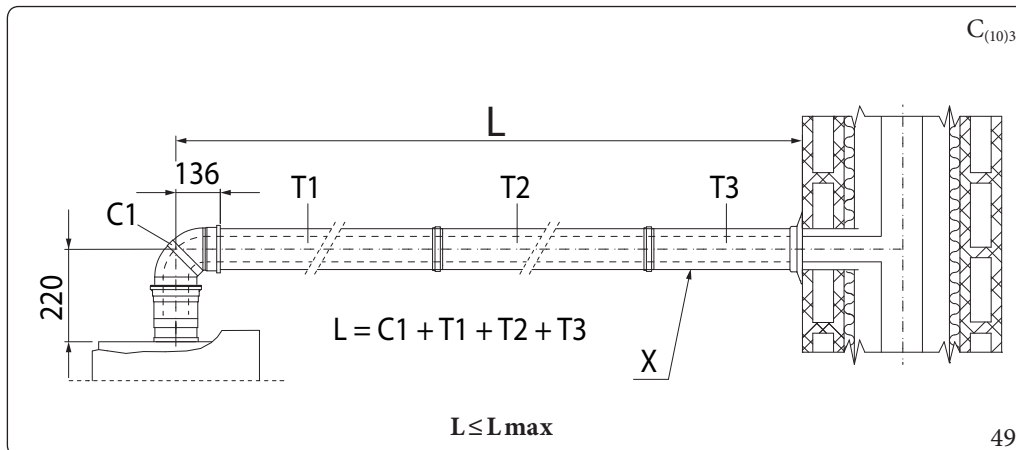

Key (Fig. 49):

- X - Minimum slope 5%
- C1 - 90° elbow Ø80/125
- T1 - Pipe Ø80/125
- T2 - Pipe Ø80/125
- T3 - Pipe Ø80/125
- L - Equivalent length
- Lmax - Maximum length



The maximum lengths ((L max) of the various flues that can be installed are given in the summary table in parag. 1.15.



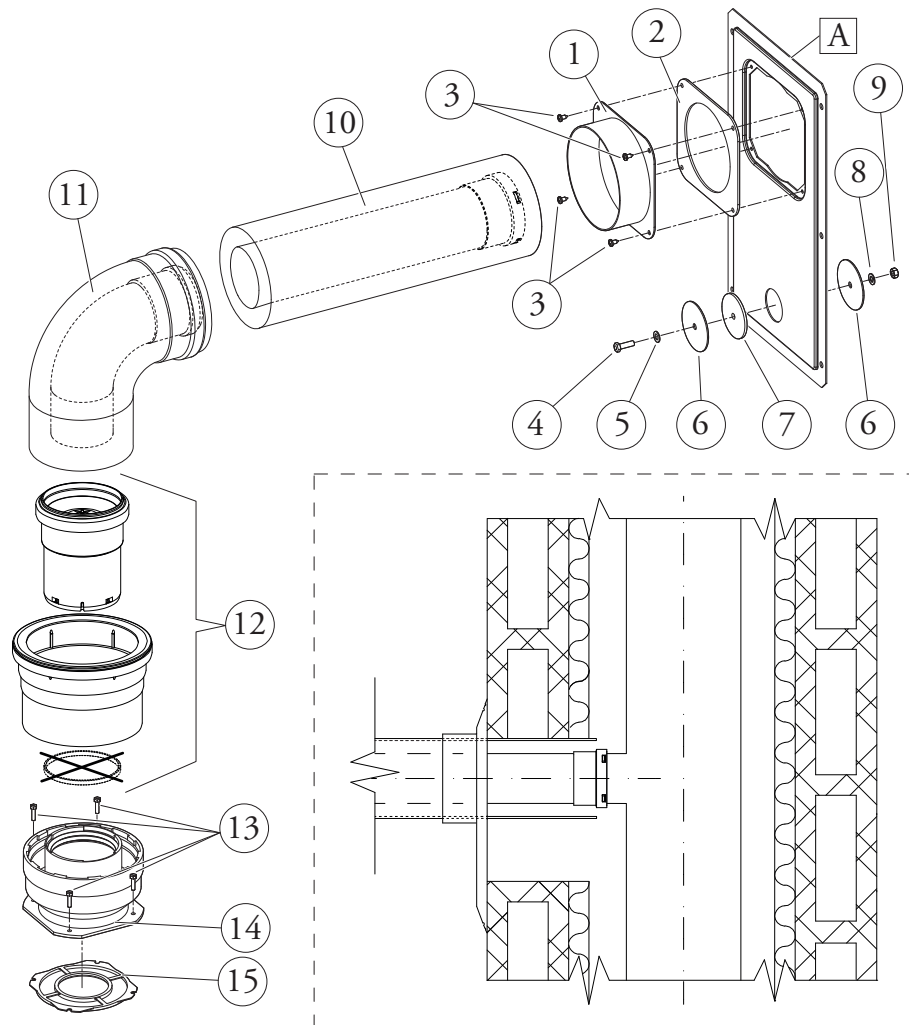

50

Key (Fig. 50):

The $C_{(10)3}$ adaptor kit includes:

- 1 Door adaptor $\text{\O} 100$ or $\text{\O} 125$ (1)
- No.1 Door gasket made of neoprene (2)
- No.4 Screws 4.2x9ST (3)
- No.1 Hex headed screw M6 x 20 (4)
- No.1 Flat nylon washer M6 (5)
- No.2 Door hole closure metal-sheet plate plug (6)
- No.1 Pluggasket made of neoprene (7)
- No.1 Toothed washer M6 (8)
- No.1 M6 nut (9)

The $\text{\O} 80/125$ extension pipe kit includes:

- 1 Extension pipe unit $\text{\O} 80/125$ (10)

The bend kit $\text{\O} 80/125$ includes:

- 1 Concentric bend $\text{\O} 80/125$ at 87° (11)

The non-return valve kit on the flues $\text{\O} 80$ (12) includes:

- 1 Gasket $\text{\O} 80$
- 1 Non-return valve on flues $\text{\O} 80$
- 1 Extension $\text{\O} 125$
- 1 Spacer $\text{\O} 80$ th. 5 mm (to be excluded for this configuration)
- No.1 Information sticker
- 1 Counterweight 6.5 mm (to be excluded, as standard counterweight h 3.5 mm is already used)

The adaptor kit includes:

- 4 (kit $\text{\O} 80/125$) M4 hex headed screws x 16 slotted screwdriver (13)
- 1 (kit $\text{\O} 80/125$) Flanged adapter $\text{\O} 80/125$ (14)
- 1 (kit $\text{\O} 80/125$) Concentric gasket (15)

Supplied separately (Fig. 50):

- No.1 Ducting kit door (A)



1.27 CONFIGURATION $C_{(10)3}$ - $C_{(12)3}$ SEPARATOR KIT ($\varnothing 80/80$)



In the $C_{(10)3}$ and $C_{(12)3}$ installations, the appliance flue exhaust must be fitted with a flue gas non-return valve kit, supplied by Immergas as an optional, consisting of the valve itself with instructions, specification and relative sticker with additional safety information (Fig.47).

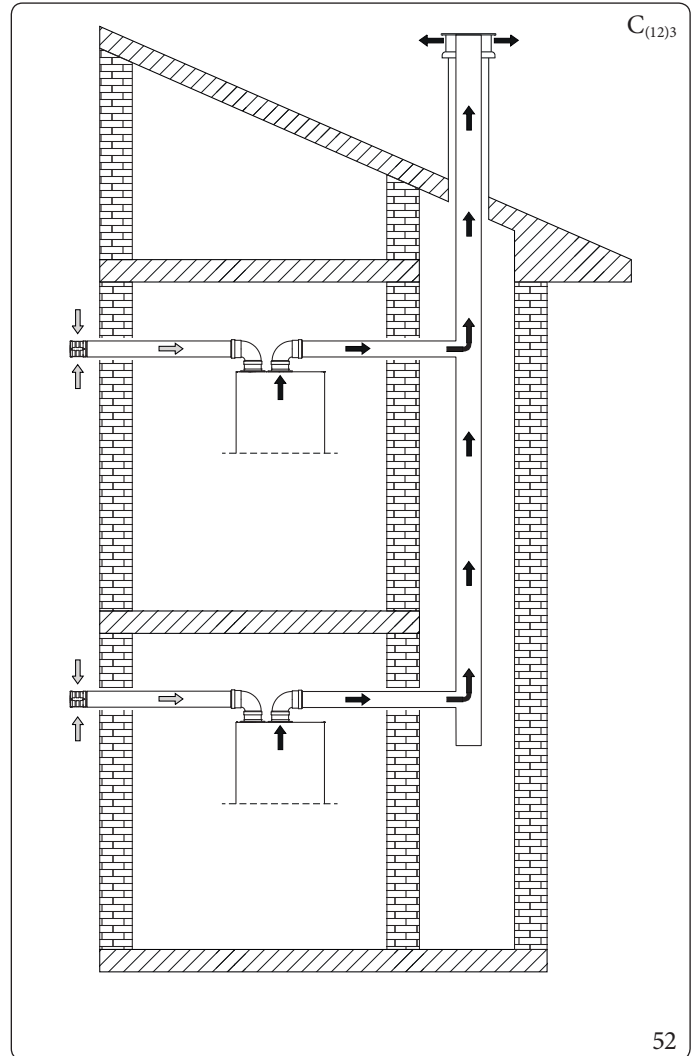
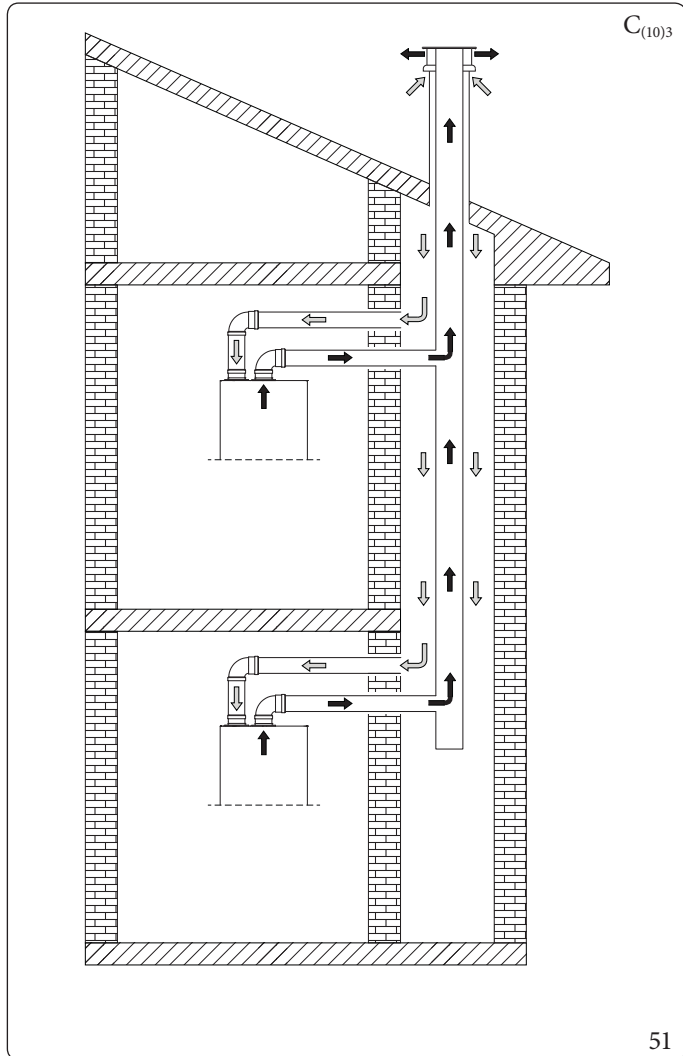

INSTALLER

USER

MAINTENANCE TECHNICIAN

TECHNICAL DATA



This configuration (allowed only with the approved original flue, including the specific non-return valve), makes it possible to suck the air outside the home or directly from the shaft where the flue gas exhaust is present and the evacuation of the flue gas itself inside a collective flue.



$C_{(10)3}$ (Fig. 51):

Coupling to the shaft for intake is possible with male flue $\varnothing 80$ or $\varnothing 80$ cut female.

$C_{(10)3} - C_{(12)3}$ (Fig. 51 - 52)

The collective flue coupling for the exhaust is possible with female $\varnothing 80$ flue with gasket.

Assembly of separator kit $\varnothing 80/80$ (Fig. 53):



Before installation, in the absence of a shut-off flue adjusting device at the coupling point of the flue in the pressurised collective flue, it will be necessary to turn off all the boilers connected to the pressurised collective flue itself, or make sure to intercept the connection point to avoid the dispersion of combustion products into the environment.

1. Install the discharge flange (4) on the appliance sample point flange, positioning the relative gasket (1) with the circular projections downwards in contact with the appliance flange, and tighten using the hex screws with flat tip contained in the kit.
2. Remove the flat flange present in the intake hole and replace it with the intake flange (3), positioning the gasket (2) contained in the separator kit $\varnothing 80/80$ and tighten using the supplied self-threading screws.
3. Eliminate the extension $\varnothing 125$ from the non-return valve kit on the flue gas.
4. Insert the spacer $\varnothing 80$ th. 5 mm into the flue exhaust flange.
5. Maintain the counterweight supplied as per standard (h. 3,5 mm) mounted on the large flap of the valve and discard the one supplied bulk (h. 6,5 mm) inside of the kit (Ref. 1, Fig. 47).
6. Insert the flue gas non-return valve on the $\varnothing 80$ flues inside the flue exhaust flange.



Make sure to fill the flue gas non-return valve siphon with water (Fig. 47):

7. Fit the bends with male side (smooth) (5) in the female side of the flanges (3 and 4).
8. For intake from shaft ($C_{(10)3}$) i.e. from common intake duct, connect the intake ducts $\varnothing 80$ (6) to the bend (5), making sure that the internal wall sealing plate (7) has already been inserted. For wall intake ($C_{(12)3}$), fit the intake terminal (6) with the male side (smooth) in the female side of the bend (5) up to the end stop, ensuring that the internal (7) and external (8) wall sealing plates are fitted.
9. Connect the $\varnothing 80$ drain pipe making sure to have already inserted the internal wall sealing plate (7) inside the end section of the pipe.
10. Set parameter F.1 = 1.
11. Carry out the quick calibration procedure (Par.3.11).



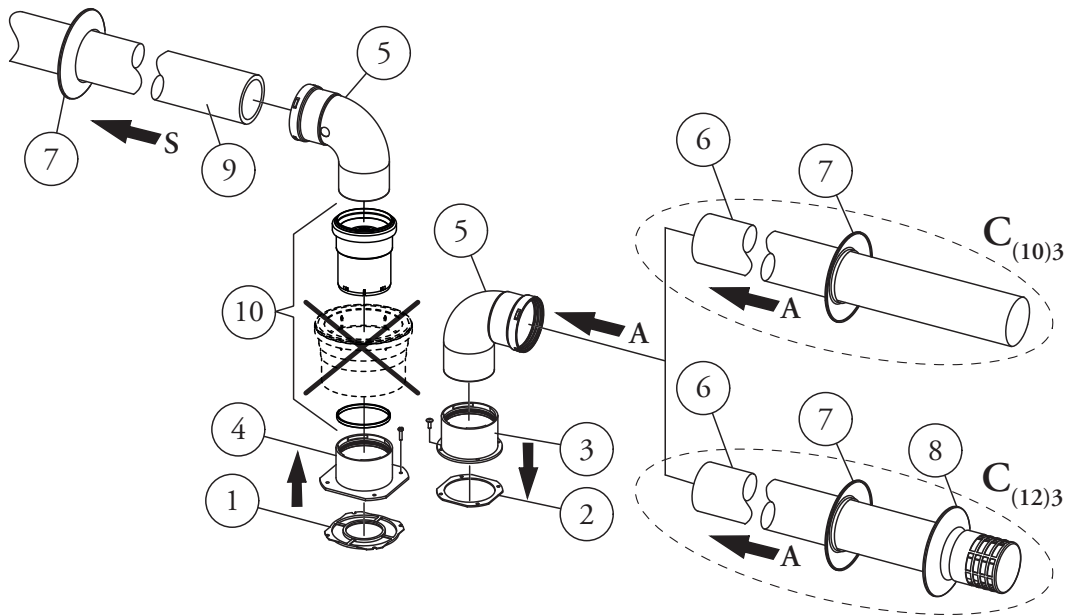

The kit includes (Fig. 53):

No.1 Exhaust gasket (1)

No.1 Flange gasket (2)

No.1 Female intake flange (3)

No.1 Female exhaust flange (4)

No.2 Bend 90° Ø 80 (5)

1 Extension Ø 80 (6) (only C₍₁₀₎₃)

1 Intake terminal Ø 80 (6) (only C₍₁₂₎₃)

No.2 Internal wall sealing plates (7)

1 External wall sealing plate (8) (only C₍₁₂₎₃)

No.1 Exhaust pipe Ø 80 (9)

N°1 Non-return valve on flue gas Ø 80 (10)

N.B.: remove extension Ø 125



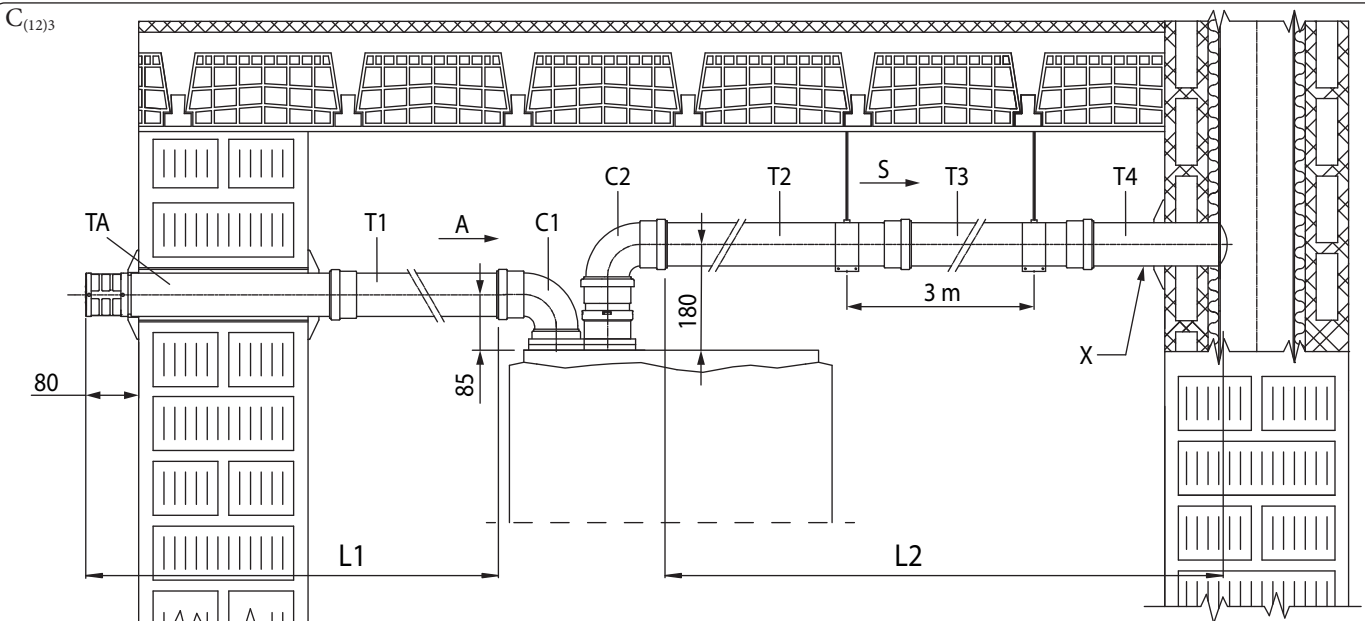
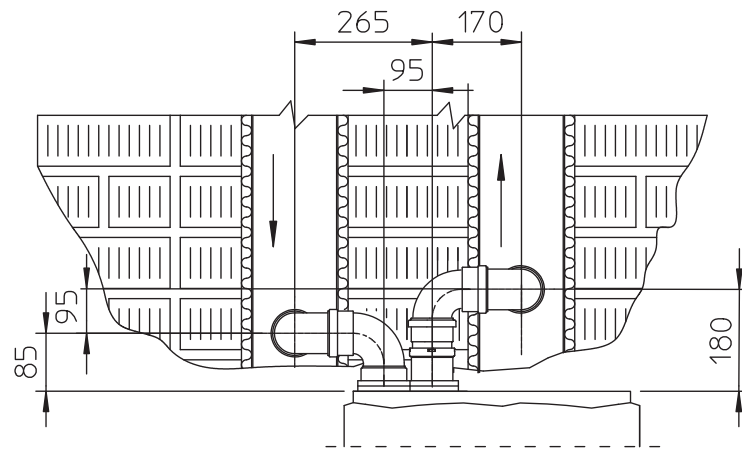

$$L = L1 + C1 + C2 + L2 = (TA + T1) + C1 + C2 + (T2 + T3 + T4)$$

$$L \leq L_{max}$$

Key (Fig. 55):

- A - Intake
- X - Minimum slope 5%
- S - Exhaust
- TA - Intake terminal Ø80
- T1 - Pipe Ø80
- T2 - Pipe Ø80

- T3 - Pipe Ø80
- T4 - Pipe Ø80
- C1 - Ø80 90° elbow
- C2 - Ø80 90° elbow
- L - Equivalent length
- L_{max} - Maximum length



The maximum lengths ((L_{max}) of the various flues that can be installed are given in the summary table in parag. 1.15.



Information for installations C₍₁₀₎₃ and C₍₁₂₎₃



The appliance is suitable for operation in a C₍₁₀₎₃ or C₍₁₂₎₃ system only with the supply of methane gas (2H and 2E categories).

The appliances are developed to operate on collective pressurised flues with a safety pressure at the minimum heat input of 25 Pa and a safety pressure at the maximum heat input of 100 Pa.



In boilers installed in flue systems type C₍₁₀₎₃ or C₍₁₂₎₃, the parameter "Presence of clapet valve on flue gas" (F.1 = 1) must be enabled, which will require automatic calibration. This is the only calibration operation permitted as CO₂ emission levels are affected by the operating pressures induced in the collective flue, with particular reference to the minimum heat input or any recirculation phenomena induced by the flue system.

The appliance must be connected to a flue system designed by a heating engineer in compliance with the local regulation in force. The collective flue system must be suitably sized to allow the appliance to operate with the following specifications with which it was designed:

- the maximum pressure, when n-1 appliance is working at maximum heat input (with n= number of total appliances connected or that can be connected to the same collective duct), and a boiler works at minimum heat input, is 25 Pa;
- the minimum pressure difference allowed between the combustion product outlet and the combustion air inlet is -200 Pa (- 400 Pa for C₍₁₂₎₃ including 100 Pa (-300 Pa C₍₁₂₎₃) of pressure generated by wind;
- the duct must have been sized with a nominal temperature of the combustion products of 25°C.
- the maximum allowed recirculation rate for wind action is 10%;
- the common flue must be certified to admit an overpressure of at least 200 Pa (minimum pressure class P1);
- no draught-breaker devices must be provided in the duct system.

In particular, at the coupling point to the pressurised collective flue, a plate must be visible showing at least the following technical information:

- the name and trademark of the common flue gas pipe manufacturer;
- suitability for operation with certified boilers C₍₁₀₎₃ or C₍₁₂₎₃;
- the maximum flue gas mass value allowed in kg/h;
- the dimensions of the common duct (collective pipe) for each push fit point;



The openings for combustion air and the inlet of combustion products of the pressurised collective flue must be closed and their tightness must be checked when the appliance is disconnected.

The appliance connection to the pressurised collective flue must be made as instructed, without exceeding the specific maximum extensions stated.

The flue pipe must be inclined (5% slope) towards the appliance to facilitate the evacuation of condensate.



The appliance flue gas outlet must be installed with the flue gas non-return valve kit, which ensures correct operation of the appliance and facilitates its maintenance operations.

Furthermore, the safety sticker must be affixed on the front casing. This sticker is contained in the appropriate Kit C₍₁₀₎₃ C₍₁₂₎₃, which contains the additional exhaust flue gas non-return valve, necessary for the pressurised collective flues.



It is advisable to affix the sticker in a clearly visible position on the front casing.



Summary table of information for C₍₁₀₎₃ installations (Only Methane 2E- 2H)

		VICTRIX OMNIA V2	
		Qmin	Qn max
Heat input	kW	4,1	26,8
CO ₂ % of reference [%]	%	9,0	9,0
Maximum boiler outlet pressure	Pa	25	93
Minimum boiler outlet pressure C ₍₁₀₎₃	Pa	-200	-200
Minimum boiler outlet pressure C ₍₁₂₎₃	Pa	-400	-400
Maximum flue gas flow rate	kg\h	7	44
Flue gas temperature 80°C\60°C	°C	62	75
Available head with maximum duct length	Pa	0,8	33,5
Maximum flue duct length 80\125	m	9	
Maximum flue duct length 80\80	m	10	
Boiler settings (as indicated in the instruction booklet)	-	See Par. 1.27 from point 9 on.	



1.28 CONFIGURATION FOR C₆ FLUE INSTALLATION



Appliance designed to be connected to a commercial exhaust/intake system.

Gas type		G20	G31
Flue temperature at maximum output	°C	75	75
Flue gas mass at maximum power	kg/h	44	45
Flue temperature at minimum output	°C	62	62
Flue gas mass at minimum power	kg/h	7	7
CO ₂ at Q. max.	%	9,0 (8,5 ÷ 9,5)	10,0 (9,5 ÷ 10,5)
CO ₂ a Q. minimum	%	9,0 (8,5 ÷ 9,5)	10,0 (9,5 ÷ 10,5)
Maximum head available at maximum power (maximum resistance value of the commercial flue system)	Pa	152	
Maximum head available at minimum power	Pa	4	
Maximum flue gas circuit temperature	°C	120	



- Ducts must withstand condensation (only for condensing models);
- Air intake ducts must withstand working air temperatures of up to 60°C;
- The maximum permissible percentage of flue gas recirculation in windy conditions is 10%;
- Suction and exhaust pipes cannot be installed on opposing walls;
- With flues in configuration C₆ discharge into pressurised flues is not permitted.

INSTALLER

USER

MAINTENANCE TECHNICIAN

TECHNICAL DATA



1.29 CONFIGURATION TYPE B, OPEN CHAMBER AND FAN ASSISTED FOR INDOORS

The appliance can be installed inside buildings in B₂₃ or B₅₃ mode; in this case, all technical rules and national and local regulations in force, must be complied with.

For installation the cover kit must be used, referred to in Parag. 1.17.

1.30 FLUE EXHAUST TO FLUE/CHIMNEY.

Flue exhaust does not necessarily have to be connected to a branched type traditional flue for type B appliances with natural draught (CCR).

The flue exhaust, for boiler clots installed in C configuration, can be connected to a single flue or to a multiple flue.

For B₂₃ configurations, exhaust is only allowed into individual chimney or directly into the external atmosphere via a relevant terminal, unless otherwise provided by local regulations.

The multiple flues must also only be connected to type C appliances of the same type (condensation), having nominal heat inputs that do not differ by more than 30% less with respect to the maximum that can be attached and powered by the same fuel.

The thermo-fluid dynamic features (flue flow rate, % of carbon dioxide, % humidity etc.) of the appliances attached to the same multiple flues, must not differ by more than 10% with respect to the average appliance attached.

Multiple flues must be specially designed according to the calculation method and requirements of the standards (such as UNI 13384), by professionally qualified technical staff.

Chimney or flue sections for connection of the flue exhaust pipe must comply with requisites of technical standards in force.

It is possible to replace a type C conventional device with one provided with condensation, connected to multiple flues, only if the derogation conditions established by the regulations in force have been met.

The flues, chimneys and chimney caps for the evacuation of combustion products must be in compliance with applicable standards.

1.31 FLUES, CHIMNEYS AND CHIMNEY CAPS.

The flues, chimneys and chimney caps for the evacuation of combustion products must be in compliance with applicable standards. Chimneys and roof-installed exhaust terminals must comply with the outlet height and with the distance from technical volumes set forth by the technical standards in force.

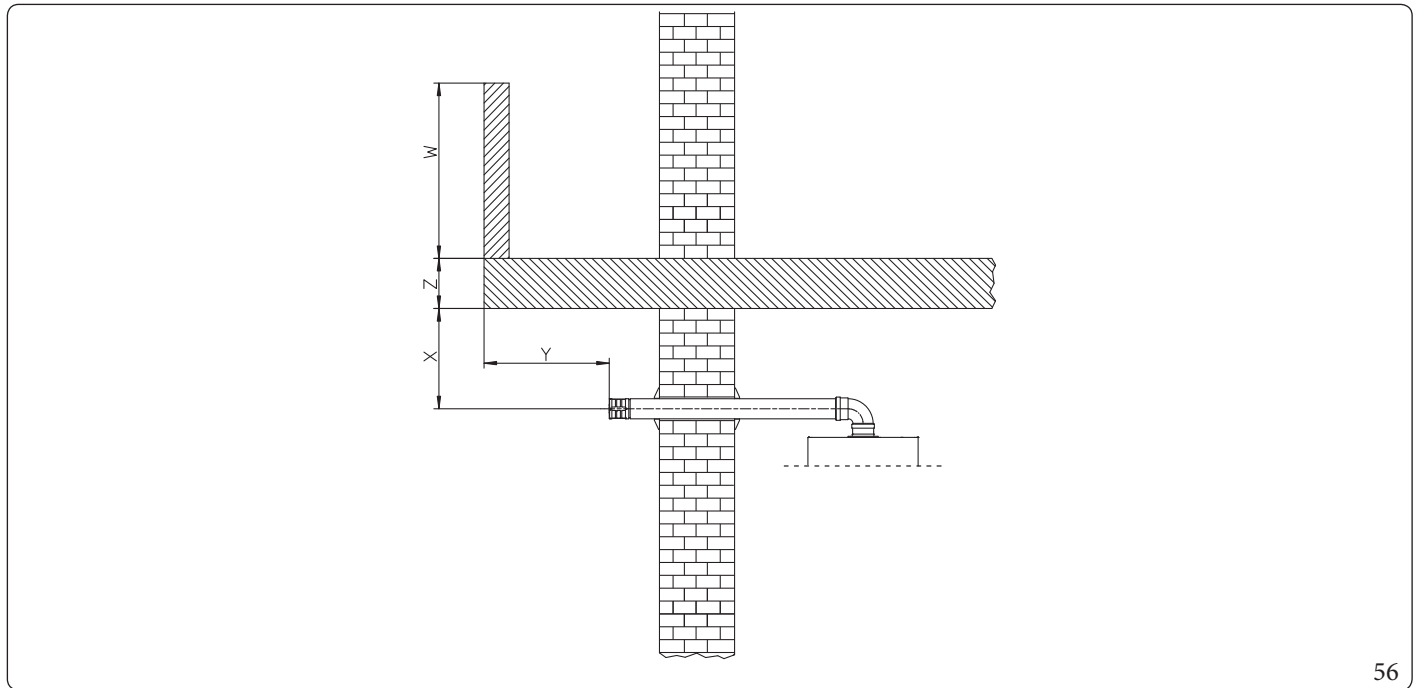

Positioning the wall flue exhaust terminals.

The wall flue exhaust terminals must:

- be installed on external perimeter walls of the building (Fig. 56);
- be positioned according to the minimum distances specified in current technical standards.

Combustion products exhaust of natural draught or fan assisted appliances in open-top closed environments.

In spaces closed on all sides with open tops (ventilation pits, courtyards etc.), direct combustion product exhaust is allowed for natural draught or fan assisted gas appliances with a heat input range from 4 to 35 kW, provided the conditions as per the current technical standards are respected.



1.32 WATER TREATMENT PLANT FILLING

The technical standard in force requires washing and treatment of the system water of the water and DHW thermal system, following the indicated methods and provisions of local standards in force.

The parameters that influence the duration and proper operation of the heat exchanger are the water's PH, total hardness, conductivity, and oxygen, together with the system's processing residues (any welding residues), any oil present and corrosion products that can, in turn, cause damage to the heat exchanger.

In order to prevent this from happening, you are recommended to:

- Before installation on new systems as well as old ones, clean the system with clean water to eliminate solid residues.
- clean the system with a chemical treatment:
 - clean the new system with a suitable cleaning device (for example Sentinel X300, Fernox Cleaner F3 or Jenaqua 300) combined with thorough washing;
 - clean the old system with a suitable cleaning device (for example Sentinel X400 or X800, Fernox Cleaner F3 or Jenaqua 400) combined with thorough washing;
- Check the maximum total hardness and amount of filling water with reference to the graph (Fig. 57), if the contents and hardness of the water are below the indicated curve, no specific treatment is required; otherwise, to limit the content of calcium carbonate, you must provide for water-filling treatment.
- If it is necessary to provide for water treatment, it should be done through complete desalination of the filling water. As opposed to the complete softening process, desalinating the water completely not only removes hardening agents (Ca, Mg), but also eliminates all other minerals to reduce water-filling conductivity up to 10 microsiemens/cm. Given its low conductivity, desalinated water does not only prevent the formation of lime scale, but also serves as protection against corrosion.
- Insert a suitable inhibitor / passivator (for example Sentinel X100, Fernox Protector F1, or Jenaqua 100); if required, also insert appropriate antifreeze (such as for example Sentinel X500, Fernox Alpha 11 or Jenaqua 500).
- Check electrical conduction of the water, which should be higher than 2000 $\mu\text{s}/\text{cm}$ in the case of treated water and lower than 600 $\mu\text{s}/\text{cm}$ in the case of non-treated water.
- To prevent corrosion, the water system's PH should be between 7.5 and 9.5.
- Check the maximum content of chlorides, which should be less than 250 mg/l.



For quantities and methods of use of water-treatment products, refer to the instructions provided by their manufacturer.

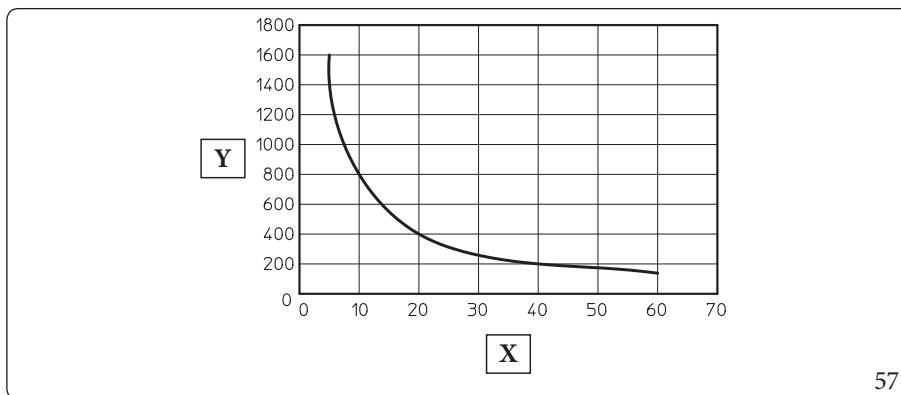

Key (Fig. 57):

- X - Total water hardness °F
- Y - Litres of system water



The graph refers to the entire life cycle of the system. Therefore, also consider scheduled and unscheduled maintenance, which involves emptying and filling the said system.



1.33 SYSTEM FILLING

1. Loosen the cap of the automatic vent valve on the circulating pump.
2. Slowly open the filling valve (Par. 1.7) to ensure release of air bubbles in the water via the appliance and central heating system vents.
3. Close the filling valve when the boiler pressure gauge indicates approx. 1.2 bar.
4. Open the radiator vent valves.
5. Close radiator vent valves when only water escapes from them.



During these operations, enable the automatic vent functions on the appliance (Parag. 3.20);

1.34 FILLING THE CONDENSATE DRAIN TRAP



When the appliance is switched on for the first time, combustion products come out of the condensate drain. After a few minutes of operation, check that combustion flue gases are no longer coming out of the condensate drain; this means that the drain trap has filled to a correct condensate height that the flue gases cannot pass through.

1.35 GAS SYSTEM START-UP

To start up the system, refer to the technical standards in force.

This divides the systems and, therefore, the commissioning operations, into three categories: new systems, modified systems, reactivated systems.

In particular, for new gas systems:

- open windows and doors;
- avoid presence of sparks or naked flames;
- bleed all air from pipelines;
- ensure the internal system is properly sealed according to the specifications set forth by technical regulations in force.



1.36 APPLIANCE START-UP (IGNITION)

To commission the appliance (the operations listed below must only be performed by qualified personnel and in the presence of staff only):

1. check that the internal system is properly sealed according to the specifications set forth by regulations in force;
2. Ensure that the type of gas used corresponds to the boiler settings (the type of gas appears on the display on first connection to the power supply, or by checking the relative parameter "G");
3. check that there is no air in the gas pipe;
4. Check connection to a 230V~50Hz power mains, correct L-N polarity and the earthing connection;
5. check that the intake/exhaust terminals are not obstructed and that they are installed properly;
6. **Check that the drain trap is full and that it prevents any passage of flue gas into the room;**
7. check that there are no external factors that may cause the formation of fuel pockets;
8. Perform the flue test and, if needed, set the correct value of the parameter "F0";
9. **Activate the quick Calibration function:**
10. Switch the appliance on and check correct ignition;
11. Check that the gas flow rate and the relative pressure values comply with those indicated in the booklet;
12. ensure that the safety device intervenes in the event of gas supply failure and check the relative intervention time;
13. Check the activation of the main switch located upstream of the appliance and in the appliance.



Even if just one single safety check provides a negative result, do not commission the system.

1.37 UPM3 CIRCULATION PUMP

During central heating mode, the Auto and Fixed operating modes are available.

- **Auto (A5 = 0):** automatic circulator pump speed and proportional head: the circulator pump speed varies according to the power supplied by the burner, the greater the power the greater the speed. Moreover, within the parameter, one can also adjust the circulator pump operating range by setting the maximum speed "A3" parameter (adjustable from 6 to 9) and the "A4" minimum speed parameter (adjustable from 6 to max set speed).
- **ΔT Constant (A5 = 5 \div 25 K):** the pump speed varies to maintain the ΔT constant between the system flow and return according to set value K (A5 = 15 Default).
- **Fixed (6 \div 9):** by setting parameters "A3" and "A4" at the same value, the pump operates at constant speed.



For the appliance to work properly, it is not allowed to drop below the minimum speed value.



In domestic hot water mode, the circulator pump always runs at full speed.

Pump LED

The LED flashes green when the pump is powered and the pwm control signal is connected.



The LED lights up steady green when the pump is powered and the signal cable disconnected. In these conditions the pump works at maximum and without control.

Alarm warnings.

If the pump detects an alarm, the LED switches from green to red; this can mean one of the following failures:

- low supply voltage;
- rotor seized;
- electrical error.

For a detailed description of the meaning of the red LED, refer to Paragraph 3.6.



The LED, in addition to being green or red, can also remain off.

It is normal for the LED to be off when the pump is not powered, whereas with the pump powered, the LED must be lit: if switched off, it means there is a fault.

Pump release.

If after a long period of inactivity, the circulator is blocked, adjust the screw in the centre of the head in order to manually release the motor shaft.

Take great care during this operation to avoid damage to the motor.

Bypass Adjustment (Parag.1.40).

The appliance leaves the factory with the bypass open.

If necessary, the by-pass can be regulated to system requirements from minimum (by-pass closed) to maximum (by-pass open).

Adjust using a flat head screwdriver, turn clockwise and open the by-pass, anticlockwise it is closed.



The bypass ensures minimum circulation of the water in the appliance and its correct operation if the systems are divided into more than one zone.



1.38 UPM4 CIRCULATION PUMP

The appliances are supplied with a variable speed circulator pump.

During central heating mode, the Auto and Fixed operating modes are available.

- **Auto (A5 = 0):** automatic circulator pump speed and proportional head: the circulator pump speed varies according to the power supplied by the burner, the greater the power the greater the speed. Moreover, within the parameter, one can also adjust the circulator pump operating range by setting the maximum speed "A3" parameter (adjustable from 6 to 9) and the "A4" minimum speed parameter (adjustable from 6 to max set speed).
- **ΔT Constant (A5 = 5 ÷ 25 K):** the pump speed varies to maintain the ΔT constant between the system flow and return according to set value K (A5 = 15 Default).
- **Fixed (6 ÷ 9):** by setting parameters "A3" and "A4" at the same value, the pump operates at constant speed.



For the appliance to work properly, it is not allowed to drop below the minimum speed value.



In domestic hot water mode, the circulator pump always runs at full speed.

Pump symbols (Fig. 58):

With the pump powered and the pwm control signal connected and operating (pump ON or in stand-by), the symbol 2 flashes green ().

If the symbol 2 turns steady green (), the pump detects no command on the pwm signal and always runs at maximum speed.

If the pump detects an alarm, symbol 1 lights up red (). This can mean that there is one of the following faults:

- Low power supply voltage.
- Rotor seized (Cautiously turn the screw in the centre of the head to manually release the motor shaft).
- Electrical error.



These anomalies will be signalled on the boiler display as errors "E60" or "E61".

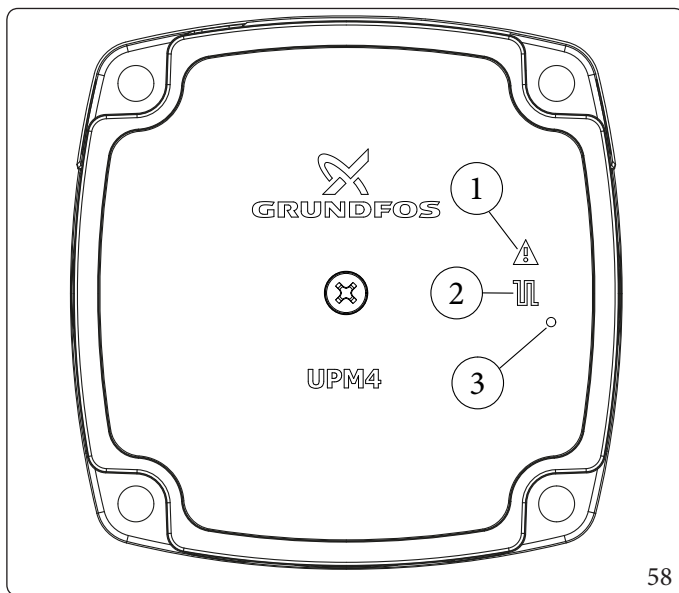

Key (Fig. 58):

- 1 - Alarm signal (Red)
- 2 - Functioning status signal (Steady green/Flashing green)
- 3 - Led (Not used on this model)

Pump release.

If after a long period of inactivity, the circulator is blocked, adjust the screw in the centre of the head in order to manually release the motor shaft.

Take great care during this operation to avoid damage to the motor.

Bypass Adjustment (Parag.1.40).

The appliance leaves the factory with the bypass open.

If necessary, the by-pass can be regulated to system requirements from minimum (by-pass closed) to maximum (by-pass open).

Adjust using a flat head screwdriver, turn clockwise and open the by-pass, anticlockwise it is closed.



The bypass ensures minimum circulation of the water in the appliance and its correct operation if the systems are divided into more than one zone.

Total head available to the system.

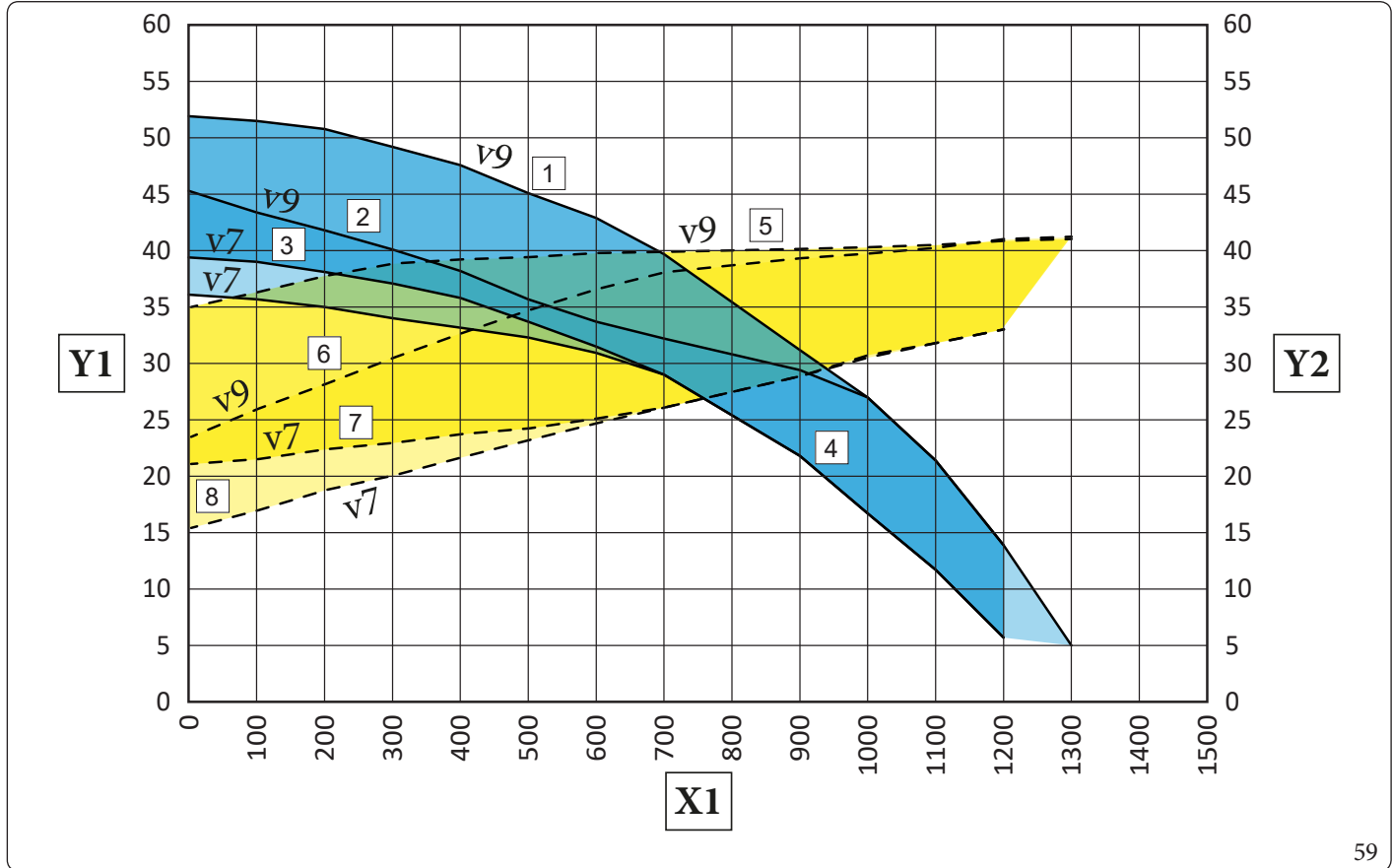

Key (Fig. 59):

X1 = Flow rate (l/h)

Y1 = Head (kPa)

Y2 = Circulator pump absorbed power (W)

Speed (Fig. 59):

v7 = Speed 7

v9 = Speed 9

1+3 = Head available with bypass closed

2+4 = Head available with bypass open

5+7 = Power absorbed by the pump with by-pass open (dotted area)

6+8 = Power absorbed by the pump with bypass closed (dotted area)

1.39 KITS AVAILABLE ON REQUEST



Check the complete list of kits available and which can be combined with the product, consult the Immergas website, the Immergas Price List or the technical-commercial documentation (catalogues and data sheets).



1.40 MAIN COMPONENTS

INSTALLER

USER

MAINTENANCE TECHNICIAN

TECHNICAL DATA

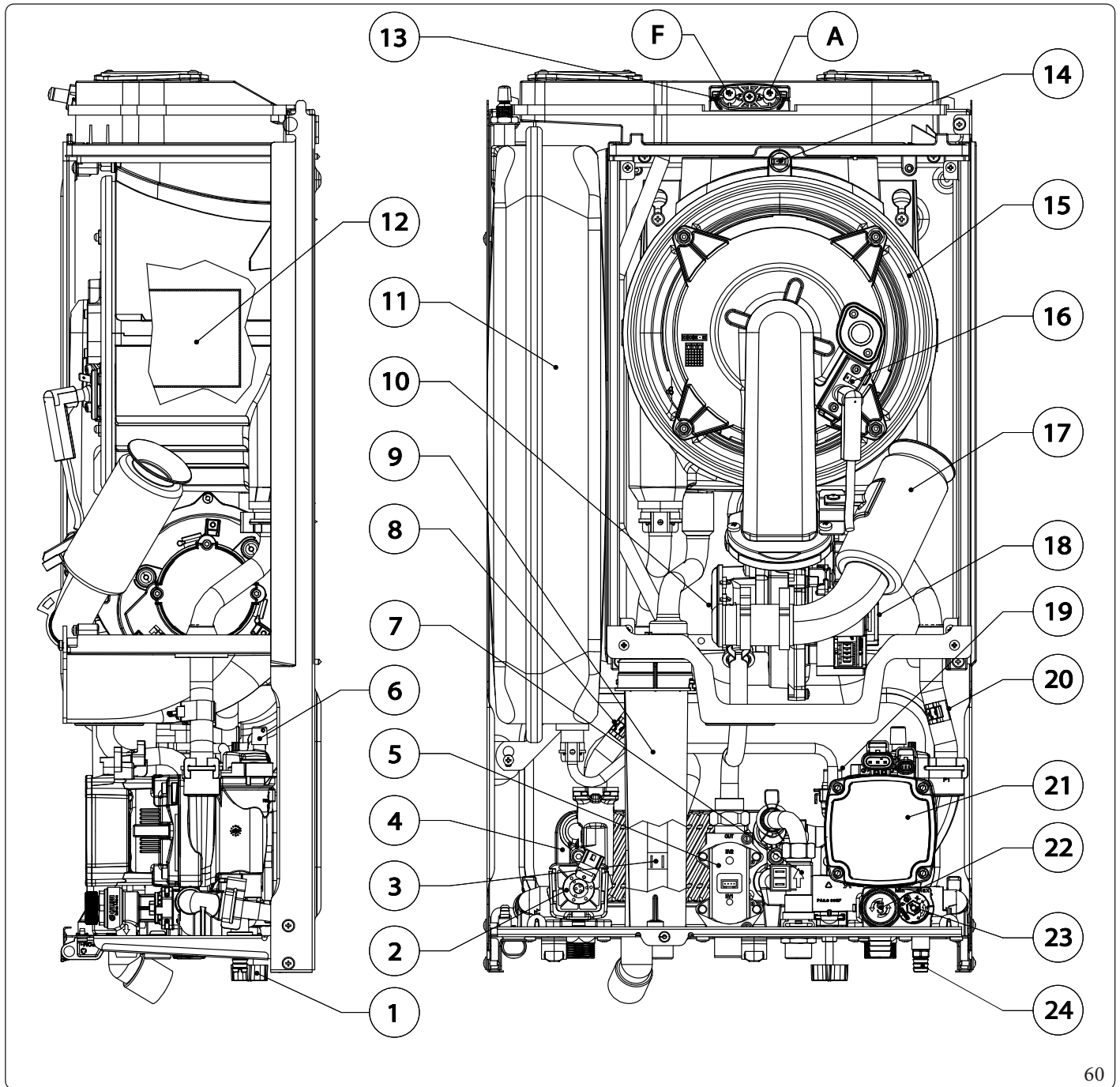

Key (Fig. 60):

- | | | | | | |
|----|---|-------------------------|----|---|--|
| 1 | - | System filling valve | 13 | - | Sample points (air A) - (flue gases F) |
| 2 | - | 3-way valve (motorised) | 14 | - | Flue probe |
| 3 | - | D.H.W. probe | 15 | - | Condensation module |
| 4 | - | D.H.W. heat exchanger | 16 | - | Ignition/detection electrode |
| 5 | - | Gas valve | 17 | - | Air intake pipe |
| 6 | - | Manual air vent valve | 18 | - | Fan |
| 7 | - | D.H.W. flow switch | 19 | - | System pressure switch |
| 8 | - | Flow probe | 20 | - | Return probe |
| 9 | - | Condensate drain trap | 21 | - | Boiler circulating pump |
| 10 | - | Air / gas mixer | 22 | - | 3 bar safety valve |
| 11 | - | System expansion vessel | 23 | - | By-pass |
| 12 | - | Burner | 24 | - | System draining valve |



2 INSTRUCTIONS FOR USE AND MAINTENANCE

2.1 GENERAL RECOMMENDATIONS

 **Never expose the wall-mounted appliance to direct vapours from a hob.**

 The device can be used by children at least 3 years old as well as by persons with reduced physical, sensory or mental capabilities, or lack of experience or required knowledge, provided that they are under surveillance, or after they have been instructed relating to the safe use and have understood the potential dangers.
Children must not play with the appliance.
Cleaning and maintenance destined to be performed by the user can not be carried out by unsupervised children.

 **For safety purposes, check that the air intake/flue exhaust terminals (if fitted) are not blocked.**

 If temporary shutdown of the appliance is required, proceed as follows:
a) drain the heating system if antifreeze is not used;
b) shut-off all electrical, water and gas supplies.

 In the case of work or maintenance to structures located in the vicinity of ducting or devices for flue extraction and relative accessories, switch off the appliance and on completion of operations ensure that a qualified technician checks efficiency of the ducting or other devices.

 **Never clean the appliance or connected parts with easily flammable substances.**

 **Never leave containers or flammable substances in the same environment as the appliance.**

 Do not open or tamper with the appliance.

 Do not take apart or tamper with the intake and exhaust pipes.

 Only use the user interface devices listed in this section of the booklet.

 **Do not climb on the appliance, do not use the appliance as a support base.**

 In the event of malfunctions, faults or incorrect operation, turn the appliance off and contact an authorised company (e.g. the Authorised Technical Assistance Centre, which has specifically trained staff and original spare parts).
Do not attempt to modify or repair the appliance alone.





The use of components involving use of electrical power requires some fundamental rules to be observed such as:

- do not touch the appliance with wet or moist parts of the body; do not touch when barefoot;
- never pull electrical cables or leave the appliance exposed to atmospheric agents (rain, sunlight, etc.);
- the appliance power cable must not be replaced by the user;
- in the event of damage to the power supply cable, switch off the appliance and contact exclusively qualified staff for replacement;
- if the appliance is not to be used for a certain period, disconnect the main appliance external switch.



Water at a temperature of more than 50 °C can cause serious burns.
Always check the water temperature before any use.



The temperatures indicated by the display have a tolerance of +/- 3°C due to environmental conditions that cannot be blamed on the appliance.



After brief periods of inactivity, visually check that the siphon is properly filled with condensate and top it up if necessary.



If you smell gas in the building:

- close the gas meter interception device or the main interception device;
- if possible, close the gas interception valve on the product;
- if possible, open doors and windows wide and create an air current;
- do not use open flames (e.g. lighters, matches);
- do not smoke;
- do not use electrical switches, plugs, door bells, telephones or intercom devices in the building;
- call an authorised company (e.g. Authorised Technical Assistance Centre).



if you smell burning or see smoke coming out of the appliance, switch it off, disconnect power, close the main gas isolation valve, open the windows and call an authorised company (e.g. Authorised Technical Assistance Centre).



At the end of its service life, the appliance must not be disposed of like normal household waste nor abandoned in the environment, but must be removed by a professionally authorised company as required by current legislation.
Contact the manufacturer for disposal instructions.

2.2 CLEANING AND MAINTENANCE



To preserve the appliance's integrity and keep the safety features, performance and reliability, which distinguish it, unchanged over time, you must execute maintenance operations on a yearly basis in compliance with what is stated in the relative point at "annual check and maintenance of the appliance", in compliance with national, regional, or local standards in force.

2.3 CONTROL PANEL

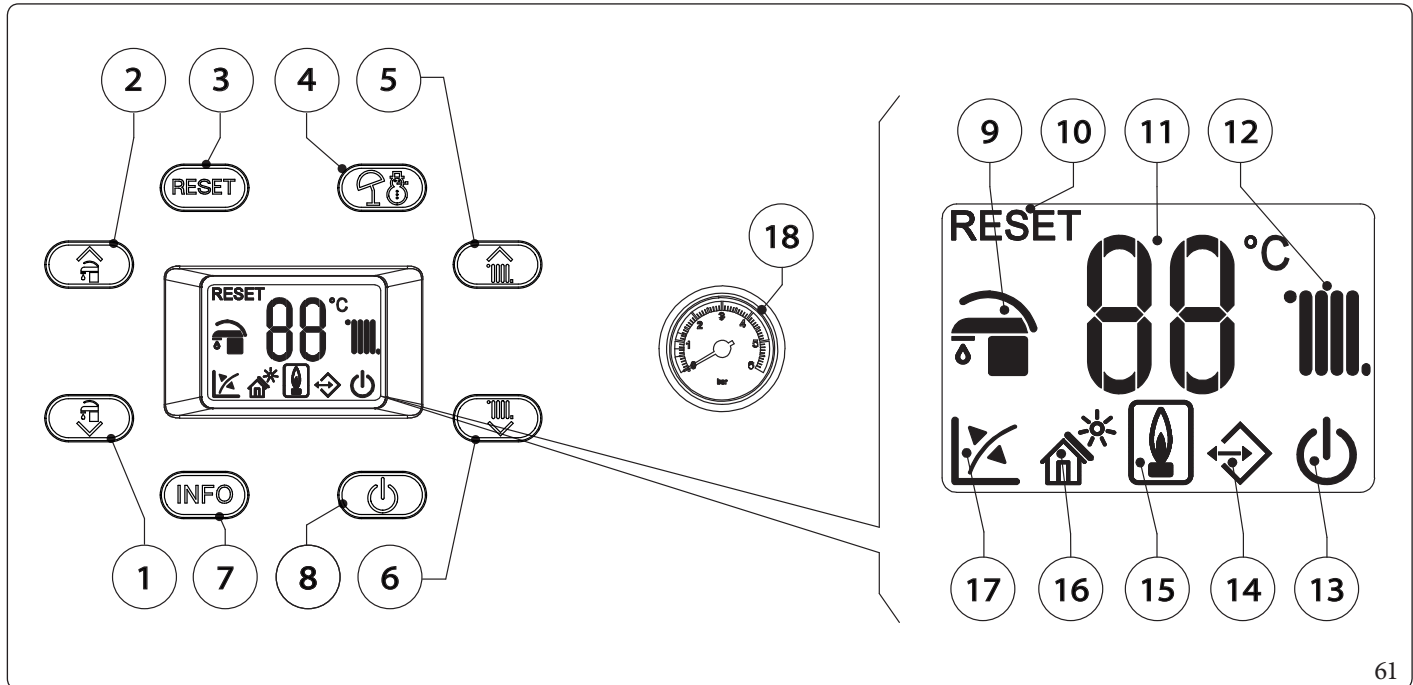

Key (Fig. 61):

- 1 - Button to reduce the domestic hot water temperature
- 2 - Button to increase the domestic hot water temperature
- 3 - Reset Button
- 4 - Summer/Winter Button
- 5 - Key to increase the system water temperature
- 6 - Key to reduce the system water temperature
- 7 - Information buttons
- 8 - Off/Stand-by/On Button
- 9 - DHW Mode in progress (flashing) / Summer mode (steady on)

- 10 - Blocked boiler, it needs to be unblocked by pressing the "RESET" button
- 11 - Temperature indicator, boiler info and error codes
- 12 - Room C.H. mode operation in progress (flashing) / Winter mode (steady on)
- 13 - Boiler in Stand-by mode
- 14 - Presence of external connected devices
- 15 - Flame presence symbol
- 16 - Solar function active
- 17 - Operation with external temperature probe active (optional)
- 18 - Boiler manometer

2.4 USING THE APPLIANCE

Boiler activation



Before ignition make sure the heating system is filled with water and that the pressure gauge (18) indicates a pressure of $1 \div 1.2$ bar.



- Open the gas isolation valve upstream from the boiler.
- If the boiler is "off", press the button until the display switches on. At this point, the boiler goes to the state previous to switch-off.
- If the boiler is on "Stand-by", press again to enable it, otherwise go to the next point.
- Then press the button and set the boiler in the summer or winter mode.



Summer 

In this mode the boiler functions only to produce the DHW, the temperature is set via the buttons  and the relative temperature is shown on the display via the indicator .



Winter 

In this mode the boiler works both for producing domestic hot water and for central heating. The temperature of the DHW is always regulated via buttons , the central heating temperature is regulated via buttons  and the relative temperature is shown on the display by the indicator . In the central heating mode, if the temperature of the water contained in the system is sufficient to heat the radiators, the boiler can only function with the activation of the pump.

From this moment the appliance functions automatically. With no demand for heat (central heating or domestic hot water production) the boiler goes to “standby” function, equivalent to the appliance being powered without presence of flame.

Each time the burner ignites, the relative flame symbol  is displayed.

Operation with Comando Amico Remoto (Remote control) v2 (CARv2)  (optional)



If the CARv2 is connected, the  symbol will appear on the display. The boiler regulation parameters can be set via the CARv2 control panel and the RESET button remains active on the boiler control panel, along with  for switch-off (“off” mode only) and the display where the functioning state is shown.



If the appliance is put into “off” mode, the “ERR>CM” connection error symbol will appear on the CARv2. The CARv2 is however powered constantly so as not to lose memorised programs.

Solar function 

This function is automatically activated if the “t3” is more than 0 seconds.

During a withdrawal, as long as the “Solar ignition delay” function is active, the boiler does not switch on; the D.H.W. withdrawal symbol  flashes on the display along with the flashing solar function symbol .

When the “Solar ignition delay” time has elapsed, the boiler switches on.

Operation with optional external probe  (optional).



In the case of a system with external probe, the boiler flow temperature for room central heating is managed by the external probe depending on the external temperature measured (Par. 1.12). The flow temperature can be modified by selecting the functioning curve via buttons  (or from the control panel of CARv2, if it is connected to the boiler), selecting a value from “0 to 9”.

With external probe present, the relative symbol  will appear on the display.

“Stand-by” Mode

Press the “Stand-by” button until the  symbol appears; from this moment the boiler remains off. The antifreeze function, pump anti-block function and three-way and signalling of any anomalies is guaranteed.

OFF mode

By holding the  button down for 8 seconds, only the frame of the symbol  remains lit on the display and the boiler is off completely. The safety functions are not guaranteed in this mode.



In “Stand-by” and “Off” mode, the appliance is to be considered still live.



2.5 FAULT AND ANOMALY SIGNALS

The boiler signals any anomalies using a code shown on the boiler display (11) according to the following table:

Error Code	Anomaly signalled	Cause	Boiler status/ Solution
01	No ignition block	In the event of request of room central heating or domestic hot water production, the boiler does not switch on within the preset time. Upon appliance commissioning or after extended downtime, it may be necessary to eliminate the block. Clogged condensate drain.	Press the Reset button (1)
02	Safety thermostat block	During normal operation, if a fault causes excessive overheating internally, the boiler goes into overheating block.	Press the Reset button (1)
03	Flue safety thermostat block	During normal operation, if a fault causes excessive flue gas overheating, the boiler blocks	Press the Reset button (1)
04	Contacts resistance block	The P.C.B. detects a fault on the gas valve supply. Check its connection. (the anomaly is detected and displayed only in the event of a request).	Press the Reset button (1)
05	Delivery probe fault	The board detects an anomaly on the flow NTC probe.	The boiler does not start (1)
06	DHW probe fault	The board detects an anomaly on the DHW NTC probe. Furthermore in this case only the antifreeze function is inhibited.	In this case the boiler continues to produce domestic hot water but not with optimal performance and with possible scalding risk(1)
08	Maximum N° of resets	Number of allowed resets already performed.	The anomaly can be reset 5 consecutive times, after which the function is inhibited for at least one hour and it is possible to try once every hour, for a maximum of 5 attempts. By switching the appliance on and off again, the 5 attempts are re-acquired
(1) If the shutdown or fault persists, contact an authorised company (e.g. Authorised Service Centre)			
(2) The anomaly can only be verified in the list of errors in the “Information” menu			

INSTALLER

USER

MAINTENANCE TECHNICIAN

TECHNICAL DATA



Error Code	Anomaly signalled	Cause	Boiler status/ Solution
10	Insufficient system pressure	Water pressure inside the central heating circuit that is sufficient to guarantee the correct operation of the boiler is not detected.	Check on the boiler pressure gauge that the system pressure is between 1-1.2 bar and restore the correct pressure if necessary (1)
16	Fan anomaly	This occurs if the fan has a mechanical or electrical fault.	Press the Reset button (1)
20	Parasite flame block	This occurs in the event of a leak on the detection circuit or anomaly in the flame control unit.	Press the Reset button (1)
23	Return probe anomaly	The board detects an anomaly on the return NTC probe.	The boiler does not start (1)
24	Push button control panel anomaly	The board detects an anomaly on the pushbutton panel.	If normal conditions are restored the boiler restarts without having to be reset (1)
27	Circulation insufficient	This occurs if there is overheating in the boiler due to insufficient water circulating in the primary circuit; the causes can be: low system circulation; check that no shut-off devices are closed on the heating circuit and that the system is free of air (deaerated); circulating pump blocked; free the circulating pump.	If normal conditions are restored the boiler restarts without having to be reset (1)
29	Flue probe anomaly	The board detects an anomaly on the flue gas probe.	The boiler does not start (1)
31	Loss of remote control communication	This occurs if an incompatible remote control is connected, or if communication between the boiler and the remote control is lost.	Disconnect and reconnect the power to the boiler. If the Remote Control is not detected on re-starting the boiler will switch to "Summer" mode. In this case the "Central Heating" (1) function cannot be activated
(1) If the shutdown or fault persists, contact an authorised company (e.g. Authorised Service Centre)			
(2) The anomaly can only be verified in the list of errors in the "Information" menu			

Error Code	Anomaly signalled	Cause	Boiler status/ Solution
36	IMG Bus communication loss	Communication between the various components is interrupted due to an anomaly on the boiler control unit, on the zone control unit or on the IMG Bus.	The boiler does not satisfy the room heating requests (1).
37	Low power supply voltage	This occurs when the power supply voltage is lower than the allowed limits for the correct boiler operation.	If normal conditions are restored the boiler restarts without having to be reset (1)
38	Loss of flame signal	This occurs when the boiler is ignited correctly and the burner flame switches off unexpectedly; a new attempt at ignition is performed and if normal conditions are restored, the boiler does not have to be reset.	If normal conditions are restored the boiler restarts without having to be reset (1)
43	Block due to loss of flame signal	This occurs if the "Flame signal loss" error occurs many times in a row within a preset period (38).	Press the Reset button, before restarting, the boiler will run a post-ventilation cycle (1)
44	Block for exceeding gas valve frequent maximum opening time	This occurs if the gas valve remains open for longer than required for normal operation, without the boiler switching on.	Press the Reset button (1)
45	ΔT high	The boiler detects a sudden, unexpected increase in the ΔT between the flow probe and the system return probe.	The power of the burner is limited to prevent damage to the condensation module and once the right ΔT is restored, the boiler resumes regular operation. Make sure there is water circulating in the boiler, that the pump is configured according to system requirements and that the return probe works properly. (1) (2)
47	Burner power limitation	Should flue high temperature be detected, the boiler reduces power supplied so as not to damage it.	(1)
(1) If the shutdown or fault persists, contact an authorised company (e.g. Authorised Service Centre)			
(2) The anomaly can only be verified in the list of errors in the "Information" menu			

INSTALLER

USER

MAINTENANCE TECHNICIAN

TECHNICAL DATA



Error Code	Anomaly signalled	Cause	Boiler status/ Solution
51	CAR Wireless communication failure	If there is no communication between the boiler and Wireless version CAR, an anomaly is signalled. From this moment, it is only possible to control the system by means of the control panel of the boiler itself.	Check operation of the Wireless CAR, check the battery charge (refer to the relative instructions booklet)
59	Main supply voltage frequency block	The board detects a main supply voltage frequency anomaly.	The boiler does not start (1)
60	Anomaly pump blocked	The pump is stopped due to one of the following causes: Impeller blocked, electrical fault.	Try to unblock the pump as described in the relative section. If normal conditions are restored the boiler restarts without having to be reset (1)
61	Air in circulator	Air is detected inside the pump; the pump cannot work.	Vent the pump and the central heating circuit. If normal conditions are restored the boiler restarts without having to be reset (1)
62	Complete calibration required	Missing calibration is detected by the P.C.B. It may occur in the event the P.C.B. is replaced or if the parameters are altered in the air / gas section, thus requiring "complete calibration".	The boiler does not start (1)
69	Damaged swing check valve recirculation alarm	The flue probe reading detects possible flue gas recirculation (installation C ₁₀) presumably caused by a damaged external swing check valve. NON-blocking fault.	(1)
70	Return/flow probe exchange	In case of an incorrect boiler wiring connection the error is detected.	The boiler does not start (1)
72	Fast calibration required	The P.C.B. detects that some parameters have been altered, thus requiring "fast calibration".	The boiler does not start (1)
76	Flow and/or return probes temperature drift	A malfunction of one or both system return and flow probes is detected.	The boiler does not start (1)
77	Combustion control fault	Out of range current is detected on the gas valve.	The boiler does not start (1)
78	Combustion control fault	High current on the gas valve is detected.	The boiler does not start (1)
(1) If the shutdown or fault persists, contact an authorised company (e.g. Authorised Service Centre)			
(2) The anomaly can only be verified in the list of errors in the "Information" menu			

Error Code	Anomaly signalled	Cause	Boiler status/ Solution
79	Combustion control fault	Reduced current on the gas valve is detected.	The boiler does not start (1)
80	Block - gas valve driver issue	This occurs in the event of malfunctions of the P.C.B. that controls the valve. Faulty valve.	Press the Reset button (1)
84	Combustion anomaly - power reduction in progress	A low supply pressure is detected on the gas line. As a result the appliance power is limited and the anomaly is reported.	If normal conditions are restored the boiler restarts without having to be reset (1) (2)
87	Block - gas valve control	A malfunction of one of the components that controls the gas valve has been detected.	The boiler does not start (1)
88	Block - gas valve control	A malfunction of one of the components that controls the gas valve has been detected.	The boiler does not start (1)
89	Combustion signal unstable	The flame is unstable due to: presence of flue gas recirculation, wind, unstable gas pressure, unstable fan speed, or due to system malfunction.	The boiler keeps working (1) (2)
90	Combustion signal beyond limit	The combustion signal is beyond the adjustment range required for an extended period of time.	The boiler keeps working (1) (2)
91	Incorrect ignition block	The board has exhausted all possible actions in order to obtain optimal ignition of the burner.	Press the Reset button (1)
92	Fan revs correction limit	The system has exhausted all possible corrections of the number of fan revs.	The boiler keeps working (1) (2)
93	Combustion signal beyond limit	The combustion signal is beyond the adjustment range required for a limited period of time.	The boiler keeps working (1) (2)
94	Combustion anomaly	A problem is detected on the combustion control, which may be due to: gas low pressure, flue gas recirculation, defective gas valve or P.C.B.	If normal conditions are restored the boiler restarts without having to be reset (1) (2)
95	Combustion signal discontinuous	The system detects a discontinuous combustion signal.	The boiler keeps working (1) (2)
96	Clogged flue	This occurs in the event an obstruction is detected in the flue system.	The boiler does not start (1) If normal conditions are restored the boiler restarts without having to be reset
98	Block - maximum no. of software errors	The maximum number of software errors possible has been reached.	Press the Reset button (1)
99	General block	A boiler anomaly has been detected.	Press the Reset button (1)
(1) If the shutdown or fault persists, contact an authorised company (e.g. Authorised Service Centre)			
(2) The anomaly can only be verified in the list of errors in the “Information” menu			





2.6 PARAMETERS AND INFORMATION MENU

By pressing the button “INFO”, the “Information menu” is activated for at least 1 second, displaying some boiler operating parameters. Press buttons   to scroll through the various parameters.

With the menu active on the indicator () the parameter via the letter “d” plus the number of the parameter that is being displayed will alternately show.

To view the parameter value, select it by pressing the button .

Press “INFO” or wait 15 minutes to go back to the previous screen or exit the menu.

Parameter ID	Description
d0.0	Not used
d0.1	Displays the combustion signal
d0.2	Displays the primary heat exchanger output instant heating flow temperature
d0.3	Displays the instant output temperature from the DHW exchanger
d0.4	Displays the values set for central heating set
d0.5	Displays the values set for DHW set
d0.6	Displays the external environment temperature (if optional external probe present) If the temperature is below zero, the value is displayed flashing.
d0.7	Not used
d0.8	Displays the system return water temperature
d0.9	Displays the list of the last five anomalies. Press the “  ” button to display the anomalies. Then press the   keys to scroll the list of anomalies.
d1.0	Anomaly list reset. Once “d1.0” is displayed, press the Reset button; deletion is confirmed via the “88” symbols flashing for two seconds.
d1.1	Not used
d1.2	Displays the pump operating speed
d1.3	Not used
d1.4	Displays the pump flow rate (lh/100)
d1.5	Displays the fan operating speed (rpm/100)
d1.6	Displays the temperature read on the flue probe
d1.7	Displays the calculated flow temperature
d1.8	At the end of the screed heater function, displays for how many hours the flow temperature remained at “Top set”
d1.9	Toggles between the safety software version and the functional software version
d2.0	Displays the flow temperature of zone two (optional)
d2.1	Displays the flow temperature of zone three (optional)
d2.2	Gas valve functioning meter *
d2.3	Ignition cycle meter *

(*) H-number_H, M-number_M, L-number_L will be displayed alternately and the corresponding number will be the succession of the three.

Example: Number_H = 12, Number_M = 34, Number_L = 56 will be displayed as 123456 (number of hours per d 2.2; number of cycles per d2.3)

2.7 APPLIANCE SWITCH-OFF

Switch the appliance off by putting it in “off” mode, disconnect the main switch outside of the appliance and close the gas isolation valve upstream of the appliance.

Never leave the appliance switched on if left unused for prolonged periods.

2.8 RESTORE CENTRAL HEATING SYSTEM PRESSURE

1. Periodically check the system water pressure (the appliance’s pressure gauge hand must indicate a cold value between 1 and 1.2 bar).
2. If the pressure falls below 1 bar (with the system cold) restore normal pressure via the valve located at the bottom of the appliance (Par. 1.7).
3. Close the valve after the operation.
4. If the pressure reaches values around 3 bar, there is a risk of tripping the safety valve (in this case, remove water from a radiator air vent valve until a pressure of 1 bar is achieved, or ask for assistance from professionally qualified personnel).
5. In the event of frequent pressure drops, contact qualified staff for assistance to eliminate the possible system leakage.

2.9 DRAINING THE SYSTEM

Emptying the system

1. Ensure that the filling valve is closed.
2. Open the draining valve (Par.1.40).
3. Open all vent valves.
4. At the end, close the draining valve.
5. Close all previously opened vent valves.



If fluid containing glycol was added to the system circuit, make sure it is recovered and disposed of in accordance with standard EN 1717.

2.10 EMPTYING THE D.H.W. CIRCUIT

To do this, always close the domestic cold water inlet upstream of the appliance.

Open any domestic hot water tap to discharge the pressure from the circuit.

2.11 ANTIFREEZE PROTECTION

The appliance has an antifreeze function that switches the burner on automatically when the temperature drops below 4°C (standard protection to minimum temperature of -5°C).

All information on antifreeze protection can be found in the Installer section at Parag. 1.5.

In order to guarantee the integrity of the appliance and the domestic hot water heating system in areas where the temperature drops below zero, we recommend protecting the central heating system using anti-freeze liquid and installing the Immergas Antifreeze Kit in the appliance.

2.12 PROLONGED INACTIVITY

In case of prolonged inactivity (e.g. second home), we recommend:

1. to switch off the power supply;
2. completely empty the CH circuit (to be avoided if glycol is present in the system) and the appliance's DHW circuit. In systems that are drained frequently, filling must be carried out with suitably treated water to eliminate hardness that can cause lime-scale.

2.13 CLEANING THE CASE

1. Use damp cloths and neutral detergent to clean the appliance casing.



Never use abrasive or powder detergents.



2.14 PERMANENT SHUTDOWN

In the event of permanent shutdown of the appliance, contact professional staff for the procedures and ensure that the electrical, water and gas supply lines are shut off and disconnected.



3 INSTRUCTIONS FOR MAINTENANCE AND INITIAL CHECK

3.1 GENERAL RECOMMENDATIONS



Operators who install and service the appliance must wear the suitable personal protective equipment (PPE) required by applicable law.
The list of possible PPE is not all-comprehensive as it is indicated and chosen by the Employer of the authorised company (installer or maintenance).



Before carrying out any maintenance work, make sure that:

- you have disconnected the power to the appliance;
- you have closed the gas isolation valve;
- you have discharged the pressure from the system and domestic hot water circuit.



Risk of material damage after using sprays and liquids to search for leaks

Leak sprays and liquids clog the reference hole P.Ref. (Fig. 64) of the gas valve, damaging it irreparably.
During installation and maintenance, do not use spray or liquids on the gas valve (electric connections side).



Supply of spare parts

The device's warranty shall be rendered null and void if unapproved or unsuitable parts are used for maintenance or repairs. These will also compromise the product's compliance, and the said product may no longer be valid and fail to meet the current regulations. In regard to the above, only use original Immergas spare parts when replacing components.



If additional documentation needs to be consulted for extraordinary maintenance, contact the Authorised After-Sales Service.

INSTALLER

USER

MAINTENANCE/TECHNICIAN

TECHNICAL DATA



3.2 INITIAL CHECK

Commissioning the appliance requires you to:

- ensure that the type of gas used corresponds to the boiler settings (the type of gas appears on the display on first electrical power supply, on the data nameplate or by checking the relative parameter "G");
- check connection to a 230V-50Hz power mains, correct L-N polarity and the earthing connection;
- make sure the central heating system is filled with water and that the boiler manometer indicates a pressure of 1÷1.2 bar;
- switch the boiler on and ensure correct ignition;
- check the proper calibration of the number of fan revolutions;
- check the CO₂ flow rate in the flue:
 - maximum
 - intermediate
 - minimum
- the values comply with the relevant tables (Par. 3.3);
- fill in and affix the installation information sticker on the appliance next to the data nameplate, with the same data as in this instruction manual (Par. 1.2) on the facsimile of the sticker;
- check activation of the safety device in the event of no gas, as well as the relative activation time;
- check activation of the main switch located upstream of the boiler;
- check that the intake and/or exhaust terminals are not blocked;
- ensure activation of all adjustment devices;
- seal the gas flow regulation devices (if the settings are changed);
- ensure production of domestic hot water;
- check the tightness of the hydraulic circuits;
- check ventilation and/or aeration of the installation room where provided.



Even if just one single safety check provides a negative result, do not commission the system.



3.3 YEARLY APPLIANCE CHECK AND MAINTENANCE



The following checks and maintenance should be performed once a year to ensure operation, safety and efficiency of the appliance over time.

- Clean the flue side of the heat exchanger.
- Clean the main burner.
- Check the correct positioning, integrity and cleanliness of the detection and ignition electrode; remove any oxide present.
- If deposits are detected in the combustion chamber they must be removed and the heat exchanger coils must be cleaned using nylon or broomcorn brushes; it is forbidden to use brushes made of metal or other materials that may damage the combustion chamber. It is also forbidden to use alkaline or acid detergents.
- Check the integrity of the insulating panels inside the combustion chamber and if damaged replace them.
- Visually check for water leaks or oxidation from/on connections and traces of condensate residues inside the sealed chamber.
- Check the contents of the condensate drain trap.
- Visually check that the siphon is properly filled with condensate and top it up if necessary.
- Check that there are no material residues in the condensate drain siphon clogging the condensate passage; also check that the entire condensate drainage circuit is clear and efficient.
- In the event of obstructions (dirt, sediment, etc.) with consequent leakage of condensate in the combustion chamber, one must replace the insulating panels.
- Check that the burner and gas manifold seal gaskets are intact and perfectly efficient, otherwise replace them. In any case the gaskets must be replaced at least every two years, regardless of their state of wear.
- Check that the burner is intact, that it has no deformations or cuts and that it is properly fixed to the combustion chamber lid; otherwise it must be replaced.
- Visually check that the water safety drain valve is not blocked.
- Check that, after discharging the system pressure and bringing it to zero (read on boiler pressure gauge), the expansion vessel pressure is at 1.0 bar.
- Check that the system static pressure (with system cold and after refilling the system by means of the filling valve) is between 1 and 1.2 bar.
- Check visually that the safety and control devices have not been tampered with and/or shorted, in particular:
 - temperature safety thermostat;
 - system pressure switch.
- Check the condition and integrity of the electrical system and in particular:
 - The power cables must be inside the cable fixings;
 - There must be no traces of blackening or burning.
- Check correct lighting and operation.
- Check the CO₂ by using the chimney sweep function at the three reference heat outputs, using the parameters in the table below. Should values out of the indicated tolerance range be detected, check the integrity of the ignition / detection electrode and, if required, change it, also changing the relative gasket. At this point, activate the “complete calibration” function.
- Check correct operation of control and adjustment devices and in particular:
 - system regulation probes intervention;
 - Domestic hot water control thermostat intervention.
- Check sealing efficiency of gas circuit and the internal system.
- Check the intervention of the device against no gas ionisation flame control. Intervention time must be less than 10 seconds.

INSTALLER

USER

MAINTENANCE TECHNICIAN

TECHNICAL DATA



Gastype	CO ₂ to Nominal Q.	CO ₂ to ignition Q.	CO ₂ to Minimum Q.
G20	9,0 (8,5 ÷ 9,5) %	9,0 (8,5 ÷ 9,5) %	9,0 (8,5 ÷ 9,5) %
G31	10,0 (9,5 ÷ 10,5) %	10,0 (9,5 ÷ 10,5) %	10,0 (9,5 ÷ 10,5) %

Gastype	O ₂ at Nominal Q.	O ₂ at Ignition Q.	O ₂ at Minimum Q.
G20	4,8 (5,7 ÷ 3,9) %	4,8 (5,7 ÷ 3,9) %	4,8 (5,7 ÷ 3,9) %



In the case of an annual inspection of the device, the max CO must be less than 700 ppm (0% O₂). If the CO value is higher, the device requires maintenance/repair.



If a Hydrogen ready installation is planned for H₂ percentages up to 20%, (referring to the gas distributed in the network according to local standards in force) all calibration of the unit must refer to the O₂ values in the table above.



In addition to yearly maintenance, one must also check the energy efficiency of the thermal system, with frequency and procedures that comply with the indications of the technical regulations in force.



In the setting at Q. Nominal and at Q. Minimum, if the O₂ values are not reached, the full Calibration procedure must be repeated. If after this operation the values are still not within the indicated ranges, no further adjustments are necessary.



3.4 HYDRAULIC DIAGRAM

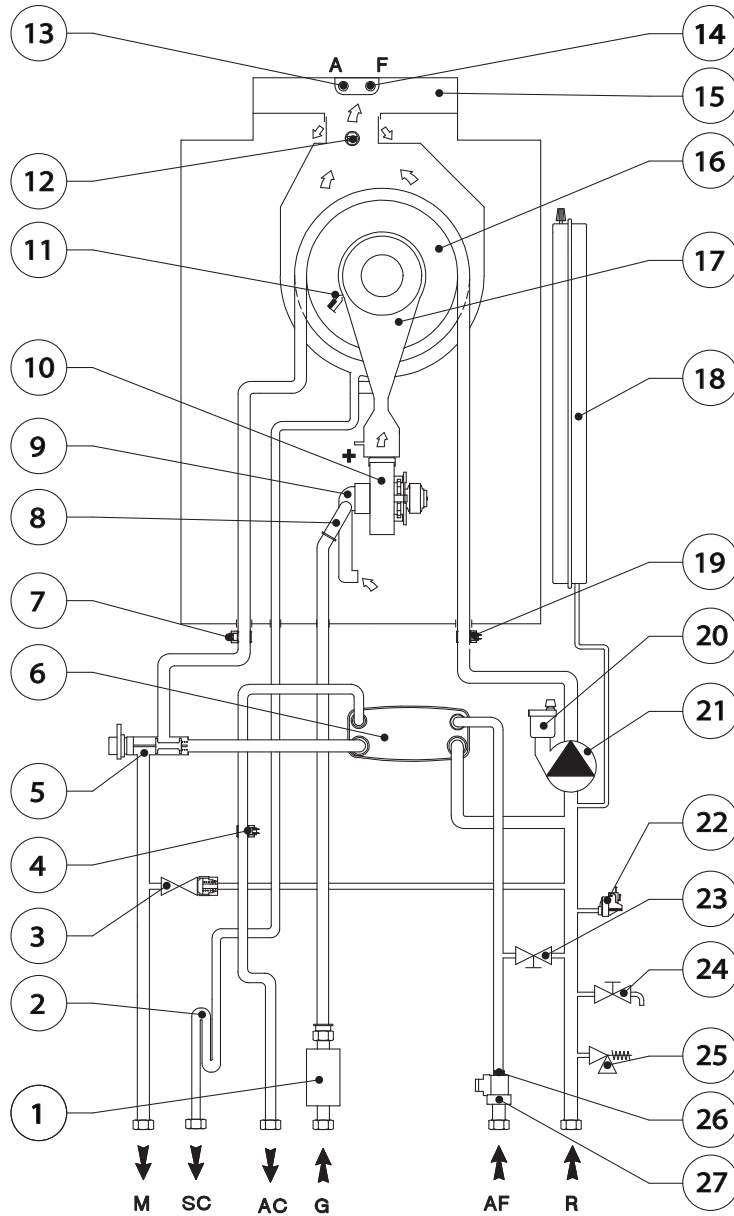

Key (Fig. 62):

- 1 - Gas valve
- 2 - Condensate drain trap
- 3 - By-pass
- 4 - D.H.W. probe
- 5 - 3-way valve (motorised)
- 6 - D.H.W. heat exchanger
- 7 - Flow probe
- 8 - Gas nozzle
- 9 - Air/gas mixer
- 10 - Fan
- 11 - Ignition/detection electrode
- 12 - Flue probe
- 13 - Air sample point
- 14 - Flue sample point
- 15 - Flue hood
- 16 - Burner
- 17 - Air/gas manifold

- 18 - System expansion vessel
- 19 - Return probe
- 20 - Air vent valve
- 21 - Boiler circulating pump
- 22 - System pressure switch
- 23 - System filling valve
- 24 - System draining valve
- 25 - 3 bar safety valve
- 26 - Flow limiter
- 27 - D.H.W. flow switch

- G - Gas supply
- AC - Domestic hot water outlet
- AF - Domestic hot water inlet
- SC - Condensate drain
- M - System flow
- R - System return

INSTALLER

USER

MAINTENANCE/TECHNICIAN

TECHNICAL DATA



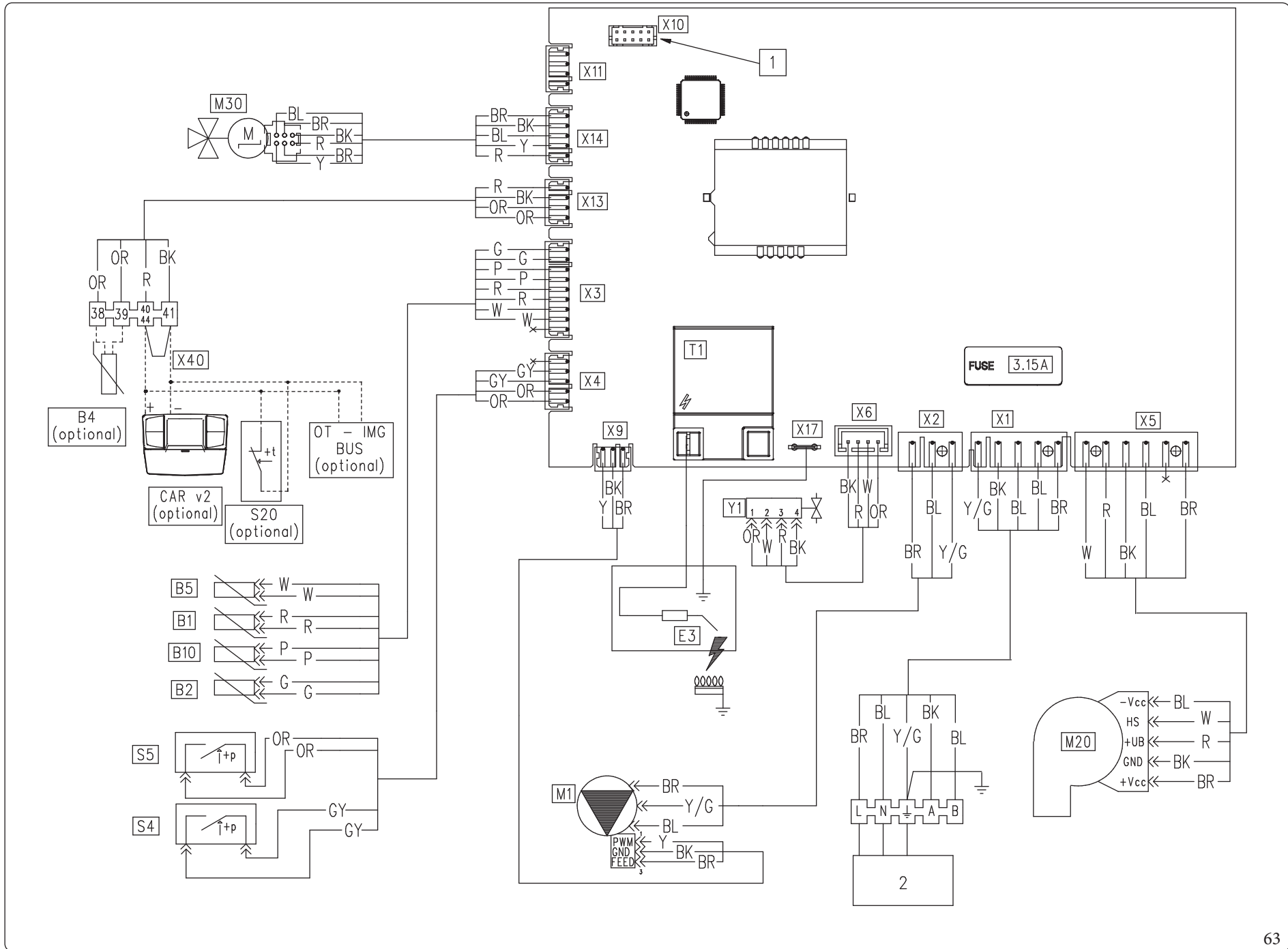

Key (Fig. 63):

- B1 - Flowprobe
- B2 - D.H.W. probe
- B4 - External probe (optional)
- B5 - Return probe
- B10 - Flue probe
- CAR^{v2} - Comando Amico Remoto^{v2} remote control (optional)
- E3 - Ignition and detection electrode
- M1 - Boiler circulating pump
- M20 - Fan
- M30 - Three-way stepper motor
- S4 - D.H.W. flow switch
- S5 - System pressure switch
- S20 - Room thermostat (optional)
- T2 - Ignition transformer
- X40 - Room thermostat link
- Y1 - Gas valve
- 1 - Virgilio palm top kit
- 2 - 230 Vac / 50 Hz power supply

Colour code key (Fig. 63):

- BK - Black
- BL - Blue
- BR - Brown
- G - Green
- GY - Grey
- OR - Orange
- P - Purple
- PK - Pink
- R - Red
- W - White
- Y - Yellow
- Y/G - Yellow/Green

Comando Amico Remoto^{v2}: the boiler is prepared for the application of the Comando Amico Remoto remote control^{v2} (CAR^{v2}), which must be connected to clamps 41 and 44/40 of the terminal board (located in the boiler control panel) respecting the polarity and eliminating link X40.

Room thermostat: the boiler is prepared for the application of the room thermostat (S20), which must be connected to clamps 44/40 - 41 of the terminal board (located in the boiler control panel) eliminating link X40.

The connector X10 is used for software updating operations.



3.6 TROUBLESHOOTING



Maintenance operations must be carried out by an authorised company (e.g. Authorised After-Sales Technical Assistance Centre).

There can be three possible causes for this anomaly:

Trouble	Possible causes	Solutions
Smell of gas	Caused by leakage from gas circuit pipelines.	Check sealing efficiency of gas intake circuit.
Repeated ignition blocks	No gas. Condensate drain clogged.	Check the presence of pressure in the network and that the gas aduction valve is open. Restore the function of the condensate drain, checking that the condensate has not affected: combustion components, fan and gas valve.
Irregular combustion or noisiness	Dirty burner, clogged primary heat exchanger, incorrect combustion parameters, intake-exhaust terminal not correctly installed.	Check the indicated components.
Non-optimal ignition of first ignitions of the burner.	The first ignitions of the burner (after calibration) may not be optimal.	The system automatically adjusts the burner ignition until the best ignition conditions are found.
Frequent trips of the overheating safety device thermostat function.	Lack of water in the appliance, little water circulation in the system or blocked pump (Par. 1.37 - 1.38).	Check on the pressure gauge that the system pressure is within established limits. Check that the radiator valves are not closed and also the functionality of the pump.
Siphon blocked	Dirt or combustion products deposited inside.	Check that there are no residues of material blocking the flow of condensate.
Heat exchanger blocked.	This may be caused by the drain trap being blocked.	Check that there are no residues of material blocking the flow of condensate.
Abnormal noises in the system	Air in the system.	Check opening of the special air vent valve cap (Par.1.40). Make sure the system pressure and expansion tank factory-set pressure values are within the set limits. The factory-set pressure values of the expansion vessel must be 1.0 bar, the value of system pressure must be between 1 and 1.2 bar.
Abnormal noises in the condensation module	Air in the module.	Use the manual air vent valve (Parag. 1.40) to remove any air inside the condensation module. When the operation has been performed, close the manual air vent valve.
Poor production of D.H.W.	Clogged condensing module or D.H.W. exchanger.	Contact After-Sales Assistance Service that has procedures to clean the module or D.H.W. heat exchanger.

Red pump LED (UPM3)

Trouble	Possible causes	Solutions
Low power supply voltage	After about 2 seconds, the LED switches from green to red and the pump stops.	Wait for the power supply voltage to rise; when the pump restarts, the LED will turn green again with a delay of about one second. Note: The flow rate decreases as the supply voltage decreases.
Rotor seized	Powering the pump with the rotor seized, after about 4 seconds the LED switches from green to red,	Carefully act on the screw in the middle of the head to manually release the crankshaft; circulation starts up immediately after the rotor is released and the LED switches from red to green after about 10 seconds.
Electrical error		Check that there is no fault on the pump (on its wiring or electronics).



3.7 CONVERTING THE APPLIANCE TO OTHER TYPES OF GAS



The gas conversion operation must be carried out by an authorised company (e.g. Authorised Technical Assistance Service).

To convert to another type of gas the following operations are required:

- Select, via programming menu "G", the type of gas by selecting "nG" for methane gas and "LG" for LPG gas (Parag. 3.13).
 - Alternatively, by accessing the appropriate sub-menu, it is possible to choose "AP" propane-air gas operation.
 - Perform complete calibration (Parag. 3.9): during which, check and, if necessary, correct the CO₂ value.
 - Upon completing the conversion, apply the sticker regarding the modified gas content onto the data nameplate in the connection box.
- These adjustments must be made with reference to the type of gas used, following that given in the table (Parag. 4.2).

Checks following conversion to another type of gas.

After having made sure that the conversion is complete and that the calibration has been successful, you must make sure that:

- there is no flame in the combustion chamber;
- the burner flame is not too high or low and that it is stable (does not detach from burner);



The pressure testers used for calibration should be perfectly closed and there should be no leaks from the gas circuit.



Maintenance operations must be carried out by an authorised company (e.g. Authorised After-Sales Technical Assistance Centre).

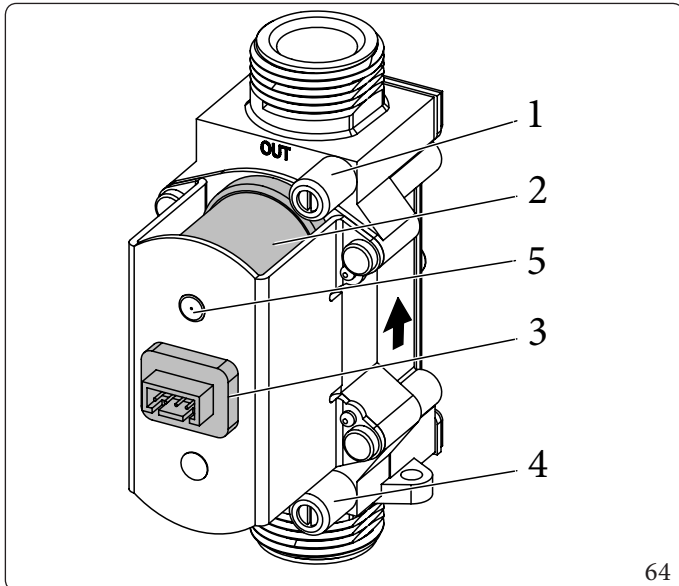

Key (Fig. 64):

- | | |
|---|-----------------------------------|
| 1 | - Gas valve outlet pressure point |
| 2 | - Coil |
| 3 | - Wiring connector |
| 4 | - Gas valve inlet pressure point |
| 5 | - P. Ref. (Reference pressure) |



3.8 CALIBRATION TYPE INVOLVING THE REPLACEMENT OF A COMPONENT.

When performing extraordinary maintenance on the boiler, involving the replacement of a component, such as the P.C.B. or components in the air, gas and flame control circuits, the boiler will need to be calibrated.

Select the type of calibration to be carried out according to the table below.

Component replaced	Type of calibration required
Gas valve	Quick calibration
Fan	Quick calibration
Burner	Complete calibration with CO ₂ check
Ignition / detection electrode	Complete calibration with CO ₂ check
P.C.B.	Restore the parameters as described in Par. 3.13 Complete calibration with CO ₂ check

3.9 COMPLETE CALIBRATION



Before carrying out complete calibration, ensure that all the requirements indicated in par.1.33 and 1.34).

To access this function it is crucial that there are no active requests for central heating or DHW production and that the boiler is not in "Stand-by" mode.

In the event of anomaly "62" or "72" (Par.2.5) the appliance cancels any requests by itself.

During the various calibration stages, the CO₂ value can be checked and possibly corrected as described in Par. 3.10.

The energy produced is dissipated via the heating circuit; alternatively, the energy can be released from the DHW circuit by opening any hot water tap.



In this case the only active temperature control is the flow probe that limits the maximum temperature exiting the boiler at 90°C, therefore be careful not to get burned.

The calibration procedure involves various stages:

- nominal heat output calibration;
- intermediate heat output ignition calibration;
- minimum heat output calibration;
- calibration self-check.

Each calibration procedure, if carried out without altering the parameters, lasts 5 minutes at the most, after which it switches automatically to the next parameter until the calibration process is complete.



Once activated, to cancel the complete calibration function, press the button (INFO) for 2 seconds or disconnect the power supply. The adjustments present before activating the function will be maintained.



Complete calibration activation

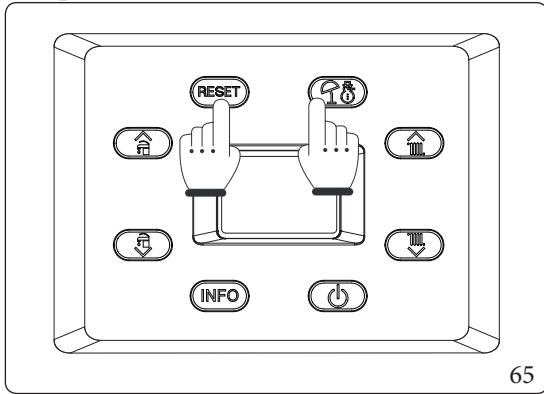

Press and hold buttons “RESET” and “1-2” for more than 5 seconds.

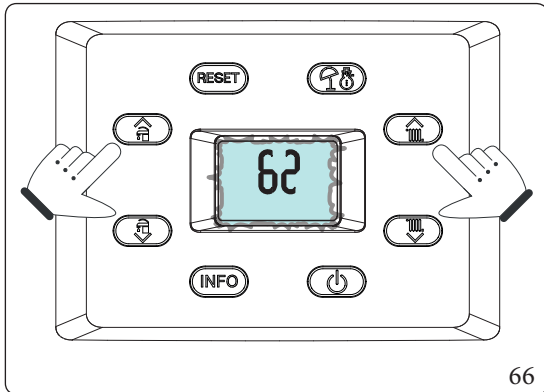

The display will show two dashes “--” flashing. Now enter the password “62” to activate the complete calibration (enter the first digit by pressing the 1-2 buttons (1 2) and the second digit by pressing the buttons 5-6 (5 6)).

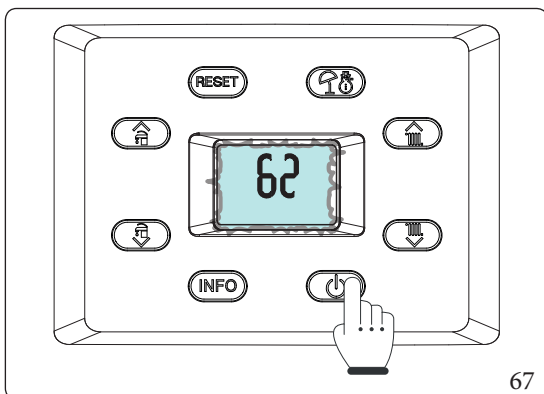

Press the “⏻” key to activate calibration.

Once activated, the complete calibration function has four phases:

Nominal heat

output: with the function active, the boiler carries out the procedures required to calibrate the appliance at the nominal heat output. At this stage the display features flashing icons: “🏠*” and “⏻” and the operating temperature alternated with the current operating heat output (99%) is displayed; once the parameters are detected and stabilised, the “🔥” symbol will start flashing (this may take a few minutes), meaning that the nominal heat output settings have been set.

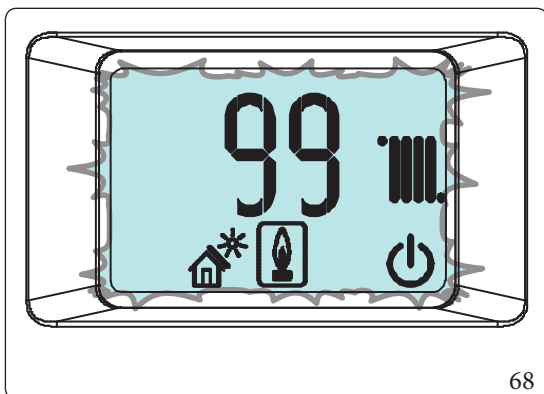



Only after the symbol “🔥” flashes is it possible to correct the CO₂ value (Parag. 3.10) or switch to the next heat input parameter by pressing the “⏻” button.





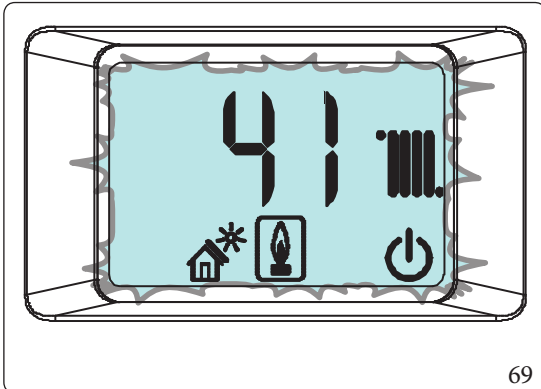

Ignition intermediate heat output

Once the nominal heat output calibration is confirmed, the appliance is calibrated with the intermediate heat output (or ignition heat output).

At this stage the display features flashing icons: “” and “” and the operating temperature alternated with the current operating heat output (e.g.: 41%) is displayed; once the parameters are detected and stabilised, the “” symbol will start flashing, meaning that the nominal heat output settings have been set.





Only after the symbol “” flashes is it possible to correct the CO₂ value (Parag. 3.10) or switch to the next heat input parameter by pressing the “” button.



Only after the symbol “” flashes is it possible to correct the CO₂ value (Parag. 3.10) or switch to the next heat input parameter by pressing the “” button.

Minimum heat output

After having calibrated the boiler with the intermediate heat output, it is calibrated with the minimum heat output.

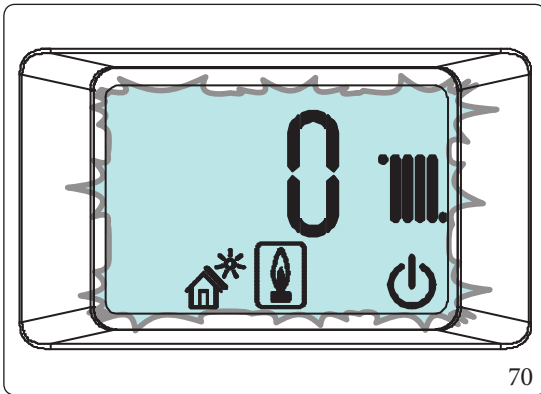
At this stage the display features flashing icons: “” and “” and the operating temperature alternated with the current operating heat output (0%) is displayed; once the parameters are detected and stabilised, the “” symbol will start flashing, meaning that the minimal heat output settings have been set.



Only after the “” symbol flashes is it possible to change the CO₂ value (Par. 3.10) or switch to the calibration self-check phase by pressing the “” button.

Calibration self-check

Once calibration operations are complete, the boiler runs a self-check for about one minute. During this check, the boiler can run at different powers and it is not possible to apply modifications to the operating parameters or to delete the operation in progress. Moreover, it is important not to cut the boiler's power.

3.10 CO₂ ADJUSTMENT

i During complete calibration (Par. 3.9) the CO₂ values can be adjusted.

To have an exact value of CO₂ in the flue, the technician must insert the sampling probe to the bottom of the sample point.



i In case of calibration for propane air, select the analyser in LPG gas mode.

Check that the CO₂ value is that indicated in the table (Par.4.2), (with maximum tolerance equal to $\pm 0.2\%$), otherwise, modify the value as described below:

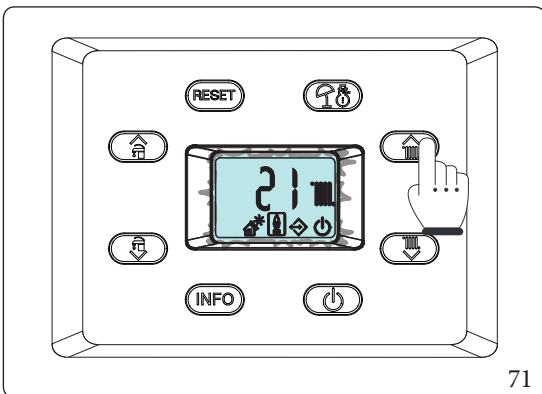

During calibration, when the “” symbol starts flashing (indicating the correct acquisition of the parameters) it is possible to alter the CO₂ value by pressing the buttons 5 or 6 ( ).

In this phase, the previously activated icons together with the “external connected devices presence icon” () will flash on the display and the operating temperature alternated with combustion setting is displayed.



To increase the combustion setting, press the button 5 () , to decrease it, press the button 6 (). As the combustion setting increases, the CO₂ value decreases and vice-versa.

Once the parameter has been altered wait for the value to be saved (displayed via the “” symbol flashing).

To confirm the value set, press “” followed by “” again in order to go to the next calibration.



3.11 QUICK CALIBRATION

This function allows you to calibrate the boiler automatically without requiring or giving the possibility to alter the parameters. Typically “fast calibration” is used after having set the type of flue in menu “F”, which once altered causes anomaly “72”.



Before performing quick calibration, ensure that all the requirements indicated in (Par.1.33 - 1.34) have been met.



No active requests for central heating or D.H.W. production must be present and the boiler must not be in “Stand-by” mode.

In the event of anomaly “72” (Par.2.5) the boiler cancels any requests by itself.

The energy produced is dissipated via the heating circuit; alternatively, the energy can be released from the DHW circuit by opening any hot water tap.



In this case the only active temperature control is the flow probe that limits the maximum temperature exiting the boiler at 90°C, therefore be careful not to get burned.

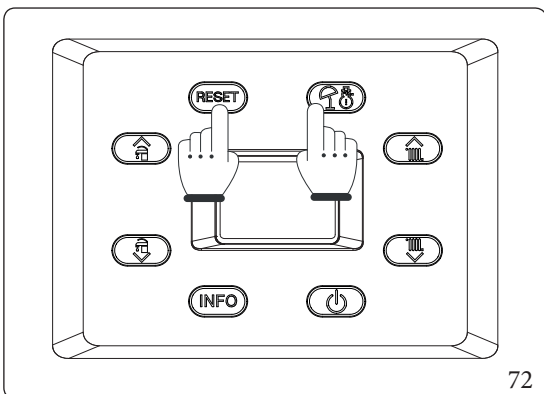

Press and hold buttons “RESET” and “flame” for more than 5 seconds.

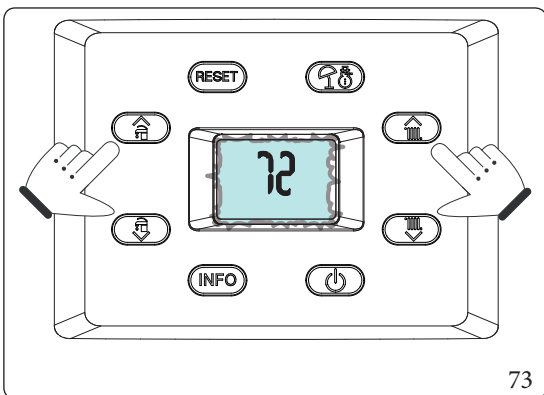

The display will show two dashes “--” flashing. Now enter the password “72” to activate fast calibration.

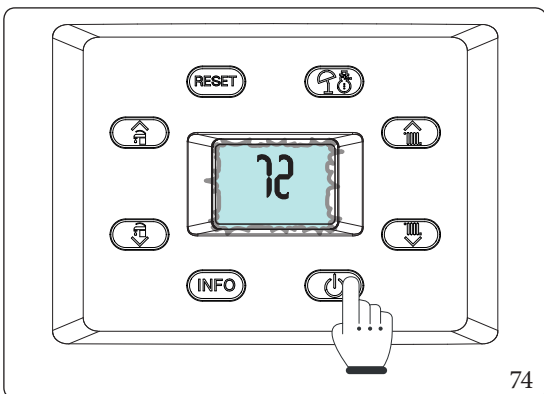

Press the “power” key to activate calibration.

Once the function is active, the appliance sequentially carries out the procedures required to calibrate the appliance with the nominal, intermediate and minimum heat output values.

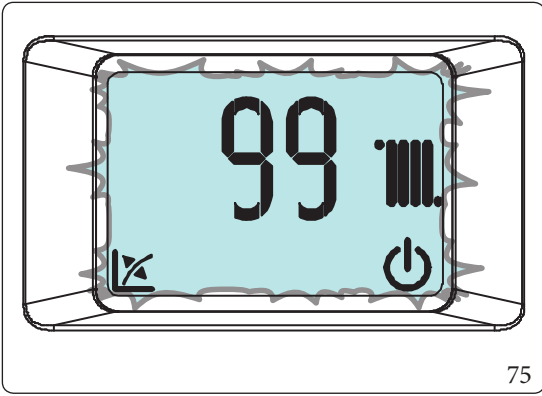

At this stage the display features flashing icons: “” and “” and the operating temperature is displayed, alternated with the current operating heat output.

The calibration stages (nominal, intermediate and minimum) progress **automatically** and you must wait until calibration is complete.

INSTALLER

USER

MAINTENANCE/TECHNICIAN

TECHNICAL DATA



3.12 FLUE TEST

To define the value to set in the "flue length" "F0" parameter, detect the parameters during the "flue test".



Before performing the test, ensure that the condensate drain trap has been filled correctly and check that there are no obstructions in the air intake circuit and flue exhaust and that the sealed chamber is perfectly closed and the flue has already been installed.

Once the test has been carried out properly, note the detected value in the relevant table, in order to have it available for future checks. To activate this mode, the boiler must be in "Stand-by" mode.



If the boiler is connected to the CAR^{v2} the "stand-by" function can only be activated via the remote control panel.

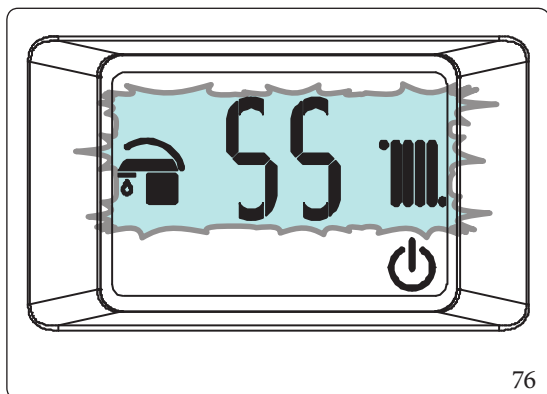

To activate the function, press the buttons "RESET" and "⏻" simultaneously until function activation, which is displayed by indicating the fan operation speed (in hundreds of revs) and ignition of the flashing "🌀" and "🔥" symbols.

The appliance remains in this mode for a maximum period of 15 minutes, keeping the fan speed constant. This function ends once 15 minutes have elapsed, or by disconnecting supply voltage to the boiler, or by pressing the "RESET" button. Check the ΔP between two pressure tests (Fig. 60) and set the parameter F0 according to the values in the table below:

VICTRIX OMNIA V2	
Parameter F0	Pressure
0	≤ 88 Pa
1	> 88 Pa
2	> 130 Pa
Value detected on first check	



This procedure must not be carried out in the case of installation C₍₁₀₎₃ - C₍₁₂₎₃. In that case, parameter F1 must be set at 1.



Examinations are carried out by sealing the holes provided to analyse the flues, making them pneumatically sealed.



Should there be a appliance malfunction, you can carry out a flue test to check that there are no obstructions in the flue system. Different values to those indicated in the previous tables indicate a flue system malfunction, especially a flue system with excessive load losses or obstructed system.



3.13 P.C.B. PROGRAMMING

The device is prepared for possible programming of several operation parameters.

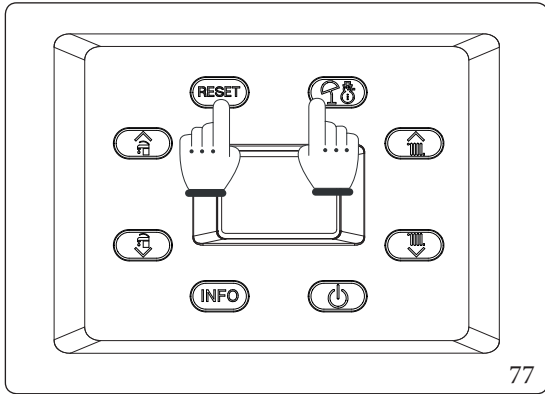

By modifying these parameters as described below, the device can be adapted according to specific needs.

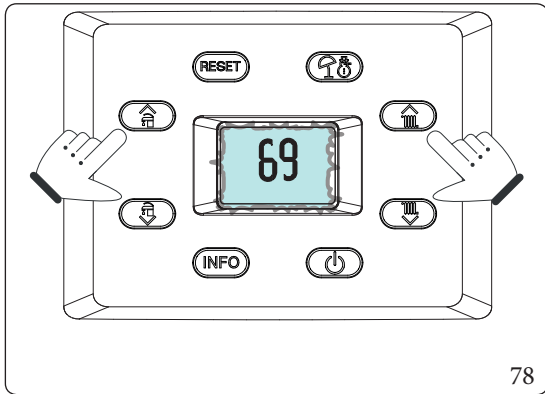

To access the programming phase, press and hold the buttons “RESET” and “” for more than 5 seconds, the display shows two dashes “--” flashing.



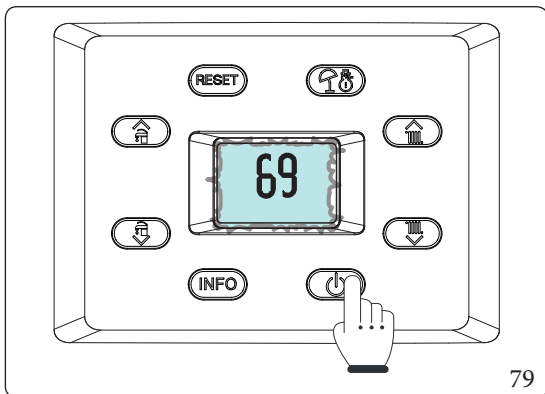

Now enter the password “69” to access the parameter menu.

To enter the first digit, use the buttons to adjust the DHW “”; to enter the second digit, use the buttons to adjust the central heating temperature “”.

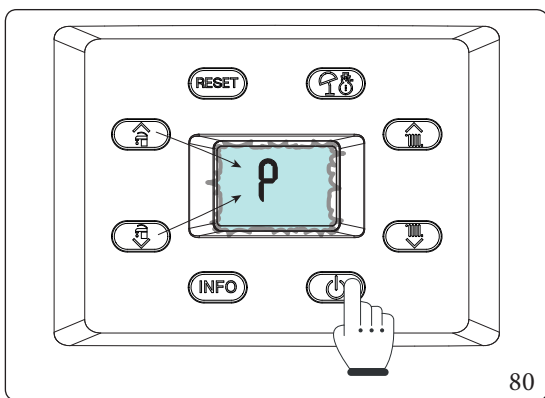

To confirm the password “69” and access the menu, press the “”.



Once in the menu, you can cyclically scroll the submenus by pressing the D.H.W. buttons “”, to access the menu press the button “”.



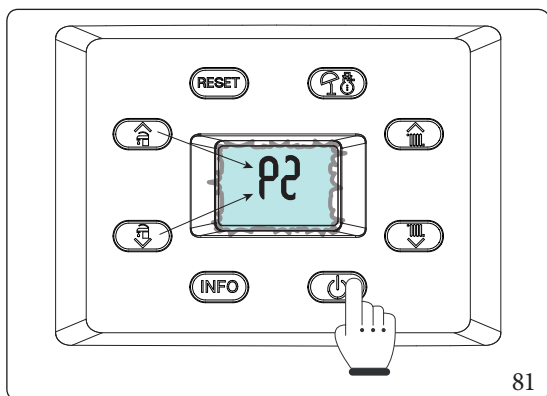

The first digit of the central indicator (P) shows the family of the parameter. The second digit shows the parameter number. Press the “⏻” button to display the value of the selected parameter.

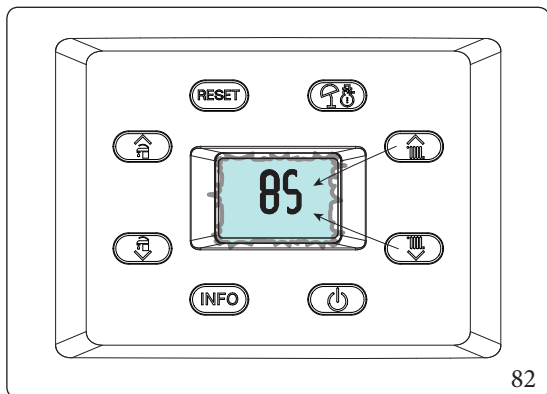

Its value can be adjusted by using the central heating temperature adjustment buttons “⬆️⬇️⬆️”.

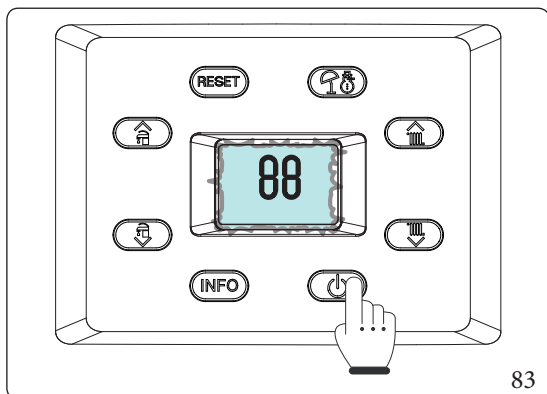

Press the mode of operation button “⏻” for more than 1 second to store the parameter value; confirmation is given by the word “88” which appears for 2 seconds. If you want to exit a parameter without changing its value, press the button “INFO”. Exit the programming mode by waiting 15 minutes or by pressing the “INFO” button until you return to the desired display.



If necessary the default values relating to parameters “S” and “P0 ÷ P2” can be altered by temporarily modifying the type of gas (parameter “G”) and by restoring it according to the actual operating conditions (wait for approximately 10 seconds between the gas change and the when it is restored).

The restored values will be those relating to the type of boiler set in parameters “n” and “F”. At the end of this operation, anomaly “E62” will appear and complete calibration will be required.

Menus “G” - “S” - “n”.

These menus are reserved for air-gas control settings. Every time these parameters are altered, the complete calibration function must be activated (Par. 3.9).



Id Parameter	Parameter	Description	Range	Default	Value customized
G	Gastype	Defines operation with methane gas	nG	nG	
		Defines operation with LPG gas	LG		
		Defines operation with propane air gas (can be activated by means of a special menu)	AP		

In the event of an alteration, an anomaly "E62" appears and complete calibration is required.

Id Parameter	Parameter	Description	Range	Default	Value customized
n	Boiler model	Define the boiler model	0 ÷ 2	2	

In the event of an alteration, an anomaly "E62" appears and complete calibration is required.

Id Parameter	Parameter	Description	Range	Default	Value customized
S0	Min output	The P.C.B. defines the operating mode and the boiler output according to the combination of several parameters. The proper operating output of the appliance is defined according to the combination of the parameters of menus "n" and "F". For this reason it is recommended not to alter the parameters of this menu in order not to compromise the proper operation of the boiler.	750 ÷ 1700 rpm	1250 rpm	
S1	Max output		S0 ÷ 6900 rpm	6125 rpm	
S2	Ignition output		2000 ÷ 4500 rpm	3200 rpm	

In the event of an alteration, an anomaly "E62" appears and complete calibration is required.

Id Parameter	Parameter	Description	Range	Default	Value customized
P0	DHW max	Defines the maximum heat output percentage of the boiler during the D.H.W. phase compared to the maximum heat output available	0 - 99 %	99 %	
P1	Min output	Defines the minimum heat output percentage of the boiler compared to the minimum heat output available	0 - P2	0 %	
P2	Central heating max	Defines the maximum heat output percentage of the boiler during the central heating mode compared to the maximum heat output available	0 - 99 %	71 %	
P3	-	Not used	-	-	
P4	-	Not used	-	-	
P5	-	Not used	-	-	
P6	Pump functioning	The pump can function in two ways. 0 intermittent: in winter "mode" the circulator is managed by the room thermostat or by the remote control. 1 continuous: in "winter" mode the circulator is always powered and is therefore always in operation	0 - 1	0	
P7	External probe correction	If the reading of the external probe is not correct it is possible to correct it in order to compensate any environmental factors.	-9 ÷ 9 K	0	

INSTALLER

USER

MAINTENANCE TECHNICIAN

TECHNICAL DATA



Id Parameter	Parameter	Description	Range	Default	Value customized
t0	Central heating setpoint minimum temperature	Defines the minimum flow temperature.	20 ÷ 50 °C	25	
t1	Central heating setpoint maximum temperature	Defines the maximum flow temperature.	(t0+5) ÷ 85 °C	85	
t2	D.H.W. thermostat	The boiler switches off on the basis of the temperature set. 0 = Fixed: the switch-off temperature is fixed at the maximum value regardless of the value set on the control panel. 1 = Correlated: the boiler switches off according to the temperature set.	0 - 1	0	
t3	Solar delay timing	The boiler is set to switch-on immediately after a request for DHW. In the case of coupling with a solar storage tank positioned upstream from the boiler, it is possible to compensate the distance between the storage tank and the boiler in order to allow the water to reach the boiler. Set the time necessary to verify that the water is hot enough (Par. 3.14 Solar panels coupling).	0 - 30 seconds	0	
t4	D.H.W. priority timing	In winter mode the boiler, at the end of a domestic hot water request, is ready to switch to central heating mode if there is an active request. Timing sets a time period in which the boiler waits before changing the operating mode, in order to quickly and comfortably satisfy an additional request for domestic hot water.	0 - 100 seconds (step 10 sec)	2	
t5	Heating activation timing	The boiler has an electronic timer, which prevents the burner from igniting too often in central heating mode.	0 - 600 seconds (step 10 sec)	18	
t6	Heating ramp timing	In central heating mode, the boiler performs an ignition ramp in order to reach the maximum output set.	0 - 840 seconds (step 10 sec)	18	
t7	CH ignition delay from TA and CR request	The boiler is set to switch-on immediately after a request. In the event of particular systems (e.g. area systems with motorised thermostatic valves etc.) it may be necessary to delay ignition.	0 - 600 seconds (step 10 sec)	0	
t8	Display lighting	0 = Automatic: the display lights up during use and goes off after 15 seconds of inactivity. In the event of an anomaly the display "flashes". 1 = Off: the display is always off. 2 = On: the display is always lit up.	0 - 2	0	

Id Parameter	Parameter	Description	Range	Default	Value customized
t9	Display	Establishes what the indicator I1 displays (Fig. 61). "Summer" mode: 0: the indicator is always off 1: active pump displays the flow temperature, pump off the indicator is off "Winter" mode: 0: always displays the value set on the C.H. selector 1: active pump displays the flow temperature, pump off always displays the value set on the C.H. selector	0 - 1	1	
t10	Flow off temperature increase	Increases the flow off temperature at ignition only in the first 60 seconds. After the flame is detected, the temperature is increased by t10	0 - 15	0	
t11		Not used on this boiler model	0 - 1	0	

INSTALLER

Id Parameter	Parameter	Description	Range	Default	Value customized
A0	Hydraulic model	Defines the type of hydraulics in the boiler	0	0	
A1	-	Not used on this boiler model	-	-	
A2	Circulating pump model	Defines the type of circulator in the boiler	0 ÷ 1	0	
A3	Maximum pump speed	Sets the maximum pump operating speed	1 ÷ 9	9	
A4	Minimum pump speed	Sets the minimum pump operating speed	1 ÷ A3	7	
A5	Circulating pump mode	Sets the pump operating mode - DELTA T = 0: proportional head - DELTA T = 5 - 25 K: ΔT constant (Parag. 1.37 - 1.38)	0 ÷ 25	15	

USER

Id Parameter	Parameter	Description	Range	Default	Value customized
F0	Flue length	Defines the length of the flue (Par. 3.12)	0 - 2	0	
F1	Presence of clapet valve on flue gas (C ₍₁₀₎₃ - C ₍₁₂₎₃)	If present, automatic corrections are made to the fan's operating range and additional controls on the flue probe.	0 - 1	0	

MAINTENANCE/TECHNICIAN

In the event of an alteration, anomaly "E72" appears and fast calibration is required.

TECHNICAL DATA



3.14 SOLAR PANELS COUPLING

The device is set up to receive pre-heated water from a system of solar panels up to a maximum temperature of 65°C. In any case, it is always necessary to install a mixing valve on the hydraulic circuit upstream of the device, on the cold water inlet.



For good functioning of the boiler; the temperature selected on the solar valve must be 5 °C greater with respect to the temperature selected on the boiler control panel.

In this condition, parameter t2 (DHW thermostat) must be set at “1” and parameter t3 (solar delay time) must be set for a period that is sufficient to receive water from a storage tank located upstream of the boiler. The greater the distance from the storage tank, the longer the stand-by time to be set.



3.15 CHIMNEY SWEEP

When activated, this function forces the boiler to variable output for 15 minutes.



In this state, all adjustments are excluded and the safety thermostat and the limit thermostat functions remain active. To activate the chimney sweep function, press the “RESET” button until activation of the function in the absence of DHW requests.

Its activation on the boiler display is confirmed by the indicators flashing at the same time ( , ), while on the CARv2 (optional) it is reported as “ERR>07”.

This function allows the technician to check the combustion parameters.

Once the function is activated, it is possible to select whether to make the check in C.H. status or D.H.W. status by opening any hot water valve adjusting the power via the buttons ( ).

The maximum power that can be supplied (99%) is relative to the power set by parameter “P2” (Par. 3.13).

The central heating or D.H.W. operating mode is displayed by the relative symbols  or .

After the checks, deactivate the function by switching the boiler off and starting it again using “  ”.



The appliance needs a certain amount of time to stabilise itself before carrying out a combustion parameters check. It is thus necessary to wait for the appliance to carry out a self-diagnosis test, which is signalled by the () flashing symbol. Once the symbol stops flashing, it is possible to check the combustion parameters.

3.16 PUMP ANTI-BLOCK

The appliance has a function that starts up the pump at least once every 24 hours for 30 seconds in order to reduce the risk of the pump locking up due to prolonged inactivity.

3.17 THREE-WAY ANTI-BLOCK

In both phase “DHW”, and “DHW-C.H.”, the appliance has a function that activates the motorised 3-way unit 24 hours after the last time it operated by running a complete cycle in order to reduce the risk of the 3-way blocking due to prolonged inactivity.

3.18 RADIATOR ANTIFREEZE

If the system return water is below 4°C, the appliance starts up until reaching 42°C.

3.19 P.C.B. PERIODICAL SELF-CHECK

During functioning in Central heating mode or with appliance in Standby, the function activates every 18 hours after the last appliance check/power supply. In case of functioning in domestic hot water mode the self-check starts within 10 minutes after the end of the withdrawing in progress, for duration of approx. 10 seconds.



During the self-check, the appliance remains off. Warnings included.



3.20 AUTOMATIC VENT

In the case of new central heating systems and in particular mode for floor systems, it is very important that deaeration is performed correctly. The function consists of the cyclic activation of the pump (100 s ON, 20 s OFF) and the 3-way valve (120 s D.H.W., 120 s C.H.). The function is activated by pressing buttons “INFO” + “

If the boiler is connected to the CARv2 the “stand-by” function can only be activated via the remote control panel.

The function lasts for 18 hours and it can be stopped by simply pressing the button “RESET”.

Activation of the function is signalled by the countdown shown on the indicator (

3.21 SCREED HEATER

The appliance is equipped with a function to perform the thermal shock on new radiant panel systems, as required by the applicable standard.



Contact the manufacturer of the radiant panels for the thermal shock characteristics and its correct execution.



To be able to activate the function there must be no remote control connected, while in case of system divided into zones it must be properly connected, both hydraulically and electrically.

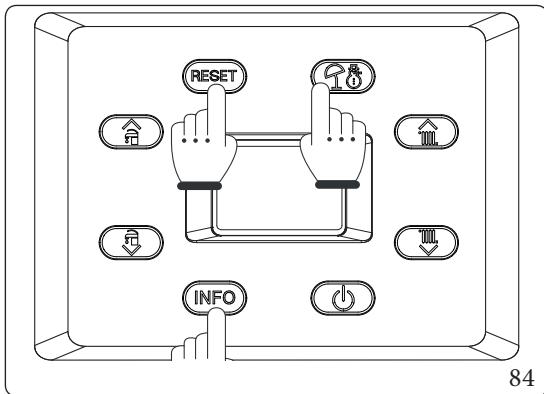

The function is activated from boiler in “off” by pressing and holding the “RESET”, “INFO” and “

The function lasts in total 7 days, 3 days at the lower temperature set and 4 days at the higher temperature set (Fig. 84).

After activating the function, the lower set (range 20 ÷ 45°C default = 25°C) and the higher set (range 25 ÷ 55°C default = 45°C) appear in sequence.

The temperature is selected by means of the buttons “ 

The display now shows the countdown of days alternated with the current flow temperature, as well as the normal operating symbols of the boiler.

In case of failure or lack of supply voltage, the function is suspended and will resume when the normal operating conditions are reset from the point where it was interrupted.

When the time expires, the boiler automatically goes back to “Stand-by” mode, the function can also be stopped by pressing the button “RESET”.



3.22 CASING REMOVAL

To facilitate appliance maintenance the casing can be completely removed as follows:

Lower grid (Fig. 85)

- Loosen the two screws under the front panel (b).
- Remove the grid (c).

Casing and control panel (Fig. 85 - 86 - 87)

- Loosen the two side screws (a).
- Remove the covering caps (d).
- Then unscrew the two fixing screws on the control panel (e).
- Pull the casing (f) towards you and release it from its lower seat.
- Loosen the screw (g) that secures the control panel.

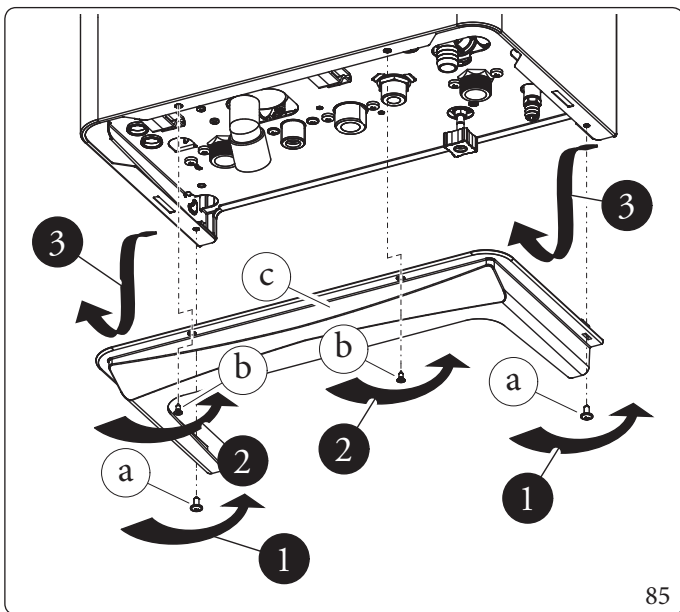

85

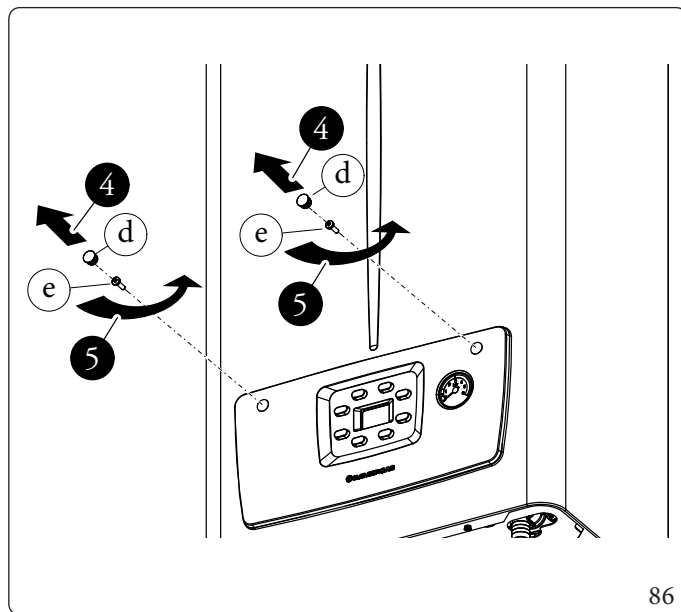

86

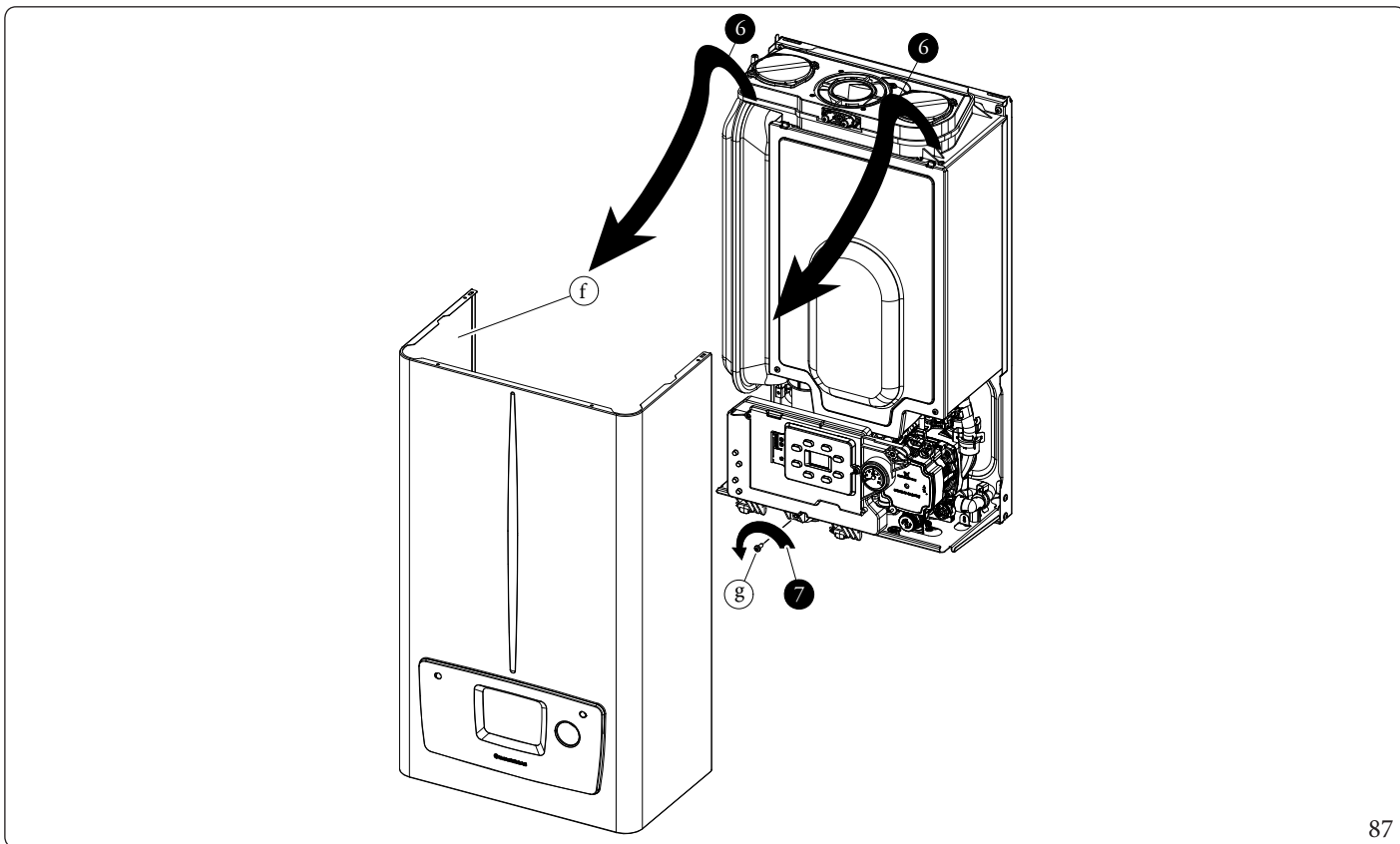

87

4 TECHNICAL DATA

4.1 VARIABLE HEAT OUTPUT



The power data in the table has been obtained with intake-exhaust pipe measuring 0.5 m in length. Gas flow rates refer to net calorific value below a temperature of 15°C and at a pressure of 1013 mbar.

FLOWRATE OUTPUT	HEAT OUTPUT		METHANE (G20)			PROPANE (G31)		
			FANREVS		GASFLOW RATE BURNER	FANREVS		GASFLOW RATE BURNER
			(rpm)	(%)	(m³/h)	(rpm)	(%)	(kg/h)
(kW)	(kW)							
26,8	26,0	D.H.W.	6125	100	2,84	6000	100	2,08
20,5	20,0	HEAT. + D.H.W.	4700	71	2,17	4650	72	1,59
19,5	19,0		4500	67	2,06	4450	68	1,51
18,5	18,0		4275	62	1,96	4225	63	1,44
17,5	17,1		4075	58	1,85	4025	59	1,36
16,5	16,1		3850	54	1,75	3825	55	1,28
15,5	15,1		3650	49	1,64	3625	50	1,20
14,5	14,1		3450	45	1,53	3400	46	1,13
13,5	13,2		3225	41	1,43	3200	41	1,05
12,3	12,0		2975	36	1,30	2950	36	0,96
11,5	11,2		2800	32	1,22	2775	32	0,89
10,5	10,2		2600	28	1,11	2575	28	0,82
9,0	8,7		2275	21	0,95	2275	22	0,70
8,0	7,7		2075	17	0,85	2050	17	0,62
7,0	6,7		1850	12	0,74	1850	13	0,54
6,0	5,7		1650	8	0,63	1650	9	0,47
5,0	4,7		1450	4	0,53	1425	4	0,39
4,1	3,9		1250	0	0,43	1250	0	0,32

INSTALLER

USER

MAINTENANCE TECHNICIAN

TECHNICAL DATA



4.2 COMBUSTION PARAMETERS

Combustion parameters: measuring conditions of useful efficiency (flow temperature/return temperature= 80/60 °C), ambient temperature reference = 20 °C.



When using H2NG mixtures with H₂ percentages up to 20% (referring to the gas distributed in the network), all calibration operations of the device must refer to the O₂ values of the gas G20 given in the following tables.

Gas type		G20	G31
Supply pressure	mbar	20,0	37,0
Gas nozzle diameter	mm	5,00	5,00
Ignition fan speed	rpm	3200	3200
Post ventilation fan speed	rpm	3200	3200
Flue flow rate at D.H.W. nominal heat output	kg/h	44	45
Flue flow rate at heating nominal heat output	kg/h	34	35
Flue flow rate at min heat output	kg/h	7	7
CO ₂ at Nominal Q.	%	9,0 (8,5 ÷ 9,5)	10,0 (9,5 ÷ 10,5)
*O ₂ at Nominal Q.	%	4,8 (5,7 ÷ 3,9)	- (- ÷ -)
CO ₂ at Ignition Q.	%	9,0 (8,5 ÷ 9,5)	10,0 (9,5 ÷ 10,5)
*O ₂ at Ignition Q.	%	4,8 (5,7 ÷ 3,9)	5,6 (6,4 ÷ 4,9)
CO ₂ at Minimum Q.	%	9,0 (8,5 ÷ 9,5)	10,0 (9,5 ÷ 10,5)
*O ₂ at Minimum Q.	%	4,8 (5,7 ÷ 3,9)	- (- ÷ -)
CO with 0% O ₂ at Nom./Min. Q.	ppm	200 / 12	245 / 16
NO _x with 0% O ₂ at Nom./Min. Q.	mg/kWh	30 / 25	34 / 29
Flue temperature at nominal output	°C	75	75
Flue temperature at minimum output	°C	62	62
Max air combustion temperature	°C	50	50
Maximum flue gas circuit temperature	°C	120	120

4.3 TECHNICAL DATA TABLE

		VICTRIX OMNIA V2	
Domestic hot water nominal heat input	kW	26,8	
Central heating nominal heat input	kW	20,5	
Minimum heat input	kW	4,1	
DHW nominal heat input with 20% H ₂ NG gas	kW	25,5	
Po Central heating nominal heat input with 20% H ₂ NG gas	kW	18,4	
Minimum heat input with 20% H ₂ NG gas	kW	4,1	
Domestic hot water nominal heat output (useful)	kW	26,0	
Central heating nominal heat output (useful)	kW	20,0	
Minimum heat output (useful)	kW	3,9	
*Effective thermal efficiency 80/60 Nom./Min.	%	97,4 / 94,5	
*Effective thermal efficiency 50/30 Nom./Min.	%	105,2 / 105,8	
*Effective thermal efficiency 40/30 Nom./Min.	%	107,1 / 108,6	
Efficiency at 100% heat output (η_{100}) ref. UNI EN 15502-1	%	97,5	
Efficiency at partial heat load (η_{30}) ref. UNI EN 15502-1	%	109,7	
Casing losses with burner On/Off	%	0,44 / 0,22	
Chimney losses with burner Off/On	%	0,00 / 2,38	
Maximum heating temperature	°C	90	
Adjustable central heating temperature (min. operating field)	°C	20	
Adjustable central heating temperature (max operating field)	°C	85	
System expansion vessel total volume	l	5,8	
Expansion vessel pre-charged pressure	bar	1,0	
Appliance water content	l	2,5	
Domestic hot water adjustable temperature	°C	20 / 60	
Central heating circuit max. operating pressure	bar	3,0	
Domestic hot water circuit min. pressure (dynamic)	bar	0,3	
Domestic hot water circuit max. operating pressure	bar	10,0	
Flow rate capacity in continuous duty (ΔT 30°C)	l/min	12,4	
Weight of full boiler	kg	33,4	
Weight of empty boiler	kg	27,5	
Electrical connection	V/Hz	230 / 50	
Installed electric power	W	90	
Equipment electrical system protection	IP	X5D	
Ambient operating temperature range	°C	-5 ÷ 40	
Ambient operating temperature range with antifreeze kit (optional)	°C	-15 ÷ 40	
NO _x class	-	6	
*Weighted NO _x G20	mg/kWh	31	
Weighted CO G20	mg/kWh	25	
Weighted NO _x G31	mg/kWh	-	
Weighted CO G31	mg/kWh	-	
Type of appliance	-	B ₂₃ B _{23p} B ₃₃ B ₅₃ B _{53p} C ₁₃ C ₃₃ C ₄₃ C ₅₃ C ₆₃ C ₈₃ C ₉₃ C _{13X} C _{33X} C _{43X} C _{53X} C _{63X} C _{83X} C _{93X} C ₍₁₀₎₃ C ₍₁₂₎₃ C _{(10)3X} C _{(12)3X} C ₍₁₅₎₃ C _{(15)3X}	
Market		IE	EE
Category		-	-

* Efficiencies and weighted NO_x refer to the net calorific value.

The data relevant to domestic hot water performance refer to a dynamic inlet pressure of 2 bar and an inlet temperature of 15°C; the values are measured directly at the appliance outlet considering that to obtain the data declared mixing with cold water is necessary.

The appliance is suitable for operation in a C₍₁₀₎₃ or C₍₁₂₎₃ system only with the supply of methane gas (2H and 2E categories).

Configurations C₍₁₀₎₃ and C₍₁₂₎₃ are only permitted with original, approved flue system

INSTALLER

USER

MAINTENANCE TECHNICIAN

TECHNICAL DATA



4.4 TECHNICAL PARAMETERS FOR COMBINATION BOILERS (IN COMPLIANCE WITH REGULATION 813/2013)

The efficiencies and NO_x values in the following tables refer to the gross calorific value.

Model	VICTRIX OMNIA V2		
Condensing Boiler	YES		
Low temperature boiler	NO		
Boiler type B1	NO		
Co-generation appliance for central heating	NO		
Mixed heating appliance	YES		
Nominal heat output	P _n	20	kW
Seasonal energy efficiency of central heating	η _s	94	%
For central heating only and combination boilers: useful heat output			
At nominal heat output in high temperature mode (*)	P ₄	20,0	kW
At 30% of nominal heat output in a low temperature mode (**)	P ₁	6,7	kW
For central heating only and combination boilers: useful efficiency			
At nominal heat output in high temperature mode (*)	η ₄	87,8	%
At 30% of nominal heat output in a low temperature mode (**)	η ₁	98,8	%
Auxiliary electricity consumption			
At full load	e _{l_max}	0,019	kW
At partial load	e _{l_min}	0,011	kW
In standby mode	P _{SB}	0,004	kW
Other items			
Heat loss in standby	P _{stby}	0,055	kW
Ignition burner energy consumption	P _{ign}	0,000	kW
Emissions of nitrogen oxides	NO _x	27	mg\kWh
For mixed central heating appliances			
Stated load profile	XL		
Domestic hot water production efficiency	η _{WH}	86	%
Daily electrical power consumption	Q _{elec}	0,157	kWh
Annual electrical power consumption	AEC	35	kWh
Daily gas consumption	Q _{fuel}	22,701	kWh
Annual gas consumption	AFC	18	GJ
(*) High temperature mode means 60°C on return and 80°C on flow.			
(**) Low temperature mode for condensation Boilers means 30°C, for low temperature boilers 37°C and for other appliances 50°C of return temperature.			

4.5 PRODUCT FICHE (IN COMPLIANCE WITH REGULATION 811/2013)

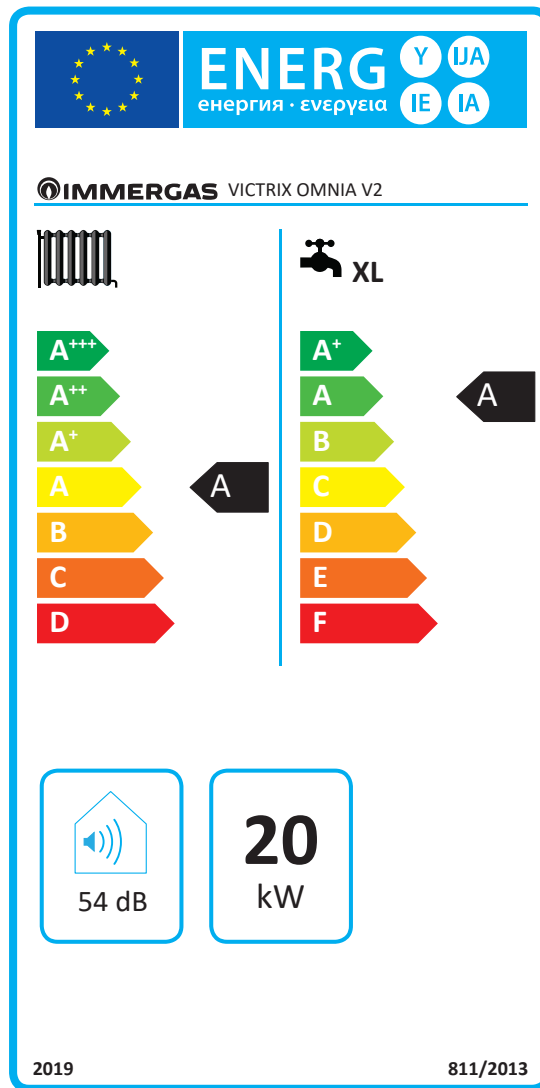

INSTALLER

USER

MAINTENANCE TECHNICIAN

88

Parameter		Value
Annual energy consumption for the central heating mode (QHE)	GJ	37
Annual electricity consumption for the domestic hot water function (AEC)	kWh	35
Annual fuel consumption for the domestic hot water function (AFC)	GJ	18
Seasonal space heating energy efficiency (η_s)	%	94
Water heating energy efficiency (η_{wh})	%	86

For proper installation of the appliance refer to chapter 1 of this booklet (for the installer) and current installation regulations. For proper maintenance refer to chapter 3 of this booklet (for the maintenance technician) and adhere to the frequencies and methods set out herein.

TECHNICAL DATA



4.6 PARAMETERS FOR FILLING IN THE PACKAGE FICHE

If an assembly is to be made from this device, use the assembly sheets shown in (Fig. 90 and 92).

For the correct compilation, insert into the appropriate spaces (as shown in the facsimile package fiche (Fig. 89 and 91) the values set out in the tables "Parameters for compiling package fiche" and "Parameters for compiling DHW pack package fiche".

The remaining values must be obtained from the technical data sheets of the products used to make up the assembly (e.g. solar devices, integration heat pumps, temperature controllers).

Use sheet (Fig. 90) for "assemblies" related to the heating function (e.g.: boiler + temperature controller).

Use sheet (Fig. 92) for "assemblies" related to the domestic hot water function (e.g.: boiler + solar thermal system).

Facsimile for filling in the package fiche for room central heating systems.

Seasonal central heating energy efficiency of the boiler 1 %

Temperature control 2

From temperature control board + %

Class I = 1 %, Class II = 2 %,
 Class III = 1.5 %, Class IV = 2 %,
 Class V = 3 %, Class VI = 4 %,
 Class VII = 3.5 %, Class VIII = 5 %

Supplementary boiler 3

From boiler board %

Seasonal central heating energy efficiency of the room (%)

$$(\text{ } - \text{'I'}) \times 0.1 = \pm \text{ } \%$$

Solar contribution 4

From the board of the solar device %

Dimensions of the manifold (in m²)

Volume of the tank (in m³)

Efficiency of the manifold (in %)

Classification of the tank
A* = 0.95, A = 0.91,
B = 0.86, C = 0.83,
D-G = 0.81

$$(\text{'III'} \times \text{ } + \text{'IV'} \times \text{ }) \times (0.9 \times (\text{ } / 100)) \times \text{ } = + \text{ } \%$$

Supplementary heat pump 5

From the heat pump board %

Seasonal central heating energy efficiency of the room (%)

$$(\text{ } - \text{'I'}) \times \text{'II'} = + \text{ } \%$$

Solar contribution and supplementary heat pump

Select the lowest value 6

$$0.5 \times \text{ } \text{ O } 0.5 \times \text{ } = - \text{ } \%$$

Seasonal central heating energy efficiency of the set 7

Seasonal central heating energy efficiency class of the set

☐	☐	☐	☐	☐	☐	☐	☐	☐	☐
G	F	E	D	C	B	A	A⁺	A⁺⁺	A⁺⁺⁺
< 30 %	≥ 30 %	≥ 34 %	≥ 36 %	≥ 75 %	≥ 82 %	≥ 90 %	≥ 98 %	≥ 125 %	≥ 150 %

Boiler and supplementary heat pump installed with low temperature heat emitters at 35 °C?

From the board of the heat pump 7 + (50 x 'II') = %

The energy efficiency of the set of products indicated in this sheet may not reflect the actual energy efficiency after installation since such efficiency is affected by additional factors, such as the heat loss in the distribution system and the size of the products compared to the size and features of the building.



Parameters for filling in the assembly chart

Parameter	VICTRIX OMNIA V2
"I"	94
"II"	*
"III"	1,34
"IV"	0,52

* to be established by means of table 5 of Regulation 811/2013 in case of "assembly" including a heat pump to integrate the boiler. In this case the boiler must be considered as the main appliance of the assembly.

Room central heating system package fiche.

1 %

Seasonal central heating energy efficiency of the boiler

Temperature control
From temperature control board

Class I = 1 %, Class II = 2 %,
Class III = 1.5 %, Class IV = 2 %,
Class V = 3 %, Class VI = 4 %,
Class VII = 3.5 %, Class VIII = 5 %

+

2 %

Supplementary boiler
From boiler board

Seasonal central heating energy efficiency of the room (%)

$(\text{ } - \text{ }) \times 0.1 = \pm \text{ } \%$

3 %

Solar contribution
From the board of the solar device

Dimensions of the manifold (in m²)

Volume of the tank (in m³)

Efficiency of the manifold (in %)

Classification of the tank
A* = 0.95, A = 0.91,
B = 0.86, C = 0.83,
D-G = 0.81

$(\text{ } \times \text{ } + \text{ } \times \text{ }) \times (0.9 \times (\text{ } / 100) \times \text{ } = + \text{ } \%$

4 %

Supplementary heat pump
From the heat pump board

Seasonal central heating energy efficiency (in %)

$(\text{ } - \text{ }) \times \text{ } = + \text{ } \%$

5 %

Solar contribution and supplementary heat pump

Select the lowest value

$0.5 \times \text{ } \text{ O } 0.5 \times \text{ } = - \text{ } \%$

6 %

7 %

Seasonal central heating energy efficiency of the set

Seasonal central heating energy efficiency class of the set

G	F	E	D	C	B	A	A ⁺	A ⁺⁺	A ⁺⁺⁺
< 30 %	≥ 30 %	≥ 34 %	≥ 36 %	≥ 75 %	≥ 82 %	≥ 90 %	≥ 98 %	≥ 125 %	≥ 150 %

Boiler and supplementary heat pump installed with low temperature heat emitters at 35 °C?
From the board of the heat pump

$\text{ } + (50 \times \text{ }) = \text{ } \%$

7 %

The energy efficiency of the set of products indicated in this sheet may not reflect the actual energy efficiency after installation since such efficiency is affected by additional factors, such as the heat loss in the distribution system and the size of the products compared to the size and features of the building.

INSTALLER

USER

MAINTENANCE TECHNICIAN

TECHNICAL DATA



Facsimile for filling in the domestic hot water production system package fiche

Water heating energy efficiency of combination boiler

¹ %

Stated load profile:

Solar contribution

From the board of the solar device

Auxiliary electricity

$$(1.1 \times \text{'I'} - 10\%) \times \text{'II'} - \text{'III'} - \text{'I'} = + \text{$$

Water heating energy efficiency of the assembly in average climate conditions

³

Water heating energy efficiency class of the assembly in average climate conditions

	<input type="checkbox"/>	<input type="checkbox"/>	<input type="checkbox"/>	<input type="checkbox"/>	<input type="checkbox"/>	<input type="checkbox"/>	<input type="checkbox"/>	<input type="checkbox"/>	<input type="checkbox"/>	<input type="checkbox"/>
	G	F	E	D	C	B	A	A ⁺	A ⁺⁺	A ⁺⁺⁺
<input type="checkbox"/> M	< 27 %	≥ 27 %	≥ 30 %	≥ 33 %	≥ 36 %	≥ 39 %	≥ 65 %	≥ 100 %	≥ 130 %	≥ 163 %
<input type="checkbox"/> L	< 27 %	≥ 27 %	≥ 30 %	≥ 34 %	≥ 37 %	≥ 50 %	≥ 75 %	≥ 115 %	≥ 150 %	≥ 188 %
<input type="checkbox"/> XL	< 27 %	≥ 27 %	≥ 30 %	≥ 35 %	≥ 38 %	≥ 55 %	≥ 80 %	≥ 123 %	≥ 160 %	≥ 200 %
<input type="checkbox"/> XXL	< 28 %	≥ 28 %	≥ 32 %	≥ 36 %	≥ 40 %	≥ 60 %	≥ 85 %	≥ 131 %	≥ 170 %	≥ 213 %

Water heating energy efficiency class in colder and hotter climate conditions

Colder: ³ 2

Hotter: ³ 2

The energy efficiency of the set of products indicated in this sheet may not reflect the actual energy efficiency after installation since such efficiency is affected by additional factors, such as the heat loss in the distribution system and the size of the products compared to the size and features of the building.



Parameters for filling in the DHW package fiche

Parameter	VICTRIX OMNIA V2
"I"	86
"II"	*
"III"	*

* to be determined according to Regulation 811/2013 and transient calculation methods as per Notice of the European Community no. 207/2014.

Domestic hot water production system package fiche.

Water heating energy efficiency of combination boiler

%

Stated load profile:

Solar contribution

From the board of the solar device

Auxiliary electricity

(1.1 x - 10 %) x - - = + %

Water heating energy efficiency of the assembly in average climate conditions

%

Water heating energy efficiency class of the assembly in average climate conditions

	<input type="checkbox"/>	<input type="checkbox"/>	<input type="checkbox"/>	<input type="checkbox"/>	<input type="checkbox"/>	<input type="checkbox"/>	<input type="checkbox"/>	<input type="checkbox"/>	<input type="checkbox"/>	<input type="checkbox"/>
	G	F	E	D	C	B	A	A ⁺	A ⁺⁺	A ⁺⁺⁺
<input type="checkbox"/> M	< 27 %	≥ 27 %	≥ 30 %	≥ 33 %	≥ 36 %	≥ 39 %	≥ 65 %	≥ 100 %	≥ 130 %	≥ 163 %
<input type="checkbox"/> L	< 27 %	≥ 27 %	≥ 30 %	≥ 34 %	≥ 37 %	≥ 50 %	≥ 75 %	≥ 115 %	≥ 150 %	≥ 188 %
<input type="checkbox"/> XL	< 27 %	≥ 27 %	≥ 30 %	≥ 35 %	≥ 38 %	≥ 55 %	≥ 80 %	≥ 123 %	≥ 160 %	≥ 200 %
<input type="checkbox"/> XXL	< 28 %	≥ 28 %	≥ 32 %	≥ 36 %	≥ 40 %	≥ 60 %	≥ 85 %	≥ 131 %	≥ 170 %	≥ 213 %

Water heating energy efficiency class in colder and hotter climate conditions

Colder: - 0.2 x = %

Hotter: + 0.4 x = %

The energy efficiency of the set of products indicated in this sheet may not reflect the actual energy efficiency after installation since such efficiency is affected by additional factors, such as the heat loss in the distribution system and the size of the products compared to the size and features of the building.

INSTALLER

USER

MAINTENANCE TECHNICIAN

TECHNICAL DATA







Immergas S.p.A.

42041 Brescello (RE) - Italy

Tel. 0522.689011

immergas.com



IMMERGAS

IMMERGASPA-ITALY
CERTIFIED COMPANY
UNI EN ISO 9001:2015

Design, manufacture and post-sale
assistance of gas boilers, gas water heaters
and related accessories



This instruction booklet is made of
ecological paper.

